



Environment Building Science

Course Instructor:

Course code: ARCH1106

CEASER MIGISHA

- ❖ Ceaser Migisha: He is a graduate member of Uganda Society of Architect.
- ❖ He has a Master of Architecture, in the field of Sustainable Energy Efficient Cities, Wits University South Africa,
- ❖ Currently studying Master of Business Administration (online), Bhrati Vidyapeeth University Pune India. BSc.
- ❖ Building Design and Technology, UMU, Uganda,
- ❖ Training in Planning and Management of Sustainable Cities, Human Management Settlement Institute, New Delhi.
- ❖ Ceaser has holds a certificate in Prince 2 Foundation and practitioner course is ongoing.

You can contact me at [0774636363](tel:0774636363) or ceaser.migisha@iuea.ac.ug or migprodesign@gmail.com

SOLAR SHADING AND VENTILATION

DEFINITION OF TERMS

Ventilation is the movement of air within the building and between the buildings

- Ventilation is commonly used also for temperature control
- Ventilation can also be used to increase the room air velocity, and by that way increase the convective heat transfer and decrease the thermal stress in high temperatures.
- Natural ventilation in buildings can create a comfortable and healthy indoor environment, and can save energy used in the mechanical ventilation systems.

SOLAR SHADING AND VENTILATION

DEFINITION OF TERMS

Building ventilation is necessary for supporting life by maintaining acceptable levels of oxygen in the air to prevent Carbon dioxide rising to unacceptably high concentration and to remove odour, moisture and pollution produced internally.

Ventilation has also been considered to remove excess heat in hot climates

As Architects we need to care for the well being of building occupants

SOLAR SHADING AND VENTILATION

DEFINITION OF TERMS

Importance of Ventilation:

For Ventilation and removing internally produced pollution

Indoor pollutants:

- 1) Odour: Bioeffluent associated with occupants, cooking, bathroom activities and waste
- 2) Carbondioxide: due respiration which is directly proportional to metabolic rate
- 3) Smoke: cigarrets

SICK BUILDING SYNDROME (SBS)

- Ventilation occupies an important position in the building design process as building occupants expect good standards of indoor air quality and comfort.
- People have become more aware of the effect of the indoor environment on health as a result of media publicity surrounding building related sickness (BRS) and the sick building syndrome (SBS).
- **SBS is fundamentally a complaint about the indoor air quality of a building which appears to be more common in air-conditioned buildings than in naturally ventilated buildings**
- Building related sickness comprises the sensation of stuffy, stale and unacceptable indoor air, irritation of mucous membranes, headache, lethargy and so forth. These problems have been intensified in the last three decades as a result of a global reduction in air infiltration to buildings and fluctuation in the recommended supply rate of outdoor air to buildings in order to conserve energy.

SOLAR SHADING AND VENTILATION

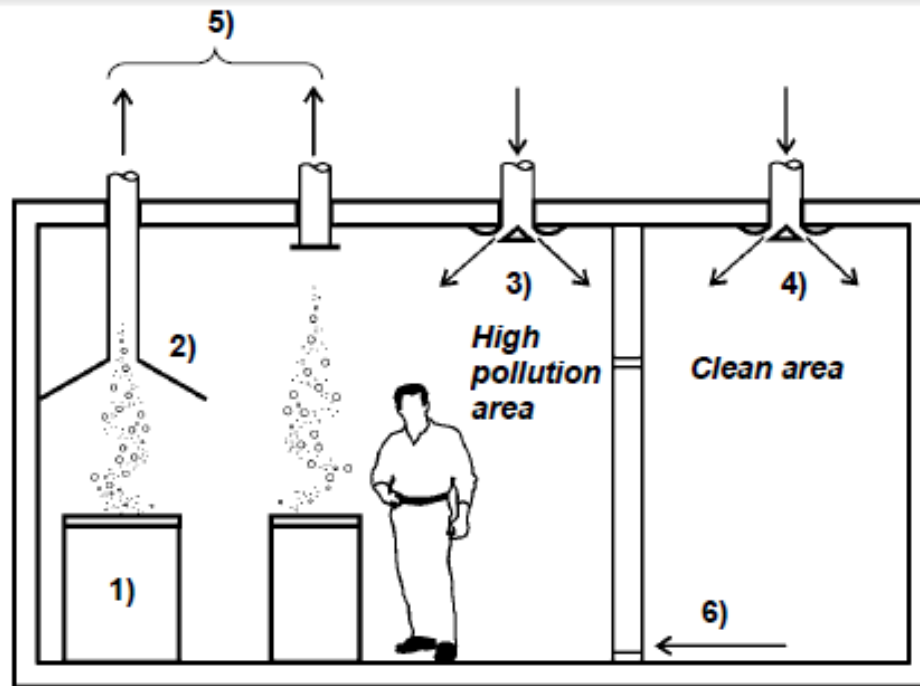

- 1) pollution generation processes are equipped with local exhaust;
- 2) exhaust air grilles and openings are located above the warm pollution generation sources;
- 3) air is supplied in the occupied zone in the rooms with high pollution generation to reduce exposure of the occupants to pollutants;
- 4) clean air is supplied to rooms with no specific pollution generation;
- 5) total exhaust airflow is larger than the supply air in the rooms with high pollution generation;
- 6) air is transferred from cleaner areas to more polluted areas through the openings in walls or doors

Figure 1. Air quality control principles for mechanical ventilation, (Vent Dis Course 2007).

5. Ventilation Efficiency (ϵ_v)

Methods for ventilating rooms are primarily divided into two different approaches; these are mixing (dilution) ventilation and displacement ventilation. In the case of mixing ventilation the air is supplied

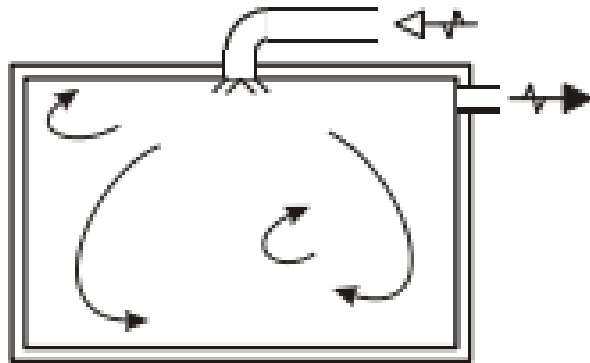

(a) *Mixing flow pattern*

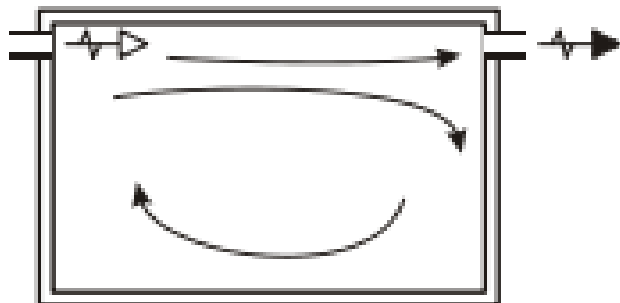

(b) *Short-circuiting flow pattern*

- 
- (a) illustrates complete mixing with a uniform concentration of contaminants in the room.*
- (b) illustrates a partly short-circuiting flow pattern where part of the supply air flows directly to the exhaust opening and the concentration of contaminants generated in the room is higher than the concentration in the exhaust duct – this should be avoided.*

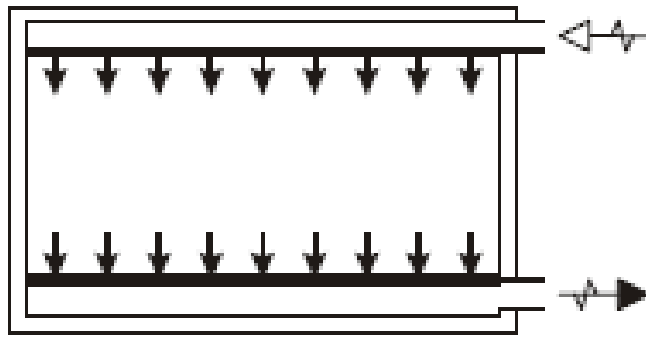

Figure 3. Laminar piston flow. This is used in special cases such as operating theatres and other super-clean rooms.

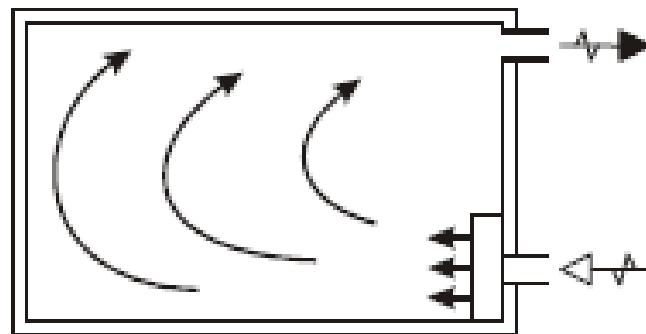

Figure 4. Displacement flow pattern. This creates two zones in a room – a lower and cleaner zone and an upper zone with a higher concentration of pollutants.

VENTILATION

Table 1. Values of ventilation effectiveness for various flow patterns.

<i>Flow pattern</i>	<i>Air change efficiency</i>	<i>Ventilation effectiveness, ϵ_v, as in Equation 1</i>
Complete mixing	50 %	1
Piston flow	100 %	2
Displacement flow	50-100%	1-2
Short circuiting flow	< 50%	0-1

Table 7. Summary of ventilation strategies for better indoor air quality and energy efficiency.

<i>Strategy or technology</i>	<i>Effect on investment cost</i>	<i>Effect on indoor air quality</i>	<i>Effects on energy and operation</i>
<i>Win-win strategies that at the same time improve indoor air quality and reduce energy use</i>			
Use low emission building products	No extra cost	Improved	Up to 50 % reduction in ventilation rates
Ban smoking indoors	No extra cost	Improved	Up to 50 % reduction in ventilation rates
Use high efficiency air distribution in rooms	No extra cost	Improved	Up to 50 % reduction in ventilation rates
Use free cooling	No extra cost	Improved	Minor increase in fan energy – no effect in naturally ventilated buildings
Particulate filtration of intake air	Minor extra cost	Significant improvement	Minor increase due to pressure drop in the filter
Balancing of air flows	Small cost due to balancing work	Improved in rooms with too low ventilation	May decrease or increase slightly
Keep air handling system clean with better maintenance	No extra cost	Improved supply air quality	Reduced energy use due to lower pressure drop

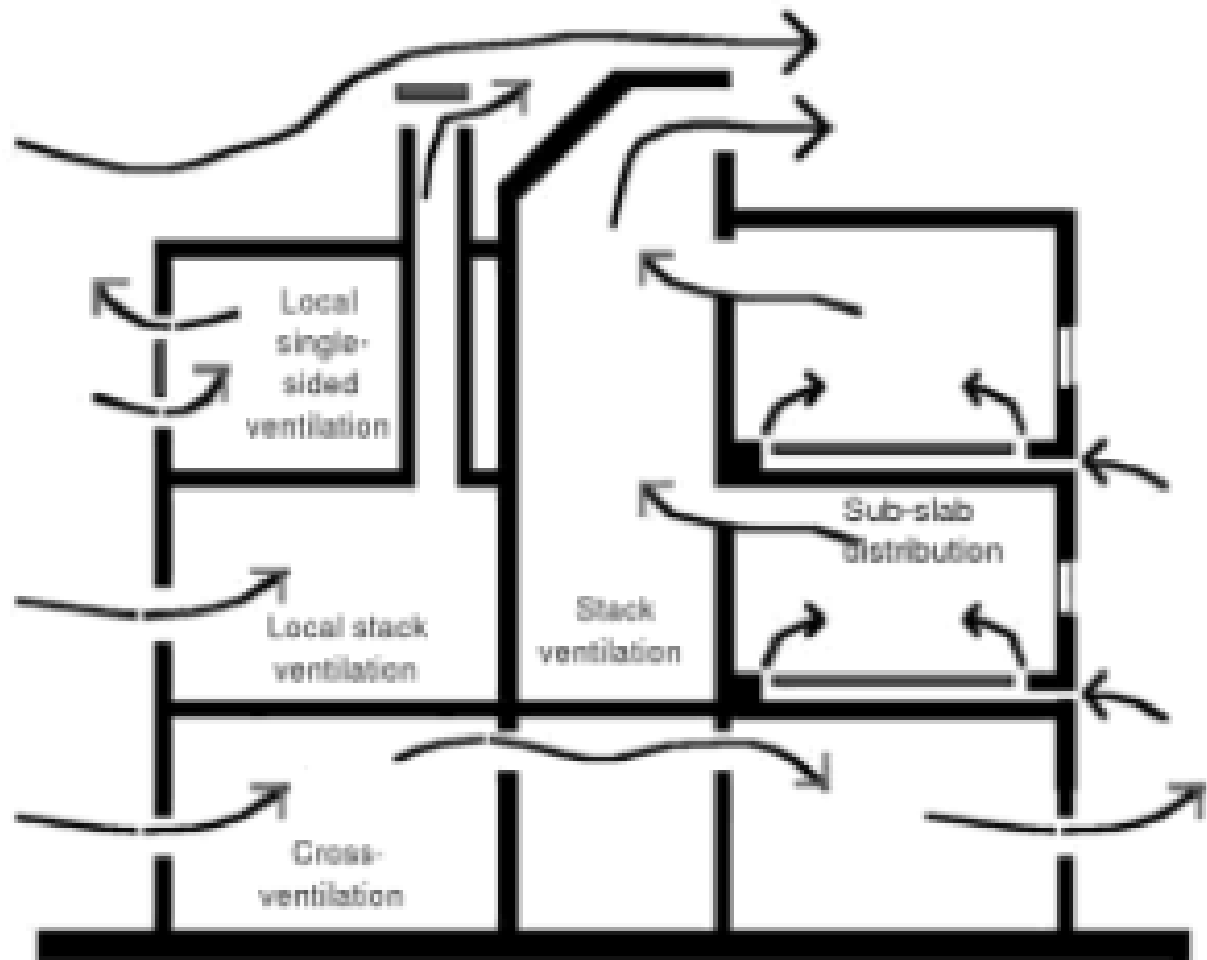

Source: Axley (2001)

Figure 1.9 *Mixed natural ventilation strategies in a single building to satisfy local and global ventilation needs*

- 
- Natural ventilation in the urban environment should take into account of lower wind velocity, as well as noise and pollution
 - Ventilation systems can not rely upon low level inlets since the outdoor air at street levels may be contaminated and yet the inlets may be shielded from wind

NATURAL VENTILATION STRATEGIES: URBAN ENVIRONMENT

- Wind variation-induced single sided ventilation
- Wind driven Cross Ventilation
- Buoyancy Driven stack Ventilation

Wind variation-induced single sided ventilation

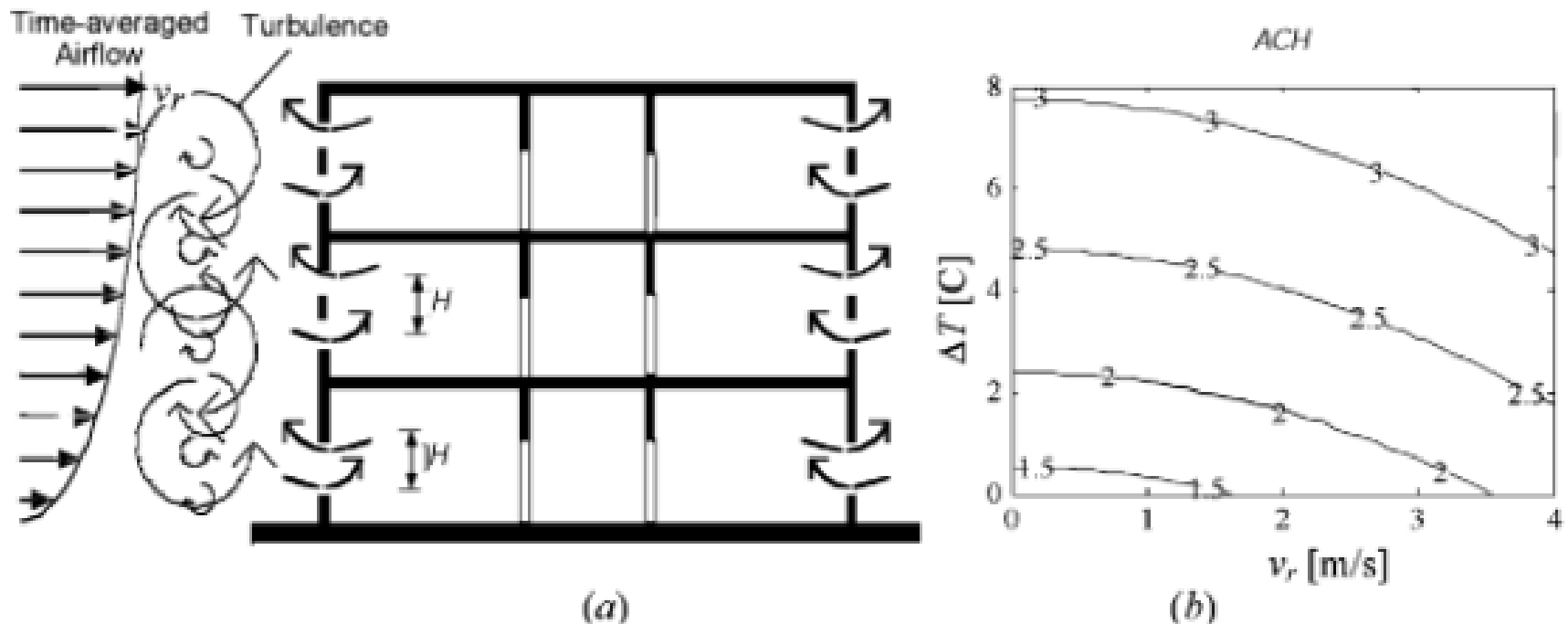

Source: Axley (2001) (a); Cristian Ghiaus (b)

Figure 1.5 (a) Single-sided wind-driven ventilation; (b) air changes per hour calculated for a room of 2.7m in height with windows of 1.5m in height and a window area of one twentieth the floor area

Wind driven cross ventilation

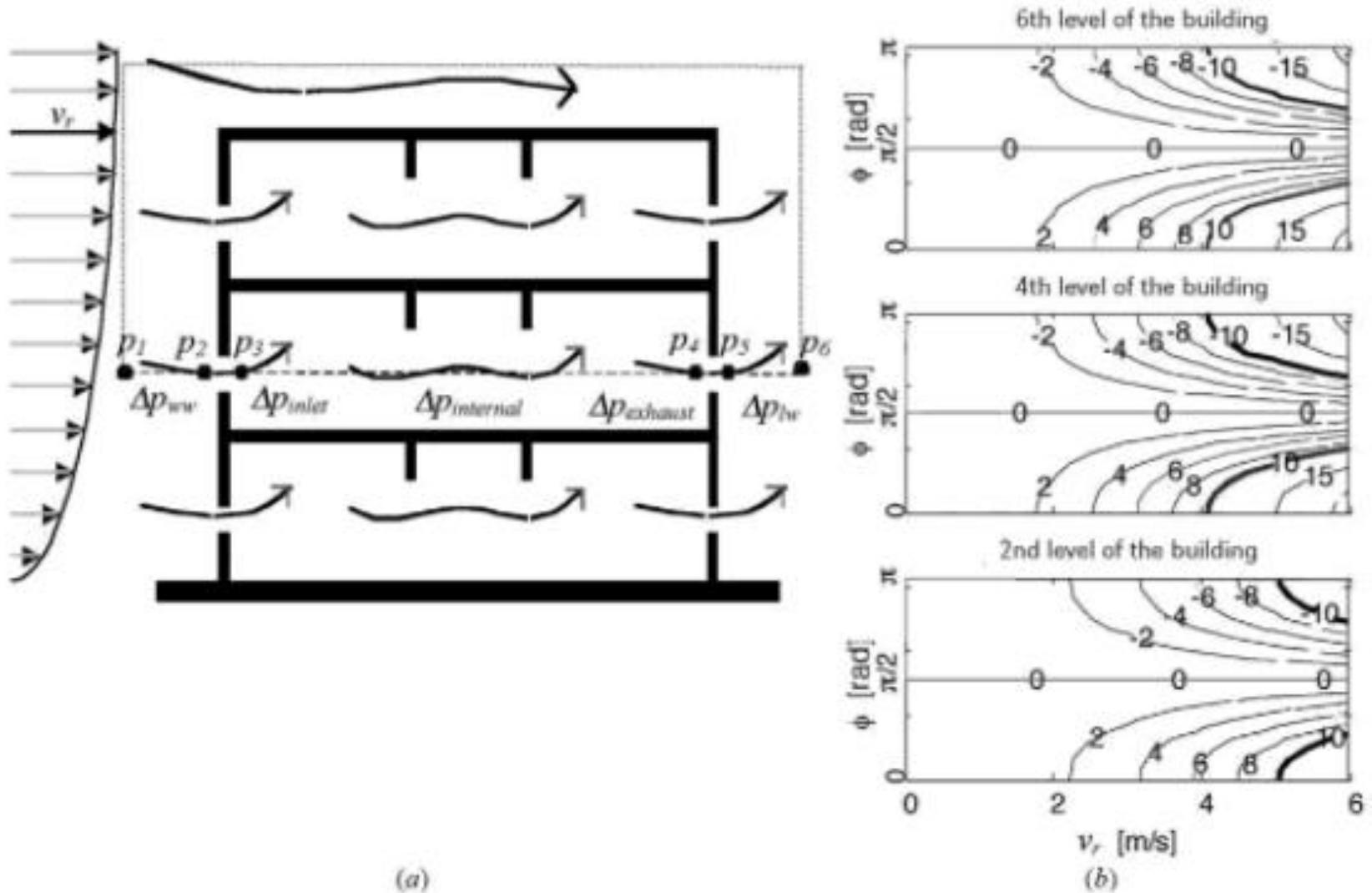

Source: Axley (2001) (a); Cristian Ghiaus (b)

Figure 1.6 Wind-driven cross-ventilation: (a) pressure drops associated with wind-driven cross-ventilation; (b) wind pressure differences for a rectangular, isolated building

Wind driven cross ventilation

- Wind airflow over a building tends to induce positive inward acting pressures on the windward surfaces and negative (outward pressures) on the leeward surfaces.
- **The two sided or cross ventilation takes place air enters the building on one side, sweeps the indoor space and leaves the building on another side**

Buoyancy Driven Stack Ventilation

VENTILATION

- Warm air within a building will tend to move up and flow out of the upper level exhausts, while the cooler outdoor air will tend to flow in through lower inlets to replace it

Buoyancy Driven Stack Ventilation

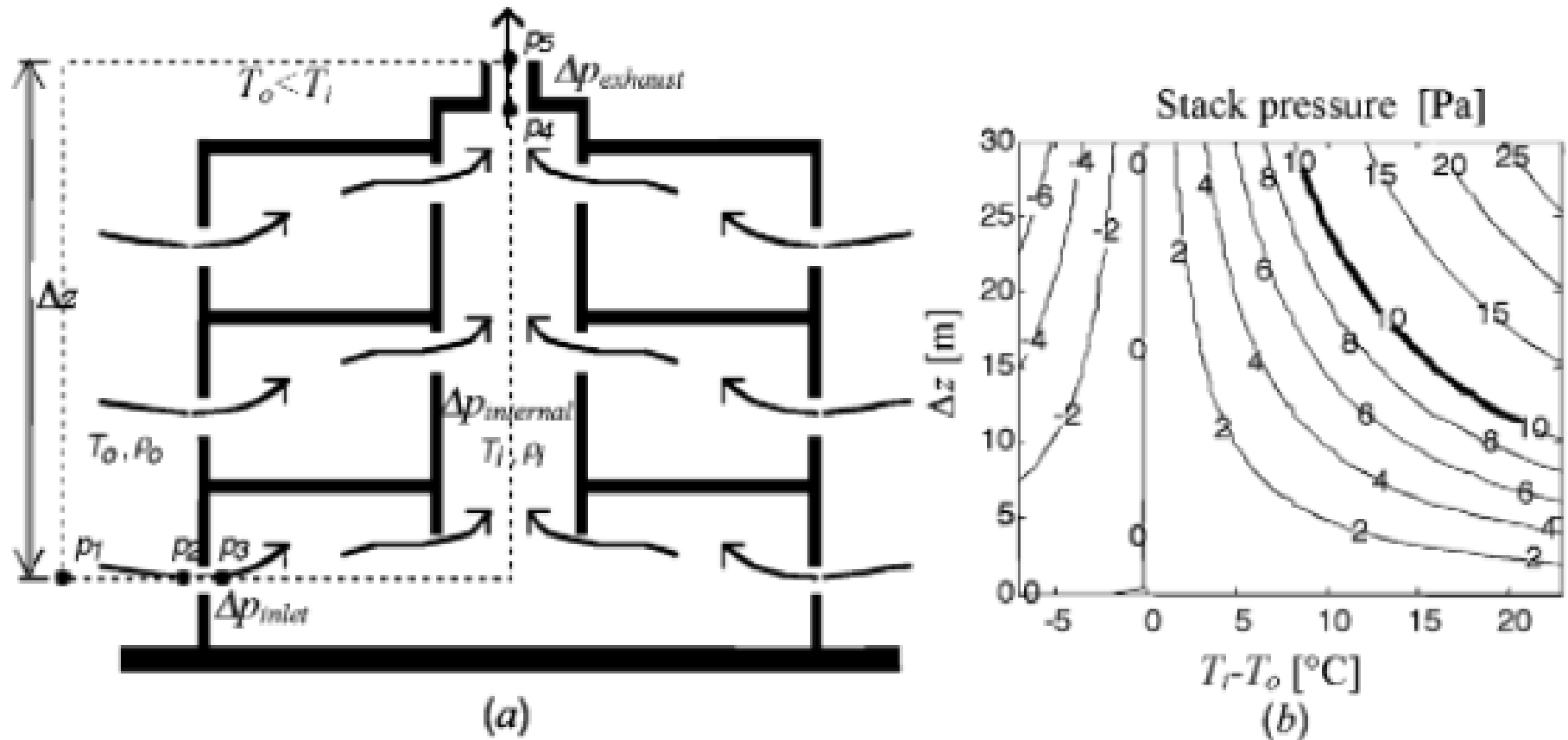

Source: Axley (2001) (a); Cristian Ghiaus (b)

Figure 1.7 Stack-pressure-driven natural ventilation: (a) pressure drops associated with buoyancy-driven stack ventilation; (b) stack pressure variation as a function of temperature difference and building height

Combined wind and Buoyancy Driven Stack Ventilation

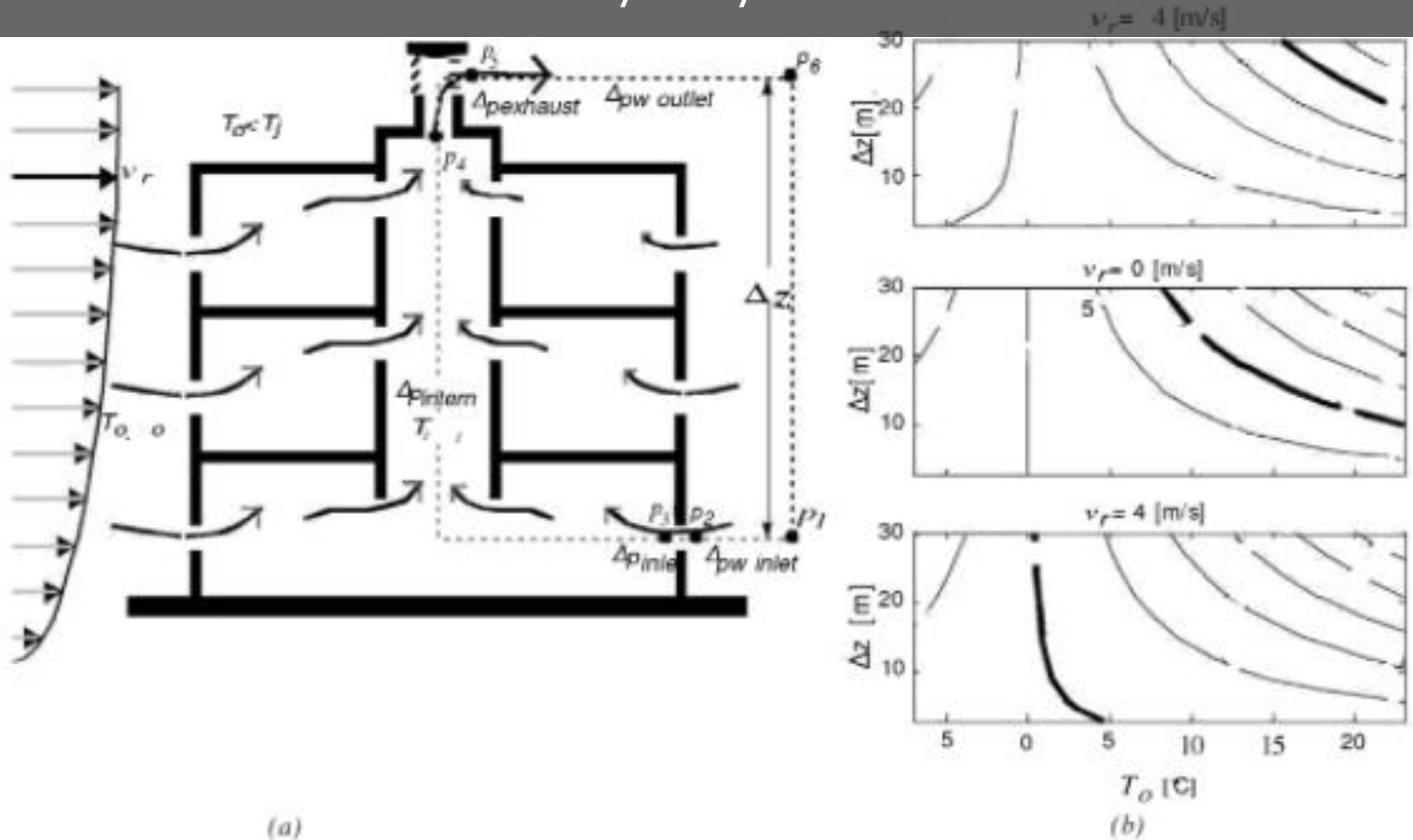

Source: Axley (2001) (a); Cristian Ghiaus (b)

Figure 1.8 Combined wind- and buoyancy-driven ventilation: (a) pressure drops; (b) total pressure as a function of wind velocity, temperature difference and building height

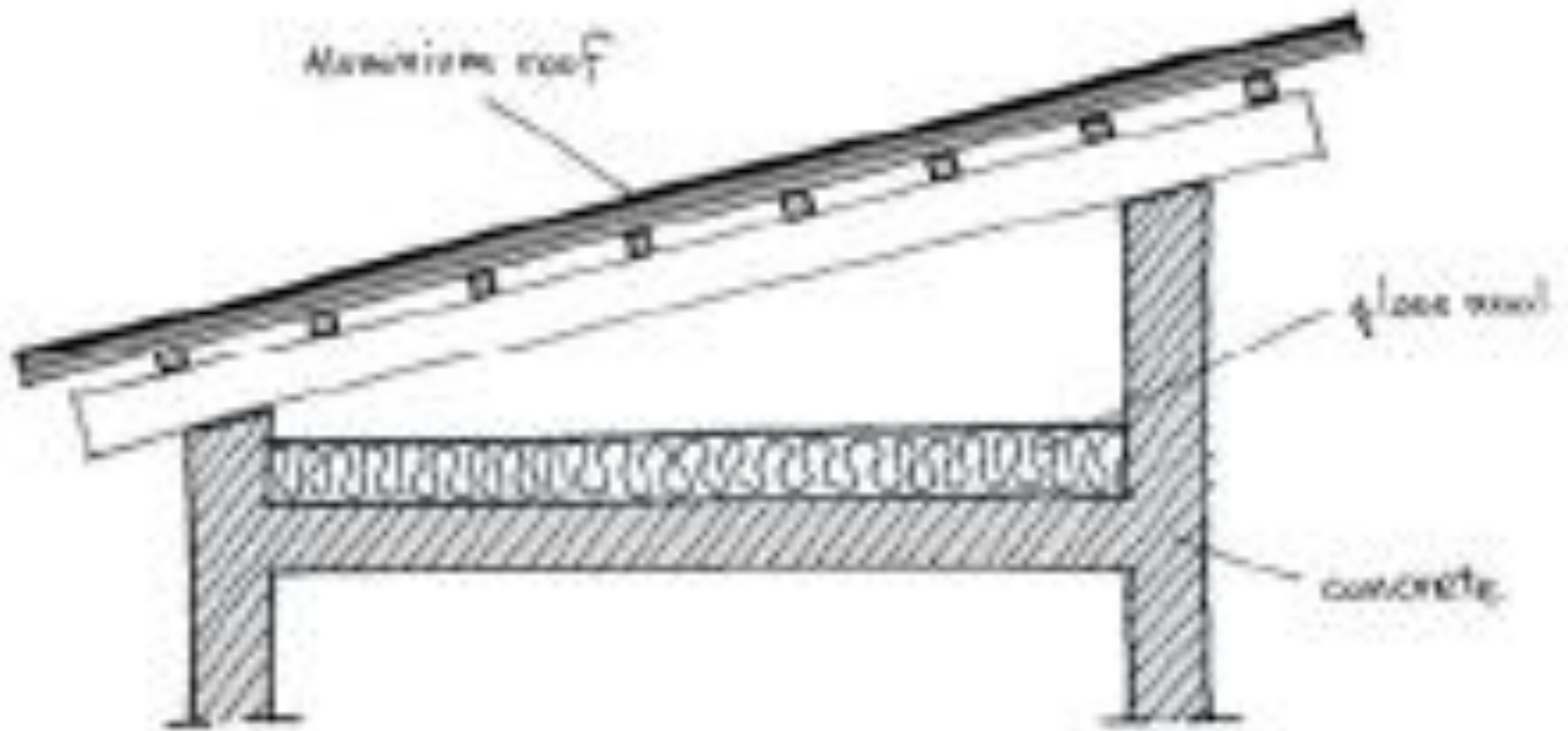

The roof in a tropical climate should be, as far as possible, reflective, insulated and ventilated. |

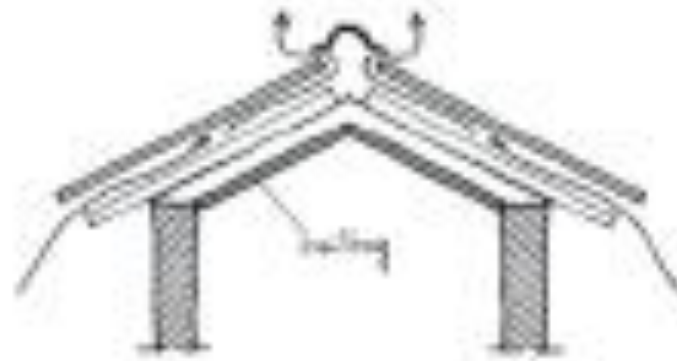
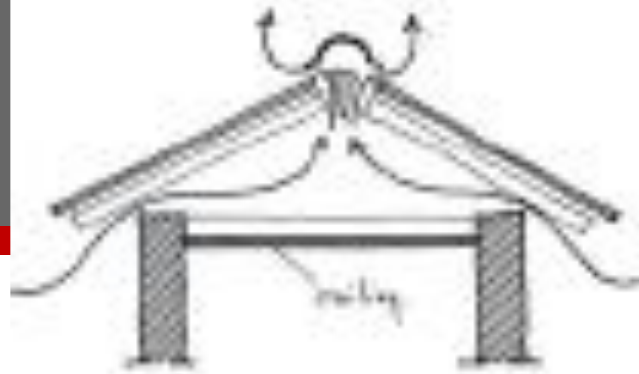

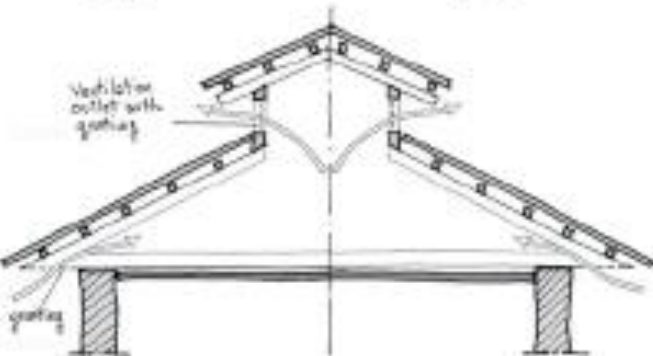
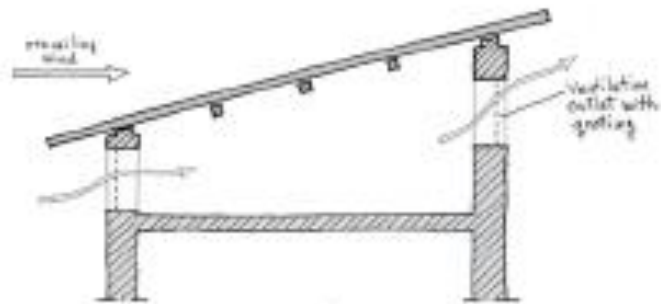
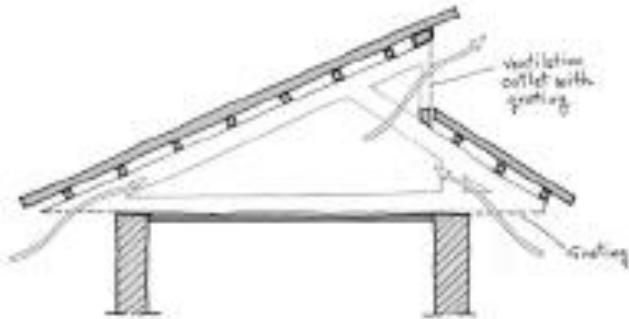
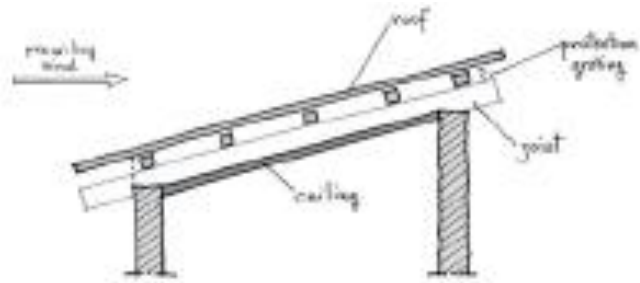



VENTILATION

Natural ventilation is possible due to the fact that warm air is lighter than cold air and therefore will tend to rise in relation to cold air.

Desirable design features to Allow Natural Ventilation

- Plan form should be shallow to allow for the possibility of cross-ventilation.
- Openings on oppo-site walls to allow cross-ventilation are better than on one or more adjacent walls.
- Building depth should not be more than about five times the floor to ceiling height if cross-ventilation is to be successful.
- For single sided ventilation, depth should be limited to about two and a half times the floor to ceiling height.
- Windows should be openable, but able to provide controlled air flow
- Atria and vertical towers can be incorporated into the design to allow the stack effect to draw air through the building, though care in meeting fire and smoke movement restrictions may determine the limits of what is possible

VENTILATION

- The effectiveness of natural ventilation and cooling can be improved by the use of low energy controlled lighting and low energy office equipment, thus reducing internal heat gain.



SOLAR SHADING

Decisions about roof shape, colour and composition, and the colour and composition of walls are crucial because they determine the overall performance of a building.

Design choices about the roofs in single storey buildings are especially critical, while the decisions about the walls are equally critical in both low and high rise buildings.

SOLAR SHADING: Roof design



Flat roof



Pitched roof



Double-pitched roof



Gabled roof



Vault



Dome

SOLAR SHADING: Roof design

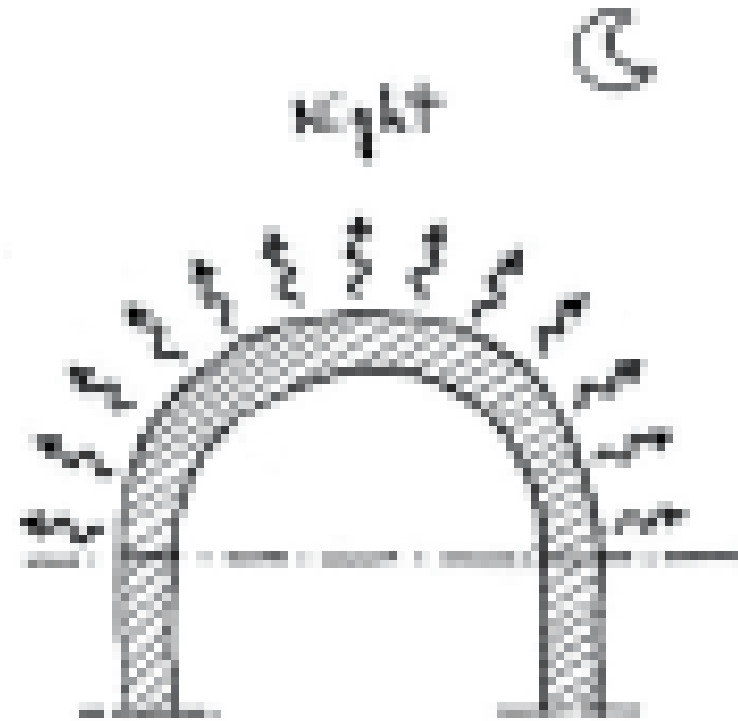
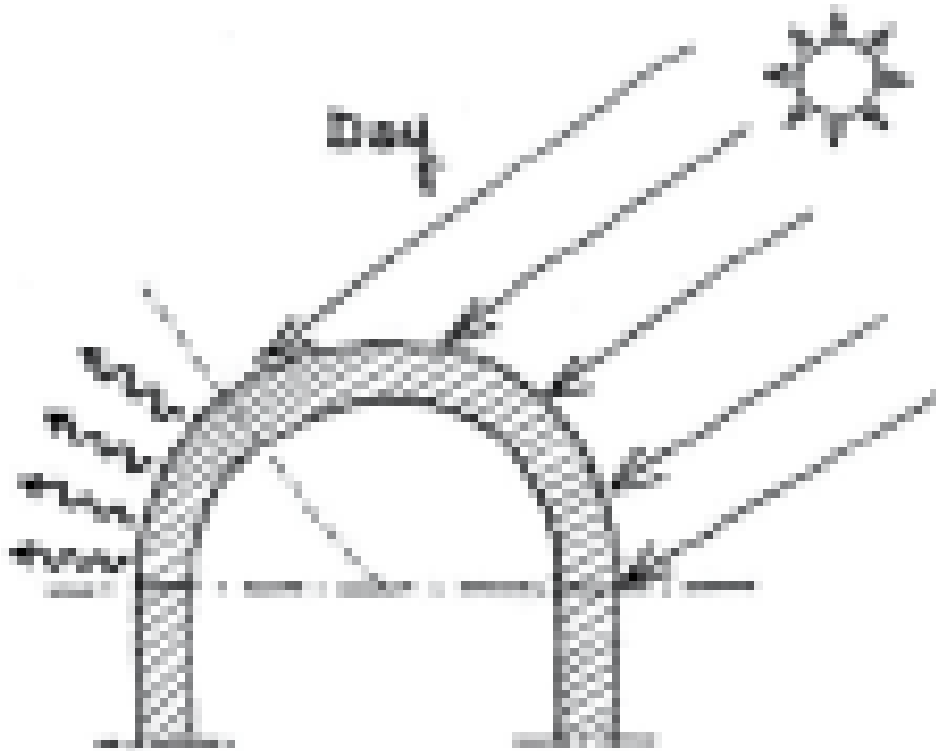

SOLAR SHADING: Roof design

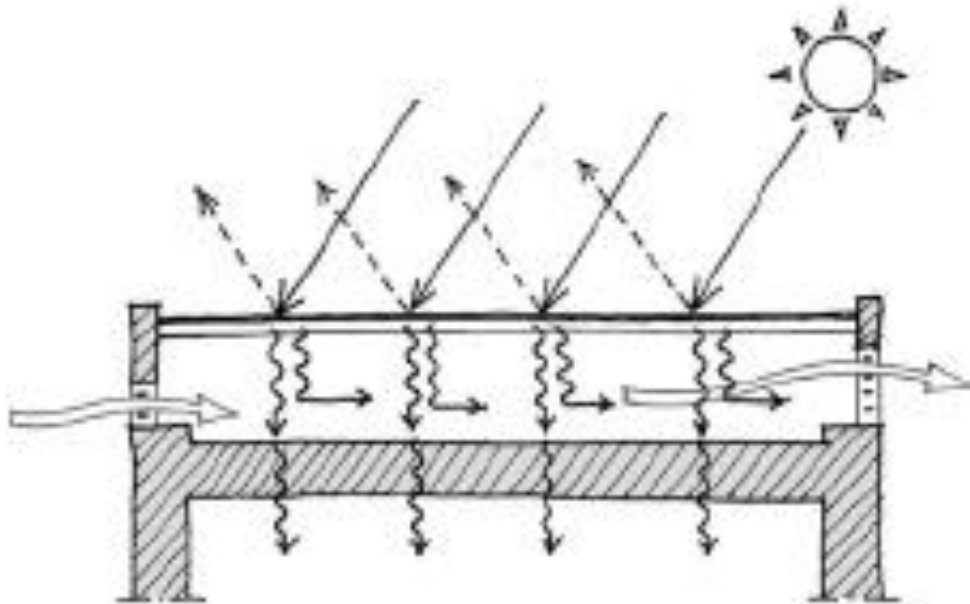
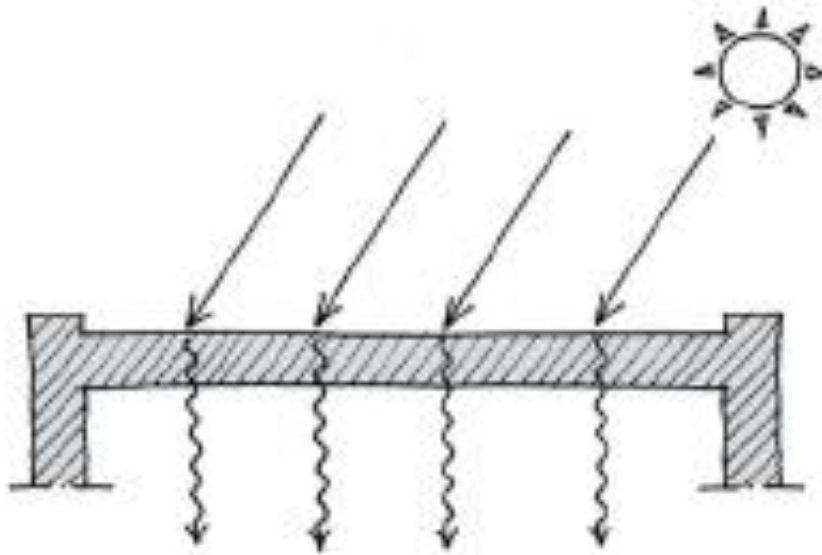

SOLAR SHADING

3.4.4.2 WALLS

Walls constitute the major part of the building envelope. A wall which is not protected from the sun heats up and transmits heat to the inside. The thickness and material of a wall can be varied to control heat gain. The resistance to heat flow through the exposed walls may be increased in the following ways:

- increase the thickness of the wall;
- adopt cavity wall construction;
- use walls made of suitable heat insulating material;
- fix heat insulating material on the inside or outside of the exposed wall;
- use radiant barriers;
- apply light coloured whitewash on the exposed side of the wall.

SOLAR SHADING: Lanscape

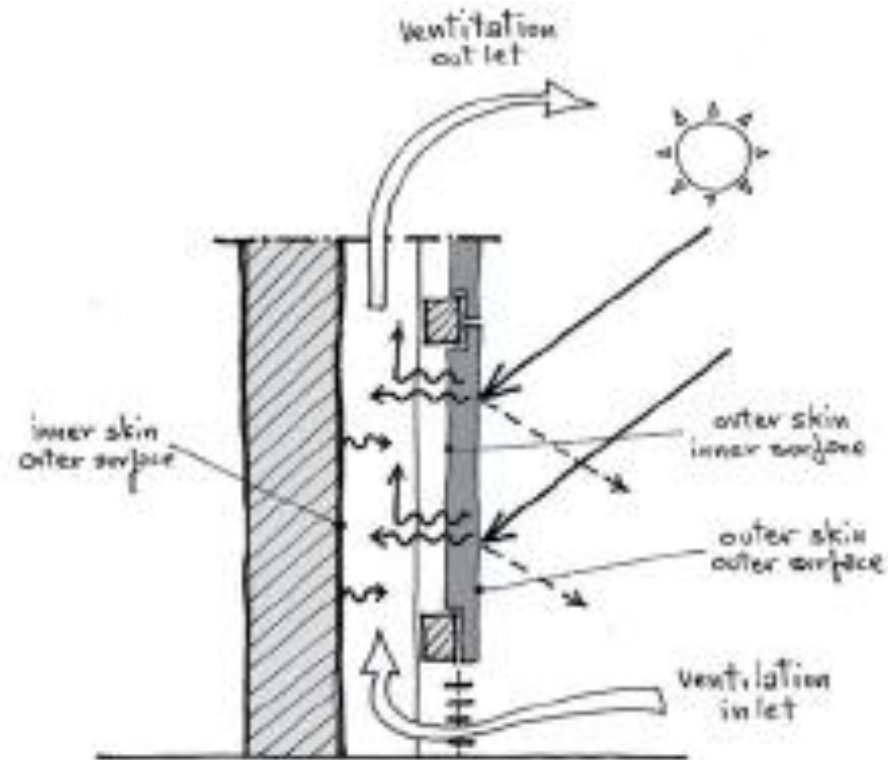
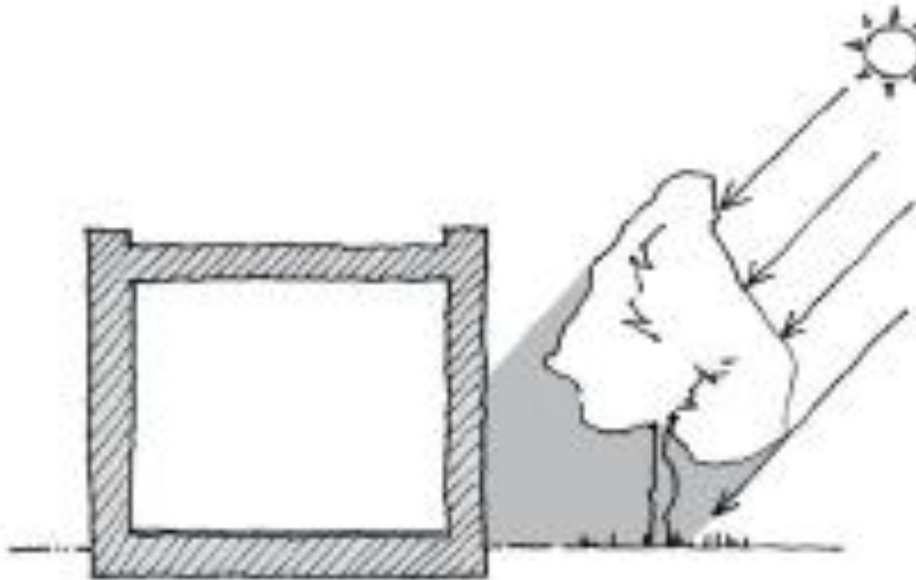
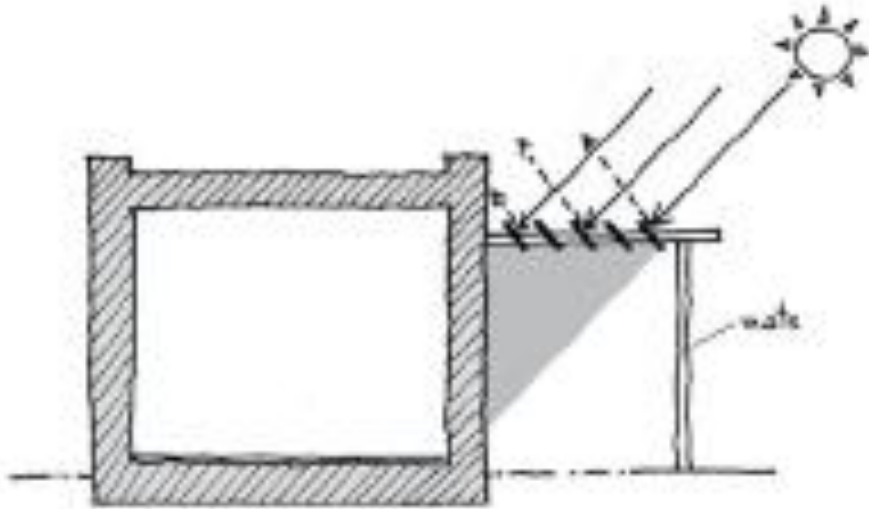

SOLAR SHADING: Window Design

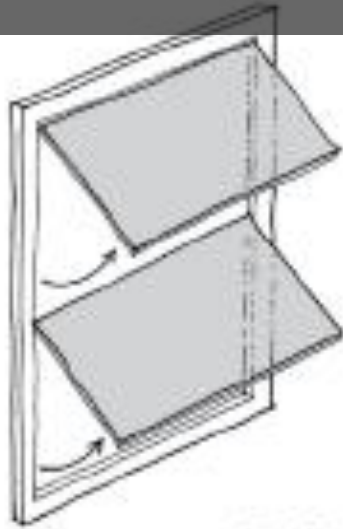

Awning [75%]



Casement [90%]

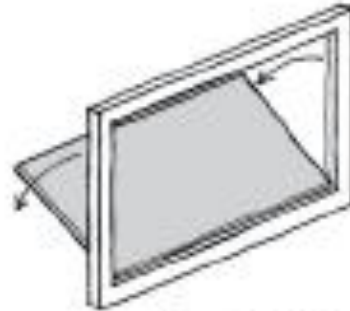

Hopper [45%]

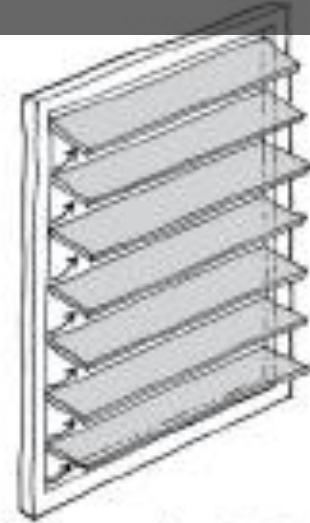

Jalousie [75%]

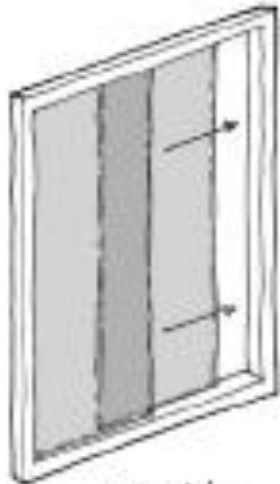

Horizontal sliding [45%]

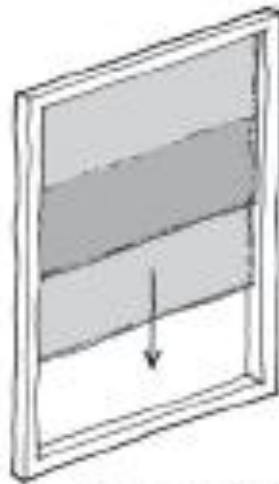



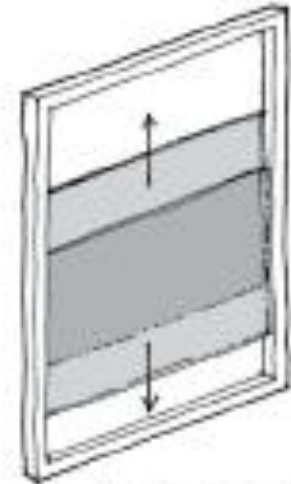

Single-hung [45%]





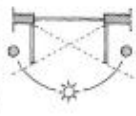
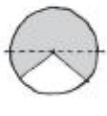

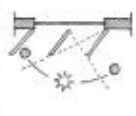

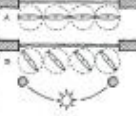
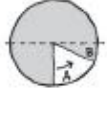
Double-hung [45%]

S

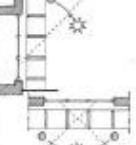
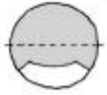
Vertical types

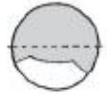

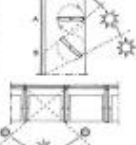



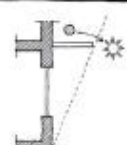
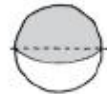

Shading device	plan view	Shading masks	Comments
			Vertical fins are most effective on the near-east, near-west exposures.
			Slanted vertical fins are most effective on east and west exposures.
			Rotating vertical fins are the most flexible and adjustable for daily and seasonal conditions. Most effective on east and west exposures.

Eggcrate Types

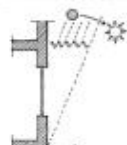
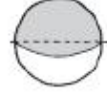
Shading device	Plan & side view	Shading masks	Comments
			Eggcrate types are combinations of horizontal and vertical types. Most effective in hot climates on east and west exposures.
			Eggcrate with slanted vertical fins (slant toward north). Most effective in hot climates on east and west exposures.
			Eggcrate with rotating horizontal louvers. Most effective in hot climates on east and west exposures.

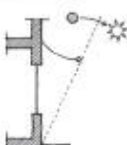
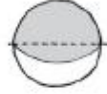
GA

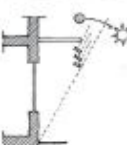
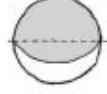
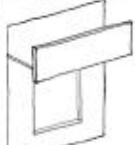
Horizontal types

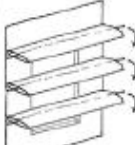
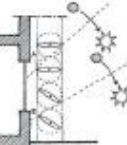
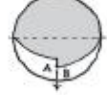
Shading device	Side view	Shading masks	Comments
			Straight overhangs are most effective on southern exposure.
			Louvers parallel to wall allow hot air to escape and are most effective on southern exposure.
			Awnings are fully adjustable for seasonal conditions and most effective on southern exposure.
			Horizontal louvers hung from solid overhangs cut out the lower rays of the sun. Effective on south, east and west exposures.
			Vertical strip parallel to wall cuts off the lower rays of the sun. Effective on south, east and west exposures.
			Rotating horizontal louvers are adjustable for daily and seasonal conditions. Effective on south, east and west exposures.

DN

Zero degrees latitude (equator)

cardinal

22.5° rotated

45° rotated

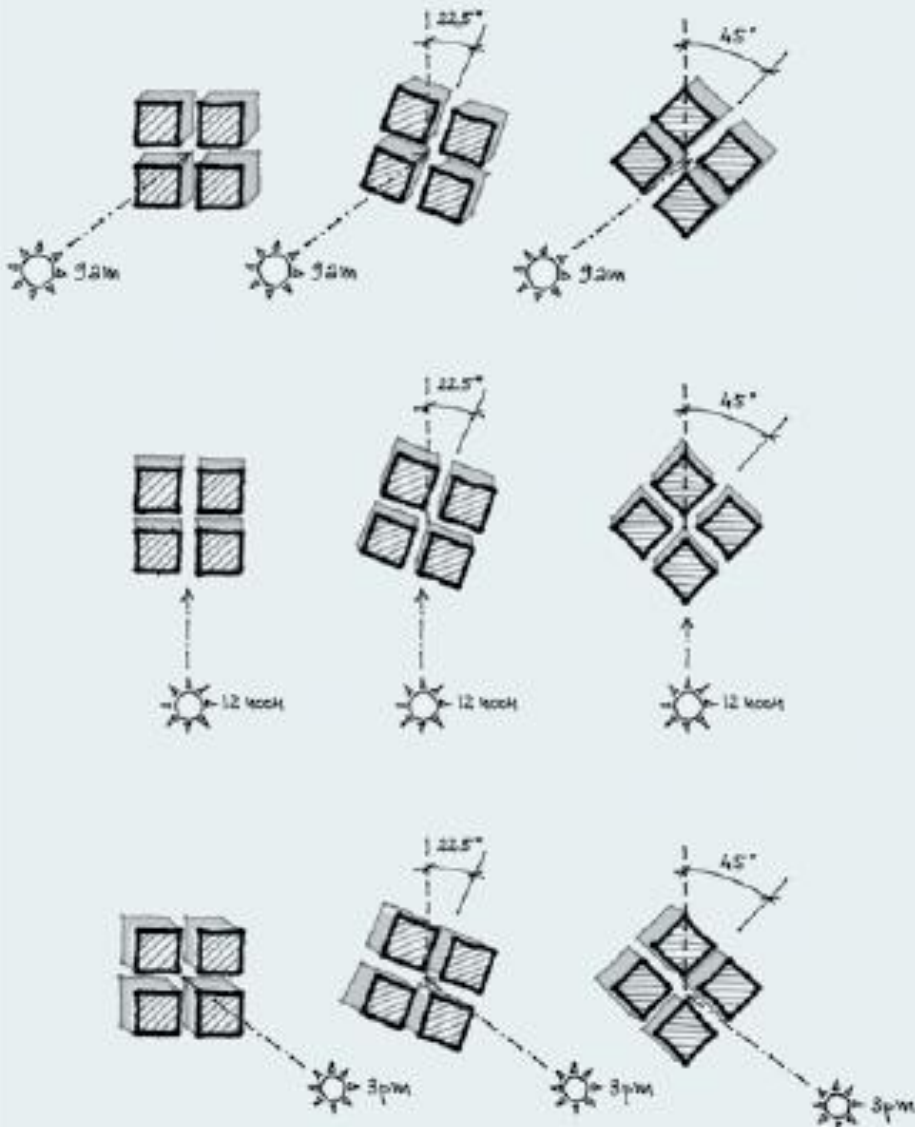

SOLAR SHADING

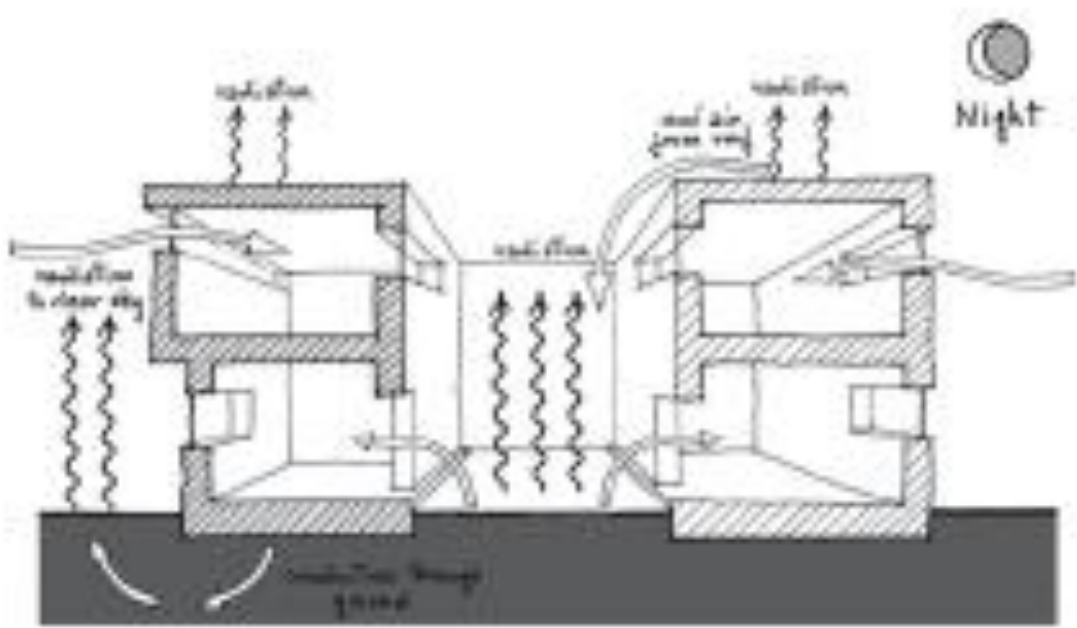
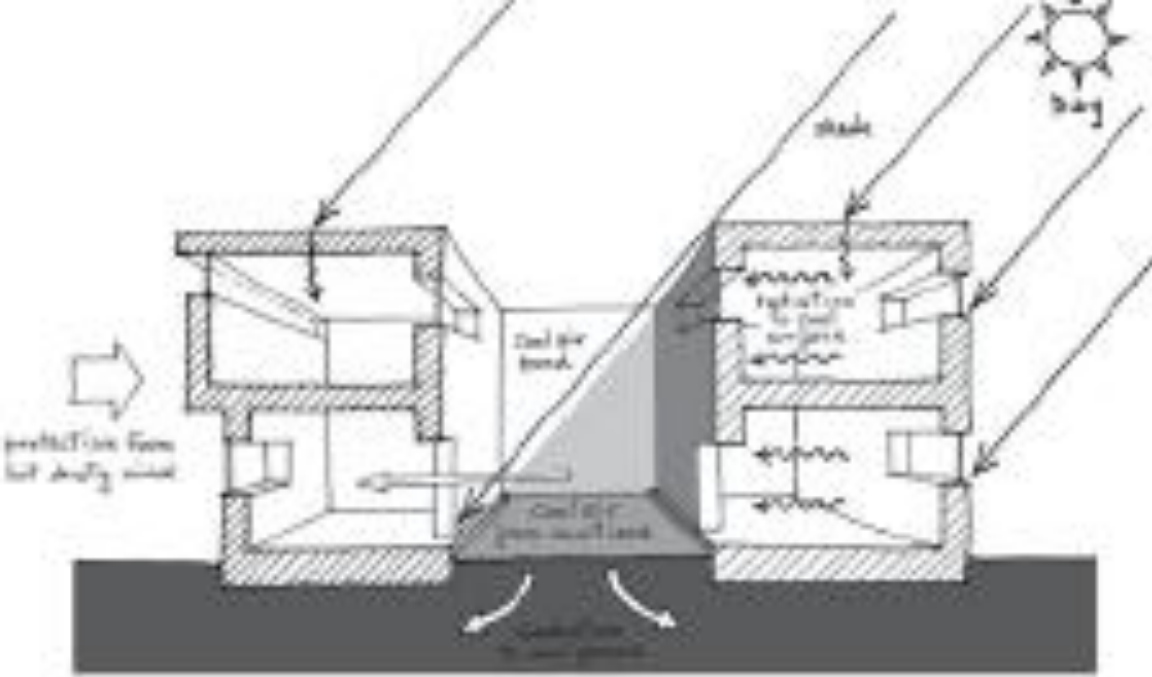



 **THANK YOU**