

PHYSICS
PAPER
TWO

P510/2

P510/2

PAST PAPERS WITH DIAGRAMS SINCE 1994 – 2012.

A LEVEL

2012.

SECTION A

1. (a) (i) State the laws of refraction of light (2mks)
(ii) State the conditions for total internal reflection to occur (02mks)
- (b) (i) Describe an experiment to determine the refractive index of a liquid using an air cell. (06mks)
(ii) Explain the default encountered in the experiment described in (b) (i) if white light is used (02mks)
- (c) A cube of glass of side 3cm and refractive index of 1.5 is placed on a thin film of liquid as show in figure 1

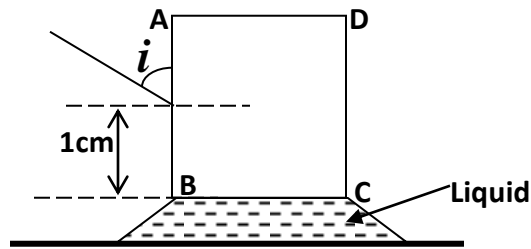

Fig. 1

A ray of light in a vertical plane strikes side AB of the glass cube at an angle $i = 45^\circ$ after refraction at X, the ray is reflected at critical angle of the glass-liquid interface.

- (i) Calculate the critical angle of glass-liquid interface. (03mks)
(ii) Find the position from B where the ray strikes the glass - liquid interface. (02mrk)
- (d) Explain why the rays from the sun can still be seen shortly after sunset (02mks)
2. (a) with the aid of a ray diagram, explain the following as applied to lenses
(i) Conjugate points. (02mks)
(ii) Spherical aberration (02mks)
- (b) An object, O, placed in-front of a converging lens forms a real image, I on the screen. The distance between the object and its real image is, d , while that of the image from the lens is x .
Derive the expression for the least possible distance between the object and its real image (05mks)
- (c) Give the properties of the lenses in an achromatic combination (03marks)
- (d) A compound microscope consists of two converging lenses of focal lengths 1.0cm and 5.0cm respectively. An object is placed 1.1cm from the objective and the microscope is adjusted so that the final image is formed 30cm from the eye piece. Calculate;
(i) the separation of the lenses. (03mks)

- (ii) the magnifying power of the lenses
- (e) State two differences between a compound microscope and an astronomical Telescope. (02mks)

SECTION B

3. (a) What is meant by the following terms as applied to sound?
- (i) Resonance (01mk)
 - (ii) Fundamental frequency (01mk)
- (b) Describe an experiment to determine the end-correction of a resonance-tube (05mks)
- (c) A wire of length 50cm, density 8.0gcm^{-3} is stretch between two points. If the wire is set to vibrate at the fundamental frequency of 15Hz, calculate
- (i) the velocity of the wave along the wire. (03mks)
 - (ii) the tension per unit area of the cross-section of the wire (03mks)
- (d) Explain using the principle of superposition of waves the formation of
- (i) Beats (04mks)
 - (ii) Stationary waves (03mks)
4. (a) (i) What is plane polarized light? (01mks)
- (ii) Why is it not possible to polarize sound waves? (01mks)
- (b) (i) Unpolarized light is incident on a sheet of Polaroid, A, as shown in figure

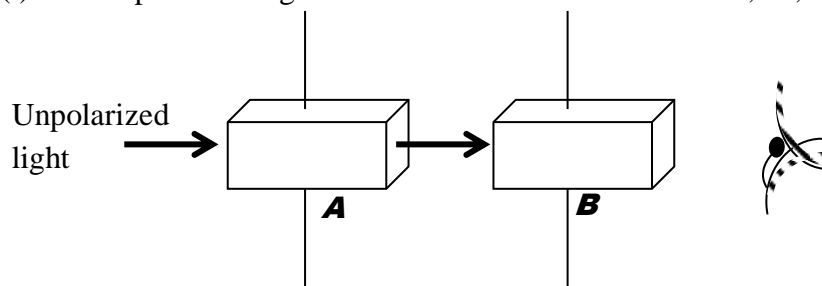

Explain what would be observed if a second Polaroid sheet B is rotated about an axis perpendicular to the direction of the incidence. (03mks)

- (ii) Sunlight is reflected off a glass window of refractive index 1.55. What should the elevation of the sun be if the reflected light is to be completely polarized? (03mks)
- (c) Given the diffraction grating and a spectrometer, describe how you would use them to measure the wavelength of light from a given source (07mks)
- (d) A parallel beam of monochromatic light of wave length 650nm is directed normally to a diffraction grating which has 600lines per mm.

Determine;

- (i) The number of diffraction images. (03mks)
- (ii) the angle of diffraction of the highest order diffraction image (03mks)

SECTION C

5. (a) Define the following.
- (i) Webber
 - (ii) Ampere
- (b) A circular coil of N turns, each of radius R carries a current I .
- (i) Write an expression for the magnetic flux density at the center of the coil.
 - (ii) Sketch the magnetic fields pattern associated with the coil.
- (c) Describe how a deflection magnetometer can be used to investigate the variation of magnetic flux density at the center of a circular coil with the current flowing through the coil.
- (d) Two parallel wires P and Q , each of length 0.2m carry currents of 10A and 1A respectively in opposite directions as shown in figure 3.

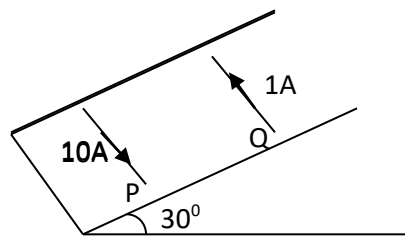

Fig.3

The distance between the wires is 0.04m . If both wires remain stationary and the angle of the plane with the horizontal is 30° , calculate the weight of Q .

- (e) (i) State why the damping in the ballistic galvanometer should be as small as possible.
- (ii) Describe how the damping can be reduced in practice.
6. (a) (i) Define the terms self-induction and mutual induction.
- (ii) State Faraday's law of electromagnetic induction.

- (b) (i) Describe the structure and action of an a.c transformer.
- (ii) Explain why the voltage at a generating power station must be stepped up to a very high value for long distance transmission.
- (c) In figure 4, a conducting rod PQ of length 20 mm rests on a smooth conducting frame to form a complete circuit of resistance 4.0Ω . When a force, F , is applied, the rod moves at a constant velocity of 6.0ms^{-1} perpendicular to a uniform magnetic field of flux density 1.5T.

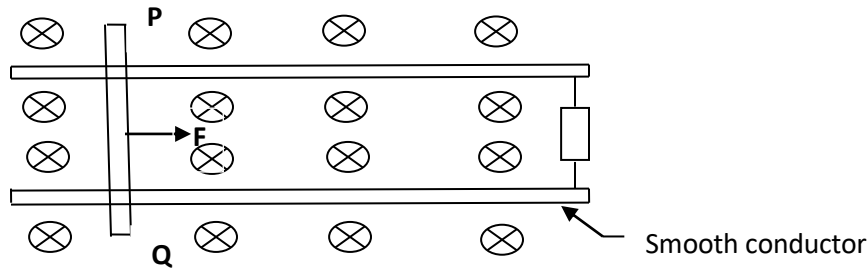

Fig.4

- (i) Explain why the rod PQ moves with constant velocity.
- (ii) Calculate the magnitude of the induced e.m.f.
- (iii) Calculate the magnitude of the Force, F .
7. (a) Define the tem peak value and root mean square value of an alternating current.
- (b) A coil of many turns of wire is connected in parallel with an electric bulb to a d.c supply as shown in figure 5.

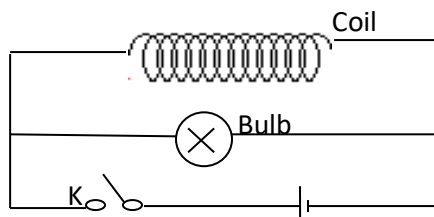

Fig.5

At the instant switch K is closed, the bulb flashes briefly for a short time and then goes off. Explain the observation.

- (c) A sinusoidal alternating voltage of 20V (rms) and frequency of Hz is applied across a coil of wire of Inductance 0.2H and negligible resistance.
- (i) Find the reactance of the coil at this frequency.
- (ii) Calculate the Rms value of the current which passes through the coil.
- (iii) Explain why on average the power delivered to the inductor in one cycle is zero.

- (d) Describe with the aid of a labeled diagram the structure and action of a hot wire ammeter.

SECTION D

8. (a) What is meant by **electromotive force of a cell**?
- (b) Describe an experiment to determine e.m.f and internal resistance of a cell using an ammeter, a resistance box and a voltmeter.
- (c) (i) Define **temperature coefficient of resistance**.
- (ii) Explain why the resistance of a thermistor reduces when current is passed through it.
- (d) (i) Derive the balance conditions for a Wheatstone bridge.
- (ii) Explain **one** reason other than faulty apparatus and poor electrical constant, why it may not be possible to obtain balance in Wheatstone bridge in an experiment to compare two resistances.
- (e) In an experiment to investigate the variation of resistance with temperature, a nickel wire and a 10Ω standard resistor were connected in the left – hand gap respectively of a meter bridge. When the nickel wire is at 0°C , a balance point is 50 cm from the same end of the bridge. Calculate the temperature of the nickel wire if the balanced length is 42cm.
9. (a) (i) What is meant by electric field intensity at a point?
- (ii) Describe how distribution of charge on a charged conductor of the shape shown in figure 6 can be investigated.

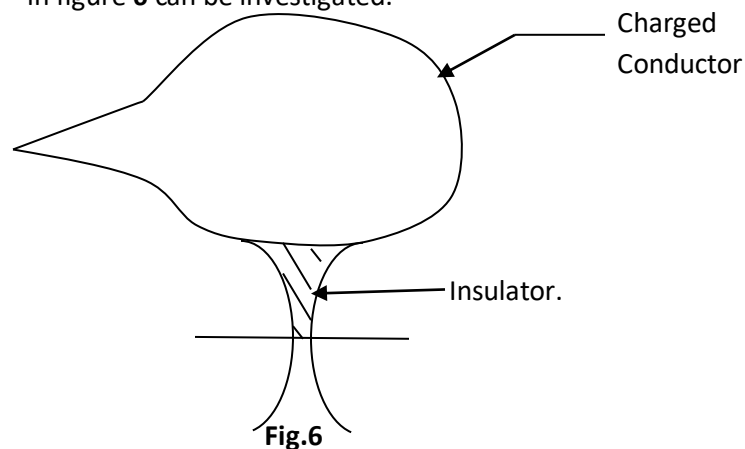

- (iii) Explain how a lightning conductor protects a house from lightning.
- (b) (i) What is an **electric field line**?
- (ii) Derive the expression for the electric potential at a point a distance, a , from an isolated charge of magnitude Q in air.

- (c) Figure 7 shows charges q_1, q_2 and q_3 of $+46.3\mu\text{C}$, $-34.7\mu\text{C}$ and $+23.4\mu\text{C}$ respectively, placed in a straight line in air.

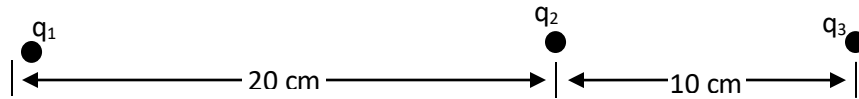

Figure 7

Find the force on q_3 .

10. (a) Define the following terms:
- The farad.
 - Relative permittivity.
- (b) You are provided with the following apparatus, a battery, two switches a capacitor of known resistance, a ballistic galvanometer and connecting wires.

Describe an experiment that can be carried out using the above apparatus to determine the unknown resistance of a capacitor.

- (c) The diagram in Figure 8 shows an arrangement of three capacitors C_1, C_2 and C_3 of capacitance $8\mu\text{F}$, $2\mu\text{F}$ and $6\mu\text{F}$ respectively.

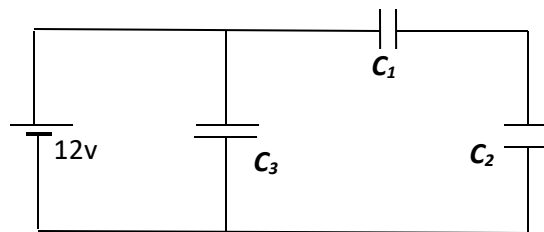

Fig. 3

Calculate the total energy stored:

- In all the capacitors when fully charged.
 - When the space between the plates of C_2 is filled with a dielectric of constant 1.25.
- (d) A capacitor of capacitance C is charged by a battery and then later isolated. When the plates of the capacitor are taken apart, deduce what happens to the potential difference between the plates.
- (e) Explain what happens if a conductor instead of a dielectric is placed between the plates of a charged capacitor.

2011.

SECTION A

1. (a) Define the following terms as applied to a concave lens:
- Principal focus,
 - Radii of curvature.
- (b) A point object is placed at a distance U in front of a diverging lens of focal length, f , to form an image at a distance V from the lens.
Derive an expression that relates U , V and f .
- (c) Describe an experiment to determine the focal length of a concave lens using a plane mirror, a converging lens and illuminated object.
- (d) What is meant by a:
- Visual angle?
 - Near point?
- (e) A person with a normal near point distance of 25cm wears spectacles with a diverging lens of Focal length 200cm in order to correct the far point distance to infinity. Calculate the near point distance when viewing using the spectacles
- (f) (i) Draw a ray diagram to show the formation of an image of a distance object in a terrestrial telescope.
(ii) State **two** disadvantages of the terrestrial telescope.
2. (a) What is meant by the term:
- Refraction
 - Absolute refractive Index.
- (b) Describe an experiment to determine the refractive index of a liquid using a travelling microscope.
- (c) Figure 1 shows monochromatic light X incident towards A on a Vertical screen.

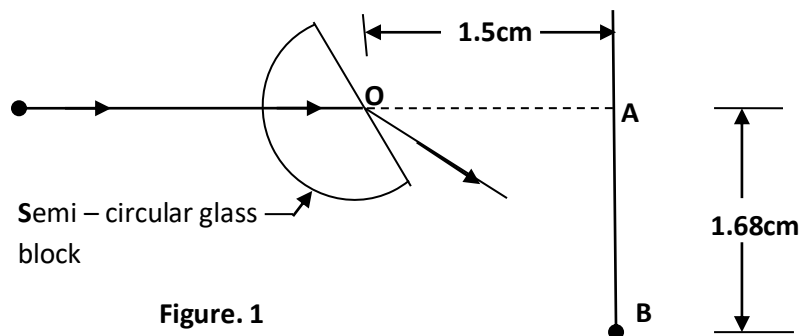

When the semicircular glass block is placed across the path of light with its flat face parallel to the screen, a bright spot is formed at A. When the glass block is rotated about a horizontal axis through O, the bright spot moves down from A towards B and then just disappears at B, a distance 1.68cm from A.

- i. Find the refractive index of the material of the glass block.
 - ii. Explain whether AB would be longer or shorter if a block of glass of higher refractive index was used.
- (d) (i) A ray of monochromatic light is incident at a small angle of incidence on a small – angle prism in air. Obtain the expression $d = (n - 1) A$, for the deviation, d of the light by the prism, where A is the refracting angle of the prism and n the refractive index.
- (ii) Calculate the minimum deviation produced by a 60° glass prism if the refractive index of the glass is 1.50.
- (iii) State any **two** applications of total internal reflection.

3. (a) (i) Define the terms **wave front** and **ray** in reference to a progressive wave.
- (ii) Draw a sketch diagram showing reflection of a circular wave by a plane reflector.

- (b) Figure 2 below shows a wave travelling in the positive x – direction away from the origin with a velocity of 9ms^{-1} .

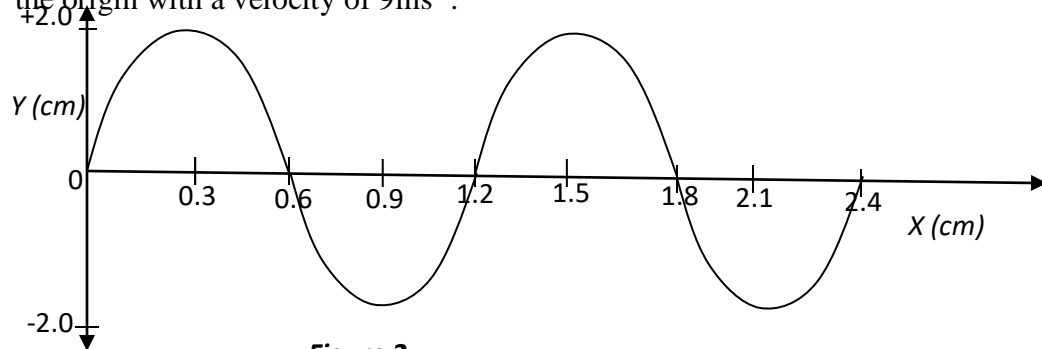

Figure 2

- (i) What is the period of the wave?
- (ii) Show that the displacement equation for the wave is

$$y = 2 \sin \frac{5}{3} \pi (9t - x).$$

- (c) What is meant by **Doppler Effect**?

- (d) **One** species of bats locates obstacles by emitting high frequency sound waves and detecting the reflected waves. A bat flying at a steady speed of 5 ms^{-1} emits sound of frequency 78.0 kHz and is reflected back to it.
- (i) **Derive** the equation for the frequency of the sound waves reaching the bat after reflection.
- (ii) Calculate the frequency of the sound received by the bat given that the speed of sound in air is 340 ms^{-1} .
- (e) (i) What is meant by intensity of a sound note?
- (ii) Distinguish between **Loudness** and **pitch** of a sound note.
4. (a) What is meant by the following terms:
- (i) Unpolarized light,
- (ii) Plane polarized light?
- (b) (i) Describe briefly how plane polarized light is produced by double refraction.
- (ii) Explain briefly **one** application of polarized light.
- (c) Explain:
- (i) how **two** coherent sources are obtained using a biprism.
- (ii) Why interference effects are not observed in thick films.
- (d) In Young's double slit experiment, the slits are separated by 0.28 mm and the screen is 4 m away. The distance between the fourth bright fringe and the central fringe is 12 cm . Determine the wavelength of the light used in the experiment.
- (e) Explain the effect of increasing the number of narrow slits in diffraction grating on the intensity of diffraction fringes.

SECTION B

5. (a) Define the following terms as applied to alternating Voltage.
- (i) Root – mean – square value,
- (ii) Peak Value.
- (b) (i) An alternating voltage is applied across a capacitor of capacitance, C . show that the current in the circuit leads the voltage by $\frac{\pi}{2}$.
- (ii) Find the expression for the capacitive reactance in terms of frequency, f and capacitance, C .

- (iii) A capacitor of $0.1\mu\text{F}$ is in series with an a.c. source of frequency 500Hz . If the r.m.s value of the current flowing is 6mA , calculate the voltage across the capacitor.
- (c) A bulb is connected in series with an inductive coil and a d.c source as shown in Figure 3.

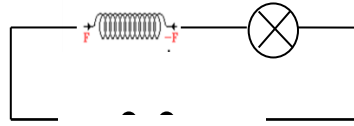

Figure 3

- (i) What happens to the brightness of the bulb when an iron core is inserted in the coil?
- (ii) Explain what happens to the brightness of the bulb when the d.c. source is replaced with an iron core inserted in the coil.
- (d) (i) What is **hysteresis loss**?
- (ii) How can hysteresis loss be minimized in the a.c transformer?
- (iii) Explain why the primary current in the a.c transformer increases when the secondary coil is connected to the load.
6. (a) (i) Draw a well labeled diagram to show the structure of the repulsion type moving iron ammeter.
- (ii) Explain how the ammeter in (a)(i) above is able to measure alternating current.
- (b) (i) Write down an expression for the magnetic flux density at the center of a flat circular coil of N , turns of each radius, a , carrying current I .
- (ii) Describe how you would determine the value of the earth's magnetic flux density at a place, using a search coil.
- (c) A coil of 50 turns and radius 4cm is placed with its plane in the earth's magnetic meridian. A compass needle is placed at the center of the coil. When a current of 0.1A passes through the coil, the compass needle deflects through 40° . When the current is reversed, the needle deflects through 43° in the opposite direction.
- (i) Calculate the Horizontal component of the earth's flux density.

(ii) Calculate the magnetic flux density of the earth at that place given that the angle of dip at the place is 15° .

- 7 (a) State the laws of electromagnetic induction.
- (b) (i) A circular metal disc of radius, r , rotates in an anticlockwise direction at an angular velocity, ω , in a uniform magnetic field of flux density, B directed into paper as shown in **Figure 4**.

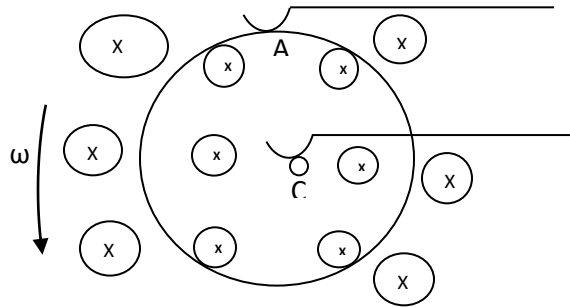

Figure 4.

A and C are contact points.

Derive an expression for the e.m.f induced between A and C.

- (ii) A copper disc of radius 10cm is placed in a uniform magnetic field of flux density, 0.02T, with its plane perpendicular to the field. If the disc is rotated parallel to the field about an axis through its center at $3000 \text{ revs min}^{-1}$, calculate the e.m.f. that is generated between its rim and the center.
- (c) Describe an experiment to demonstrate mutual induction.
- (d) The diagram in Figure 5 shows the arrangement by which a laboratory balance is critically damped. The aluminum beam supporting the pan moves in the magnetic field of two powerful magnets.

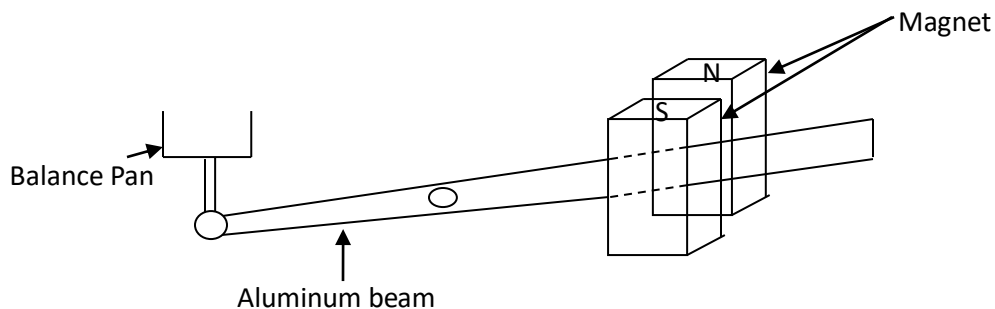

Figure 5.

- (i) Explain how damping is caused.

- (ii) What change would occur in the performance of the balance if the magnets were replaced by weaker ones?
- (e) (i) Define the **ampere**.
- (ii) Two parallel wires, P and Q of equal length 0.1cm, each carrying a current of 10A are a distance 0.05m apart, with P directly above Q. If P remains stationary find the weight of P.

SECTION C

8. (a) (i) Define electromotive force of a battery.
- (ii) A cell of e.m.f, E and internal resistance, r , drives current through a resistor of resistance, R , connected in series with it. Derive an expression for the efficiency of the circuit.
- (b) Describe with the aid of a diagram how you would standardize a slide wire potentiometer.
- (c) In Figure 6, AB is a uniform resistance wire of length 1m and resistance 4Ω . X is a driver cell of e.m.f 3V and internal resistance 1Ω and E_s is a standard cell. R_s is a standard resistor of resistance 10Ω which is connected in series with cell Y of e.m.f 1.2V and internal resistance 0.5Ω .

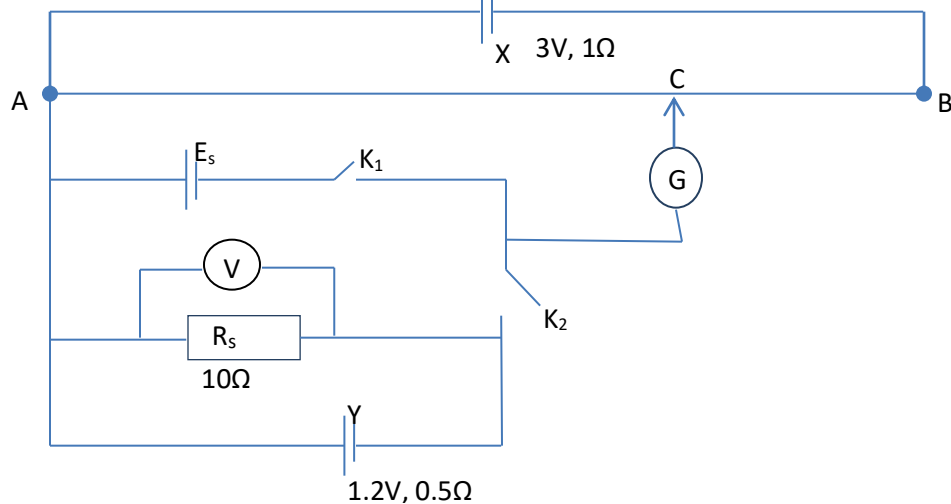

Figure 6

With switch K_1 closed and K_2 open, the balance length, AC is 60cm while the voltmeter reading is 1.14V. With switch K_1 open and K_2 closed, the balance length is 80cm. Calculate the:

- (i) $E.m.f$ E_s of the standard cell,

- (ii) Percentage error in the voltmeter reading.
- (d) Describe with the aid of a circuit diagram how you would measure the temperature coefficient of resistance of a material in form of a wire.
9. (a) State **Coulomb's law** of electrostatics.
- (b) Derive the relation between electric field intensity, E, and electric potential, V, due to a charge at a point.
- (c) Two pith balls P and Q each of mass 0.1g are separately suspended from the same point by threads 30cm long. When the balls are given equal charges, they repel each other and come to rest 18cm apart. Calculate the magnitude of charge on each ball.
- (d) Describe how you would investigate the distribution of charge on a pear-shaped conductor.
- (e) Explain how a charged body attracts uncharged conductor.
- (f) Describe how an electroscope can be used to distinguish a conductor from an insulator.
10. (a) Define **dielectric strength**.
- (b) (i) Explain briefly how a capacitor in which the potential difference V_0 across the plates, can be fully discharged.
- (ii) Sketch a graph showing a variation of potential difference with time for the process on (b)(i) above.
- (c) (i) Two capacitors of capacitance C_1 and C_2 are connected in series. Show that the effective capacitance, C is given by
- $$C = \frac{C_1 C_2}{C_1 + C_2}$$
- (ii) A $10.0\mu\text{F}$ capacitor charged to 200V is connected across an unchanged $50\mu\text{F}$ capacitor.
- (iii) Account for the difference in the energies calculated in (c) (ii) above.

- (d) In Figure 7, Q_1 and Q_2 are point charges of magnitudes $+5.0\mu\text{C}$ and $-5.0\mu\text{C}$ respectively.

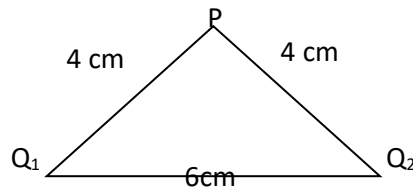

Figure 7

Calculate the:

- (i) Electric field intensity
- (ii) Potential energy of a point charge Q_3 of $0.8\mu\text{C}$ placed at P.

2008

1. (a)
 - i) Distinguish between real and virtual images (2mks)
 - ii. Describe how the position of an image in a pipe mirror can be located
- b) The diagram in figure 1 below shows a ray of light undergoing two successive reflections at points X and Y in two mirrors M_1 and M_2 inclined at an angle θ

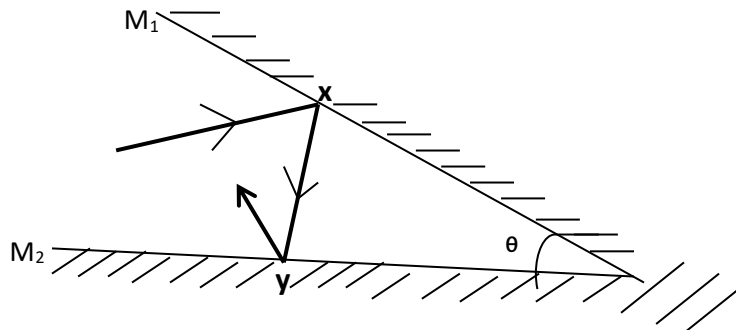

Fig 1.

Show that the ray is deviated through an angle 2θ . (3mks)

- c)
 - i) What is radius of curvature of a convex mirror?
 - ii) Describe the experiment to determine the focal length of a convex mirror using a plane mirror.
- d) A small convex mirror is placed 0.60m from the pole and on the axis of the length concave mirror of radius of curvature 20m. The position of the convex mirror is such that a real image of a distant object is formed in the plane of a hole drilled through the convex mirror at its pole. Calculate the radius of curvature of

the convex mirror at its pol. Calculate the radius of curvature to the convex mirror.

- e) State four advantages of reflecting telescope over the refracting type.
2. a) i) What is a wave
ii) Explain why an open tube is preferred to a close tube as a musical instrument
- b) i) State two factors that affect the speed of sound in air
ii) Explain the term reverberation
iii) What are implications of reverberation in a concert hall?
- c) Describe an experiment to document the velocity of sound in air using the resonance method.
- d) i) What is a harmonic sound?
ii) A string of length 0.50m and mass 5.0g is stretched between two fixed points. If the tension in the string is 100N, find the frequency of the second harmonic.
3. a) i) Define the term linear magnification and angular magnifications as applied to a less
ii) Derive the expression for the magnifying power of a magnifying glass when the final image is formed at the near point.
- b) An object is placed at a distance $F + x$ from a conveying lens of focal length, F , the lens produces an image at distance, $f + x$ from the lens. Show that
- $$f^2 = xy$$
- c) i) Describe with the aid of a labeled diagram, the structure and operation of a simple projection lantern.
ii) The slide of a projection lantern has dimension 36mm by 24mm. find the focal length of the lens required to project an image 1.44m by 0.98 on a screen placed 4.0m from the lens.
- d) Distinguish between a chromatic and spherical aberration.
4. a) Distinguish between constructive and destructive interference
- b) i) Explain how interference fingers are formed in an air wedge firm between two glass slides when monochromatic light is used.

- ii) Describe the appearance of the fringes when white light is used.
- c) Two glass plates in contact at one end are separated by a sheet of paper 15cm from line to contact to form an air-wedge. When the air-wedge is illuminated normally by light of wavelength 6.0×10^{-7} m, interference fringes of separation 1.8mm are found in reflection.
- d) i) Describe with the aid of a labeled diagram, one method of producing plane polarized light.
ii) State two uses of polarized light.

SECTION B

- 5. a) Define
 - i. The tesla
 - ii. Magnetic flux
 - b. Two infinitely long straight wires carrying current, I_1 and I_2 respectively are placed parallel to each other in a vacuum at a distance, d meters apart. Derive an expression for the force per meter between the wires.
 - c) i) Sketch the magnetic field pattern due to current flowing in a circular coil.
ii) Write an expression for magnetic flux density, B , at the centre of a circular coil of N turns each of radius r and carrying a current I .
iii) A wire of length 7.85m is wound into a circular coil of radius 0.05m. if a current of 2A passes through the coil, find the magnetic flux density at the centre of the coil.
 - d) i) Explain the term back e.m.f in a d.c motor
ii) Show how the back e.m.f in a motor is related to the efficiency of the motor.
- 6. a) i) Define the term amplitude and root mean square (r.m.s) of an alternating Current
ii) Show that the r.m.s value I_{rms} of an alternating current of amplitude I_0 is given by

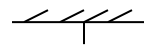
$$I_{rms} = 0.707I_0$$

A small magnet is attached to a spring as shown in figure 2 switch, k is closed and the magnet is displaced downwards slightly and reused to oscillate vertically. Explain

- i) the observation made
 - ii) Why the magnetic takes long to come to rest when, k is opened.
- c) A sinusoidal voltage of r.m.s value of 10V is supplied across a 50 μ F capacity.
- i) Find the peak value of the charge on the capacitor.
 - ii) Draw a sketch graph of a charge Q on the capacity against time.
 - iii) Draw on the same sketch in (c) (ii) a graph of current against time.
 - iv) If the a.c supply has a frequency of 50HZ, calculate the r.m.s value of the current through the capacitor.
7. a) i) Distinguish between self induction and mutual induction
- ii) An air-cored inductor is connected in series with a switch and a d.c source. The switch is closed and left for some time Explain why a spark is observed across the switch contacts when the switch is re-opened.
- b) Describe with the aid of a diagram, how the magnetic flux density between the poles of a strong magnet can be measured
- c) i) Explain how eddy currents are produced
- ii) Explain one application of eddy currents
- d) A coil of 500 turns and mean area $4 \times 10^{-2}m^2$ is rotated at a uniform rate of 600 revolutions per minute about an axis perpendicular to a uniform magnetic field of flux density 0.27 Calculate the maximum value of the e.m.f induced in the coil.

SECTION C

8. a) i) Derive the formula for the combined resistance of three resistors series .
 ii) Explain why a metal becomes hot when an electric current flows through it.
 iii) What advantages does the potentiometer have over the stone bridge when used to compare two low resistances?

b)

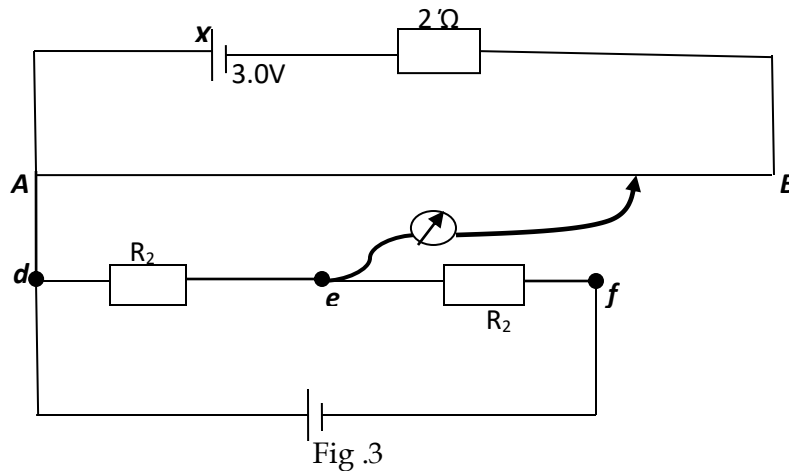

In the figure 3, AB is a slide wire of length 1.0m and resistance 10Ω , X is a driver cell of e.m.f 3.0V and negligible internal resistance. When the centre-zero galvanometer is connected in turns to point's e and f the balance length obtained are 45.0 and 80.0cm respectively.

Calculate the

- i) current flowing through R_1
 ii) resistance of R_1 and R_2
- c) Describe with the aid of a diagram, how a calibrated slide wire potentiometer may be used to measure thermoelectric e.m.f
9. a) Explain why a redistribution of charge occurs on uncharged slide rod when positively charged metal sphere is brought near to one end.
 b) Sketch a graph showing the variation of potential

- i) Relative to the earth along the axis of the metal rod in (a) from the center of the recharged sphere to the furthest end of the rod
- ii) Along the axis of the rod in (a) from the center to the surface of the conductor.
- c) Explain why the electric field intensive close to the surface of a charged conductor is always at right angles to the surface of the conductor.
- d) Describe with the aid of the diagram the mode of operation of the Van der Graff generator
- e) A proton is fired from infinity with the speed of $3.7 \times 10^6 m^{-1}$ towards a stationary charge of $+50e$. Calculate the speed of the proton at a point $10^{12}m$ from the stationary charge.

10. a) i) What is meant by a direct material?
- iii) Explain the effect of a dielectric on the capacitance of a capacitor.
 - b) Two capacities C_1 and C_2 are connected in series with a battery on e.m.f, V show that the p.d, V_1 across the capacitor of capacitance C_1 is given by

$$V_1 = \left(\frac{C_2}{C_1 + C_2} \right) V$$

C)

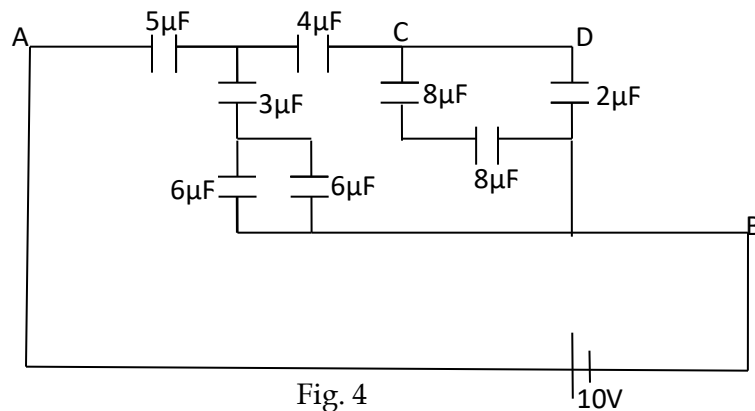

Figure 4 shows a network of capacitors connected to a 10V battery calculate the total energy stored in the network.

- d) Describe how the unknown capacities of a capacitors can be determined using a ballistic galvanometer.

Physics paper two 2007

- 1
 - a.
 - i) State the laws of reflection
 - ii) Show that the image formed in a plane mirror is as far behind the mirror as the object is in front
 - b.
 - i) Draw a ray diagram to show how a concave mirror forms a real image of a real object placed perpendicular to its principal axis.
 - ii) Describe an experiment, including a graphical analysis of the results to determine the focal length of a concave mirror using the No-parallax method.
 - c) Concave mirror M of focal length 20.0cm is placed 90cm in front of a concave mirror, N, of focal length 12.5 cm. an object is placed on the common axis of M and N at a point 25.0cm in front of M
 - i) Determine the distance from N of the image formed by reflection, first in M and then in N
 - ii) Find the magnification of the image formed in (c)(i) above
2.
 - a) What is meant by reversibility of light as applied to formation of a real image by a convex lens
 - b).
 - i) Draw a ray diagram to show the action of an astronomical telescope in normal adjustment
 - ii) Derive the expression for the magnifying power of the telescope in (b) (i) above in term of the focal length f_o and f_e of the objective and eyepiece respectively. Find the objective and eyepiece respectively
 - iii. The objective and eyepiece of an astronomical telescope have focal length of 75.0cm image is 25cm from the eyepiece.
 - c) What is the significance of the reflecting telescope in a simple microscope?
3.
 - a) State three differences between sound and light waves
 - b) Distinguish between free and damped oscillations
 - c)
 - i) What is meant by resonance?

ii) Describe with the aid of the diagram, an experiment to investigate the variation of frequency of a stretched string with length

- d) i) Calculate the frequency of beats heard by a stationary observer when a source of sound of frequency 80 Hz is receding with the speed of 5.0 ms^{-1} towards a vertical wall.

$$\text{speed of sound in air} = 340 \text{ ms}^{-1}$$

ii) State two uses of beats

- 4 a) State Huygens's principle
- b) Monochromatic light propagating in air is incident obliquely onto a plane boundary with a dielectric of refractive index, n .
- i) Use Huygens's principle to show that the speed, V , of the light in the dielectric is given by $V = \frac{c}{n}$ Where c is speed of light.
- ii) If the wavelength of the light is 600 nm in air what will it be in a dielectric of refractive index 1.50?
- c) i) What is meant by interference of waves?
- ii) State the conditions necessary for interference fringes to be observed in the case of two wave-motions
- d) Two glass slides in contact at one end are separated by a wire of diameter 0.04 mm at the other end to form a wedge. Fringes are observed when light of wavelength $5.0 \times 10^{-7} \text{ m}$ is incident normally on the slides. Find the number of fringes which can be observed.

SECTION B

- 5 a) what is a magnetic field?

b)

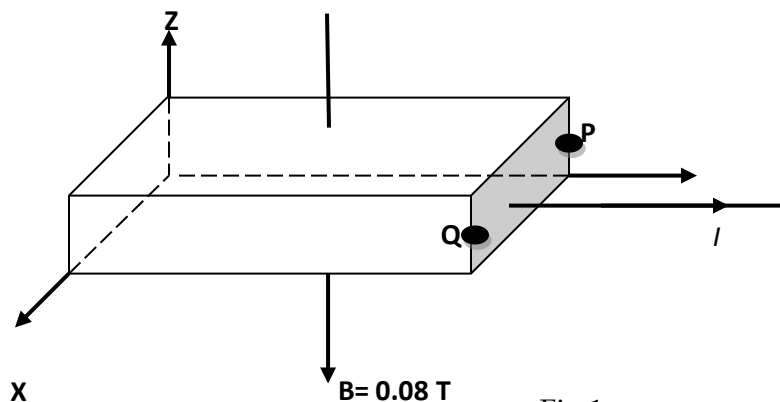
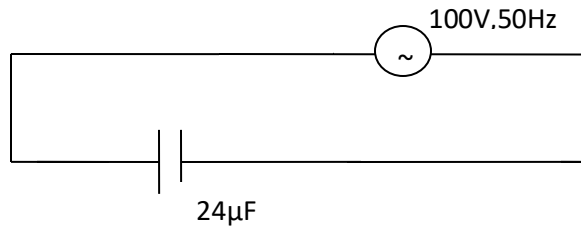

Fig 1.

A magnetic field of flux density 0.08 T is applied normally to a metal strip carrying, I as shown in figure 1.

- i) Account for the occurrence of potential difference (p.d) between points P and Q.
 - ii) Calculate the electric field intensity P and Q if the actions of a moving coil galvanometer.
- c) i). Describe with the aid of diagram the structure and mode of action of a moving coil galvanometer
- ii) Explain how the design of the moving coil galvanometer can be modified to produce a ballistic galvanometer
- d) A flat coil X of 30 turns and mean diameter 30cm is fixed in a vertical plane and carries current of 3A
- Another coil Y of 2cm×2cm and having 20turns is suspended in a vertical plane at the center of the circular coil. Initially the planes of the two coils are perpendicular. Determine the torque on coil Y when a current of 2.0 is passed through it.
- 6 a) i) Describe an experiment to demonstrate the damping effect of eddy current
- ii) Give two practical applications of this effect.
- b) What is meant by?
- i) Self-induction?
 - ii) Mutual induction?
- c) Discuss the factors which determine the maximum coil. The primary coil is connected to 240 V AC. A 12V, 36W lamp is connected to the secondary coil, if the efficiency of the transformer is 90% determine
- i) Number of turns in the secondary coil
 - ii) current flowing in the primary coil
7. a) i) Define root mean square value of an alternating current
- ii) A resistor of 400Ω is connected to 240V a.c supply
- What is the peak value of the current flowing through the resistor?
- (b) A 60W, 30V bulb, and coil of inductance 5H are connected in series to a battery of 30V as shown in figure 2

- i) What is observed when , K, is closed and when it is opened Explain your observation in
 - ii) Explain your observation in (b)(i)
- c) With the aid of a labeled diagram, describe how a repulsive to of moving iron ammeter works.



- d) A 100V, 50 HZ a.c. supply is connected across a capacitor of $24\mu F$ as show in figure 3
- i) Calculate the reactance of a the circuit
 - ii) Sketch graphs to show the time dependence of the rap voltage and the current in the circuit.

Section c

- 8(a) i) State coulomb's law of electrostatics
- iii) Define term electric field intensity and electric potential at a point.
- b) Sketch graphs of the variation of electric potential and electric field intensity with distance from the center of charged conducting sphere
- c) Charges q_1 and q_2 of $5.0\mu C$ and $2.0\mu C$ respectively are placed at two opposite corners of a rectangle 5cm and 10 cm as shown in figure 4.

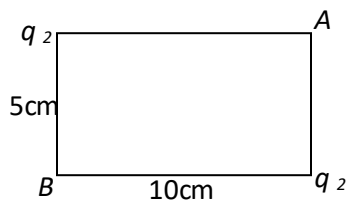

Fig.4

Calculate the

- i) Electric potential
 - ii) Electric field intensity at A
- d) i) What is meant by corona discharge?
- ii) Explain how the lightning conductor works

9 (a) Define current density and the ohm and state their units

b) i) Sketch the current versus voltage characteristics for a gas discharge tube.

ii) Explain the main features of the graph in (b) (i)

c)

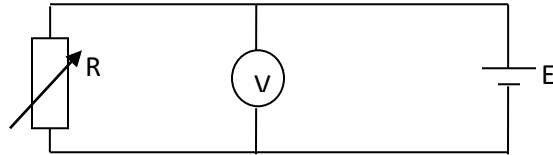

Fig. 5

Figure 5 shows a cell of e.m.f, E and internal resistance r , connected to a voltmeter V and variable resistor R . Explain how the value of V varies with R .

d)

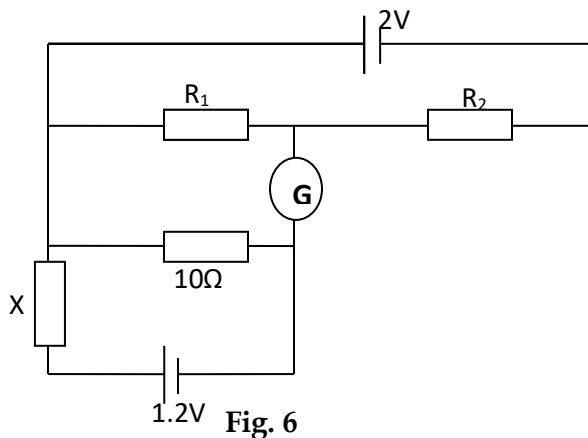

Fig. 6

In figure 6, R_1 and R_2 are resistors of 10Ω and 90Ω respectively. If the cells have negligible internal resistances, find the value of X for which G shows no deflection.

e) Describe how the internal resistance of a cell can be measured using slide wire potentiometer.

10. a) i) Define capacitance and state its units

ii) With the aid of a labeled diagram, describe an experiment to measure capacities of a capacitor

b) A capacitor is charged by a 30V d.c supply. When the capacitor is fully charged, it is found to carry charge of $5.0\mu\text{C}$. Calculate the

i) Capacitance of the capacitor

ii) Energy stored in the capacitor

- c) Derive the expression for the effective capacitance of three capacitors of capacitance C_1, C_2 and C_3 respectively connected in series.
- d) Describe briefly an experiment to show the effect of varying the distance of separation of the plates of a capacitor on capacitance.

Physics paper two 2006

- 1 a) i) What is meant by amplitude and wavelength as applied to waves?
 ii. State the difference between progressive and stationary waves
- b) The displacement y_2 of a wave travelling in the x- direction is given at time, t, by

$$y = a \sin 2\pi \left(\frac{t}{0.5} - \frac{x}{2.0} \right) \text{ Meters}$$
 Find the speed of the wave.
- c) i) What is meant by the terms overtones and beats?
 ii) State two uses of beats
 iii) A tube 1m long closed at one end is lowest resonance frequency at 86.2HZ. With a tube of identical dimension but open at both ends. The first resonance occurs at 171HZ.
- 2 a) i) calculate the speed of sound and the end correction
 ii. What is meant by refraction of light?
 iii) State the laws of refraction
- b) Describe how the refractive index of a liquid can be determined using concave mirror
 c)

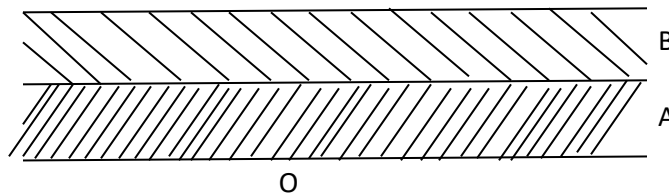

Fig 1.

The parallel sided blocks A and B of thickness 4.0cm and 5.0cm respectively are arranged such that A lies on an object O as shown

Figure 1

Calculate the apparent displacement of when observed from above, if the refractive indices of A and B are 1.52 and 1.66 respectively.

d) i) State two applications of total internal reflection

ii)

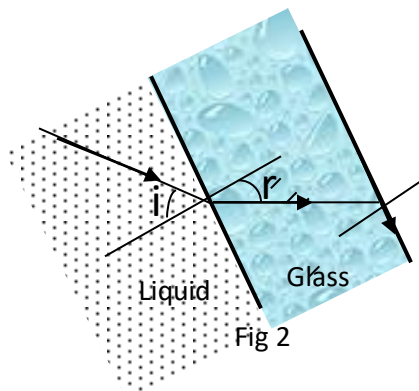

In figure 2, a parallel sided is in contact with a liquid on one side and air on the other side. A ray of light incident on the glass slide from the liquid emerges in air along the glass-air interface.

Derive an expression for the absolute refraction, n_1 , of the liquid in terms of the absolute refractive index, n , of glass and angle of incidence, i

3 a) i) Define angular magnification of a compound microscope

ii. Draw a labeled ray diagram to show how two converging lenses can be used to make a compound microscope in normal adjustment.

b) An object size 2.0mm is placed 3.0cm in front of the objective of a compound microscope. The focal length of the objective is 2.5cm while that of the eye-piece is 5.0cm. The microscope forms a virtual image of the object at the near point of the eye. Find the

i) Size of the final image

ii) Position of the eye-ring.

c) i) With the aid of a labeled diagram, describe the essential parts of a photographic camera

ii) Explain how chromatic and spherical aberration are minimized in the photographic camera.

4a) i) State the superposition principle as applied to wave motion

ii. What is meant by optical path?

b) i) State the conditions which must be satisfied in order to observe an interference pattern due to two waves.

ii) Explain why an oil film on a water surface appears to be colored.

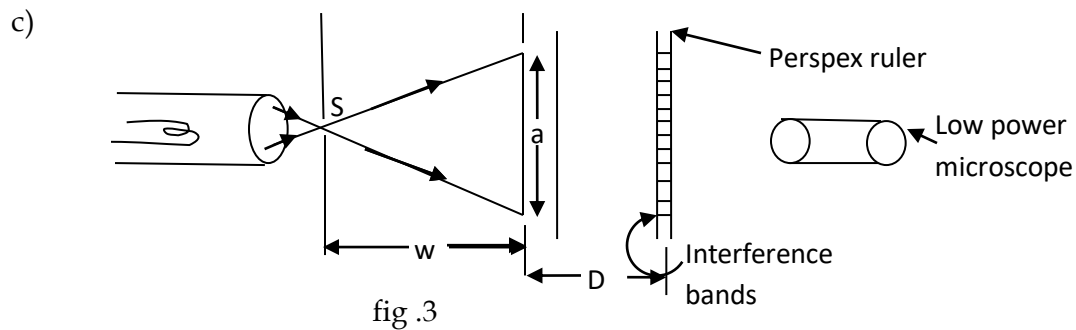

Figure 3 shows an experimental set up to demonstrate Young's interference fringes. Explain what is observed when the

- i) Slit x is covered
- ii) Slit S is widened
- iii) Separation , d of the slits X and Y is reduced keeping W fixed
- iv) Distance ,W, is reduced

d) Monochromatic light of wavelength 600nm is incident normally on a plane diffraction grating 500lines per num

Calculate the

- i) Number of diffraction maximum observed
- ii) Angular position of the first diffraction maximum.
- iii)

SECTION B

5. a) Define magnetic flux density and state its unit
- b) Describe how the magnetic flux density between the poles of a powerful magnet can be determined
- c) i) Explain with the aid of a sketch, the terms angle of dip and declination
- ii) Explain what happens to the angle of dip as one move along same longitude from the Equator to the North Pole

- iv) Find the force per unit length on a straight horizontal wire carrying a current of 2.0 A in the direction north to south. If the angle of dip is 70° and the earth's horizontal field component is 1.6×10^{-5} T

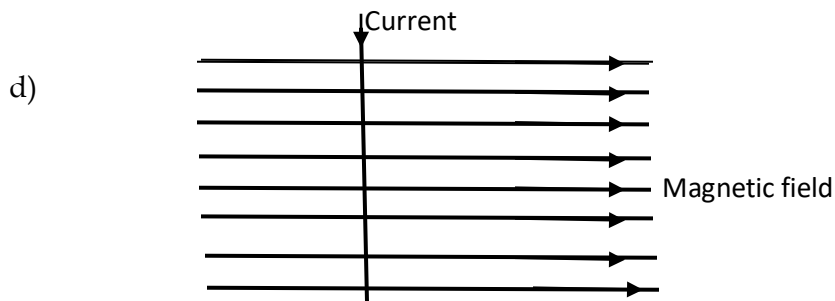

Fig 4

A wire is placed vertically in a horizontal magnetic field as shown in figure. Sketch the resultant magnetic field pattern.

- 6a) i) with the aid of a diagram, describe how a simple d.c motor works.
 ii. Explain the significance of a back e.m.f in the operation of a d.c motor
- b) A motor of armature resistance 0.75Ω is operated from 240V dc supply.
- i) When the motor turns freely without a load, the current in the armature is 4.0A and the motor makes 400 revolutions per minute. Calculate back e.m.f
 ii) When a load is placed in the motor, the armature current increases to 60.0A. Find the new speed of rotation of the motor.
- c) i) A circular coil of 10 turns and radius 5.0cm carries a current of 1.0A. Find the magnetic flux density at its center.
 ii) A copper wire of cross-sectional area 1.5 mm^2 carries a current of 5.0A. The wire placed perpendicular to a magnetic field of flux density 0.2T. If the density of free electrons in the wire is 10^{20} m^{-3} . Calculate the force on each electron.
- 7a) define the terms root mean-square value, peak value of an alternating current and derive the relation between them for a sinusoidal a.c
 b) Derive an expression for the reactance of a the inductor

ii) Using the same axes, sketch graphs to show the relative phases of the current and voltage across the inductor.

c)

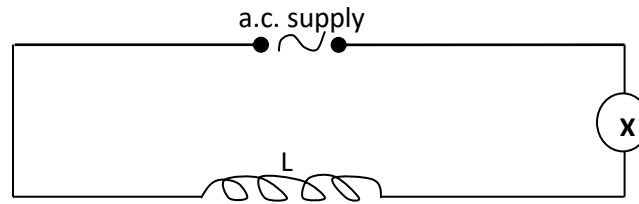

Figure 5 shows a circuit consisting of an air-cored coil L , a bulb, X , and an alternating voltage source connected in series. An iron core is introduced into the coil. Explain why the

- i) bulb becomes dimmer
 - ii. iron core becomes warm
- d) Explain why a moving coil ammeter cannot be used to measure an alternating current from the mains

SECTION C

8 a) Define the terms electrical resistivity and temperature coefficient of resistance

b) i) Explain why the temperature coefficient of resistance is positive for metals

ii) What are super conductors?

c) i) The temperature coefficient of resistance of two wires A and B of diameters 1.20mm and 0.80mm are $0.0004K^{-1}$ and $0.0003K^{-1}$ respectively. If the ratio of their resistance at $0^{\circ}C$ is 15. Calculate

i) The ratio of the resistance at $100^{\circ}C$

ii) The ratio of the resistances at $100^{\circ}C$ given that they have the same length

d) i) Derive the balance conditions for wheat stone bridge

ii) Explain why the wheat stone bridge is not suitable for measuring very low or very high resistance

9. a) i) Define electric potential and electric fields intensity

ii) What is the relation between electric potential and electric field intensity?

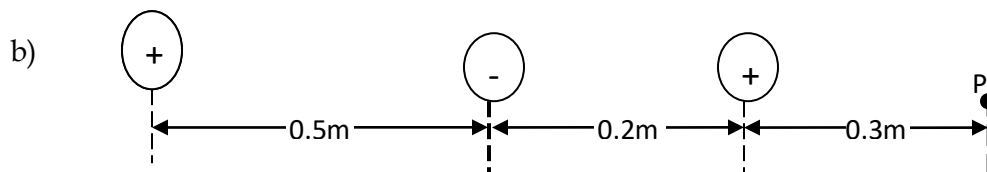

Fig. 6

Three point charges of $+6.4\mu\text{C}$ and $+3.2\mu\text{C}$ are arranged in line as shown in the figure 6 find the electric fields intensity at P

- c) i) Explain with the aid of a diagram, how a charged body can be screened against external electric fields.
- ii) Describe briefly how the sign of a charge on a given body can be detected using a gold leaf electroscope.
- iii. What is meant by action at points in electrostatics?

10 a) Define the farad

b) Describe the energy transformation that takes place when charging a capacitor using a dry cell

c) The capacitance of a variable radio capacitor can be changed continuously from 10pF to 900pF by turning the dial from 0° to 140° . With the dial set at 140° the capacitor is disconnected from the battery and the dial is turned to 0° calculate the

i) Charge on the capacitor

ii) Energy stored in the capacitor with the dial set at 140°

iii) work required to turn the dial from 140° to 0° if friction is neglected

d) Describe an experiment to determine the effect of an area of overlap on the capacitance of a parallel plate capacitor

e) Explain why the capacitance of a capacitor changes when a dielectric is placed between its plates

Physics paper two 2005

1. a) Define the focal length of a concave mirror

b) An object is placed at a distance u from a concave mirror. The mirror forms an image of the object at a distance v . draw ray diagram to show the path of light rays when the image formed is

i) Real

ii) Virtual

c) Use a geometrical ray diagram to derive the relation $\frac{1}{v} + \frac{1}{u} = \frac{1}{f}$ for the concave mirror.

- d) A concave mirror of radius of curvature 40.0 cm contains a liquid height of 2.0cm. a pin clamped horizontally and viewed from above is observed to coincided with its image when it is 27.0cm above the surface of the liquid. Calculate the refraction index of the liquid.
- e) You are provided with the following pieces of apparatus:
A screen with cross-wire, a lamp, a concave mirror, and a meter rule
Describe n experiment to determine the focal length of the concave mirror using the above apparatus.
2. a) Distinguish between progressive and stationary waves
b) Briefly describe an experiment to show that a wire under tension can vibrate with more than one frequency
c) A uniform wire of length 1.00m and mass 2.010^{-2} kg is stretched between two fixed points. The tension in the wire is 200N.
The wire is plucked in the middle and released. Calculate the
i) Speed of the transverse waves
ii) Frequency of the fundamental note
d) i) Explain how beats are formed
ii) Derive an expression for the beat frequency.
3. a) i) Explain the terms chromatic and spherical aberrations, in lenses .
ii) How are the aberrations in (i)above minimized in a reflecting telescope
b) With the aid of a diagram, explain why the image seen in a magnifying glass is almost free from chromatic aberration when the eye is close to the lens.
c) A converging lens is used to form an image of an object 1.2m away on the screen 0.05m from the lens.
i) Find the focal length of the lens
ii) If the lens is now used to form an image of a distant object how far from the screen would the clear image be formed?
iii) State the type of lens that should be places close to the first lens in order to enable the image in (ii) above to be forms on the screen
iv) Calculate the focal length of the lens you have state in (iii) above

4. a) Distinguish between longitudinal and transverse waves
 b) i) Describe the method of producing plane-polarized light reflection
 ii) Mention two practical application of plane polarized light, and describe one of them
 c) i) State the conditions necessary for the formation of standing waves
 ii) A uniform tube, 50cm is filled with water and a vibrating tuning fork for frequency 512HZ is sounded and held above it. When the level of water is gradually lowered, the air column resonates with the tuning fork when its length is 12cm and again when it is 43.3cm.
 Estimate the lowest frequency to which the air in the tube could resonate if the tube were empty.

SECTION B

5. a) Define magnetic flux density
 b) Two identical coils are placed coaxially at a distance equal to the radius of each coil
 i) Sketch the magnetic field pattern which results when equal currents are passed through the coils
 ii) Describe how you investigate the variation of magnetic flux density with the distance along the axis of the coils
 Draw a sketch graph to show the expected results
 c) A small rectangular coil of 10 turns and dimensions 4cm by 2cm is suspended inside a long solenoid of 1000 turns per meter so that its plane lies along the axis of the solenoid as shown in figure 1.

The coil is connected in series with the solenoid.

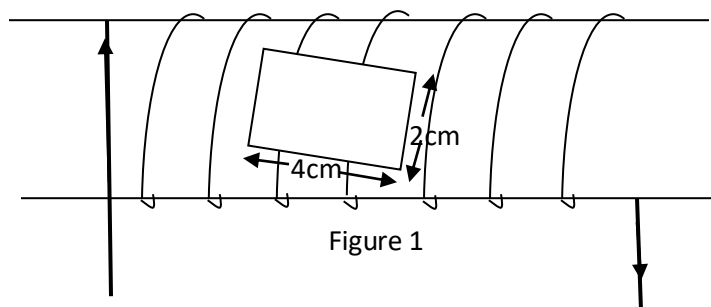

The coil deflects through 30° when a current of 2A is passed through the solenoid.
 Find the torsion constant of the suspension

- d) A moving coil galvanometer reads 15mA when it is connected in series with a source of e.m.f of negligible internal resistance and a resistor of resistance 100Ω the galvanometer reads 10mA when the 100Ω resistor is placed with one of resistance 200Ω find the
- resistance of the galvanometer
 - e.m.f of the source.
6. a) State the laws of electromagnetic induction
- b) A coil of 100 turns is wound round the middle of along solenoid of 500 turns per meter and radius 8.0cm
A sinusoidal current $I = 10 \sin(120\pi t)$, amperes, is passed through the solenoid winding.
Find the amplitude of the e.m.f induced across the terminal of the coil.
- With the aid of a labeled diagram, describe the structure and action of a simple d.c motor.
 - Explain the term back e.m.f in a motor and derive its relation to the efficiency of the motor
 - Briefly explain one application of eddy currents
7. a) i) Describe, with the aid of a labeled diagram, the structure and mode of operation of an a.c generator
- Explain the structural modification needed to convert an a.c generator into a d.c generator.
 - Define the term speak value and root mean square (r.m.s) value of an alternating voltage
 - An electric kettle draws 1.5×10^3 W from a 240V mains supply. Find the peak value of the current drawn by the kettle if the voltage is sinusoidal.
 - A alternating voltage of 12V and variable frequency f , is connected in series with a capacitor of a capacitance, C
 - Explain why current apparently flows through the capacitor
 - Calculate the value of the current in the circuit when f and C are 1 kHz and 0.5 respectively.

SECTION C

8. a) i) Define a volt

- ii. Derive the formula for the combined resistance of three resistors in parallel

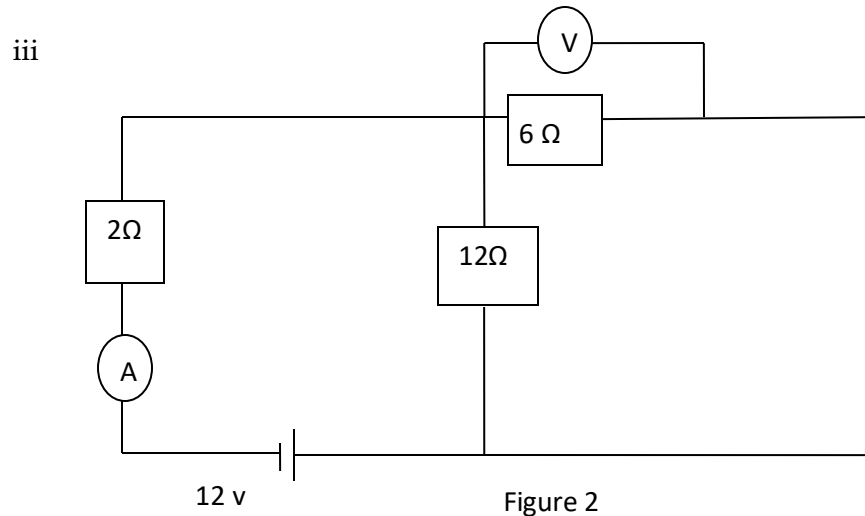

In the circuit in figure 2, the battery has negligible internal resistance. Find the ammeter and voltmeter readings

- b) i. Draw a labeled diagram of a meter bridge and derive the condition for balance
 ii) Explain why the balance point should be close to the middle of the wire .
 c) A coil of wire has resistance of 30Ω at 20°C at 60°C

Calculate its temperature coefficient of resistance

9. a) Explain the principle of a slide wire potentiometer
 b) i) Using a labeled diagram, describe how an ammeter is calibrated using a slide wire potentiometer
 ii) What is the advantage of the potentiometer over an ordinary voltmeter in measurement of voltage?
 c) Two cells A and B connected in series; give a balance of length of 758mm along a potentiometer wire. When cell B is reserved, the balance length falls to 123mm. if the e.m.f of the cell is 1.5V, calculate the e.m.f of the cell B.

- d) The resistance of a nichrome element of an electric fire is 50.9Ω at 20.0°C . When 240V supply, the current flowing through it is 4.17A . Calculate the steady temperature reached by the electric fire if the temperature coefficient of resistance of nichrome is $1.7 \times 10^{-4}\text{K}^{-1}$.
10. a) Explain the meaning of an equipotential surface as applied to electric field.
 b) With the aid of a diagram, describe an experiment to show that excess charge resided only on the outside surface of a hollow conductor
 c) State coulomb's law of electrostatics
 d)

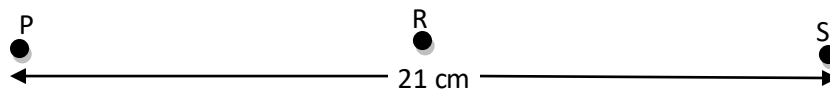

Figure 3

Two point's charges P and S of $-17.6\mu\text{C}$ and $-9.0\mu\text{C}$ respectively are placed in vacuum at a distance of 21cm apart. When a third charge, R, is placed mid-way between P and S as shown in figure 3 above, the net force on S is zero

- i) Determine the charge on R
- ii) Calculate the electric potential at the point of R
- iii) Sketch the electric field lines corresponding to the charge distribution

Physics paper two 2004.

1. a) What is meant by the following terms as applied to telescope?
 - i) Magnifying power
 - ii) Eye-ring
- b) i) Draw a ray diagram to show the information of the final image by an astronomical telescope in normal adjustment
 - ii) With the aid of a diagram in (b)(i), derive an expression for the magnifying telescope in normal adjustment.
 - iii) Give the disadvantages of the telescope in (b)(i) when used to view distant objects on earth. Describe how the telescope can be modified to overcome this advantage.

- c) Find the separation of the eye piece and objective of an astronomical telescope of magnifying power 20 and in normal adjustment, if its eyepiece has a focal length of 5cm.
- d) State three advantage of a reflecting telescope over a refracting telescope.
2. a) Define the terms principle focus and power of a lens
- b) Derive the relation between the focal length, f , object distance, u , and image distance, V , for a thin lens.
- c) A thin converging lens, P , of focal length 10cm and thin diverging lens Q , of focal length 15cm are placed coaxially 50cm part. If an object, O , is placed from P on the side remote from Q
- i) Find the position, nature and magnification of the final image
- ii) Sketch a ray diagram to show the information of the finite image
- d) Explain why lenses of narrow aperture are preferred to lenses of wide aperture in optical instruments
3. a) i) What is meant by polarized light?
- ii) Describe how plane polarized light can be produced
- iii. Sketch the time variation of electric and magnetic vectors in a plane polarized light wave
- b) Two coherent source a distance, s , apart produced light of wavelength, λ , which overlap at a point on a screen a distance, D , from the source to form an interference pattern
- i) What is meant by coherent sources?
- ii. Show that the fringe width, ω , is given by $\omega = \frac{\lambda D}{s}$
- iv) If $\lambda = 5.46 \times 10^{-7}m$, $S = 5 \times 10^{-5}m$ and $D = 0.3m$, find the angular position of the first dark fringe on the screen
- c) i) What is meant by diffraction of light?
- ii) Light of wave length $6 \times 10^{-7}m$ is incident on diffraction grating with 500lines per cm. find the diffraction angle for first order image.
4. a) i) Distinguish between transverse and longitudinal waves
- ii. Define wavelength of a wave
- b) Describe, with aid of diagram, an experiment to show the fundamental frequency varies with tension in a given wire.
- c) A sound wane probating in the x-direction is given by the equation

$$y = 2 \times 10^{-7} \sin 8000t - 25x \text{ meters Find}$$

- i) The amplitude
- ii) The speed, of the wave
- d) Explain why the amplitude of a wave goes on decreasing as the distance from the source increases.

SECTION B.

5a) with the aid of a diagram, describe briefly an experiment to illustrate Lenz's Law of electromagnetic induction

b) Explain the main precautions taken in the construction of and a.c transformer

c) Explain the effect of the following on the across the secondary coil of a.c transformer

i) A fall in the supply frequency of the current in the primary

ii) A reduction in the primary turns

d) A transformer whose secondary coil has 60 turns and primary 1200 turns. Has its secondary connected to a 3Ω resistor? If its primary is connected to a 240 a.c. calculate the current flowing in the primary assuming that the transformer is 80% efficient

6. a) When can an alternating current be referred to as being sinusoidal?

b) Define:

(i) The root mean square value of an alternating current

ii) Reactance

c) i) Show that current leads voltage by 90° when a sinusoidal voltage is applied across a capacitor

ii) Sketch a phasor diagram to illustrate the orientation of the current vector with respect to the voltage vector in (d)(i)

e)

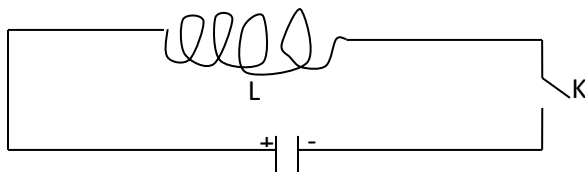

Figure 1

An inductor, L, a capacitor, C and switch, K are connected as shown in figure 1, Explain briefly what happens when the switch is closed

7. a) What is meant by magnetic meridian?
- b) i) Describe the effect of eddy currents in a dynamo and state how they can be reduced?
 ii) Explain why eddy current are useful in a moving coil galvanometer
 iii) What is the difference between a motor and a dynamo
- c) Describe how a search coil and a calibrated ballistic galvanometer can be used to measure magnetic flux density at a given point near a wire carrying direct current.
- d) An aircraft is flying horizontally at 800kmh^{-1} at a point where the earth's magnetic flux density is $2.31 \times 10^{-5}\text{T}$ and the angle of dip is 60° . If the distance between the wing tips is 50cm, calculate the potential difference between its wing tips.

SECTION C

8. a) i) Define electrical resistivity and state its units
 ii) Describe with the aid of a circuit diagram, an experiment to determine the electrical resistivity of a given wire using a meter bridge.
 iii. The resistivity of mild steel is $15 \times 10^{-8}\Omega\text{mat}20^\circ\text{C}$ and its temperature coefficient is $50 \times 10^{-4}\text{K}^{-1}$. calculate the resistivity at 60°C

b)

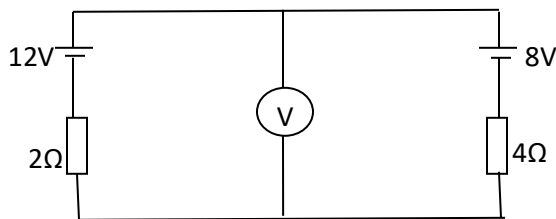

Fig. 2

Resistors of 2Ω and 4Ω are connected in series with power supplies of 12V and 8V as shown in figure 2. Calculate

- i) The reading of the voltmeter
 ii) The power dissipated in the 4Ω resistor
9. a) Define the following terms
- i. Capacitance of a capacitor
 - ii. dielectric constant
- b) Explain the effect of a dielectric on the capacitance of a capacitor
- c) Derive an expression for the energy stored in a capacitor of capacitance, charged to a voltage, V

d)

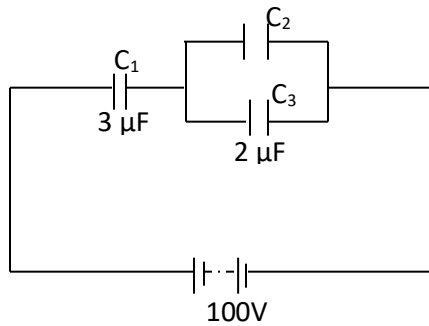

Figure 3

In figure 3, C_1 , C_2 and C_3 are capacities $3\mu\text{F}$, $2\mu\text{F}$ and $2\mu\text{F}$ respectively, connected to a battery of e.m.f 100V

- i) Calculate the energy stored in the system of capacitors if the space between the plates of C_1 is filled with an insulator of dielectric constant 3 and the capacitors are fully charged.
- ii) Account for the change in the energy stored by an isolated parallel-plate capacitor when the plate separation is doubled

10 a) i) Define the terms electromotive force and volt

ii. Why should the temperature of a conductor increase when the current passes through it?

b) Describe how a potentiometer can be used to calibrate a voltmeter

c)

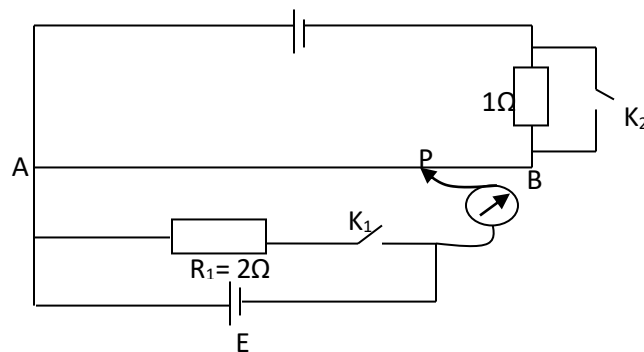

Fig 4

In the figure 4, AB is uniform resistance wire of resistance 4Ω and length 100cm. E is a cell of e.m.f 15V: D is a driver cell negligible internal resistance. When switch K is closed and switch k_1 is open, the balance length AP is 60cm. when both k_1 and k_2 closed, the balance length is 35cm find:

- i) The internal resistance of E
 - ii) The balance length when k_1 is closed and k_2 is open
- d) Explain what happens when the e.m.f of cell E is greater than that D and k_2 is closed while k_1 is open

Physics paper two 2003

- 1a) i) State the laws of reflection of light
- ii. Show that an incident ray of light reflected successively from two mirrors inclined at an angle to each other, is rotated through an angle 2θ
 - b) Describe how a sextant is used to determine the angle of elevation of a star
 - c) i) Describe an experiment to measure the focal length of a convex mirror
- iii) A concave lens of focal length 20cm is placed 10cm in front of a concave mirror of focal length 16cm.
Calculate the distance from the lens at which an object would coincide with the image

- 2 a) Define the wavelength of a wave
- b) A source of sound moving with velocity u_0 in the same direction. Derive the expression for the frequency of sound heard by the observer
- c) Explain what happens to the pitch of the sound heard by the observe in (b) above when the
 - i) Observer moves faster than the source
 - ii. Observer's velocity is equal to that of the sound.
- d) State and explain one application of Doffer effect .
- e) The wire of a guitar of length 50cm and mass per meter 1.5×10^{-2} kg, under tension of 173.4N. if it is plucked at its mid-point, find the
 - i) Frequency
 - ii) Wavelength, of the fundamental note
- 3a) Explain, with the aid of a diagram, why a thick plane mirror forms multiple images

b) Derive the expression for the focal length of a combination of two thin converging lenses in contact, in terms of their focal lengths.

c)

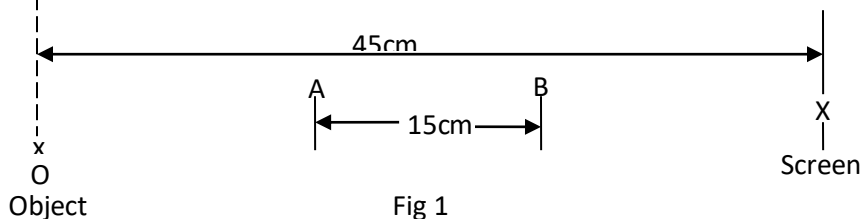

Fig 1

In the diagram in figure 1. The image of the object is formed on the screen when a convex lens is placed either at A or B, if A and B are 15cm apart, find the

- i) Focal length of the lens
 - ii) Magnification of the image formed when the lens is at B
- d) Draw a ray diagram of a Galilean telescope and derive the expression for its magnifying power when in normal adjustment.

4a) i) What is meant by interference of waves?

- ii. State the conditions necessary for the observation of an interference pattern
- iii. Describe how interference can be used to test for the flatness of a surface

b) Describe with the aid of the diagram, how the wavelength of monochromatic light is measured using Young's double-slit method normally on the wedge

- i) What type of fringes will be observed?
- ii. Explain what will be observed if a liquid is introduced between the slides

d) When monochromatic light of wavelength $5.8 \times 10^{-7} m$ is incident normally on a transmission grating the second order diffraction line is observed at an angle of 27° . How many lines per centimeter does the grating have.

SECTION B

5a) i) Write down the expression for the force exerted on a straight wire of length, L meter carrying a current, I amperes at right angles to the magnetic field of flux density B tesla

(ii) A rectangular coil of N and area A m² is suspended in a uniform magnetic field of flux density B tesla. Initially the plane of the coil is at right angles to the magnetic fields .

Derive the expression for the initial couple on the coil when a current of, I amperes flow through the coil

b) Draw a labeled diagram of a moving coil galvanometer and explain how it works

c) A small circular coil of 10turns and mean radius 2.5cm is mounted at the center of a long solenoid of 750turns per meter with its axis at right angles to the axis of the solenoid. If the solenoid is 2.0A, calculate the initial torque on the circular coil when current of 1.0A is passed through it

d) Explain why a current conductor placed in magnetic field experiences a force

6a) i) what is meant by the root mean square value of an alternating current?

ii. Describe with the aid of a labeled diagram, the structure and action of a moving iron ammeter.

iii. What is meant by the term reactance?

b) In the diagram in figure 2, V_L is the voltage drop across the inductor.

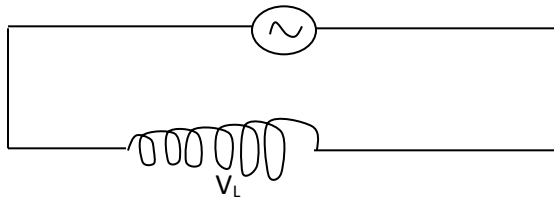

Fig. 2

i) Draw a vector diagram to show the orientation of V_L with respect to current I .

ii) Using the same axes, sketch graphs to show the variations of V_L and I with time

(c)

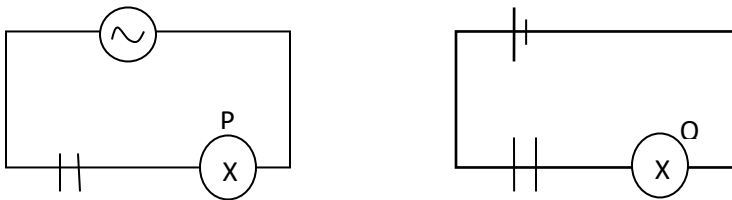

Fig. 3

The bulbs P and Q have the same rating. P is connected in series with a capacitor across an a.c. source while Q is connected in series with an identical capacitor across a d.c source of e.m.f equal to the root mean square voltage of the a.c. shown in figure 3

Explain why bulb P light continuously while bulb Q does not.

d) A 240V, 60Hz, alternating voltage is applied across a capacitor of capacitance $10\mu\text{F}$. Calculate the

i) root mean square value of the current which flows

ii) Power expended

7 a)i) Define the ampere

ii.

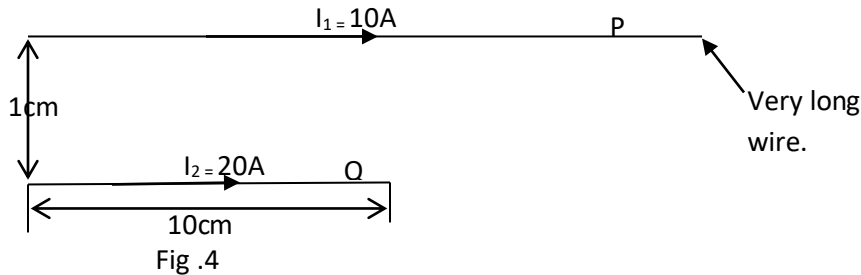

The diagram in figure 4 shows two parallel wires P and Q placed 1cm apart and carrying currents of 10A and 20A respectively in the same direction. If wire Q is 10cm long

Find the magnetic force acting on it.

b) A stream of electrons enters normally, a uniform magnetic field which is perpendicular to and directed into the plane of the page as shown in figure 5.

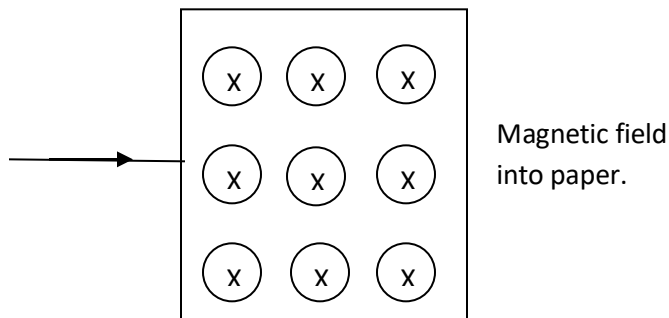

Explain with the aid of a diagram, the path of the electrons while inside the field and after leaving it.

c) Explain why, when a current is switched off in some circuits, a spark is seen across the gap of the switch

d) Show that the total charge which passes through a coil depends only on the resistance of the coil and the total flux linked.

SECTION C

- 8 a) i) Define electrical resistivity and the *ohm*
 ii) Describe an experiment to determine the electrical resistivity of a material in the form of a wire using a meter bridge.

b)

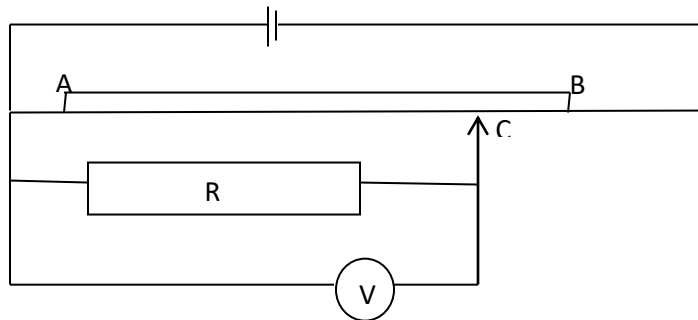

Fig.6

In figure 6 the wire AB of length 1.00m has a resistance of 10Ω . If point C is the mid-point of AB, and the voltmeter reading is 2.0V find the value of R.

- c) Describe the current versus voltage characteristics of a
 i) semi- conductor diode
 ii. Filament lamp
 d) Why does ohm's law hold at constant temperature only?
- 9 a) Define the terms dielectric constant and capacitance
 b) An air capacitor $400\mu\text{F}$ capacitor is charged to 180V and then connected across and uncharged capacitors of capacitance
 i. Find the energy stored in the $500\mu\text{F}$ capacitor
 ii. With the two capacitors still connected a dielectric of a dielectric constant 1.5 is inserted between the plates of the $400\mu\text{F}$ if the separation between the plates remains the same. Find the new p.d across the two capacitors
 c) i) State the characteristics of an equipotential surface .
 ii) Describe how a conductor can be charged at zero potential

d) Describe with the aid of a diagram, how a high voltage can be generated using a Van de Graff generator.

10a) i) State coulomb's law

ii Show that the electric flux through a spherical surface a charge in vacuum is Q/ϵ_0

b) Define the terms electric field intensity and electric potential.

c)

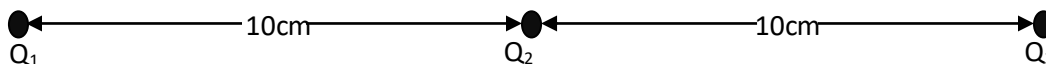

Fig. 7

Three point charges Q_1 , Q_2 and Q_3 of a magnetic $+5\mu\text{C}$, $6\mu\text{C}$, and $-20\mu\text{C}$ respectively are situated along a straight line as in figure 7

Calculate the electric field

i) intensity mid-way Q_1 and Q_2

ii) potential mid-way Q_1 and Q_2

iii) explain why two insulating bodies rubbed together acquire equal and opposite charges

iv) describe how a gold leaf electroscope can be used to verify the observation (d)(i)

Physics paper two 2002

1. a) i) State the laws of reflection light

ii) Show with the aid of ray diagram that the radius of curvature a concave mirror is twice the focal length of the mirror

b) An object is placed 20cm in front of a diverging lens placed coaxially with a concave mirror of focal length 15cm. when the concave mirror is 20cm from the lens the final image coincides with the object

i) Draw the ray diagram to show the final image is formed

ii) Determine the focal length of the diverging lens

c) i) Define angular magnification of an optical instrument

ii) What is meant by an exit pupil of a compound microscope?

iii) Describe with aid of a ray diagram, the structure and action of a compound microscope in normal adjustment

2. a) i) What is meant by the refractive index of a material?

ii) Monochromatic light incident on a block of material placed vacuum is refracted through an angle θ . If the block has a refractive index n and is of thickness t , show that the light takes a time $\frac{nt \sec \theta}{c}$ to emerge from the block where c is the speed of light in a vacuum

(b)

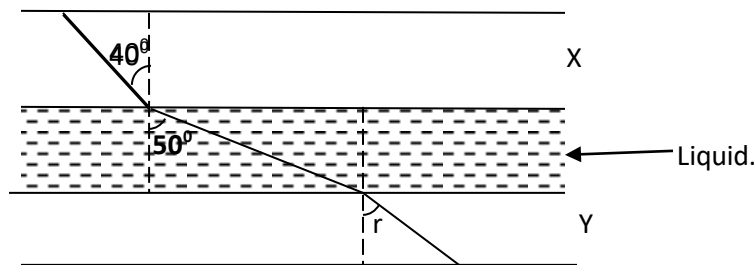

Figure 1 shows a layer of liquid confined between two transparent plates X and Y of refractive indices 1.54 and 1.44, respectively.

A ray mono-chromatic light making an angle of 40° with the normal to the interface between medium X and the liquid is refracted through an angle of 50° by the liquid. Find the

- Refractive index of the liquid
- Angle of refraction, r in the medium Y
- Minimum angle of incidence in medium X for which the light will not emerge from medium Y

c) i) A ray monochromatic light is incident at a small angle of incidence on a small angle prism in air. Obtain the expression $d = (n-1)A$ for deviation of the angle by the prism

ii) Light of two wavelengths is incident at a small angle on a thin prism of refracting angles 5° and refractive indices 1.52 and 1.50 for the two wavelengths. Find the angular separation of the two wavelengths after refraction by the prism

3. a) Why is light referred to as transverse wave?

b) i) State Huygens's principle

ii) Use Huygens's principle to show that the refractive index of medium 2 relative to medium 1 is given by

$$n_2 = \frac{v_1}{v_2} \text{ where } v_1 \text{ and } v_2 \text{ are the velocities of light in medium 1 and 2 respectively}$$

- c) i) What is meant by division of wave fronts as applied to interference of wave?
 ii) Two slits A and B are separated by a distance d and illuminated with light of wavelength λ . Derive the expression for the separation between successive fringes on a screen placed a distance D from the slits.
 iii) . In Young's double slit experiment, the 8th bright fringe is formed 5mm away from the center of the fringe system when the wavelength of light used is $6.5 \times 10^{-7}m$. calculate the separation to the two slit if the distance from the slits to the screen is 80cm.
- 4 a) Explain the term interference as applied to light.

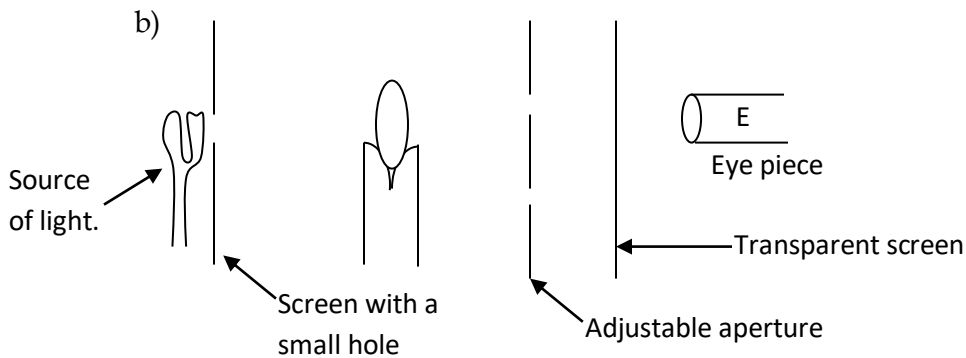

Fig.2

In an experience to observe diffraction of light, the set up in figure 2is used

- i) Describe what you would see at E if the aperture is gradually reduced
 - ii) Explain your observations in (b)(i) above
- c) A diffraction grating has 550 lines per mm. when it is illuminated normally by monochromatic light, the angle between the central maximum and first maximum is 19.1° . Find the
- i) Wavelength of the light
 - ii) Number of diffraction maxima obtainable
- d) State two uses of light

SECTION B

- 5 a) Distinguish between self induction and mutual induction
- b) i) Explain the factors which affect the efficiency of a transformer

ii) Power of 6000W produced at 100V is to be transmitted over distance of 2km through cables of resistance $0.2\Omega m^{-1}$. determine the voltage at the output of a transformer needed to transmit the power so that only 5% of it is lost (Assume the transformer is 100% efficient.)

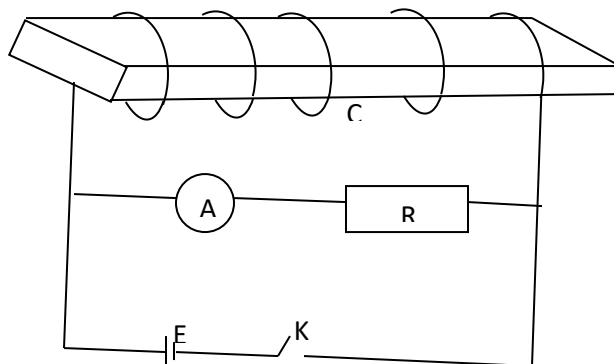

Fig 3.

In the diagram in figure 3, C is a coil of a large number of turn connected in series with a center Zero meter had A, and a resistor R across cell E. the switch k is closed for some time and then opened

- i) Sketch a graph to show the variation of current with time observed on the ammeter from the moment K was first closed
 - ii) Explain the variation of current observe (c)(i)
 - iii) Describe the effect of placing a bunch of soft iron wires inside the coil, on the observations in (c)(i) and (c)(ii)
- 6a) i) Write down the expression for the force on a charge, q coulombs moving with velocity, V at an angle, θ to a uniform magnetic field of flux density, B
- ii Use the expression in (a)(i) above to deduce the force on a conductor carrying a current in a magnetic field
 - iii two thin, long parallel wires A and B currents of 5A and 2A respectively in opposite direction. If the wire is separated by a distance of 2.5cm in a vacuum, calculate the force exerted by wire B on 1m of wire A

- b) With the aid of a diagram, explain the terms angle of dip and magnetic meridian, as applied to the earth's magnetic field
- c) i) Describe, using an appropriate circuit diagram, an experiment to investigate the dependence of magnetic flux density at the center of a circular coil, on the current through the coil
- ii. State two other factors on which the magnetic flux density in (c)(i) depends

7. a) i) Define magnetic flux

- ii. Describe an experiment to investigate the relation between the force on a current conductor situated in a uniform magnetic field and the current, using the ampere/current balance

b)

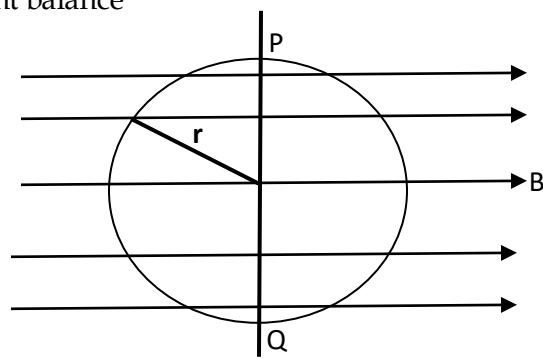

Fig. 4

\A circular loop of wire radius r is placed in a uniform magnetic field of flux density B , with the axis to the field as shown in figure 4.

Explain what happens to the loop when starts to flow in it in a clockwise direction if the loop is pivoted about the axis POQ

- c) A vertical square coil of side 5cm has 100turns and carries a current of 1A. Calculate the torque on the coil when it is placed in a horizontal magnetic field of flux density 0.2T with its plane making an angle of 30° to the field
- d) Explain why a moving coil galvanometer should have a radial magnetic field, fine hair spring and many turns

8a) State *ohm's law*

- b) Describe with the aid of a circuit diagram, an experiment to determine the relationship between the resistance and the length of the wire

c) A dry cell gives a balance length of 84.8 cm on a potentiometer wire. When a resistor of resistance 15Ω is connected a cross the terminals. Find the internal resistance of the cell

- d) A battery of e.m.f 18.0 V and internal resistance 3.0Ω . Calculate the
- Power generated
 - Efficiency
- e) If the 8Ω resistor in (d) is placed by a variable resistor. Sketch graphs to show the variation of power and efficiency with the load
- f) Explain why a metal wire hot when current is passed through it

9. a) Define electric potential

b) Obtain an expression for the electric potential at a point a distance, r from a point charge, Q , situated in vacuum

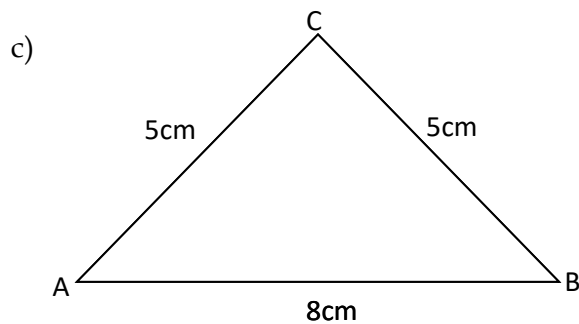

Figure 5

Two point charge A and B charges $+0.10\mu\text{C}$ and $0.05\mu\text{C}$ are separated by a distance of 8.0cm along the horizontal as shown in figure5. Find the electric field intensity at p

d) Sketch the electric field pattern due to the charge distribution in (c) above

e) Explain how a lightning conductor works.

10 a) Sketch the electric field lines between two large parallel metal plates across which a p.d is applied

b) i) Describe with aid of a diagram, how you would investigate the factor which affect the capacitance of a parallel plate capacitor

ii) Calculate the capacitance of a parallel capacitor whose plates are 10cm by 10cm separated by an air gap of 5mm.

c) Show that the effective conductor of diameter 21.4cm carrying a charge of $6.9 \times 10^{-10}\text{C}$ is raised to a potential of 50V find the permittivity of surrounding medium

d) i) Show that the effective capacitance, C , of two capacitances, C_1 and C_2 connected in series is given by

$$C = \frac{C_1 C_2}{C_1 + C_2}$$

- ii A $20\mu\text{F}$ capacitor is charged to 40V and then connected across an uncharged $60\mu\text{F}$ capacitor. Calculate the potential difference across the $60\mu\text{F}$.

Physics paper two 2001

- a) State the laws of refraction of light
- b) i) Derive an expression for the refractive index of a prism in terms of the refracting angle, A , and the angle of minimum deviation, D
- iii) Monochromatic light is incident on one refracting face of a prism of refracting angle 60° , made of glass of refraction 1.50
Calculate the least angle for the ray to emerge through the second refracting face
- c) i) State three differences between a compound microscope and a telescope
ii Describe, with the aid of a diagram, how a compound microscope forms a final image at the near point
2. a) Define the terms radius of curvature and focal length of a converging mirror.
- b) i) Draw a ray diagram to show the formation of a real image of a real object by a converging mirror.
ii) Use the ray diagram in (b)(i) to derive the expression $\frac{1}{f} = \frac{1}{v} + \frac{1}{u}$, where u , v , and f are the object distance
- c) i) With the aid of a ray diagram, describe the structure and action of a reflecting telescope over an astronomical telescope.
- d) An astronomical telescope has an objective of focal length 100cm and an eyepiece of focal length 10cm
- e) Calculate the separation of the objective and eyepiece if the lenses are arranged in such a way that the final image is formed at 25cm from the eye.

3a) i) Distinguish between free and damped oscillations.

ii) Describe how the amplitude of a forced oscillation builds up to a constant value

B) The displacement in meters of a plane progressive wave is given by the equation

$$y = 0.2 \sin\left[200t - \frac{20x}{17}\right]$$

Find

- i. Wavelength and
- ii. Speed, of the wave

c) Explain the occurrence of beats in sound

ii Two tuning forks X and Y are sounded together to produce beats of frequency 8HZ.

Fork X has a known frequency of 512HZ

When Y is loaded with small plasticize, beats at a frequency of 2HZ are heard when two tuning forks are sounded together.

Calculate the frequency of Y when unloaded

d) i) What is meant by Doppler Effect?

ii A car sounds its horn as it travels at a steady speed of 15ms^{-1} along a straight road between two stationary observers A and B. The observer A hears a frequency of 538HZ while B hears a lower frequency

Calculate the frequency heard by B, assuming the speed of sound in the air 340ms^{-1}

3. a) i) What is meant by interference and diffraction of light waves?

ii State the condition necessary for observing diffraction

b) i) Derive the expression for the fringe separation in Young's interference pattern in terms of the slit-separation, d , the distance, D , of the screen from double slit and the wavelength λ of the light

c) Two slits 0.50mm apart is placed at a distance of 1.0m from the screen. The slits are illuminated with light of wavelength 550nm.

Calculate the distance between the fourth and second bright fringes of the interference pattern.

- d) A transmission diffraction grating of spacing, d is illuminated normally with light of wave length λ
- Derive the condition for occurrence of diffraction on a screen placed beyond the grating
 - What is the effect on the diffraction pattern of using a grating with a larger number of lines?

SECTION B

- Define the ampere
 - Write down the expression for the force on a conductor carrying which is inclined at an angle θ to a uniform magnetic field
- b)

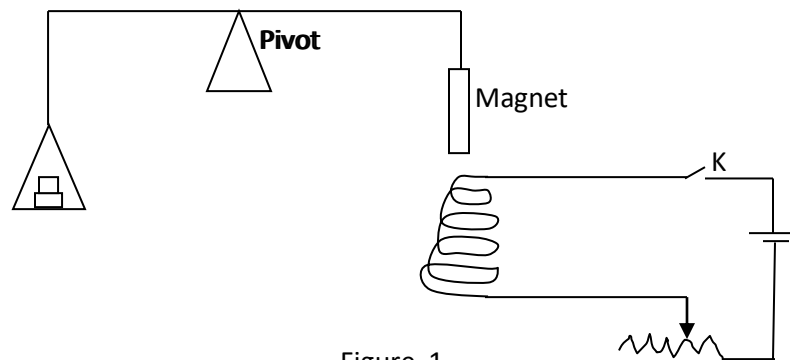

Figure. 1

Figure 1 represents a current balance. When switch, K is open the force required to balance the magnet is 0.2N . When switch, K is closed and a current of 0.5A flows is required for balance.

- Determine the polarity at the end of the magnet closest to the coil
 - Calculate the weight required for the balance when a current 2A flows through the coil.
- c) A rectangular coil N turns of dimensions $l \times b$ is inclined at an angle θ to a uniform magnetic field of flux density, B .
- Derive an expression for the torque on the coil if a current, I is passed through it

- d. A ballistic galvanometer of sensitivity of the coil per μC is connected across a coil of 10 turns would tightly round the middle of a solenoid of 10^3 turns per meter and diameter 5.0cm. When the current in the solenoid is reversed, the ballistic galvanometer deflects through 8 divisions. If the total resistance of the coil and galvanometer is 20Ω , find the current in the coil.
- 6 a) State the laws of electro-magnetic induction
- b) A circular coil of 100turns and cross-sectional area 0.2m^2 is placed with its plane perpendicular to a horizontal magnetic field of flux density $1.0 \times 10^{-2}\text{ T}$
The coil is rotated about a vertical axis so that it turns through 60° in 2s
- i) the initial flux linkage through the coil
- ii) the e.m.f induced in the coil
- c) i) Explain the origin of the back e.m.f in an electric motor
- ii) A motor whose armature resistance is 2Ω is operated on 240V mains supply. If the back e.m.f in the motor is 220V. Calculate the armature current
- d. i) describe with the aid of a diagram the mode of action of a simple d.c generator.
- ii. Sketch the output of a d. c generator
- iii) What is the major different between a d.c motor and a d.c generator
7. a) Define root mean square value (rms) of an alternating current
- b) A sinusoidal alternating voltage $V=170 \sin 120\pi t$, volts, is applied across a resistor of resistance. 100Ω

Determine

- i) the rms value of the current which flows
- ii) the frequency of the current through the resistor.
- c) With the aid of a labeled diagram describe the structure and action of a hot wire ammeter
- d) Explain the terms self-induction and mutual induction
- e) A coil of self-inductance L and negligible resistance is connected across a source of alternating voltage $V=V_0 \cos \omega t$
- i) Find the expression for the current which flows in the coil
- ii) Sketch, using the same axes, the time variation of the applied voltage and the current which flows in the coil

SECTION C

8. a) Derive the condition for a wheat stone bridge to be balanced
- b) i) Define temperature coefficient of resistance
- ii) When a coil X connected across the left-hand gap of a meter bridge is heated to a temperature of 30°C , the balance point is found to be 51.5cm from the left-hand end of the slide wire. When the temperature is raised to 100°C the balance point is 54.6cm from the left end. Find the temperature coefficient resistance of X
- c) i) A battery of e.m.f ϵ and internal resistance, r is connected to a resistor of variable resistance, R Obtain the expression for maximum power dissipated in the resistor
- ii) A battery of e.m.f 6V and internal resistance of 1Ω is connected across a network of resistors as shown in figure 2
- Find the current supplied by the battery

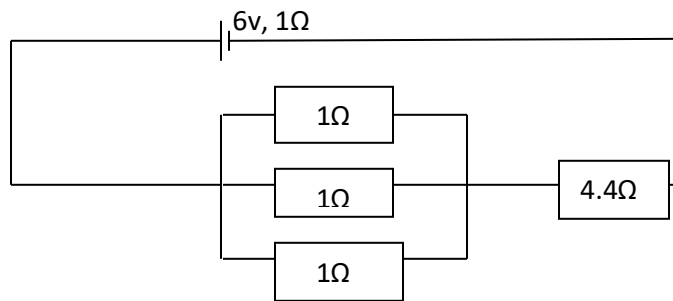

Figure 21

9. a) State coulomb's law of electrostatics
- b) Define electric field intensity and electric potential
- ii) Two identical conducting balls of mass, m are each suspended in air a silk thread of length, l . when the two ball are each given charge, q , they move apart as shown in figure 3.

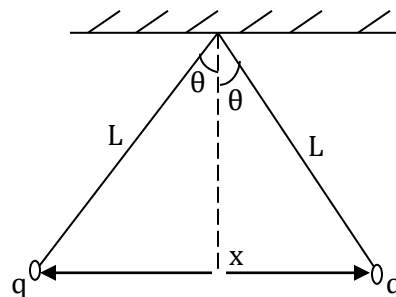

Figure 3.

If at equilibrium each thread makes a small angle θ with the vertical, show that the separation is given by

$$x = \left[\frac{q^2 l}{2\pi\epsilon m g} \right]^{1/3} \text{ where } \epsilon \text{ is permittivity of air}$$

- c) i) Define the term capacitance of a capacitor
 ii) State the factors that affect the capacitance of a capacitor
 iii) show that the energy stored in a capacitor of capacitance, C charged to a p.d V is equal to $\frac{1}{2} CV^2$
- d) The plates of a parallel plate capacitor each of area 2.0cm^2 are 5mm apart. The plate is in vacuum and potential difference of 10,000V is applied across the capacitor. Find the magnitude of the charge on the capacitor.
10. a) Define temperature coefficient of resistance and electrical resistivity
 b) A nichrome wire of length 1.0m and diameter 0.72mm at 25°C is made into a coil. The coil is immersed in 200cm^3 of water at the same temperature and a current of 5.0A is passed through the coil for 8 minutes until when the water starts to boil at 100°C
 Find
 i. the resistance of the coil at 25°C
 ii. The electrical energy expended assuming all of it goes into heating the water.
 iii. The mean temperature coefficient of resistance of nichrome between 0°C and 100°C
- c) Describe, with the aid of a circuit diagram, how a slide wire potentiometer can be used to measure e.m.f of a cell.
- d) An accumulator of e.m.f 2.0V. is connected across a uniform wire of length 1.0m and resistance 8.0Ω . A cell of e.m.f 1.50V is connected in series with a galvanometer shows no deflection a length, l of the slide wire. A galvanometer shows no deflection when l is 90.0cm
 Find the internal resistance of the accumulator.

Physics paper two 2000

- 1 a) Define principal focus of a converging lens

- b) A converging lens of focal length f is placed between a finite object and a screen. The position of the screen is adjusted until a clear magnified image is obtained on the screen. Keeping the screen a distance d to obtain a clear diminished image on the screen.
- i) Draw a ray diagram to show the formation of the images in the two cases.
- ii) Show that $l^2 - d^2 = 4df$
- iii Find the product of the magnifying produced in the two cases
- c) i) Draw a ray diagram to show how two converging lenses, one of long focal length, f_1 and the other of shorter length, f_2 can be arranged to make an astronomical telescope in normal adjustment
- ii) Derive the expression for the magnifying power of the telescope in this setting
- d. The objective of a compound microscope has a focal length of 2.0cm while the eye piece has a focal of 50cm. an object is placed at a distance of the eye piece from the objective is adjusted so that the final image is 25cm in front of the eyepiece. Find the distance between the objective and eyepiece

2a) i) What is meant by refraction of light?

ii State the laws of refraction

b) Describe how the refractive index of a material of a glass prism of known refracting angle can be determined using a spectrometer

c)

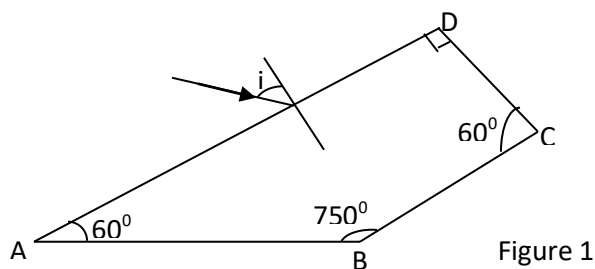

A ray of light is incident on the face AD of a glass block as shown in figure 1. The refractive index of the material of the glass block is 1.52. if the ray emerge normally through face BC after total internal reflection, calculate the angle of incident, i

d. Explain how a image is formed

e) An object at a depth of 3.0m below the surface of water is observed directly from above the surface. Calculate the apparent displacement of the object if the refractive index is 1.33.

- 3a) State the principle of superposition of waves
- b) Two loud speakers producing sound of the same frequency are placed 50m apart facing each other. An observer walks from one speaker to the other along the line of the speakers.
- What does the observer hear?
 - Explain the observer in (b)(i)
- c) Describe with the aid of a diagram how you can determine the velocity of sound in air by a method uses interference of sound
- d) A progressive and stationary wave each has a frequency of 240Hz and a speed 80ms^{-1} calculate
- Phase different between two vibrating points in the progressive waves which are 6cm apart
 - Distance between nodes in the stationary wave.
- 4a) what is meant by coherent sources of light?
- b) i) Outline the principle of Young's double interference and derive the expression for the fringe separation
- ii) What would be the effect of replacing monochromatic light by white in Young's double slit experiment?
- c) An air wedge is formed by replacing two glass slides of length 5.0cm in contact at one end and wire at the other end as shown in figure 2

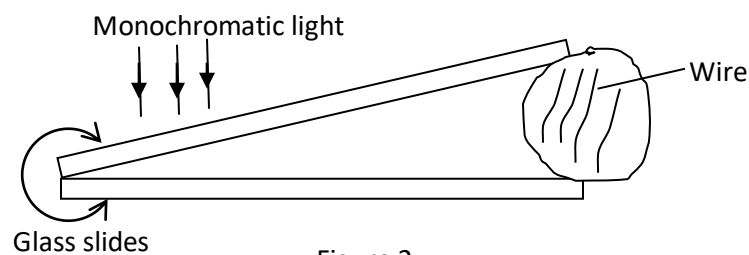

Viewing from vertically above 10 dark fringes are observed to occupy a distance of 2.5mm when the slides are illuminated with light of wavelength 500nm

- Explain briefly how the fringes are formed
- Determine the diameter of the wire

SECTION B

- 5a) Write down expression for the magnetic flux density at

- i) A perpendicular distance, d , from along straight wire carrying a current, I in a vacuum
 - ii) The center of a circular coil of N turns each radius, R and carrying a current I
 - iii) The center of an air-cored solenoid of n turns per meter each carrying current I
- b) Sketch the magnetic field pattern around a vertical current carrying straight wire in the earth's magnetic and used it to explain a neutral in magnetic field.
- c) What is meant by the terms?
- i. magnetic meridian?
 - ii. Angle of dip?
- d) . A circular coil of 10 turns and diameter 12cm carries current i . the coil is placed with its plane in the magnetic meridian. A small magnetic needle placed at the center of the coil makes 30 oscillations per minute about a vertical axis when the current is cut off; it makes 15 oscillations per minute. If the horizontal component of the earth's magnetic flux density is $2.0 \times 10^{-5} \text{T}$, calculate the magnetic of I (Assume that the square of frequency of oscillation is proportional to the magnetic flux density)
- e. Explain what is meant by eddy currents and give four of their applications
- 6a) State the laws of electromagnetic induction
- b) i) With the aid of a labeled diagram, describe the structure and mode of action of an a.c transformer
 - ii) What are the main energy losses in a transformer and how are they minimized?
- c) An a.c transformer operates on a 240V mains. The voltage across the secondary which has 960 turns is 20V
- i) Find the number of turns in the primary
 - ii) If the efficiency of the transformer is 80%, calculate the current in the primary coil when a resistor of 40Ω is connected across the secondary
- d. Two long parallel wire X and Y are separated by 8cm in a vacuum
The wires carry currents of 10A and 5A respectively in the same direction.
At what points between the wires in the magnetic flux density zero?
- 7a) define the terms amplitude and root mean square (r.m.s) value of an alternating current

- b) A sinusoidal alternating current $I = 4\sin(100\pi t)$ amperes flows through a resistor. Hence deduce the r.m.s value of the current.
- c) Describe with the aid of a labeled diagram, how a hot wire ammeter works
- d) An inductor of inductance L is connected across a source of altering voltage $V = V_0 \sin \omega t$
- Find the current which flows
 - Sketch, using the same axes, the variation through it, and explain the phase difference between them.

SECTION C

8a) Distinguish between *e.m.f* and terminal *p.d* of a battery

- Define electrical resistivity
 - Explain any two factors on which the resistance of a conductor depends
- c) Two wires A and B have lengths which are in the ratio 4:5 diameter which are in the ratio 2:1 and resistances in the ratio of 3:2. If the wires are arranged in parallel and current of 1.0A flow through the combination, find the
- Ratio of resistance of wire A to that of wire B
 - Current through wire A

9a) State Ohm's law

- State the factors which affect the resistance of a conductor
- A conductor of length l and across sectional area A has n free electrons per unit volume each of charge e . Find the drift velocity, v , of these electrons if a current flow through the conductor

b) Outline the principle of operation of a slide wire potentiometer

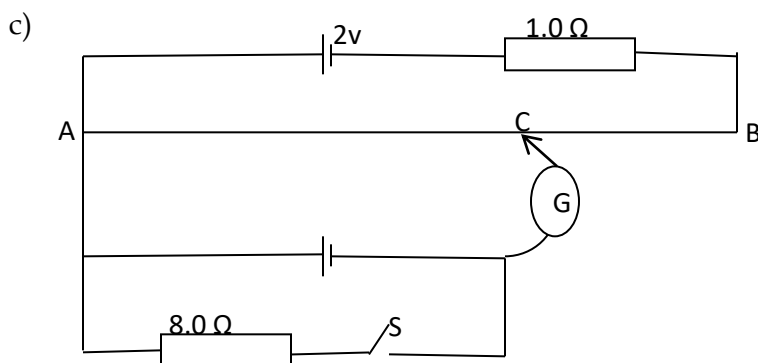

Figure 3

In the figure 3 the slide wire AB is 1m long and has a resistance on 4Ω when switch S is

- i) Open the balance length AC is 88.8cm. find the value of the e.m.f of the cell
 - ii) Closed, the balance length is found to be 82.5cm calculate the internal resistance of this cell
- d. State two advantages of using a potentiometer for measuring voltage
- 10a) what is a dielectric material?
- b) A capacitor filled with a dielectric is charged and then discharged through a millimeter again; show that the relative permittivity, ϵ_r , of the dielectric is given by $\epsilon_r = \frac{I}{2I^1 - I}$ where I and I^1 are the readings of the millimeter respectively
- c) Describe with the aid of a diagram how you would determine the capacitance of a capacitor.

d)

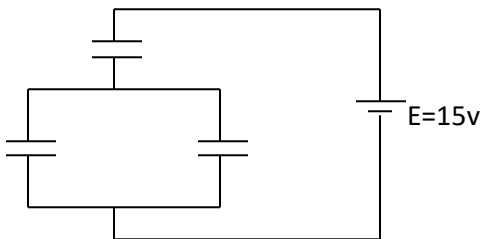

Figure 4.

A battery e.m.f. 15V is connected across a system of capacitors as shown in figure 4 find the Charge in the $4\mu\text{F}$ system of capacitors as shown in figure 4 find the

- i) Charge in the $4\mu\text{F}$ capacitor
- ii) Energy stored in the $3\mu\text{F}$ capacitor

Physics paper two 1999

1. a) Define refraction
 - b) i) With the aid of the suitable ray diagrams explain the terms critical angle and total internal reflection
 - ii) Monochromatic light is incident at an angle of 45° on a glass prism refracting angle 70° in air. The emergent light grazes the other refracting surface of the prism. Find the refractive index of the glass.

- c) i) With the aid of a labeled diagram describe the structure and action of prism binoculars
- ii) Explain why prisms rather than plane mirrors are used in binoculars
- iii) In a pair of prisms binoculars the optical path from the objective to the eye-piece is 50.0cm. The eye-piece has a focal length of 2.5cm. find the magnifying power in normal adjustment
2. a) Describe how the focal length of a diverging lens may be determined
- b) A lens L_1 casts a real image of a distant object on a screen placed at a distance 15cm away. When another lens L_2 is placed 5cm beyond lens L_1 the screen has to be shifted by 10cm further way to locate the real image formed.
Determine the focal length and the type of lens L_2
- c) A convex lens of focal length 60cm is arranged co-axially
With a diverging lens to focal length 5cm, to view a distance star
- i) If the final image is at infinity, draw a ray diagram to show the formation of the image of the star.
- ii) Calculate the magnifying power obtained if the image of the star is formed at a distance of 25cm in front of the eye piece
- iii) List one advantage and one disadvantage of this type of arrangement over the astronomical telescope.
3. a)i) What is meant by coherent source of waves?
- ii) Distinguish between interference and diffraction of light
Give one example of each
- b) With the aid of suitable sketches, explain the following
- i. division of waves front
- ii) Division of amplitude
- c) Monochrome light of wave length 5×10^{-7} m is incident on two slits of separation 4×10^{-3} m. calculate the fringe separation on a screen place 1.5m form the slits.
- d) A car travelling at 72kmh^{-1} has a siren which produced sound of frequency 500Hz.
Calculate the difference between the frequency of sound heard by an observer by the roadside as the car approaches and recedes from the observer (speed of sound in air= 320ms^{-1})

4. a) What is meant by the term free, damped and forced oscillations
- b) The displacement of a progressive wave is $y = [2 \sin(2\pi(0.25 \times -100ms^{-1}))]$ where x and y are in cm and t is in seconds. Calculate the:
- wave length
 - velocity of propagation
- Of the wave
- c) i) Explain how beats are produced
- An observer moving between two stationary sources of sound along a straight line joining them hears beats at the rate of $4.0s^{-1}$. At what velocity is the observer moving if the frequencies of the sources are 500Hz and the velocity of sound when the observer makes the observation is $340ms^{-1}$?

SECTION B

5. a) Explain the following terms as applied to the Earth's magnetic field
- wave length ,
 - angle of dip
 - declination
- b) Draw sketch diagrams to show the magnetic field pattern due to an electric current flowing through a circular coil and a long solenoid
- c) A circular coil of 20 turns each of radius 10.0cm lies flat on a table. The Earth's magnetic field intensity at the location of the coil is $43.8Am^{-1}$ while the angle of dip is 67.0° . Find the
- Magnetic flux threading the coil
 - Torque on the coil of 2.0A is placed through it.
- d. If you are given a coil of known number of turns N , known are A and known resistance box, a compass needle and a calibrated ballistic galvanometer, describe briefly how you would determine the horizontal component of the earth's magnetic flux density
6. a) What is meant by the following terms
- Self induction?
 - Mutual induction
- b) Two coils X and Y are placed coaxially near other as shown in figure

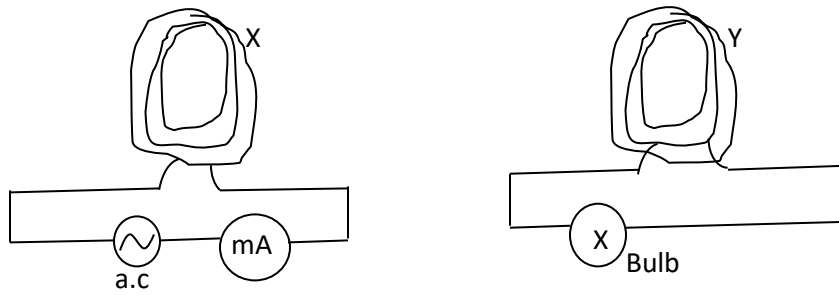

Fig.1

Explain the following observation:

- i. When the a.c supply is switched on the bulb lights up
- ii. The brightness of the bulb increases when a soft iron rod is placed inside and along the common axis of the coils
- iii. The brightness of the bulb varies with distance between the coils

c) An air-cored long solenoid of 500 circular turns per meter and radius 8.0cm has a secondary coil of 20 turns tight wound round its middle. The current in the solenoid is 2.0A. Find the e.m.f induced in the coil when the current in the solenoid is reduced in 10^{-2} s.

d) With the aid of a circuit diagram, describe the mode of action of a full-wave rectifier.

7. a) i) With the aid of a labeled diagram describe the structure and mode of operation of an a.c generator.

iii. Sketch a graph of the output voltage against time

b) A flat circular coil with 500 turns each of radius 10cm is rotated at a frequency of 200 revolutions per minute about its diameter at right angles to a uniform magnetic field of flux density 0.18T. Calculate the

- i. maximum magnetic linking the coil
- ii) E.m.f induced in the coil when the plane of the coil makes an angle of 30° with the magnetic field

iii) Root mean square value of the e.m.f induced in the coil

c) i) State any three factors which limit the efficiency of a transformer and indicate how they are minimized in practice

ii) Show that the power loss, P_l in a transmission line of total resistance R_l , is given by.

$$P_l = \frac{v_r^2 R_l}{v^2}, \text{ where } P_l \text{ and } V \text{ are the power transmitted and the}$$

voltage delivered to the user, respectively

SECTION C

8. a) What is meant by the e.m.f and internal resistance of a battery?
- b) A d.c of e.m.f 16V and negligible internal resistance is connected in series with two resistors of 400 and R ohms, respectively. When a voltmeter is connected across the 400Ω resistor, it reads 4.0V while it reads 6.0V when connected across the resistor of R ohms find the
- resistor of the voltmeter
 - Value of R
- c) Describe how you would use a slide wire potentiometer to measure the internal resistance of a dry cell
- d) In the figure 2 AB is a uniform resistance wire of length 1.00m and resistance 10.0. E is an accumulator of e.m.f 2.0V and internal resistance 1.0Ω.

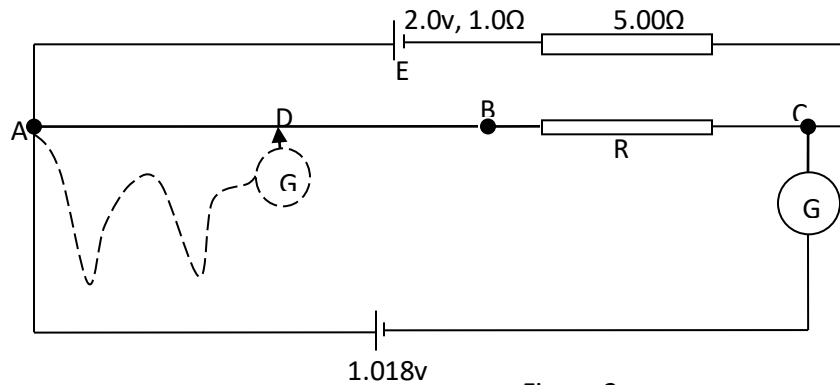
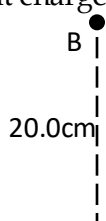

Figure 2

When a standard cell of e.m.f 1.018V is connected in series with a galvanometer, G across AC, the galvanometer shows no deflection. When the standard cell is removed and a thermocouple connected via the galvanometer G, as shown by the dotted line, G shows no deflection when AD= 41.0cm

Calculate the

- value of R
 - e.m.f of the thermocouple
9. a) Define electric potential and electric field intensity
- b) Consider two points A and B at distance of 1.50cm and 20.0cm respectively from a point charge of 6.0μC as shown in figure 3.



- i) find the electric potential difference between A and B
 - ii) Calculate the energy required to bring a charge of $+1.0\mu\text{C}$ from infinity to point A.
- c) Alpha particle (charge $=+2e$) each having kinetic energy $1.0 \times 10^{-12}\text{J}$ are incident head-on gold nuclei (charge $=+79$) in a gold foil. Calculate the distance of closest approach of an α - particle to a gold nucleus [$e = 1.6 \times 10^{-9}\text{C}$]
- d) Describe an experiment to show that charge resides only on the outside surface of a hollow conductor.
10. a) Describe and account for the difference between the structures of a moving coil galvanometer and the ballistic form of the instrument.
- b) With the aid of a circuit diagram, describe how you would compare capacitances of two capacitors using a ballistic galvanometer.
- c) Two large opposite charged plates are fixed 1.0cm apart as shown in figure 4. The p.d between the plates is 50V .

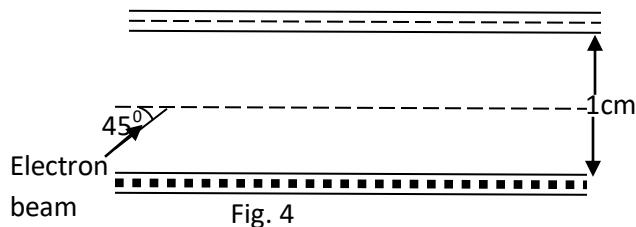

An electron beam enters the region in between the plates at an angle of 45° as shown. Find the maximum speed the electrons must have in order for them not to strike the upper plate

[Mass of an electron $= 9.11 \times 10^{-31}\text{kg}$]

- d) Describe the energy changes which occur when a capacitor is being charged from a battery.

Physics paper two 1998

1. a) i) State the laws of refraction of light

ii) Show that the relation between refraction index, n and critical angle, c for a ray of light travelling to air is given by

$$n = \frac{1}{\sin c}$$

b) Describe with the aid of a diagram how the refractive index of a transparent liquid may be determined

c) Explain how light from the sun reaches an observer in the morning before the sun appears above the horizon.

d)

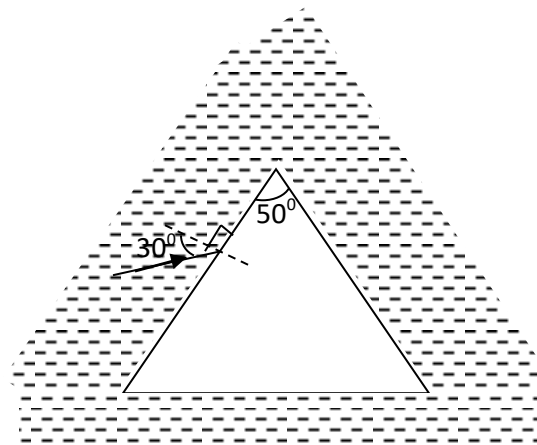

i. A ray of light propagating in a liquid is incident on a prism of refracting angle 50° and refractive index of 1.6 at an angle of 30° as shown in figure 1. If the ray passes symmetrically through the prism, find the refractive index of the liquid.

ii. Explain why white light dispersed by a transparent medium

2. a) i. Define focal length of a lens

ii. A convex lens is contained in a cylindrical tube such that its exact position in the tube is not accessible

Describe how you would determine the focal length of the lens without removing the lens from the tube. Derive the formula used to obtain the final result

b) i. Derive angular magnifications of an optical instrument

ii. Explain why the farthest vertical pole in line with others of equal height looks shorter

c) With the help of a labeled diagram describe how a slide projector works.

- d) A projector projects an image of area 1m^2 onto a screen placed 5m from the projection lens. If the area of the object slide is 4cm^2
- focal length of the projection lens
 - Distance of the slide from the lens
- a) Define the term amplitude, frequency and wavelength as applied to wave motion
- Derive the relationship between velocity, wavelength and frequency of a wave
- b) A plane progressive wave is given by
- $$y = a \sin(100\pi t - \frac{10\pi x}{9}),$$
- Where x and y are millimeters and t is in seconds
- Write the equation of the progressive wave would give rise to a stationary wave if superimposed on the above
 - Find the equation of the stationary wave and hence determine its amplitude of vibration
 - Determine the frequency and velocity of the determined using its amplitude of vibration
- c) Describe how the velocity of sound in air may be determined using a resonance tube and tuning forks of known frequencies
- a) State the conditions necessary for the production of interface effects with light and explain why these conditions are necessary.
- b) i. Describe with the aid of a labeled diagram the experimental set up for observing Newton's rings
- explain qualitatively how Newton's ring is formed
- c) two glass plates 12.0cm long are in contact at one edge and separated at the other edge by a piece of metal foil $2.5 \times 10^{-3}\text{cm}$ thick. When the plates are illuminated as shown in figure 2, by light of wavelength 500nm , a system of fringes is formed.

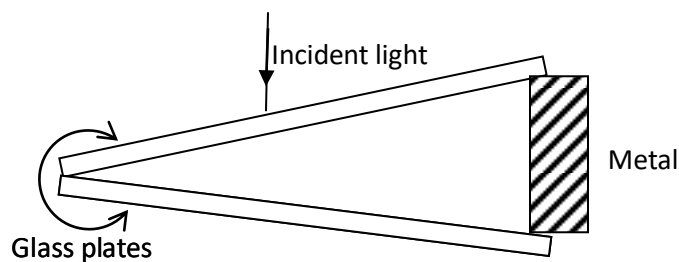
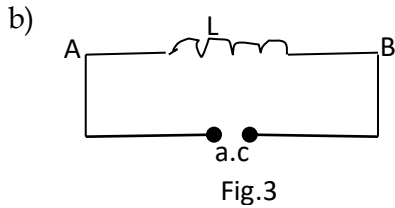

Fig.2

Find the

- separation of the fringes

- ii. number of dark fringes formed
- 5. a) i) Distinguish between root mean square value and peak value of an alternating current
- ii. What is the peak value of the voltage from 240V ac mains?
- iii. What is meant by self- induction?



A coil of inductance L is connected to a source of alternating current as shown in figure 3 if the current in the coil is given by

$$I = I_0 \sin \omega t$$

- ii. Sketch, using the same axes, graph to show variation of V and I with time and comment on the graphs.
- d) i. Explain why a capacitor allows the flow of alternating current but not of direct current yet it conducts direct current
- e) i) With the aid of a diagram describe how a repulsion type of moving iron meter works
- ii. state two advantages of a moving iron meter over a moving coil one
- 6. a) State the laws of electromagnetic induction.

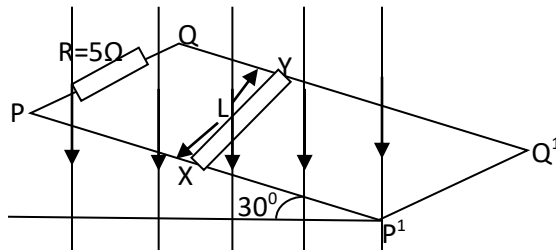

Fig.4

A metal rod XY of mass 0.2kg , length, 0.8m and negligible resistance rolls down frictionless metal rails pp' and QQ , inclined at 30° to the horizontal. The rails in a uniform vertical magnetic field of flux density 0.4 T . the end PQ of the rails are connected to a resistance of 5Ω a shown in figure 4. Calculate the constant speed the rod attains.

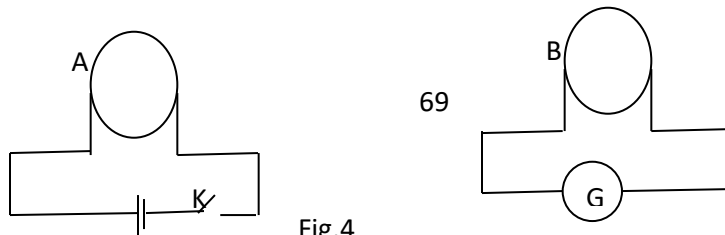

Fig.4

b)

- i. Two coils A and B are placed close to each other with their planes parallel. A is connected in series with a cell and switch K B is connected in series with a galvanometer, G as shown in =figure % explain what is observed when K is momentarily closed
- ii. Explain how the observation in (c)(i) above would be affected if a branch of soft wires rather than a solid iron bar is placed inside the coils.

d)

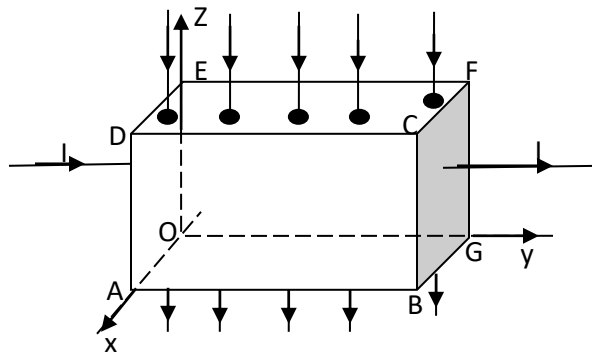

Figure 6

In the diagram above OABCDEFG is rectangular conductor carrying current in the direction OY. The conductor is situated in uniform magnetic field which is perpendicular to the face CDEF as shown in figure 6

Explain why there is a p.d between faces ABCD and OEFG

7. a) i) Define the term magnetic flux density and state its units
 - ii) Describe the construction and working of a moving coil galvanometer
- b) A capacitor of capacitance $2000\mu\text{F}$ is fully charged to 10 V . when the capacitor is discharged through a ballistic galvanometer, the galvanometer gives maximum throw of 20 divisions. A coil of 25 turns, each of radius 10cm is placed with its plane perpendicular to a uniform magnetic field. The coil is connected in series with the ballistic galvanometer. When the coil is rotated through 180° , the galvanometer gives a maximum throw of 15 divisions. Calculate the magnetic flux density, if the total resistance in the circuit is 3Ω

c). Describe, using a labeled diagram the main characteristics of the Earth's magnetic field

SECTION C

8. a) i) Define electrical resistivity

ii) State the law of conservation of current at a junction in an electrical circuit?

b) A battery of e.m.f ϵ and internal resistance, r , connected across a resistor of variable resistance, R , derive the expression for the maximum power expended in the resistor

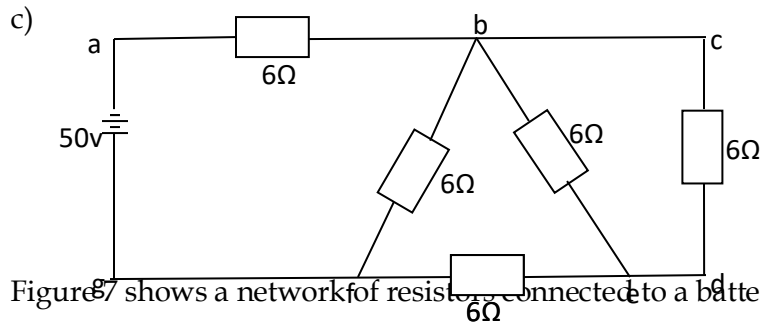

Figure 7 shows a network of resistors connected to a battery of e.m.f. 50V and internal resistance 0.4Ω . Calculate the

i. effective resistance in the circuit

ii. power dissipated in the battery

d) Describe with the aid of a circuit diagram how the emf s of two cells can be compared using a potentiometer slide wire.

9. a) i) State Coulomb's law of electrostatics

ii. The electric intensive at the surface of the earth is about $1.2 \times 10^2 \text{Vm}^{-1}$ and points towards the center of the earth assuming that the earth is sphere of radius $6.4 \times 10^6 \text{m}$, Find the charge held by the earth's surface.

iii. Two points charge $+4.0\mu\text{C}$ are separated by 10.0 cm in air as shown in figure 8.

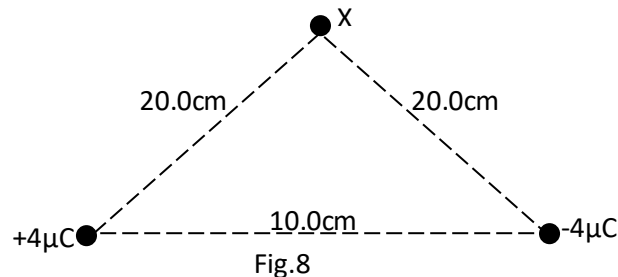

Find the electric field intensity at point x a distance of 20.0cm from the charge

c) i) What is meant by corona discharge?

ii) Explain how the lightning conductor works

- a) What is meant by
- Capacitance of a capacitor.
 - A dielectric material?
- b) i) Explain the effects of a dielectric on the capacitance of a capacitor
- Derive the expression for the effective for the capacitance of three capacitors in parallel.

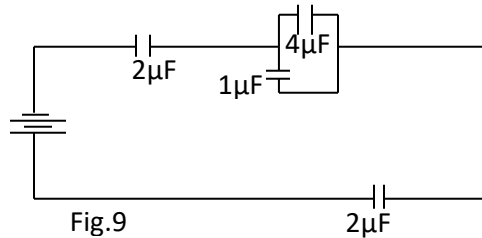

- c) Figure 9 shows network of capacitors connected to a d.c supply of 120V
- Calculate the
- Charge of $4\mu\text{F}$ capacitor
 - Energy stored in $1\mu\text{F}$ capacitor

Physics paper two 1998 Nov

- a) Describe and experiment to determine the focal length of a concave lens using a convex of known focal length

b) A convex lens and a concave lens of focal length 17.5 and 15.0cm respectively are mounted coaxially 7.5cm apart with the concave lens facing a distance object. Find

 - the final position of the image
 - The magnification of the image produced by the concave lens
- c) explain why a parabolic mirror is used in search lights instead of a concave mirror

d) Describe between the angle of a prism can be measured using a spectrometer

e) Differentiate between chromatic and spherical aberrations
- a) Define the terms refraction and refractive index

b) derive an expression for the apparent displacement of an object when viewed normally through a parallel sided glass block

c) i) A glass block of refractive index n_g is immersed in a liquid of refractive index n_l . A ray of light is partially reflected and refracted at the interface such that the angle

between the reflected ray and the refracted ray is 90° . Show that $n_g - n_l \tan \alpha$, where α is the angle of incidence from the liquid glass interface.

ii) When the procedure in (i) is repeated, with the liquid removed, an angle of incidence increases by 8° . Given that $n_l = 1.33$, find n_g and the angle of incidence at the liquid glass interface

d) A point source of the white light is placed at the bottom of a water tank in a dark room. The light from the source is observed obliquely at the water surface. Explain what is observed

3.

a) Use Huygens's principle to show the angle of incidence is equal to the angle of reflection for light falling on a plane reflecting surface

b) i) Draw a ray diagram showing the path of light rays through the experimental arrangement for the determination of the wavelength of light using a single slit and biprism.

ii. In a single slit and biprism experiment a prism of refracting angle 1.5° and refractive index 1.5 is used. The slit and the screen are 5cm and 1m respectively from the biprism. If light of waves 5.80×10^{-7} m is used. The slit and the screen are 5cm and 1m respectively from the biprism. If light of waves 5.80×10^{-7} m is used, find the width of the fringes

iii. State one advantage of the biprism method over Young's double method

c) Distinguish between continuous and line emission spectra

4. a) Explain the terms wave length and wave form as applied to wave motion

b) i) Define the term resonance

ii. Describe how you would determine the velocity of sound in air using a resonance tube

c) Explain with the aid of a suitable diagram the terms fundamental note and overtone as applied to a vibrating wire fixed at both ends

d) A stretched wire of length 0.75m radius 1.36mm and density 1380 kg m^{-3} clamped at both ends and plucked in the middle. The fundamental note produced by the wire has the same frequency as the first overtone in a pipe of length 0.15m closed at one end.

i) Sketch the standing wave pattern in the wire

ii) Calculate the tension in the wire

[The speed of sound along the stretched wire is $\sqrt{(T/\delta)}$] where T is the tension in the wire and δ the mass per unit length. Speed of sound in air = 330 m/s

SECTION B

5. a) A circular coil of N turns, each of radius R carries current I
- write an expression for magnetic flux at the center of coil
 - sketch the magnetic field pattern associated with the coil
 - Describe a simple experiment to verify the expression in (i) when N and R are constant.
- b) i) What is meant by magnetic moments of a current carrying coil?
 ii) A circular coil is 10 turns each of radius 10cm is suspended with its plane along a uniform magnetic field of flux density 0.1 T. find the initial torque on the coil when a current 1.0A is passed through it

c)

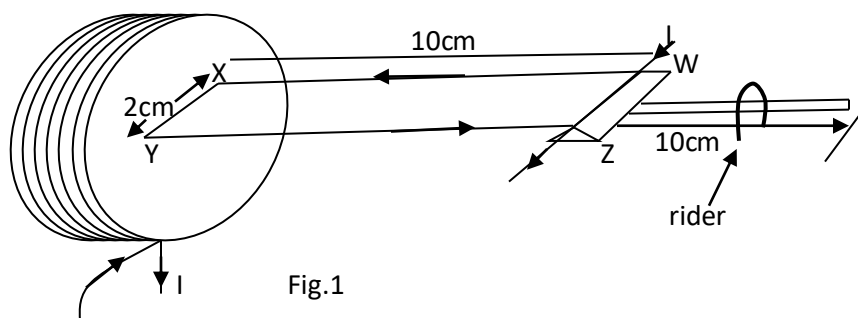

A rectangular loop of wire WXYZ is balanced horizontally so that the length XY is at the center of a circular coil of 500 turns of mean radius 10.0cm as shown in figure1. When a current I is passed through XY and the circular coil, a rider of mass 5.0×10^{-4} kg has to be placed at a distance of 9.0cm from WZ to restore balance. Find the value of the current I

6. a) i) Derive the relationship between peak value and root-mean square value of a sinusoidal current
- Calculate the root mean square value of an alternating current which dissipates energy in a heating coil immersed in a liquid in a calorimeter at two times the rate at which direct of 4A would if passed through the same coil under the same conditions.
- b) A source of sinusoidal voltage of amplitude $\frac{1}{0}$ and frequency f is connected across capacitor of capacitance C

- i) Without using any formula explain why a current apparently flows through the capacitor and is out of phase with the voltage.
- c) Draw a labeled diagram of a moving coil galvanometer and explain why it cannot be used to measure an alternating current

7. a) What is meant by

- i) mutual induction
- ii) Self induction?

b) Describe an experiment to demonstrate mutual induction .

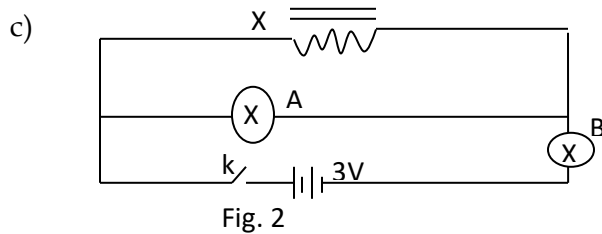

Bulbs A and B rates 3W, 6W are connected to an induction, X, of large inductance as shown in figure 2. Explain what is observed when

- i. switch K is first closed
- ii. switch K is first opened

d) i) Describe briefly the action of a transformer

ii) Describe briefly four causes of inefficiency in a transformer

e) A transformer is designed to work on 240V, 260V apply. It has 3000 turns in the primary and 200 turns in the secondary and its efficiency is 80%.

SECTION C

8. a)i) Draw the circuits diagram of the meter bridge and use it to derive the conditions for balance

ii) Explain why the meter bridge is insatiable for comparison of low resistance

iii) When resistor of resistance 4Ω and 8Ω are connected respectively in the left and right hand gaps of a meter bridge a distance point is obtained at a point a distance of 32.0cm from the left hand end of the bridge wire. On interchanging the resistors a balance point is obtained at appoint 68.0cm from the left hand

end. The resistance of the uniform wire of the meter bridge is 5Ω . Calculate the end errors.

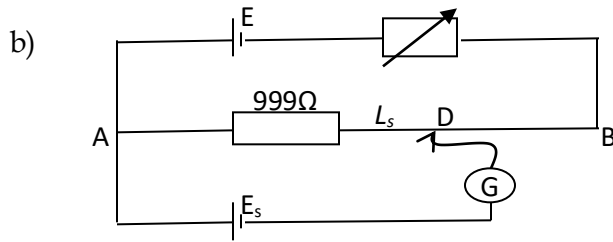

Fig. 3

In figure 3 above E is a driver cell of e.m.f 2V and AB is a uniform wire of resistance 10Ω and length 100.0cm. The galvanometer G show no deflection when $L_1 = 10.0\text{cm}$ find

- i. The current flowing in the driver circuit
- ii. The resistance of the rheostat
- iii. The e.m.f of a thermocouple which is balanced by a length of 60.0cm of the slide wire AB.

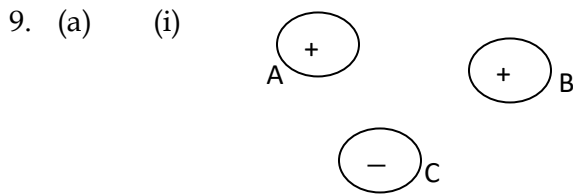

Fig. 4

In figure A, B and C are point charges of equal magnitudes

- i) sketch the field lines due to the charges and show the position of the neutral point
 - ii) Explain why a charged material attracts an uncharged conductor
- (b) i) With the aid of a labeled diagram describe how electric potential can be built using a Van der Graff generator.

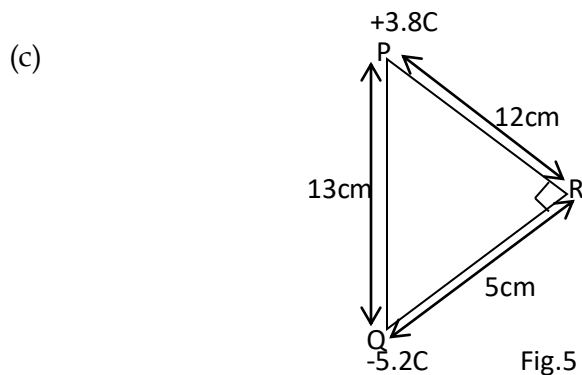

Fig.5 76

Two point charges of $+3.8\mu\text{C}$ are placed in air at points P and Q as shown in figure 5. Determine the electric field intensity at R

10. What is meant by capacitance of a capacitor?

b) Describe an experiment you would carry out verify that the capacitance of a parallel plate capacitor is promotional to ϵ is the permittivity of the medium between the plates

c) i) Derive an expression for the effective capacitance of three capacitors of capacitance C_1, C_2 and C_3 connected in parallel.

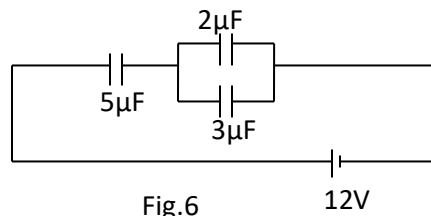

A battery of e.m.f 12v is connected across a system of capacitors as shown in figure 6.

Calculate the total energy stored in the capacitors.

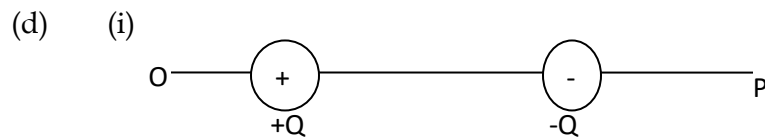

Figure 7 shows two Charges $+Q$ and $-Q$ placed along a line OP. sketch the variation of electric potential along OP.

(i) Explain with the aid of a diagram the term electrostatic shielding.

Physics paper two 1997

1. a) Describe giving the relevant equations, how the refractive index of a liquid can be determined using a concave radius of curvature

b) An object is placed 30cm from a converging lens of a focal length 10cm and an image formed on a screen. When a diverging lens is placed half way between the converging lens and the screen. The screen has to be moved 4.5sm father to obtain a clear image. Calculate the focal length of the diverging lens

c) Explain the apparent shape of the bottom of a pool of water to an observer at the bank of a pool.

- d) Figure 1 show a ray of light incident on a glass prism of refractive index 1.5.
Calculate the angle of emergence of the ray.

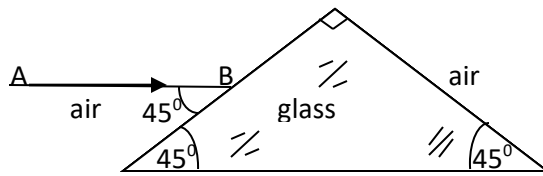

Fig.1

2. a) i) What is the curvature of a concave mirror?
ii) With reference to a convex lens explain what is meant by spherical aberration
b) A lens l a plane mirror, nt and a screen, s are arranged as shown in figure 2 so that a sharp image of luminous object o is formed on the screen s . when the plane mirror the lens has to be moved 5cm further away from the screen so as to obtain a sharp image on the screen.

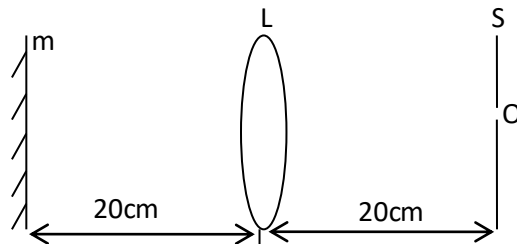

Fig.2

- i. Illustrate the two situations by sketch ray diagrams
ii. Calculate the focal length of the convex mirror.
- c) i. The deviation d by a prism of small angle, A , and refractive index n is $d = (n-1)A$.
Use this to show that the focal length of a thin converging lens of refractive index n is given by $\frac{1}{f} = (n-1)\left(\frac{1}{r_1} + \frac{1}{r_2}\right)$ where r_1 and r_2 are the radii of curvature of the lens surfaces.
ii. Calculate the focal length of a converging meniscus with radii 25cm and 20cm. and refractive index 1.5
3. a) What is meant by the terms path difference and interference?
b) i) Explain how interference fringes are formed in an air-wedge film between two glass slides when monochromatic light is used.
ii. Describe the appearance of the fringes when white light is used.
c) Two glass slides in contact at one end are separated by a metal foil 12.50cm from the line of contact to form an air-wedge. When the air-wedge is illuminated normally

be light of wavelength $5.4 \times 10^{-7} \text{ m}$ interference fringes of separation 1.5mm are found in reflection. Find the thickness of the metal foil.

- d) i) Describe the one method of producing plane polarized light
 ii) Name two uses of polarized plane light.
4. a) State Huygens's principle
 b) Use Huygens's principle to derive the relation between critical angle and refractive indices two media in contact.
 c) Explain the function of beats and derive the expression for the beat frequency
 d) The equation: $y = a \cos (\omega t - kx)$
 i) Speed of the wave
 ii) Direction in which the wave is travelling.
 iii) resultant wave when the wave is superposed with a wave represented by

$$y = a \cos (\omega t - kx)$$

 e) State any two characteristics of the wave in d) iii) above
 f) Air vibrates in the fundamental mode in a pipe of uniform cross sectional area open at both ends.
 g) State the conditions of pressure at the ends of the pipe and sketch a diagram to show the first overtone in the pipe

SECTION B

5. a) State Lenz's law of electromagnetic induction
 ii) Describe an experiment to verify Lenz's law
 b) In the circuit in figure 3. A and B are identical bulbs.

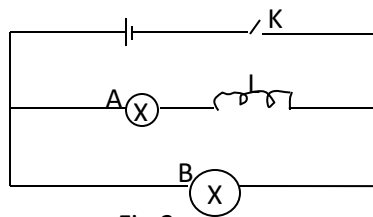
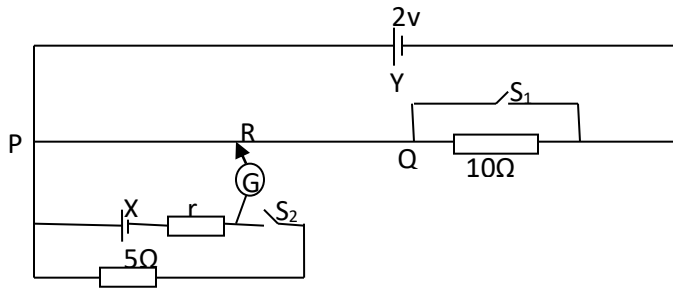

Fig.3

- i. Sketch using the same axes, the time variation of the current through each bulb when switch k is closed
 ii. Explain the features of the curves in i)
 iii. Explain what would be observed, on closing the switch, if the coil L was iron-cored and the battery was replaced with an alternating current source.

- d) Describe briefly one application of self induction
- e) Draw a labeled diagram of an induction coil and explain how it operates
6. a) i) Briefly describe how a slide wire potentiometer works
- ii) explain one advantage of using a potentiometer over a moving coil voltmeter
- b) With the aid of circuit diagram describe how an ammeter is calibrated
- c) The figure below shows a cell Y of negligible internal resistance with e.m.f 2v PQ is a uniform slide wire of length 1.00m and resistance 50Ω.



- With both switches s_1 and s_2 open the balance length PR is 0.90m. When s_2 is closed and s_1 left open, the balance length changes to 0.75m?
- e.m.f of cell X
 - internal resistance r of X
 - balance length when both s_1 and s_2 are closed
7. a) With the aid of a labeled diagram describe how a simple d.c motor works
- b) i) What is meant by back e.m.f in a motor?
- ii) Explain the importance of back e.m.f in the operation of a motor
- c) i) Show that back e.m.f in the coil of a motor rotating at ω radians per second in a radial magnetic field, of flux density B is $E = \omega NAB$ where N is the number of turns and A the area of the coil.
- ii) The coil of a d.c motor is mounted in a radial magnetic field of flux density 1T. The coil has 20 turns each of area 40cm² and total resistance 2Ω. Calculate the maximum angular velocity the motor attains when working on 240V and drawing a current of 1A.
- d) i) Find the force per meter between two long parallel wires 5cm apart and carrying currents of 2A and 4A in opposite direction in a vacuum.

SECTION C

8. a) i) What is meant by e.m.f of a cell?
 ii) Describe, with the aid of a circuit diagram how the e.m.f of a cell can be determined using a potentiometer
 b) Explain why two cells connected in series deliver more current than when in parallel.

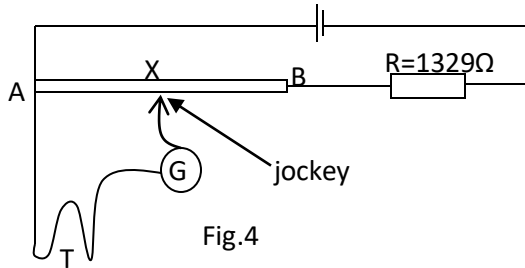

The e.m.f of a thermocouple is determined using the circuit shown in figure 4. The resistance of the wire AB is 4.0Ω

- i. Explain why resistor R is connected in the circuit
 - ii. The galvanometer G, deflected to the left when the jockey was tapped near A to the right when tapped near B and shown no deflection when tapped at X. Explain.
 - iii. If the galvanometer G has a resistance of 98Ω and the resistance of the thermal couple is negligible, find the current that flows through G when the balance point is mid-way between A and B.
 - iv. State the assumptions made in b(iii).
9. (a) (i) Define electric field intensity.
 (ii) Describe how a conducting body may be positively charged but remains at zero potential.
 (iii) Explain how the presence of a neutral conductor near a charge conducting sphere may reduce the potential of the sphere.
- (b) Figure 5 shows charges $Q_1, Q_2, Q_3,$ and $Q_4,$ of $-1C, +2C, -3C$ and $+4C$ arranged in a straight line in a vacuum.

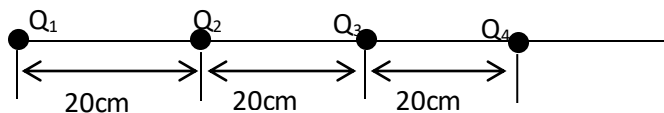

Fig.5

- i) Calculate the potential energy of Q_2 .
- ii) What is the significance of the sign of the potential energy in (i) above?
- iii) Explain how a body may acquire charge by rubbing.
- (c) **What is** meant by corona is charge?
10. (a) What is a dielectric constant?
- (b) (i) Explain the effect of a dielectric placed between the plates of a charged conductor.
- (ii) Give two other uses of dielectrics in capacitors.
- (c) Explain what would happen if a conductor instead of a dielectric was placed between the plates of a capacitor.
- (d) A $2\mu\text{F}$ capacitor that can just withstand a p.d of 5000V uses a dielectric. With a dielectric constant 6 which breaks down if the electric field strength in it exceeds $4 \times 10^7 \text{ m}^{-1}$.
- Find the
- (i) Thickness of the dielectric
- (ii) Effective area of each plate
- (iii) Energy stored per unit volume of the dielectric

[The capacitance, $= \frac{\epsilon}{4\pi k}$: where

Physics paper two 1996

1. a) State the laws of refraction
- ii) What is meant by critical angle?
- b) Monochromatic light is incident at an angle of 38° on a glass prism of refractive index 1.50. The emergent light grazes the surface of the prism as shown:

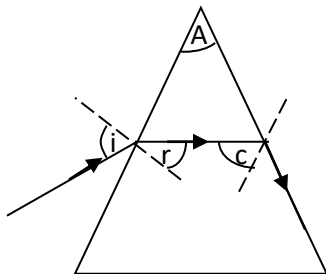

- i. Calculate the angle of refraction, r

- ii. Find the critical angle, c , for the glass-air interface
 - iii. Find the refractive angle, A , of the prism.
- c) i) For a ray of light passing through a prism, what is the condition for minimum deviation to occur?
- ii) Find the critical angle, c , for the glass -air interface
 - iii) Find the refractive angle, A , of the prism.
- d) i) For a ray of light passing through a prism, what is the condition for minimum deviation to occur?
- ii. Describe how you would measure the minimum deviation, D , of a ray of light passing through a glass prism
 - iii. If the angle of minimum deviation in c) ii) above is 41° for a glass prism of refractive angle 60° . Find the refractive index of glass.
2. a) i) What is meant by principle axis and principal focus as applied to a converging lens.
- ii. Describe how the focal length of a converging lens can be obtained using a plane mirror and the non-parallax method.
- b) A converging lens of focal length 20cm is placed coaxially with diverging lens of focal length of 6cm
- i. If the lenses are 12cm apart, determine the position of the image of a distant object placed on the same side as the converging lens.
 - ii. What is the nature of the image formed in b) i) above?
- c) i) Trace the path of three rays from a distant object through an astronomical telescope in normal adjustment
- ii) An astronomical telescope consist of two thin converging lenses of focal length 100cm and 10cm respectively. If the final image of a distant object is virtual and is 20cm from the eye-piece find the separation of the lenses.
 - iii) State any two advantages of a refracting telescope over a reflecting one
3. a) Distinguish between transverse and longitudinal waves
- b) The displacement y given of a wave travelling in the x - direction at time t is

$$y = a \sin 2\pi \left(\frac{t}{0.1} - \frac{x}{2.0} \right) \text{ meters}$$

Find i) the velocity of the wave

- ii) The period of the wave
 - c) i) what is meant by the Doppler Effect?
 - iii) A police car sounds siren of 1000 Hz as it approaches a stationary observer
 - iv) What is the apparent frequency of the siren as heard by the observer if the speed of sound in air is 340ms^{-1} ?
Give one application of the Doppler Effect (i)
 - d) I) Describe the motion of air in a tube closed at one end and vibrating in its fundamental mode
 - ii) A cylindrical pipe of length 29cm is closed at one end. The air in the pipe resonates with a tuning fork of frequency 860Hz sounded near the open end of the tube. Determine the mode of vibration and find the end correction.
4. a) What is meant by the terms
- i. constructive interference and
 - ii. Destructive interference as applied to two sources of light.
- b) In Young's double slit experiment state what happens to the fringes.
- i. When the source is moved near the slits?
 - ii. When separation of the slits is changed?
- c) In Young's experiment, an interference pattern in which the tenth bright fringe was 3.4cm from the center of the pattern was obtained. The distance between the slits and the screen was 2.0m while the screen separation was 0.3mm. find the wavelength of the light source
- d) i) What is polarized light?
- ii) Explain the polarization of light by reflection at a glass surface and by scattering
 - iii) The polarizing angle for light in air incident on a glass plate is 57.5° . What is the refractive index of the glass?
5. a) i) Define the unit magnetic flux density.
- ii) Give the expression for the force experienced by an electron moving at an average velocity v_1 in a wire placed at right angle to a magnetic field of intensity
- b) i) With the aid of a labeled diagram describe the mode of operation of a moving coil galvanometer

ii. A rectangular coil of 100 turns is suspended in a uniform magnetic field of flux density 0.027 with coil is the coil parallel to the field. The coil is 3cm high and 2cm wide. If the current of 50μF through the coil occurs a deflection 30cm suspension

c)i) Define the ampere

ii) Explain how the definition in c(i) above is used in the measurement of current

iii) Two parallel wires carrying current of 5A and 3A respectively are 10cm apart. If the wire carrying current of 5A is 50cm long. Find the force exerted on it

6. a) State the laws of electromagnetic induction

b) A coil of 100 turns and area $2 \times 10^{-2} m^2$ lies in a magnetic field of flux density $3 \times 10^{-3} T$ and rotates uniformly at 100 revolutions per second about an axis perpendicular to the magnetic field as shown.

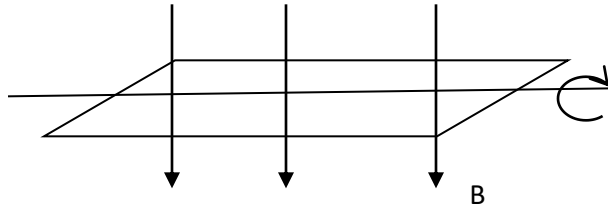

Calculate

i. the emf induced when the plane of the coil makes 60° with B

ii. the amplitude of the induced emf

c) i) What is meant by the back emf in a motor?

ii) State the major difference between a d.c motor and a d.c dynamo

iii) What are eddy current? give one examples where eddy current are useful and one example where they are a nuisance

d) A dc motor has an armature resistance of 1Ω and is connected to a 240-v supply. The armature current taken by the motor is 10A calculate

i. The back emf in the armature

ii. The mechanical power developed by the motor

iii. The efficiency of the motor.

7. a) i) What is meant by the root-mean square value of an alternating current?

- ii) Describe, with the aid of a labeled diagram, the structure and mode of operation of repulsion type moving iron motor.
- b) A sinusoidal alternating voltage $v = v \sin \omega t$. Is connected across a pure capacitance c . Derive an expression for the capacitive reactance of the capacitor
- c) A transformer connected to an ac supply of peak voltage 240V is to supply a peak of 9V to a min lighting system of resistance 50

Calculate

- i. The ratio of the primary to the secondary turns
- ii. The rms current supplied by the secondary
- iii. The average power delivered to the lighting system
- d) i) Explain why the voltage of the electric generated at Owen Falls Dam has to be stepped up to about 132 kV for transmission places in the Western Region, and then stepped down for general use.
- ii) Give any two power losses in a transformer state how they are minimized.

SECTION C

8. a) i) State Ohm's law

b) A 12-v battery is connected across a potential divider of resistance 600Ω as shown. If a load of 100Ω is connected across the terminals A and C where the slider is half-way up the divider, find

- i. the p.d across the load
- ii. The p.d across A and C when the load is removed.

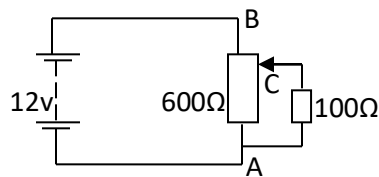

- c) i) Describe how a potentiometer is used to determine the emf of a cell
- ii) in the determination in c) i) above, why is the resistance not important?
- iii) How the procedure in c) i) above would modify to measure the internal resistance to the cell?
- d) A battery of emf 12v and internal resistance 0.5Ω is connected across a 6Ω load.
 - i. The rate of energy conversion in the battery
 - ii. The rate of dissipation of electrical energy in the resistor.

- iii. Comment on the difference in (i) and (ii)
 - iv. Sketch a graph showing the variation of power out. It with the load.
9. a) i) What is meant by dielectric constant?
- ii) A parallel plate capacitor was charged to 100v and then isolated. When a sheet of dielectric was inserted between its plates, the p.d decreased to 30V. Calculate the dielectric constant of the dielectric.
- b) A $60\mu\text{F}$ capacitor is charged from a 100V supply. It is then connected across the terminals of $15\mu\text{F}$ uncharged capacitor. Calculate
- i) The final p.d combination
 - ii) The difference in the initial and final energies stored in the capacitors and comment on the difference.

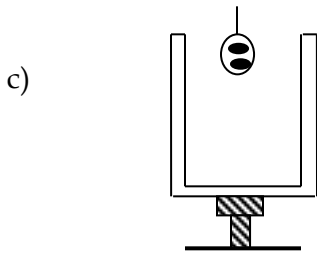

A charged conducting ball is suspended by an insulating thread and is gently lowered in a conducting container placed on an insulating stand.

Explain the distribution of charge on the conductor when

- i. The ball is well inside the container still suspended
 - ii. The ball touches the inner surface of the container
- d) i) Explain how lightning can cause damage to building
- ii) Explain the action of a lightning conductor

10. a) Define temperature coefficient of resistance

b) The table shows the resistance of wire different temperature

| | | | | | |
|----------------------------|-----|-----|-----|-----|-----|
| Temp($^{\circ}\text{C}$) | 30 | 50 | 70 | 90 | 110 |
| Resistance (Ω) | 103 | 107 | 111 | 115 | 119 |

Plot a graph of resistance against temperature to find

- i. the resistance of the wire at $^{\circ}\text{C}$
 - ii. the temperature coefficient of the wire
- c) i) Derive the condition for balance when using meter-bridge of measure taken to achieve an accurate measurement.

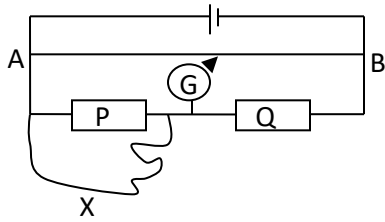

In the diagram, the resistors P and Q are 5Ω and 2Ω respectively. A wire X of length 60cm and diameter 0.02mm is connected across P so that the balance point is 66.7cm from A. Calculate the resistivity of the wire.

Physics paper two 1995

SECTION A

1. a) State the refraction of light
- b) Show that when a ray of light through different media separated by plane boundaries

$$\mu \sin i = \text{constant}$$

Where μ is the absolute refractive index of a medium and i is the angle made by the ray with the normal in the medium.

- c) Describe how you would determine the refractive index of a liquid using an air-cell
 - d) A ray of light is incident on a prism of refractive index 1.3 and refracting angle 72° the ray emerges from the prism at an angle of 43°
 - i. The angle of incidence
 - ii. The deviation of the ray
 - e) Describe briefly two uses of glass prism
2. a) What is meant by the term radii of curvature as applied to a converging lens?
 - b) i) Show that the focal length f of a converging lens is given by:

$$\frac{1}{f} = (\mu - 1) \left[\frac{1}{r_1} + \frac{1}{r_2} \right]$$

Where μ the refractive index of the material of the lens is r_1 and r_2 are the radii of curvature of the surface of the lens.

- ii. A biconvex lens of radius of curvature 24cm is placed on a liquid film on a plane mirror. A pin clamped horizontally above the lens coincides with its image at a distance of
 - c) Describe, with the aid of a labeled diagram, the functions of the essential parts of a photographic camera
 - d) A projector is required to project slides which are 50cm across onto a screen which is 5.0m square.
3. a) What is sound?
- ii. In what ways do musical sounds differ from one another?
- b) With the aid of a labeled diagram, describe an experiment to demonstrate interference of sound waves. Give the relevant theory
- c) A glass, open at the top, is held vertically and filled with water. A tuning fork vibrating at 264Hz is held above and water is allowed to flow out slowly. The first resonance occurs when the level is 96.3cm from the top.
- i) The speed of sound in the air column
 - ii) the end correction
- d) Why is sound propagation in air considered to be an adiabatic process?
4. a) Discuss briefly nature of light
- b) Distinguish between polarized light can be produced by
 - c) Discuss between unpolarized and polarized by
 - i. reflection
 - ii. selective absorption

Indicate the procedure you would use to detect the polarized light
 - d) Explain why the sky appears blue on a clear day
 - e) i) Explain, with the aid of the diagram, the formation of a spectrum transmission grating.
 - ii) State the advantages of the transmission grating glass prism in determining the wavelength of a source.
 - f) State one application of polarization
5. a) Explain the difference between magnetic flux and magnetic flux density
- b) i) Two long conductors carrying a current are placed parallel to each other in a vacuum at a distance d meter apart.

Derive an expression for the force per unit length acting on each wire when a current i_1 amperes flow through one i_2 ampere flows through the other.

- ii. How does the expression in i) lead to definition of the ampere?
- c) i) A small rectangular coil of N turns with a cross sectional area A is suspended so that it can rotate about a vertical axis through the center of its shorter sides.
ii) Explain the additional required if the arrangement described in i) is to be used to measure current
What modifications are necessary to achieve a linear scale?
- d) A coil of cross sectional area $1.6 \times 10^{-3} m^2$ is to be used to produce a uniform magnetic flux density of $1.5 \times 10^{-3} T$
 - i. Where will the magnetic field be uniform?
 - ii. Calculate the total flux through the coil
6. a) i) With the aid of a diagram, describe an experiment to determine how the e.m.f induced in a metal rod moving in a magnetic field depends on the rate of change of magnetic flux.
ii. Explain how Lenz's law is an example of energy conservation
b) i) Give an expression for the magnetic flux density at the center of a long solenoid of n turns per meter and carrying a current I
ii. A circular aluminum disc, of radius 30cm, is mounted inside a solenoid of 2×10^3 turns per meter carrying a current of 20.0A such that its axis coincides with that of the solenoid. If the disc is rotated its axis at 40 revolutions per minute, what will be the e.m.f induced?
- c) i) What is meant by the term magnetic field?
ii) An iron-cored coil of many turns is connected in series with an ammeter, an accumulator and a switch. The switch is closed and the movement of the pointer of the ammeter observed. The coil is replaced by a resistor of the same resistance as the coil and the movement observed again when the switch is closed.
Explain the movement of the pointer in each case
7. a) What is meant by the term magnetic field?
b) i) Write the expression for the magnetic flux density at the center of a circular coil of N turns of radius R and carrying a current I

- ii) A copper wire of length 7.85m is wound into a circular coil of radius 5cm. a current of 2A is passed through the coil

Calculate the magnetic flux density at the center of the coil.

- c) Describe how you would detect the magnetic field at a point close to a long straight wire carrying an alternating current.
- d) Describe with the aid of a labeled diagram, the structure and function moving iron ammeter.
- e) An alternating current I_i is given a coil of inductance L as shown in figure 1.

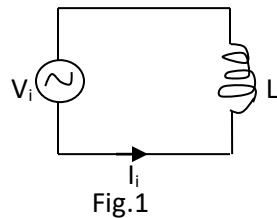

The instruction values of $I_t = I_m \sin 2\pi f t$ where I_m is amplitude and f is the frequency

- Derive an expression for the voltage v_1 across the coil
- Show on the same sketch graph how v_1 and I_1 vary with time t

SECTION C

8. a)i) State Coulomb's law of electric potential energy of two point charge Q_1 and Q_2 a distance apart

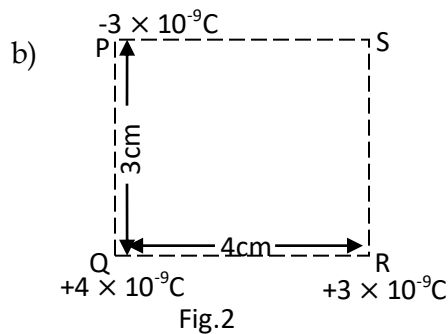

Three charge of $3 \times 10^{-9} \text{C} = 4 \times 10^{-4} \text{C}$ and $+3 \times 10^{-9} \text{C}$ are placed in a vacuum at the vertical P, Q and R respectively of a respectively of a rectangular PQRS of side 3cm is 4cm as shown in figure at S.

- What is on equipotential surface?
- State the characteristics of an equipotential surface

- d) Describe an experiment to show that a charge outside a hollow conductors.
9. a) A conducting sphere of radius 9.0cm is maintained at an electric potential of 10kV.
 b) Sketch a graph of:
 i) Electric potential
 ii. electric field internally.
 Against distance for a charge parallel plate capacitor whose separation of plate is fixed.
- c) Use a simple atomic model to explain the effect of inserting an insulating material between the plate of the capacitors in b)
- d) i) Describe the energy changes which occur when a capacitor is being charged from a battery
 ii. Sketch a graph of current against time during the charging of a capacitor Explain how you would use the graph on the plate of the capacitor.

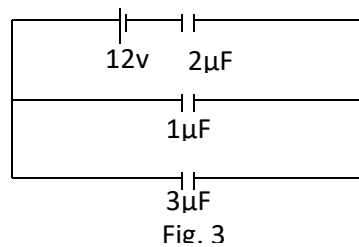

Fig. 3

Find the energy stored in the capacitor 3μF shown in figure 3 when the capacitor is fully charged.

10. a) Define electrical resistivity
 b) i) Draw a circuit diagram of a meter-bridge
 ii) Describe how the meter bridge may be used to measure the electrical resistivity of a material in the form of wire.
 iii. A resistance coil is connected across the left gap of a meter bridge. When a 5.0Ω standard resistor is connected across the right hand gap of the meter bridge and the coil is immersed in an ice-water mixture, the balance point is at a point 45.0cm from the left hand end of the bridge
 When the coil is immersed in a steam bath at 100°C, the balance point shifts to a point 52.8cm from the left hand of the bridge. Find the temperature coefficient of the material of the coil.

- c) In the circuit shown in figure 4. AB is a uniform wire of length 1m and resistance 4.0Ω . C_1 is an accumulator of e.m.f 2V and negligible internal resistance. C_2 is a cell of e.m.f 1.5V.

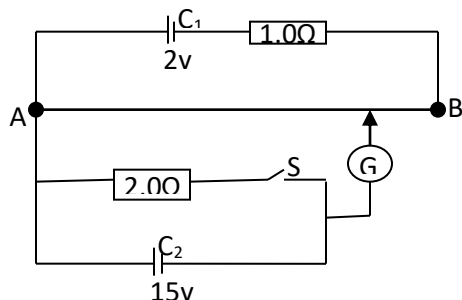

Figure 4

- i. Find the balance length AD when the switch is open
- ii. If the balance length is 75.0cm when the switch is closed. Find the internal resistance of C_2

Physics paper two 1994

1. a) Describe how you would measure the refractive index of glass a spectrometer.

b)

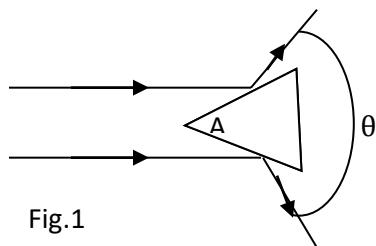

Fig.1

A parallel beam of light is incident onto a prism of a refracting angle A as shown in figure 1.

Show that $\theta = 2A$

- c) A glass prism of refractive index 1.5 and refracting angle 60° is completely immersed in a liquid of refractive index 1.3.

If a ray of light passes symmetrically through the prism, calculate

- i. the angle of incidence
 - ii. the angle of deviation
- d) A liquid is placed in a concave mirror to a depth of 2cm. an object held above the liquid coincides with its own image when it is 45.5cm from the pole of the mirror.

- e) Explain why a parabolic mirror is used in search lights instead of a concave mirror
2. a) What is meant by the terms principal focus and focal length of a converging lens
- b) Name one defect of images formed by a lens and explain how the defect is minimized in practice.
- c) The magnification of an object in a thin converging lens is m . when the lens is moved a distance d towards the object, the magnification becomes m' show that the focal length f of the lens is given by

$$f = \frac{dmm'}{m' - m}$$

- d) a converging lens L_1 of focal length 10cm is placed at a distance y in front of a diverging lens L_3 of focal length 20cm. an illuminated object is placed at a distance of 20cm in front of L_1 and the final image by L_2 forms at the principal focus of L_2
- Calculate
- the distance y
 - the final magnification
- e) explain
- Why an object far away from the eye appears to be smaller than when it is near
 - How loss of light by refraction of refractive surface can be minimized
3. a) Define the terms *frequency* and *amplitude*
- b) Give two examples of wave form motion
- c) A wave of amplitude 0.2m wavelength 2.0m and frequency 50Hz propagates in the positive x-direction
- If the initial displacement is zero at point $x=0$
- write the expression for the displacement of the wave at any time t
 - Find the speed of the wave.
- d) Two waves of frequencies 256Hz respectively travel with a speed of 340ms^{-1} through a medium
- e) Explain how energy is transmitted in a progressive wave in a gas.
- f) Design an experiment to demonstrate that a metal wire under tension can vibrate with more than one frequency.
4. a) State the conditions for observing an interference pattern and explain why these conditions are necessary
- b) What is meant by diffraction?

- c) i) Account for the intensity distribution which occurs when a parallel beam of light passes through a narrow slit
 ii. What happens to the intensity distribution when the slit is enlarged?
- d) Describe the principle involved in the formation of interference fringes in a double slit arrangement

SECTION B

5. a) Write the expression for the magnetic flux density at
- i. A perpendicular distance R from a long straight wire carrying a current I in a vacuum.
 - ii. The center a circular coil, of N turns of radius R and carrying a current I
 - iii. The center of an air-cored solenoid of n turns per meter each carrying a current I
- b) Sketch the pattern of the earth's magnetic field
- c) Explain the term magnetic meridian, angle dip and declination
- d) A circular coil of 5 turns of mean diameter 10cm is mounted with its plane vertical and along the magnetic meridian. A small compass needle is mounted on a vertical axis at the center of the coil.

When a current of 0.50A is placed through the coil, the compass needle deflects through 61° . When the current in the coil is reversed, the compass needle deflects through 59°

Calculate the horizontal component of the earth's magnetic field intensity

- e) i) What is meant by magnetic flux?
 ii) A current 1.0A flows in a long solenoid of 1000 turns per meter. If the solenoid has mean diameter of 8.0cm. Find the magnetic flux linkage with one meter-length of the solenoid.
6. a) State the laws of electromagnetic induction
 b) A circular coil of many turns is fixed with its horizontal as shown in figure 2.

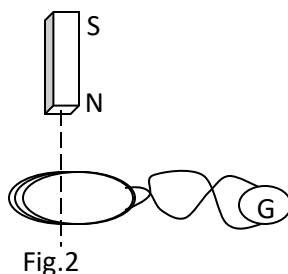

The ends of the coil are connected to a center zero galvanometer G . a magnet is released from rest so that it falls vertically through the coil
Sketch a graph of deflection of the galvanometer against time of fall of the magnet and explain the main characteristics of the graph.

- c) Distinguish between self induction and mutual induction
- d) State three factors which limit the efficiency of a transformer and indicate how they are minimized in practice.
- e) An a.c transformer operates on 240 mains. It has 1200 turns in the primary and gives a voltage of 18V across the secondary.
 - i. Find the number of turns in the secondary
 - ii. If the efficiency of the transformer is 90%. Calculate the current in the primary coil when a resistor of 50Ω is connected across the secondary.

7. a)i) What is meant by back e.m.f in a d.c motor?

ii. Show how the back e.m.f in a motor is related to the efficiency of the motor.

b) With the aid of labeled diagram, explain how a hot wire ammeter works

c) i) Define root mean square value of an alternating current.

ii. A current $I=8.0 \sin 100\pi t$ amperes is maintained in a heating coil immersed in 20kg of water. The resistance in a coil is 5Ω . Find the temperature rise obtained in 5 minutes

State the assumptions made.

d) A capacitor capacitance C and infinite resistance across source of alternating voltage and variable frequency f .

i. Find an expression for the reactance of the circuit and sketch its frequency dependence

ii. Using the same axes, show how the applied voltage and current in circuit vary with time.

Comment on the time variation.

SECTION C

8. a) What is meant by internal resistance of a battery?

b) In the circuit figure 3, the voltmeter V has a resistance of 400Ω .

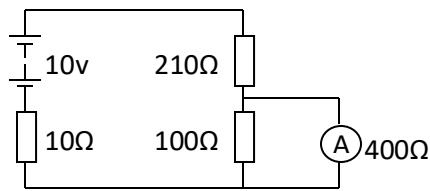

Figure 3

- i. Find the reading of the voltmeter
 - ii. Calculate the power dissipated in the 100Ω resistor
 - iii. What voltage would be obtained if the voltmeter was replaced by a cathode ray oscilloscope?
 - iv. Explain the difference between the voltages obtained in i) and iii) above
- c) Explain why in a dynamo, the load resistance is usually bigger than the armature resistance
- d) Define potential difference and Coulomb
- e) A particle charge $+4 \times 10^{-9}$ is situated between two parallel plates across which a d.c potential difference applied. When the particle is moved 6.0cm against the electric field $8 \times 10^{-5}J$ of energy is used and the kinetic energy of the particle changes by $6.5 \times 10^{-5}J$.

Calculate

- i. The work done by the electric field
 - ii. The magnitude of the electric field
9. a) With the aid of a labeled diagram, describe how a Wheatstone bridge can be used to determine the value of a resistance of a proximately 5Ω . Include the relevant theory in your description.
- b) State two factors on which the accuracy of the measurement obtained from a Wheatstone bridge depends
- c) In the circuit shown in figure 4 S is a standard cell of e.m.f 1.2V

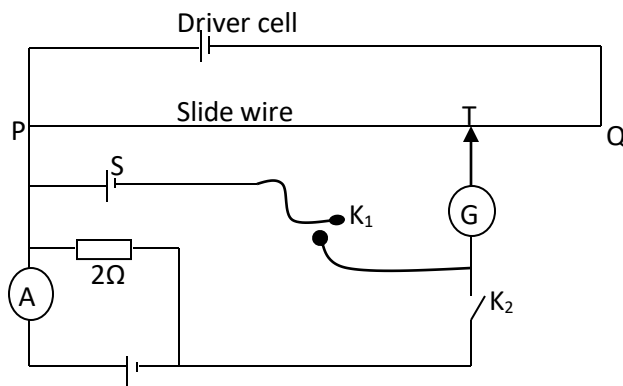

Fig. 6

With switch K_1 closed and switch K_2 open, the balance length PT is 30.2cm when K_1 is open and K_2 is closed, the balance length becomes 26.8cm and the ammeter A reads 0.4A

Calculate the percentage error in the ammeter reading.

- d) A wire diameter d , length l and resistivity ρ forms a circular loop. A current enter and leaves at points P and Q respectively as shown in figure 5.

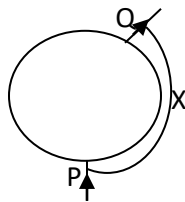
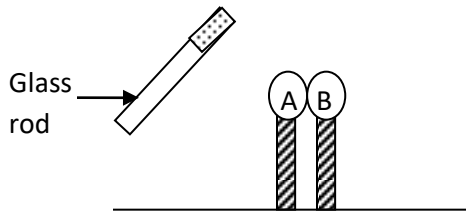

Fig. 5

Show that the resistance R , of the wire is given by the expression:

$$R = \frac{4\rho x(l-x)}{d^2l}$$

10. a) Explain how an object gets charged by rubbing.
 b) Two metal spheres A and B are supported on insulating stands and placed in contact as shown in figure 6.



A glass rod, charged positively, is held close to sphere A. The sphere is then separated while the glass rod is place.

- i. State the charge acquire by each of the sphere
 - ii. Sketch the electric field pattern the sphere
 - iii. Explain how the p.d between the spheres changes as the spheres are moved further apart.
- c) Describe, with the aid of a labeled diagram, the application of corona discharge in a van der Graff generator.

- d) Find the resultant electric field intensity at point, due to charges shown in figure 7.

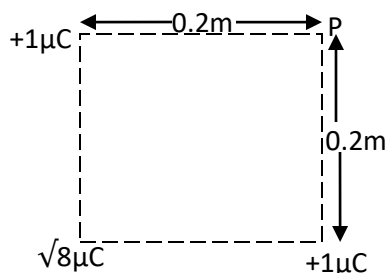

Fig.3

Physics paper two 1993

SECTION A

1.
 - a) Define angular magnification of an optical instrument
 - b) Describe, with aid of a ray diagram, the operation of a telescope up to a converging and a diverging lens when used in normal adjustment. State one limitation of this type of telescope.
 - c) A telescope consists of a converging and a diverging lens of focal length 1.5m and 0.3m respectively. When it is used to read a scale 15.0cm from the objective. The final image is formed 0.6m from the eyepiece. Find the separation of the lenses.
 - d) Draw a ray diagram to show the action of a projector.
 - e) A point source of white light is placed at the bottom of a water tank in a dark room. The light from the source is observed obliquely at the water surface
2.
 - a) Differentiate between each of the following pairs
 - i. regular reflection and diffuse reflection
 - ii. line emission spectra and continuous emission spectra
 - b) Explain the term *focal point* as applied to a lens
 - c) A converging beam of light in the shape of a cone with a vertex angle of 40° falls on a circular diaphragm of diameter 20cm. when a converging lens is fixed in the diaphragm; the new vertex angle is 73° calculate
 - i. the focal length of the lens
 - ii. The displacement of the vertex of the cone
3.
 - a) i) What is meant by radius of *curvature of a curvature mirror*?
 - ii) Show that the radius of curvature r of a concave mirror is given by the expression: $r = 2f$ where f is the focal length of the mirror.

- b) Describe how the refractive index of a liquid be determined using a concave mirror.
- c) A ray monochromatic light enters one face of 60° glass prism and is totally internally reflected at the face
- Draw a diagram to show the path of light through the prism
 - Calculate the angle of incidence at the first face if the refractive index of glass is 1.53 and the angle of incidence at the second face is 42°
- d) Explain how images are formed

SECTION B

4. a) State Ohm's law.
- b) State the current voltage characteristics for very small voltage ranges of
- a piece of metallic wire
- Two electrodes immersed in an electrolyte
- c) Give two devices to which Ohm's law does not apply and sketch their current voltage characteristics
- d) Draw a circuit diagram to show how the value of a high resistance can be determined using a low resistance ammeter and high resistance voltmeter
Justify your connection of the ammeter and voltmeter.

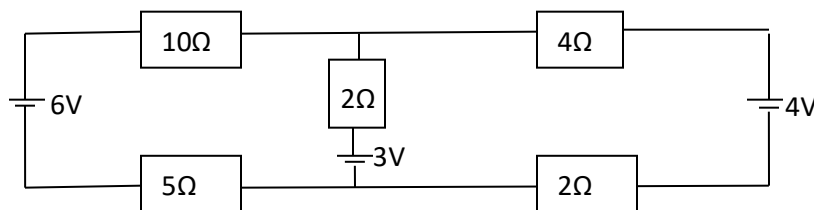

Fig.1

In the circuit diagram in figure 1

- Find the values of the current through the 10Ω , 3Ω , and 4Ω resistors
 - Calculate the power dissipated in the 5Ω resistor.
5. a) Outline the principles of operation of a slide potentiometer
- b) With the aid of a circuit diagram, describe how to calibrate an ammeter

d)

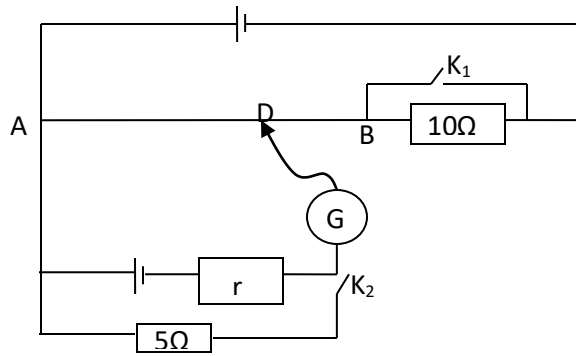

Fig.2

In the figure 2 a cell X, of negligible internal resistance, has e.m.f of 2V, AB is a uniform slide wire of length 100cm and resistance 50Ω. With both switches K_1 and K_2 open, the distance length AD is 90cm. when K_2 is closed and K_1 is left open, the balance length changes to 75cm. calculate

- i. the e.m.f of cell Y
- ii. the balance length when both K_1 and K_2 are closed

d) explain one advantage of a potentiometer over a moving coil voltmeter

6. a) State the laws of electromagnetic induction

b) i) Explain how eddy currents are produced

ii) Explain briefly two applications of eddy current

iii) Two parallel wires each of length 75cm are placed 10cm apart. When the same current is passed through the wires. A force of 5.0×10^{-5} N develops between the wires. Find the magnitude of the current.

c) With the aid of a diagram describe how the magnetic flux density B. between the poles of a strong magnet may be measure

7. a) Sketch field lines between two large parallel metal plates across which a p.d is applied.

b) Describe how you would investigate the factors which affect the capacitance of a parallel plate capacitor. Use sketch diagrams to illustrate your answer.

c) Explain how lightning can cause severe damage to building. Name one device that can be used to prevent such damage and explain how its operates

d) Show that the effective capacitance, C, of two capacitors of capacitance C_1 and C_2 connected in series is given by

$$C = \left[\frac{C_1 C_2}{C_1 + C_2} \right]$$

e) A $20 \mu\text{F}$ capacitor is charged to 40V and then connected across an uncharged $60\mu\text{F}$ capacitor. Calculate the potential difference across $60\mu\text{F}$ capacitor.

f)

SECTION C

8. a) Describe, with the aid of a labeled diagram, the determination of the velocity of light by Fizeaus rotating wheel method.
- b) Using Huygens's principle of wave propagation. Derive an experiment for the refractive index of a material in terms of the velocity of light
- c) A soap film formed on a vertical wire frame is viewed in white light. Explain what is observed as the soap film gradually drains.
- d) Light from a point source is reflected from a rotating six sided prism to a stationary mirror from which it is reflected back the prism along the same path. If the speed of rotation of the prism is 1000 revolutions per second and the image of the object is seen in the same position. Calculate the distance between the mirror and the prism
9. a) Explain what is meant by the term
- i. Bohr atom
 - ii. Binding energy
- b) State Rutherford's model of the atom and discuss the experimental evidence that supports it.
- c) i) Sketch a graph showing the variation of binding energy per nucleon with mass number
- ii) Use the graph in i) to explain how energy is released during fission and fusion
- d) During the fission of uranium. 235.200 Me V of energy is released. calculate the energy in joules released when 1.5kg of uranium takes part in a bomb explosion
10. a) Define *isotope*, *mass number*, *radioactivity*, and *activity of a radioactive material*.
- b) Outline the principle of detecting alpha and beta particles
- c) A steel piston ring contains 15g of radioactive iron. ^{59}Fe , of activity of 3.7×10^5 disintegrations per second. after 100 days of continuous use, the crank-case

oil was found to have a total activity of 1.23×10^3 disintegrations per second.

Find

- i. the half life of
- ii. The average mass of iron worn off the ring per day assuming that all the metal removed accumulates in the coil.

(Activity A and λN and $\lambda = \frac{0.693}{T_{v_2}}$)

- d) explain the application of carbon 1-4 in carbon dating
- e) state two precautions that should be taken by personnel working in a radioactive laboratory

END