

S6 BIOLOGY NOTES

NUTRITION IN PLANTS AND ANIMALS

Nutrition is the process by which organisms obtain energy to maintain life functions, and matter to create and maintain structure. Both energy and matter are obtained from nutrients.

Modes of nutrition

Organisms are categorized into two groups basing on their source of carbon i.e.

1. **Heterotrophic Nutrition** (*heteros, other; trophos, nourishment*): Where organisms depend on organic nutrients obtained from other organisms due to their inability to manufacture their own. Such organisms have an organic source of carbon and are referred to as **heterotrophs**. This is further categorized into saprophytism, mutualism, commensalism, parasitism and holozoic nutrition
2. **Autotrophic nutrition** (*autos, self; trophos, nourishment*): where organisms make their own organic nutrients from an external supply of relatively simple inorganic raw materials and energy. Such organisms have an inorganic source of carbon, namely carbon dioxide and are referred to as **autotrophs**.

Types of autotrophic nutrition

This is categorized into two groups basing on the source of energy

- (i) **Photosynthesis**: This is the form of nutrition that occurs in all green plants, algae some protists and photosynthetic bacteria (cyanobacteria). It is the process by which organisms synthesize organic compounds sugars, protein and lipids from carbon dioxide and water using sunlight as source of energy and chlorophyll or some other closely related pigment for trapping the light energy.
- (ii) **Chemosynthesis**: this is form of nutrition that occurs in certain bacteria see table below. This is the synthesis of organic compounds from carbon dioxide and water using energy supplied by special methods of respiration involving the oxidation of various inorganic materials such as hydrogen sulphide, ammonia and iron (ii).

Table 1: Examples of chemosynthetic bacteria

Bacteria	Inorganic material	Product	Habitat
1. <i>Nitrosomonas and Nitrococcus</i>	Ammonium (NH ₄ ⁺)	Nitrite (NO ₂ ⁻)	Soil
2. <i>Nitrobacter</i>	Nitrite (NO ₂ ⁻)	Nitrate ((NO ₃ ⁻)	Soil
3. <i>Ferrobacillus / Iron bacteria</i>	Ferrous (Fe ²⁺)	Ferric (Fe ³⁺)	Streams flowing over iron containing rocks
4. <i>Hydrogen bacteria</i>	Hydrogen (H ₂)	Water (H ₂ O)	Soil
5. <i>Colourless Sulphur bacteria</i>	Hydrogen sulphide (H ₂ S)	Water and sulphur	Decaying organic matter

Importance of Photosynthesis

- It is the means by which the sun's energy is captured by plants for use by all organisms.
- It provides a source of complex organic molecules for heterotrophic organisms.

[DOWNLOAD MORE RESOURCES LIKE THIS ON ECOLEBOOKS.COM](http://Ecolebooks.com)

- It releases oxygen for use by aerobic organisms.

THE LEAF AS AN ORGAN OF PHOTOSYNTHESIS

Although stems, sepals and other parts of the plant photosynthesize, the leaf is the main organ for photosynthesis in plants.

Adaptations of plants for photosynthesis (a) Adaptations for obtaining sunlight

- ✦ Phototropism causes shoots to grow towards the light in order to allow the attached leaves to receive maximum illumination.
- ✦ Etiolation causes rapid elongation of shoots which are in the dark, to bring leaves into light to capture light.
- ✦ Mosaic leaf arrangement minimizes leaf overlap and reduces shading of one leaf by another.
- ✦ Broad lamina to provide Larger leaf surface area enabling capturing maximum sunlight.
- ✦ Leaves held at an angle perpendicular to the sun during the day to expose the maximum area to light.
- ✦ Thinness of leaves enables easy penetration of light to lower layers.
- ✦ The cuticle and epidermis are transparent to allow light penetration into the photosynthetic mesophyll beneath.
- ✦ The palisade mesophyll cells are densely packed with chloroplasts and arranged with their long axes perpendicular to the surface to form a continuous layer which traps most of the incoming light.
- ✦ Chloroplasts within the mesophyll cells are capable of moving (**Cyclosis**) allowing them to arrange themselves into the best positions within the cells for efficient absorption of light.
- ✦ The chloroplasts hold chlorophyll in an ordered / structured way on the sides of the grana to present maximum chlorophyll to the light and also bring it close to other pigments / substances necessary for functioning.
- ✦ In leaves of sun plants the palisade layer, whose cells are densely packed with chloroplasts is more than one cell thick to increase on photosynthetic efficiency.
- ✦ In leaves of shade plants, the cells of palisade and spongy mesophylls are densely packed with chloroplasts to increase on light trapping hence photosynthetic efficiency.

(b) Adaptations for obtaining and removing gases

- ✦ Numerous stomata in the epidermis of leaves providing a larger surface area for diffusion of gases.
- ✦ Guard cells bordering stomata pores that open and close stomata to regulate the uptake of carbon dioxide and the loss of water.
- ✦ Numerous airspaces in spongy mesophyll for faster and uninterrupted diffusion of gases between the atmosphere and the palisade mesophyll.

(c) Adaptations for obtaining and removing liquids

- † A large central midrib containing a large vascular bundle comprising xylem and phloem tissue in most dicotyledonous leaves, the xylem for the entry and transport of water and mineral salts, and the phloem for carrying away sugar solution, usually in the form of sucrose.
- † A network of small veins is found throughout the leaf to ensure that every cell is close to xylem vessel or phloem sieve tube for constant supply of water for photosynthesis and a means of removing the sugars they produce.

Assignment

- a) Outline ways in which the structure of a green leaf facilitates photosynthesis
- b) What are the principle functions of leaf veins?

Structure of chloroplast

Is biconvex disc-shaped/ oval shaped, 3 – 10 μm long and 2 – 4 μm wide, enclosed by an envelope of two membranes; the smooth and continuous **outer membrane**, the **inner membrane** gives rise to strands of branching membranes called the **lamellae** extending throughout the organelle. The interior is divided into grana which are surrounded by a, gelatinous semi-fluid called **stroma**. In the grana the lamellae are stacked in piles of flat, circular sacs called **thylakoids**, which contain photosynthetic pigments. In the stroma the thylakoids are criss-cross loosely, suspended in an aqueous matrix containing circular DNA, ribosomes, enzymes used in photosynthesis.

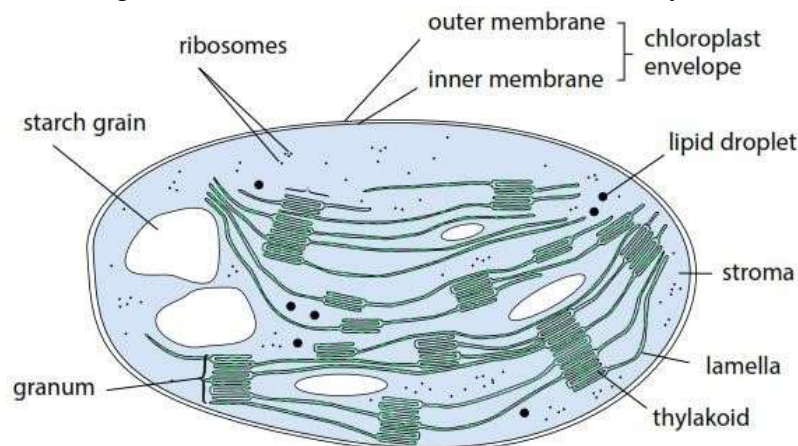

Adaptations of chloroplast for photosynthesis

- † Biconvex shape which increases surface area for exposure of photosynthetic pigments for maximum light absorption.
- † Surrounded by a double membrane to prevent photosynthetic reactions from mixing with those in the cell cytoplasm.
- † The surface membrane is permeable to allow exchange of materials like carbon dioxide which is a raw material for photosynthesis with the cell cytoplasm.

- † The inner membrane is folded inwards to form a system of layers called lamellae to provide a large surface area for attachment of photosynthetic pigments.
- † The internal membrane also contains electron transport systems for synthesis of ATP to drive cell metabolism.
- † It has thylakoids that increase the surface area for holding chlorophyll molecules.
- † The thylakoid granum is connected by intergrana membranes thus maintaining the thylakoids and chlorophyll stationary in position.
- † The stroma contains circular DNA and ribosomes for protein synthesis.
- † The stroma contains a high concentration of the necessary enzymes for catalyzing metabolic reactions occurring within the chloroplast.
- † Thylakoids are flattened discs to provide a small internal volume to maximize hydrogen gradient upon proton accumulation.
- † Thylakoids stacked in piles forming grana to increase the surface area to volume ratio of the thylakoid membrane.
- † Pigments organized into photosystems in thylakoid membranes to maximize light absorption.

THE REQUIREMENTS FOR THE PROCESS OF PHOTOSYNTHESIS

1. Carbon dioxide:

Carbon dioxide is a raw material for photosynthesis and is a source of carbon for the organic compounds produced in the process. Terrestrial plants obtain carbon dioxide: -

- † from the atmosphere (where it's about 0.03%) via the stomata
- † By absorbing carbonates from the soil through the roots, aquatic plants absorb dissolved bicarbonates through their general surface to carbon dioxide.

2. Water

Water is a raw material for photosynthesis. It is a source of hydrogen for reduction of carbon dioxide and also an essential donor of electrons to chlorophyll during non-cyclic phosphorylation which results in production of ATP and NADPH₂ both essential for carbon fixation in the light independent stage.

Water is also essential for the general metabolism of the plant and lack of it to the extent of causing wilting of leaves results in physiological stress on metabolism which in turn affects photosynthesis either directly or indirectly.

Qn . Why is it difficult to demonstrate the importance of water to photosynthesis?

3. Temperature

Photosynthesis proceeds by a series of chemical reactions controlled by enzymes. Suitable temperature is required for activation of enzymes that catalyse photosynthetic reactions.

4. Light

There are three features of light which make it biologically important

[DOWNLOAD MORE RESOURCES LIKE THIS ON ECOLEBOOKS.COM](http://Ecolebooks.com)

1. Spectral quality (color)
2. Intensity (brightness)
3. Duration (time)

To be of use as an energy source for organisms, light must first be converted to chemical energy. Radiant energy comes in discrete packets called quanta. A single quantum of light is called a photon. Light also has a wave nature and so forms a part of the electromagnetic spectrum. Visible light represents that part of this spectrum which has a wavelength between 400nm (violet) and 700 nm (red) see figure 2 below.

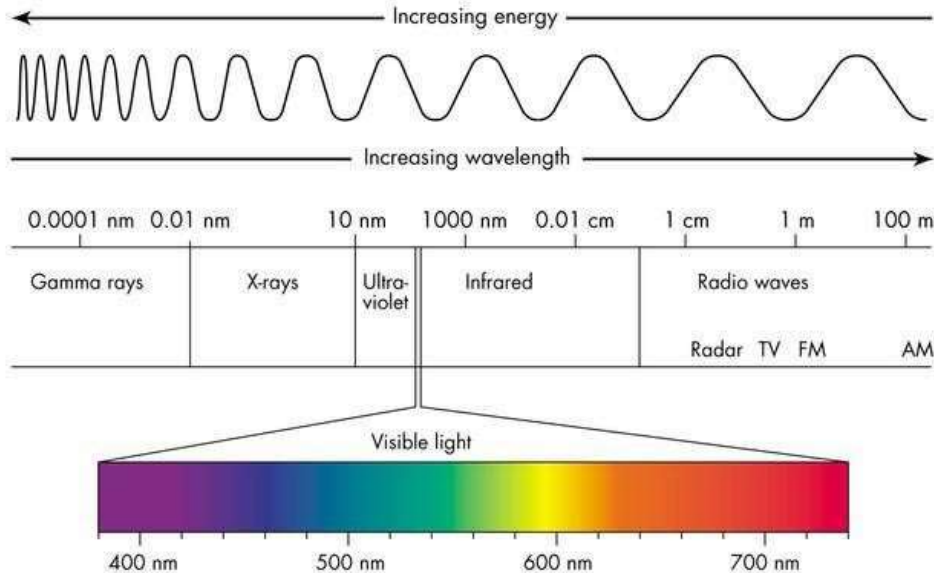

Figure2: The section of the electromagnetic spectrum

As sunlight falls on a plant, some wavelengths are absorbed, while others are reflected or transmitted. The absorbed light provides energy that excites electrons in the photosystems whose transition releases energy for synthesis of ATP, also light is necessary for photolysis of water to release electrons stabilizing photosystems and hydrogen atoms forming NADPH_2 for reduction of carbon dioxide.

5. Pigments

Photosynthetic pigments of higher plants are categorized into two groups i.e. chlorophylls and carotenoids. The algae in addition have phycobiliproteins like phycocyanin (blue) and phycoerythrin (red). The role of the pigments is to absorb light energy, thereby converting it into chemical energy. They are located on chloroplast membranes (thylakoids) and the chloroplasts are usually arranged within the cells so that the membranes are at right angles to the light source for maximum light absorption (a) **Chlorophylls**

There are several types of chlorophyll, all containing a ring structure called porphyrin ring with magnesium at the center linked to a long hydrocarbon chain (figure 3)

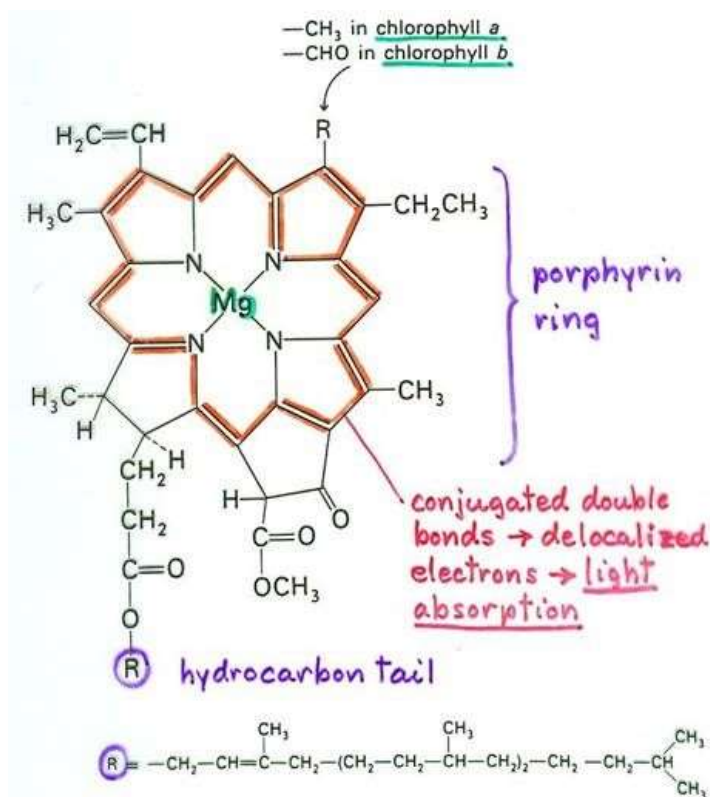

The most common chlorophylls include chlorophyll a, chlorophyll b, some photosynthetic bacteria have another type of chlorophyll called bacteriochlorophyll, which contains manganese instead of magnesium. Chlorophylls absorb light in the blueviolet and the red region of the visible spectrum. The remaining light, in the green region of the spectrum, is reflected and gives chlorophyll its characteristic color.

Figure 3: Structure of chlorophyll

molecule

(b) Carotenoids

Carotenoids are yellow, orange, red or brown pigments they absorb strongly in the blue-violet range of the spectrum.

Roles of carotenoids

- † They are accessory pigments; they absorb light energy and pass the light they absorb on to chlorophyll.
- † They protect chlorophylls from excess light and from oxidation by oxygen produced in photosynthesis.

Carotenoids are of two types, carotenes and xanthophylls, these are usually masked by the green chlorophylls but can be seen in leaves before leaf-fall because chlorophylls break down first. A common example of a carotene is β -carotene which gives carrots their familiar orange color. It is easily formed into two molecules of vitamin A.

Absorption and action spectra

If a pigment such as chlorophyll is subjected to different wavelength of light, it absorbs some more than others. If the degree of absorption at each wavelength is plotted, an absorption spectrum of that pigment is obtained (**figure 4**).

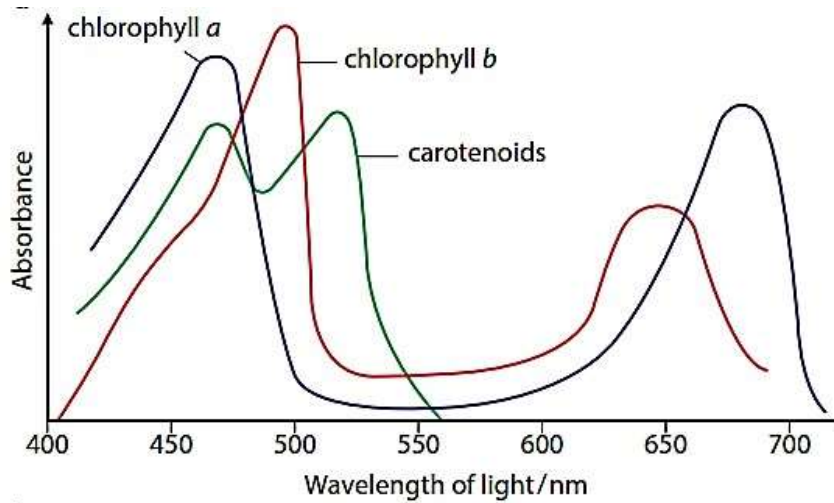

Figure 4: Absorption spectrum of chlorophylls and carotenoids

An **absorption spectrum** is a graph of the relative amounts of light absorbed at different wavelengths of light by a pigment.

An **action spectrum** is a graph showing the effectiveness of different wavelengths of light in stimulating the process being investigated. **Figure 5** below shows an action spectrum for photosynthesis together with an absorption spectrum for combined photosynthetic pigments.

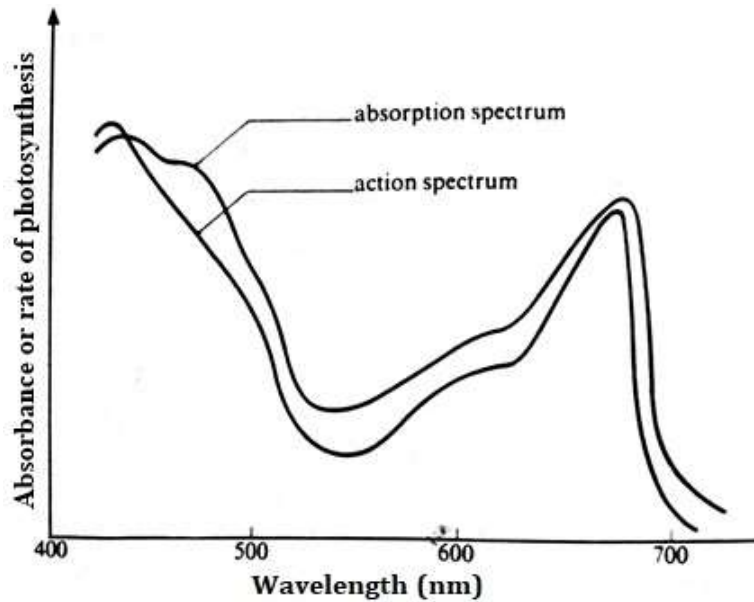

Figure 5: Action spectrum for photosynthesis compared with absorption spectrum of photosynthetic pigments.

From **figure 5** above: -

- ✦ the red and blue ends are the most effective wavelengths in photosynthesis; ✦ green is only used to a slight extent.

- ✦ There is a close correlation between the absorption and action spectrum, indicating that the pigments, chlorophylls in particular, are responsible for the absorption of light used in photosynthesis.
- ✦ The non-correspondence in the two spectra between about 450nm and 470nm, is because this wavelength is absorbed by carotenes which are not used in photosynthesis.

Assignment: Explain the similarities and differences between the absorption and action spectra in figure 5 above.

Discovery of the role of red and blue light in photosynthesis

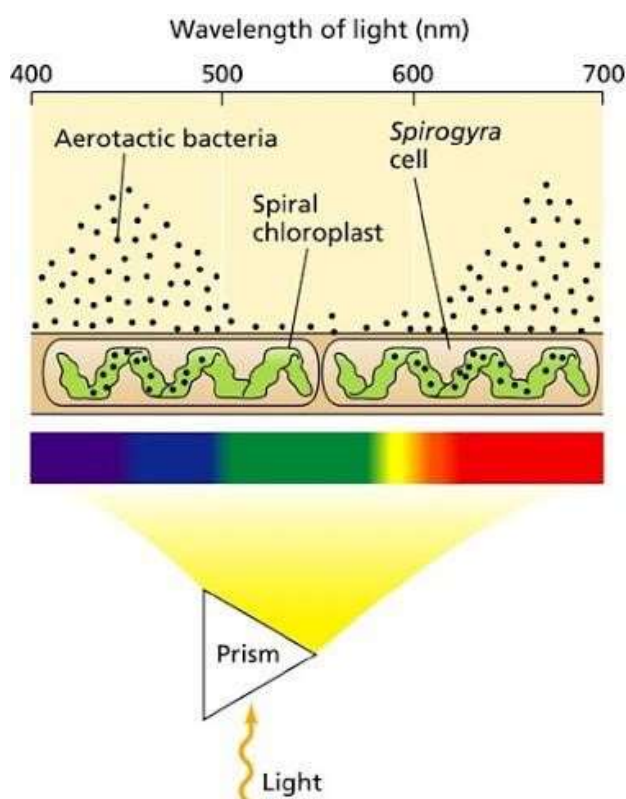

In an investigation Engelman, used a species of motile aquatic aerobic bacterium. Where these bacteria are found to accumulate, he knew that oxygen was also present.

Engelman split sunlight into its constituent colors by means of a prism, and projected them onto cells so that the different colors of light were received by different parts of the filament. The aerobic bacteria in the water collected around the filaments in areas where the chloroplast was receiving red and blue light.

Conclusion

Light in the violet-blue and red portions of the spectrum is most effective in driving photosynthesis.

Figure 6: results of Engelmann's experiment

MECHANISM OF PHOTOSYNTHESIS

The overall equation for photosynthesis is:

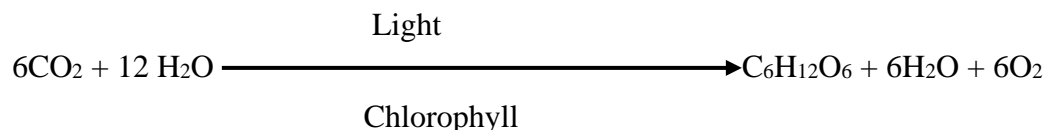

Photosynthesis is essentially a process of energy transduction. Light energy is first converted into electrical energy and then into chemical energy in three main phases i.e.

1. **Light harvesting.** Light energy is captured by the plant using a mixture of pigments including chlorophyll.

[DOWNLOAD MORE RESOURCES LIKE THIS ON ECOLEBOOKS.COM](http://Ecolebooks.com)

2. **Light dependent stage (photolysis)** in which a flow of electrons results from the effect of light on chlorophyll and so causes the splitting of water into hydrogen ions and oxygen
3. **The light independent stage** during which these hydrogen ions are used in the reduction of carbon dioxide and hence the manufacture of sugars.

LIGHT HARVESTING

The photosynthetic pigment molecules are clustered in the thylakoid membranes. Each cluster is called an **antenna complex**

Special proteins associated with these pigments channel light energy entering the chloroplast on to special molecules of chlorophyll a, known as the reaction **center chlorophyll molecule**. The reaction Centre and all the other light-gathering molecules combine to form a **photosystem**.

When light strikes this molecule, an electron in its orbit is raised to a higher energy level, thus initiating a flow of electrons.

There are two types of photosystems; **photosystem I** and **photosystem II**.

In photosystem I, the reaction Centre is called **P700** because its chlorophyll a has a maximum absorption at a wavelength of **700nm** (red light).

Photosystem II has a reaction Centre called **P680** because its chlorophyll a has a maximum absorption at **680nm** (orange-red).

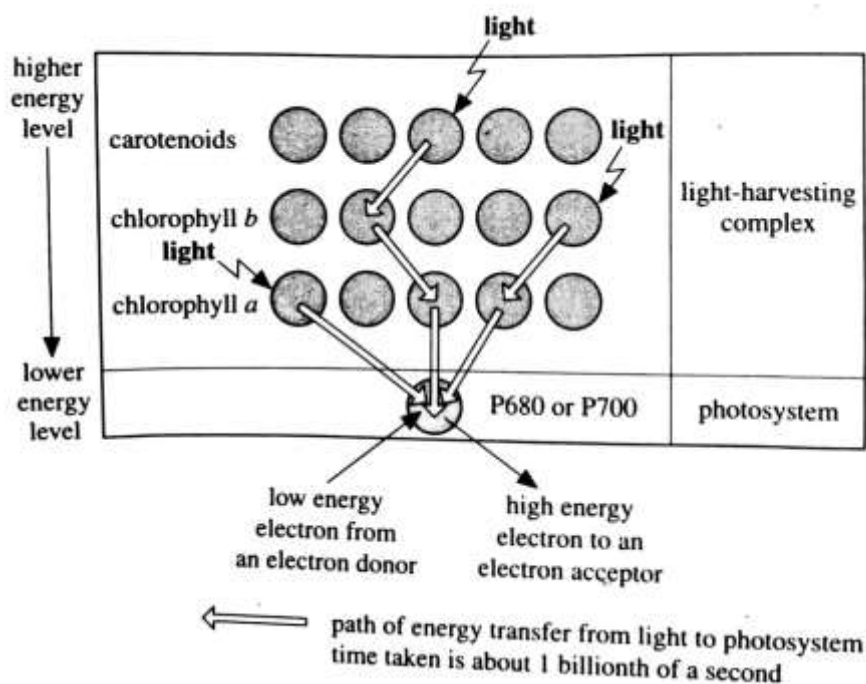

Figure 7: A photosystem: a light-harvesting cluster of photosynthetic pigments in chloroplast thylakoid membrane

Exercise 1

1. (a) Explain how a photosystem increases the light harvesting ability of a chloroplast?
- (b) Explain the relationship between the action spectrum and the absorption spectrum of photosynthetic pigments in green plants.

Evidence that photosynthesis is a two-stage process

- (i) The overall process is influenced by increase in temperature which would not be the case if it was dependent on light alone.
- (ii) The amount of carbohydrate produced in a given quantity of light is greater if the light is supplied intermittently/in flashes rather than continuously suggesting that some part of photosynthesis is independent of light.
- (iii) By use of radioactive tracers like C^{14} in $C^{14}O_2$ which have subsequently been detected in the organic compounds produced. It has been shown that the reduction of carbon dioxide can occur in the absence of light.

THE LIGHT-DEPENDENT STAGE

How light trapped by chlorophyll is used

1. Provides energy to convert ADP and an inorganic phosphate (Pi) to ATP a process called **photophosphorylation**
2. Necessary for the splitting of water molecules to release electrons and hydrogen ions a process known as **photolysis**.

Importance of light dependent stage of photosynthesis

1. produces Adenosine triphosphate (ATP) which is a source of energy for subsequent synthesis of carbohydrates.
2. Photolysis of water produces hydrogen atoms for the reduction of carbon dioxide during the dark stage.

The light dependent reactions of photosynthesis

The light-dependent reactions occur in the **thylakoid membranes** of a chloroplast's **grana**. It involves the splitting of water by light (**photolysis of water**) to give hydrogen ions (protons) and the synthesis of ATP in **photophosphorylation**. The hydrogen ions combine with a carrier molecule NADP to make reduced NADP. ATP and reduced NADP are passed from the light dependent to the light independent reactions.

Photophosphorylation of ADP to ATP can be cyclic or non-cyclic, depending on the pattern of electron flow in one or both types of photosystem. (i) **Cyclic photophosphorylation**

Cyclic photophosphorylation involves only **photosystem I**. Light of wave length 700nm is absorbed by photosystem I (P700) and is passed to the primary pigment. An electron in the chlorophyll molecule is excited to a higher energy level and is emitted from the chlorophyll molecule. This is called **photoactivation**. Instead of falling back into the photosystem and losing its energy as thermal energy or as fluorescence, the excited electron is captured by an electron acceptor and passed back to a chlorophyll molecule via a chain of electron carriers i.e.

ironprotein complex, to cytochromes b, to plastoquinone, to cytochrome-f, to plastocyanin and again back to P-700.

The flow of electrons through carriers in the thylakoid membrane releases energy for active pumping of hydrogen ions (H^+) from the stroma to the thylakoid space.

The highly concentrated H^+ inside the thylakoid space **diffuse** along the steep electrochemical gradient from the thylakoid space via the stalked particles into the stroma, thereby providing energy to form ATP in the presence of ATPase enzyme. this process is called chemiosmosis. The ATP then passes to the light independent reactions.

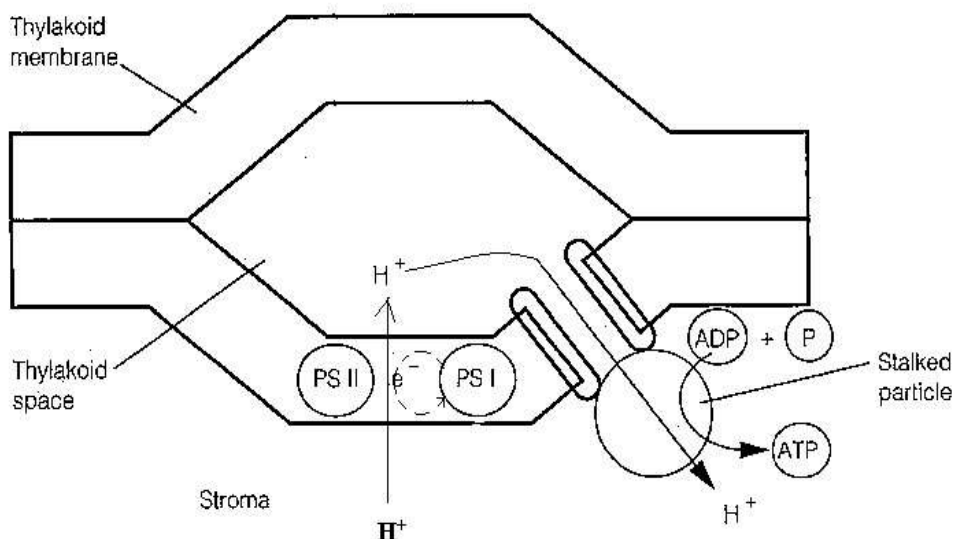

Figure 8: Summary of events that occur during cyclic photophosphorylation

(ii) **Non-cyclic photophosphorylation**

Non-cyclic photophosphorylation involves both photosystems I and II in the so-called 'Z scheme' of electron flow (unidirectional electron flow) (Figure 9).

Light strikes both photosystems I and II simultaneously, excited electrons are emitted from the primary pigments of both reaction centres. These electrons are absorbed by electron acceptors and pass along chains of electron carriers, leaving the photosystems positively charged. The electrons from photosystem II are passed from the electron acceptor along a series of electron carriers to photosystem I. The primary pigment at photosystem II receives replacement electrons from the splitting (photolysis) of water.

Photosystem II includes a water-splitting enzyme that catalyses' the breakdown of water:



Oxygen is a waste product of this process. The hydrogen ions combine with electrons from photosystem I and the carrier molecule NADP to give reduced NADP.

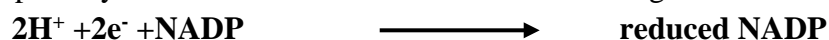

Reduced NADP passes to the light independent reactions and is used in the synthesis of carbohydrate.

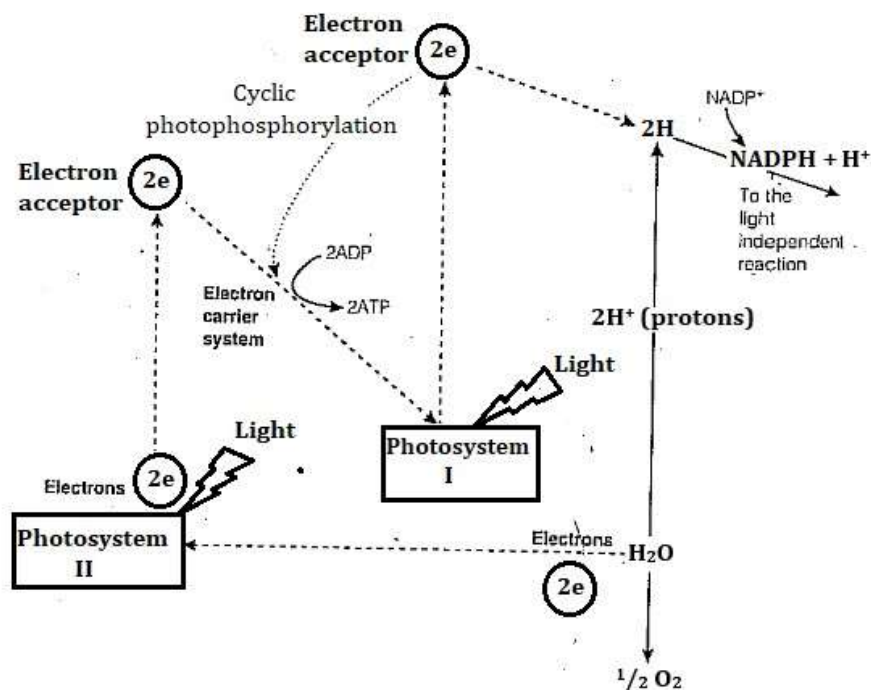

Figure 9: The Z-Scheme

As in cyclic photophosphorylation, ATP is synthesized as the electrons lose energy while passing along the carrier chain.

The movement of electrons in the thylakoid membranes releases energy which enables active pumping of hydrogen ions (H^+) from the stroma to the thylakoid space. At the same time, photolysis of water

- (i) causes accumulation of H^+ **inside the thylakoid space**
- (ii) provides electrons to replace those lost from PSII.

The high accumulation of H^+ photolysis and active pumping of proton creates a steep electrochemical gradient between the thylakoid space and stroma, resulting in **diffusion** of H^+ via the stalked particles into the stroma this provides

- (i) energy to form ATP in the presence of ATPase enzyme
- (ii) H^+ for reducing NADP to form NADPH.

The NADPH and ATP formed then enter the dark stage.

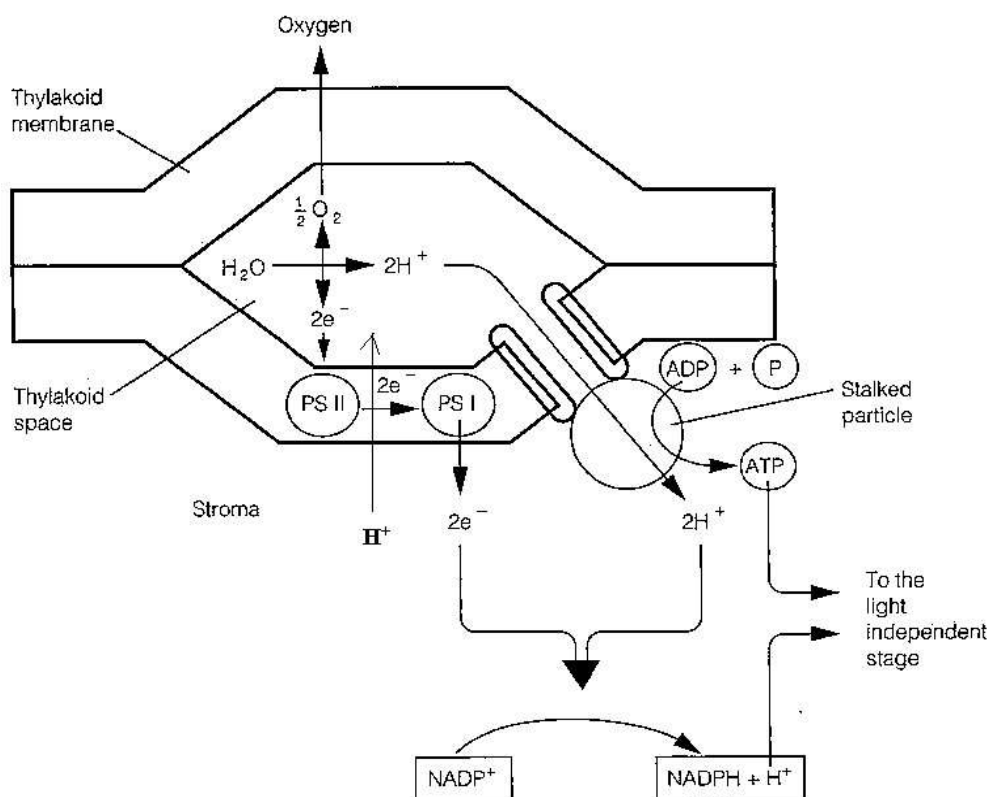

Figure 10: Summary of events that occur during non-cyclic photophosphorylation

COMPARISON BETWEEN CYCLIC AND NON-CYCLIC PHOTOPHORYLATION

Similarities

In both

- ✦ there is flow of electrons through electron carriers ✦ there are pigment systems which accept and lose electrons.
- ✦ ATP is formed.
- ✦ pigment system I is involved
- ✦ electron movement is located in the thylakoid membranes ✦ protons are moved outwards of the thylakoids.
- ✦ protons (H^+) are actively pumped from stroma into thylakoid space.
- ✦ there is photo-excitation of electrons in the pigment systems.

Differences

Non-cyclic photophosphorylation	Cyclic photophosphorylation
✦ Electrons flow unidirectionally (noncyclically)	✦ Electrons flow in a cyclic pattern
✦ First electron donor is (source of electrons) water	✦ First electron donor is photosystem I

✦ Last electron acceptor is NADP	✦ Last electron acceptor is photosystem I
✦ The products are ATP, NADPH and Oxygen	✦ The product is only ATP.
✦ Involves both photosystems I and II	✦ Involves only photosystems I
✦ Photolysis of water occurs	✦ No photolysis of water
✦ Two electron acceptors involved	✦ Only one electron acceptor involved

Note

- ✦ During cyclic photophosphorylation no oxygen and NADPH produced as photolysis of water does occur,
- ✦ Relatively less energy is produced in cyclic photophosphorylation than in non-cyclic photophosphorylation since non-cyclic photophosphorylation involves two photosystems of which each takes up a quantum of light.
- ✦ When carbon dioxide concentration is limiting, both photosystems cannot operate at the same time hence only photosystem I operates and photophosphorylation is mainly cyclic.

THE LIGHT-INDEPENDENT STAGE

This also referred to as the dark stage because the reactions can take place in the dark if sufficient ATP and NADPH are available. It occurs in the stroma of the chloroplast and takes place whether or not light is present. The reactions are controlled by enzymes and their sequence was determined by Melvin Calvin, Benson and Bassham during a period of 1946-53. The process is often called the **Calvin cycle**.

The dark reactions involve main pathways which include

- ✦ Calvin-Benson cycle / C₃ pathway
- ✦ Hatch-Slack pathway / C₄ pathway

1. Calvin-Benson cycle / C₃ pathway

This is the series of reactions in plants involving formation of glycerate-3-phosphate which has 3 carbon atoms as first stable organic substance during photosynthesis.

MAIN STAGES OF C₃ PATHWAY**1. Carboxylation**

Carbon dioxide diffuse into the stroma and then combines with a 5-carbon sugar, **Ribulose biphosphate** (RUBP), in a reaction catalysed by enzyme RuBP carboxylase (Rubisco), the resulting 6 carbon compound is unstable and immediately breaks down to form two molecules of 3-carbon compound known as 3-phosphoglyceric acid (PGA)/ glycerate-3-phosphate (GP), which is the **first stable organic compound in C₃ plants**.

2. Reduction phase

3-phosphoglyceric acid (PGA) molecules are phosphorylated by ATP from the light stage ADP, and then reduced by NADPH (formed in light stage) to form a **triose phosphate (TP)** called 3phosphoglyceraldehyde (PGAL) or glyceraldehyde-3-phosphate(GALP), which is a 3-carbon sugar, **NADP⁺**, ADP and an inorganic phosphate (Pi).

Note:

Triose phosphate is the first stable carbohydrate formed in the Calvin cycle.

[DOWNLOAD MORE RESOURCES LIKE THIS ON ECOLEBOOKS.COM](http://Ecolebooks.com)

NADP⁺ is regenerated and this returns to the light dependent stage to accept more hydrogen

3. Regeneration phase

Five-sixth of the triose phosphates are converted through a series of reactions into RUBP which then fixes more carbon dioxide. This reaction requires both ATP and NADPH from the light stage.

4. Product synthesis phase

One-sixth of the triose phosphate molecules are used to produce other molecules needed by the plant. Some of these triose phosphates condense to become hexose phosphates which, in turn, are used to produce starch for storage, sucrose for translocation around the plant, or cellulose for making cell walls. Others are converted to glycerol and fatty acids to produce lipids for cellular membranes or to acetyl coenzyme A for use in respiration or in the production of amino acids for protein synthesis.

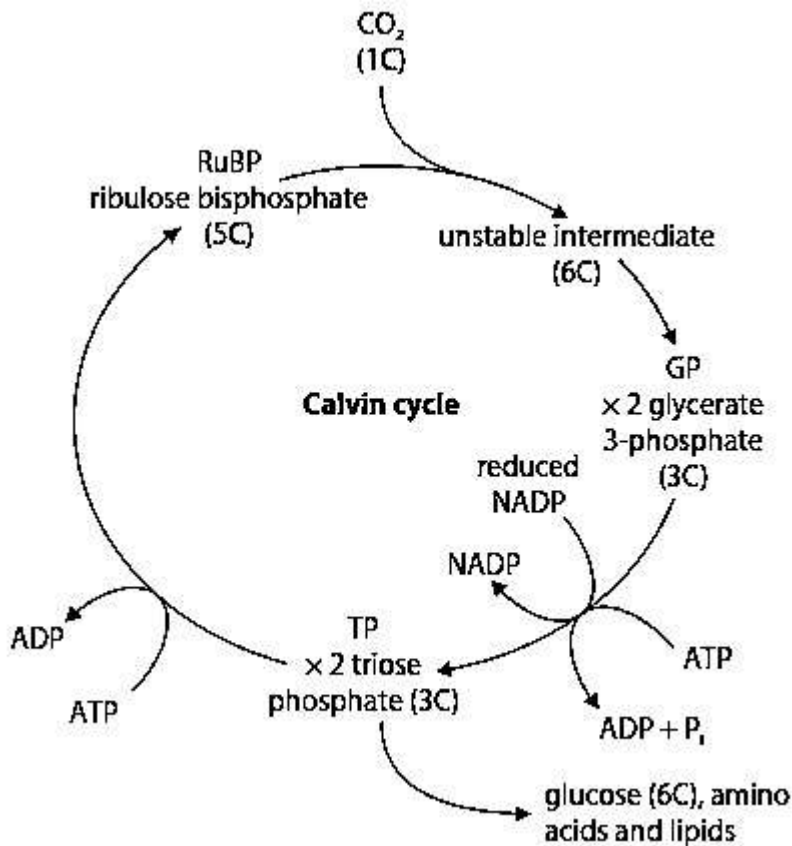

Figure 11: the Calvin cycle

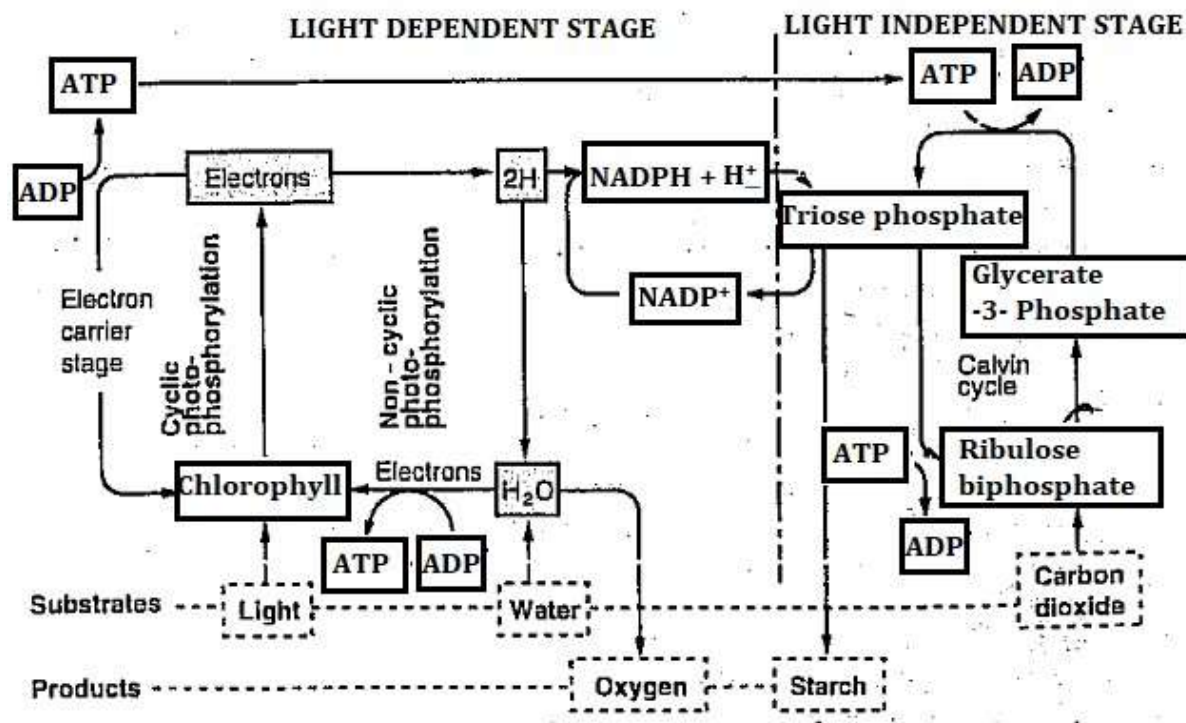

Figure 12: Summary of process of photosynthesis

Exercise 2

- Outline the light-independent reactions of photosynthesis.
 - Explain:
 - why the light-independent reactions of photosynthesis can only continue for a short time in darkness.
 - how the light-independent reactions of photosynthesis rely on light-dependent reactions.
- Outline the formation of carbohydrate molecules in photosynthesis starting from the absorption of light energy
 - Compare the structure of a chloroplast and a mitochondrion in relation to function.
- Explain photophosphorylation in terms of chemiosmosis in chloroplast.
 - Explain the reactions involving the use of light energy that occur in the thylakoids of the chloroplast.

4. Experiments on cultures of a unicellular protist to investigate the effect of light and carbon dioxide on certain metabolites. In the first experiment, the levels of PGA, RuBP and sucrose in the protist were determined at different time intervals in the presence of light. At the 35th minute, light was switched off, suddenly putting the protists in darkness; the results are shown in the table below

Time (minutes)		0	20	35	40	50	60	70
Amount of metabolite	RuBP	35	35	35	30	15	10	10
	PGA	45	45	45	50	65	70	70
	Sucrose	10	54	72	66	52	35	20

- (a) Represent the data provided graphically
- (b) Using the graph obtained in (a) above, explain the variation in the levels of the metabolites with time
5. In an experiment, samples of algae were collected at 1-minute intervals over a period of 5 minutes. The quantities of glycerate-3-phosphate (GP) and ribulose biphosphate (RuBP) were measured. At the beginning of the experiment, the concentration of carbon dioxide supplied was high. After 2 minutes, the concentration of carbon dioxide was reduced. The graph in the figure below shows the results of this experiment.

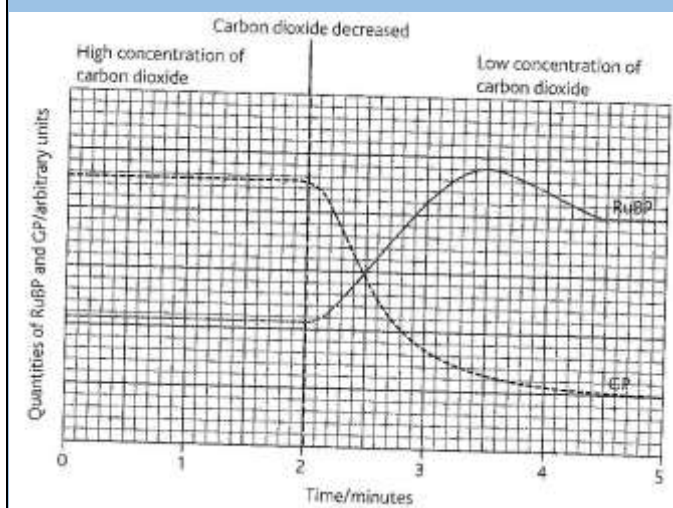

- (a) Describe the effects of the decrease in carbon dioxide after 2 minutes on:

(i) Glycerate 3-phosphate (GP)

- (ii) Ribulose biphosphate (RuBP)
- (b) Suggest explanation for these changes to the levels of glycerate 3-phosphate (GP) and RuBP.

Metabolism of Glycerate phosphate (GP) and Glyceraldehyde phosphate (TP/ PGAL)

(a) *Synthesis of carbohydrates*

Glyceraldehyde-phosphate molecules are converted to form monosaccharides e.g. glucose. Glucose may combine with fructose to form sucrose, transported in phloem sieve tubes or can be polymerized into starch for storage or cellulose; a component of plant cell walls.

(b) *Synthesis of lipids*

- Glycerate-phosphate enters glycolysis pathway and is converted to pyruvate, which can be converted into acetyl group, which combines with coenzyme A to form acetyl coenzyme A.

This can be used to form a variety of fatty acids in the cytoplasm and chloroplast.

- Glycerate-phosphate can also be converted to glycerol

Lipids such as triglycerides are esters of fatty acids and glycerol, which are important components of cell membranes. (c) **Synthesis of proteins**

Glycerate-phosphate is converted into acetyl coenzyme A and enters into the Krebs cycle. Some of its intermediates can produce different amino acids by transamination reactions. The amino acids are then polymerized into proteins which are required for growth and development, synthesis of enzymes and structural components of the cell.

NB:

The nitrogen, Sulphur and phosphorus required for protein synthesis are absorbed from the soil. Nitrogen is taken up as nitrates or ammonia, Sulphur as sulphates and phosphorus as phosphates.

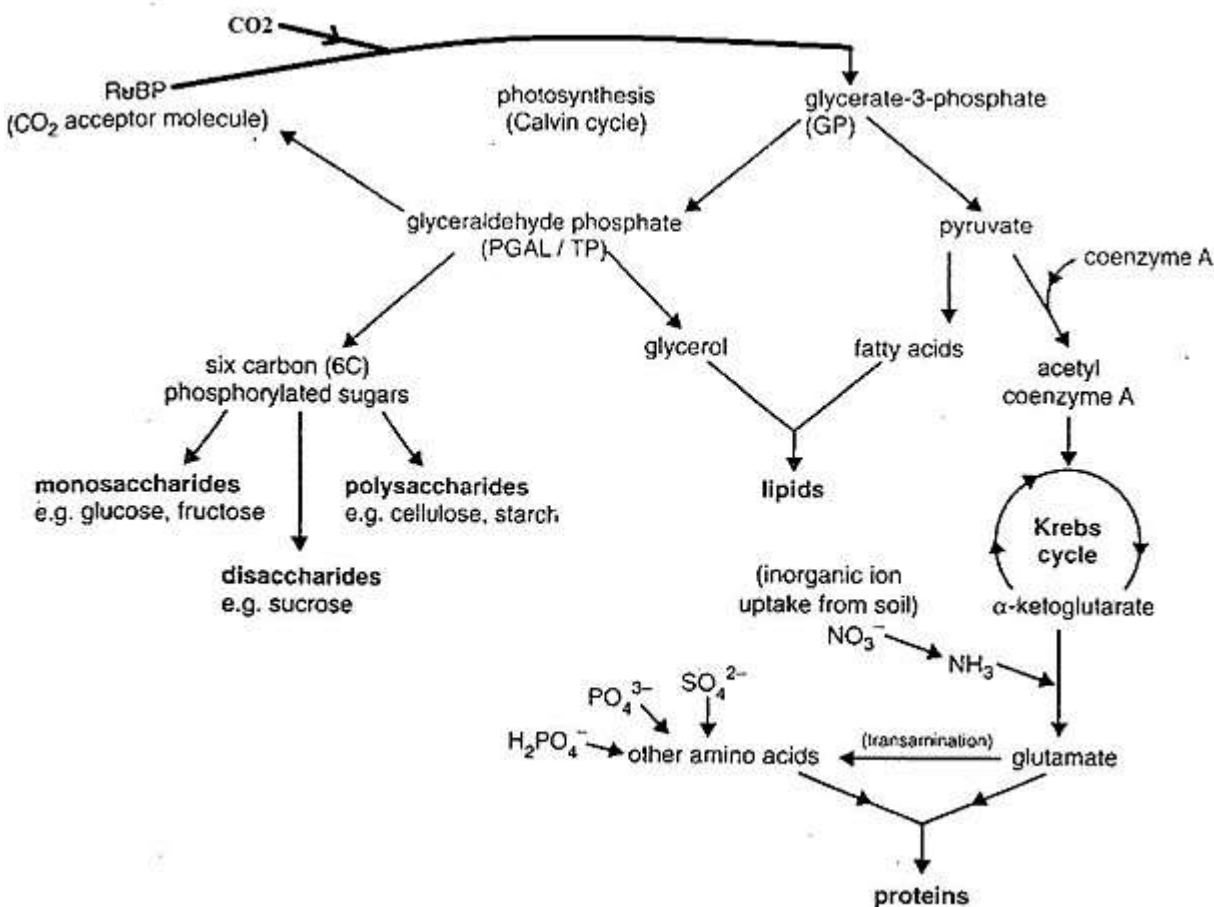

Figure 13: Summary of metabolism of intermediates of dark stage

Assignment: Compare light dependent and light independent stages of photosynthesis

NOTE

- ✦ The enzyme Ribulose biphosphate carboxylase that catalyses the reaction of carbon dioxide with RuBP unfortunately, it can also catalyse the reaction of oxygen with RuBP. When this happens, less photosynthesis takes place, because some of the RuBP is being ‘wasted’ and less is available to combine with carbon dioxide. This unwanted reaction is known as **photorespiration**. It happens most readily in high temperatures and high light intensity – that is, conditions that are found at low altitudes in tropical parts of the world.
- ✦ Photorespiration is a wasteful process in which carbon fixation in C₃ plants is prevented due to the light dependent uptake of oxygen by RuBP carboxylase (RUBISCO enzyme) and release of carbon dioxide
- ✦ Tropical grasses such as maize, sorghum and sugar cane which are C₄ plants have evolved a method of avoiding photorespiration. They keep RuBP and rubisco well away from high oxygen concentrations. The cells that contain RuBP and rubisco are arranged around the vascular bundles, and are called **bundle sheath cells** the arrangement known as the **Kranz anatomy**. They have no direct contact with the air inside the leaf.

2. HATCH-SLACK PATHWAY OR C₄ METABOLISM

This is a type of photosynthesis in which CO₂ is first, fixed by phosphoenolpyruvate carboxylase (PEPCO) into Oxaloacetate (OAA) inside mesophyll cells, stored as organic acid (mainly malate) which is **later** decarboxylated, refixed and CO₂ is assimilated in the Calvin-cycle inside bundle sheath cells.

Examples of C₄ plants: maize, sorghum, *Amaranthus*, *Sugar cane*, paspalums (*Paspalum notatum*), Bermuda grass, blue grama, Rhodes grass, troublesome weeds like nut grass, crabgrass and barnyard. They are found mainly in hot / arid / saline tropical habitats.

WHAT IS KRANZ LEAF ANATOMY?

A condition in which bundle sheath cells and palisade cells of the mesophyll form two concentric layers (rings) around each vascular bundle of leaves.

COMPARISON OF LEAF ANATOMY IN C_3 AND KRA NZ ANATOMY IN C_4 PLANTS

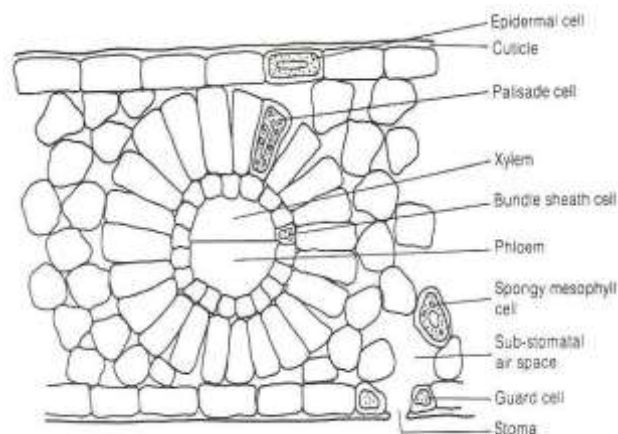
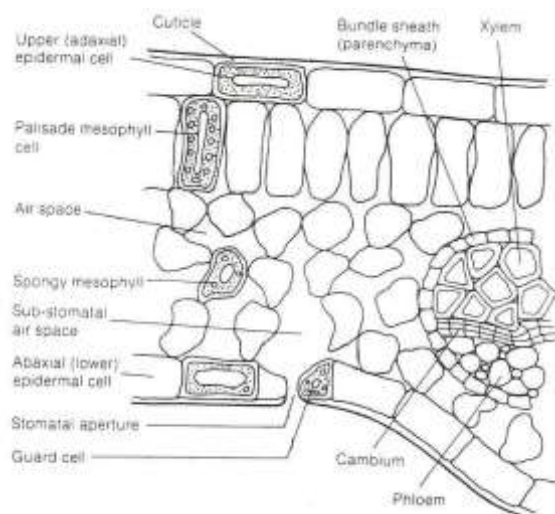

This is a pathway for transporting carbon dioxide and hydrogen from mesophyll cells to bundle sheath cells. Once in the bundle sheath cells, the carbon dioxide is released again and normal C_3 photosynthesis occurs. **Stages in C_4 pathway**

1. acceptance of carbon dioxide (carbon dioxide fixation) in mesophyll cells In the presence of phosphoenol pyruvate carboxylase (PEPCO) enzyme, the carbon dioxide acceptor with 3 carbon atoms, phosphoenol pyruvate (PEP) combines with carbon dioxide inside the chloroplasts of mesophyll cells to form oxaloacetate (OAA) a 4-carbon compound. This is the first stable compound formed in C_4 plants. Oxaloacetate is reduced by NADPH from the light stage to malate a 4-carbon acid. This occurs in the presence of malate dehydrogenase enzyme.

2. Malate shunt

From chloroplasts of mesophyll cells, the malate is translocated (shunted) to the chloroplasts of bundle sheath cells where it is decarboxylated and dehydrogenated by NADP to form pyruvate a 3-carbon acid and carbon dioxide. The pyruvate produced returns to mesophyll cells for phosphorylation by ATP to regenerate **PEP**; the CO_2 acceptor.

Now the second carboxylation occurs in the chloroplasts of bundle sheath cells through Calvin cycle.

3. Regeneration of the carbon dioxide acceptor

Pyruvate is returned to the mesophyll cells and is used to regenerate PEP by the addition of phosphate from ATP. This requires the energy from two high energy phosphate bonds.

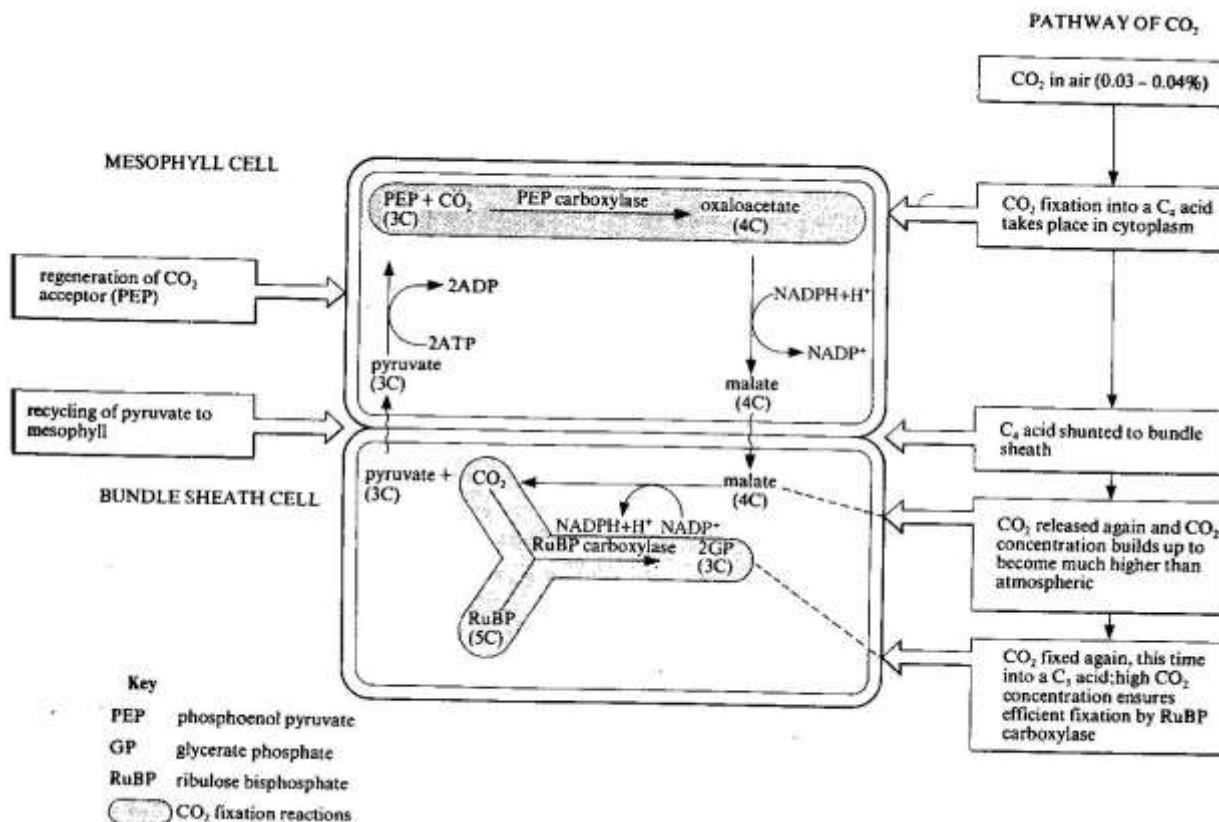

Figure 14: Summary of Hatch-slack pathway

ADVANTAGES OF HATCH_SLACK PATHWAY

- † C₄ plants ably photosynthesize at very low CO₂ concentration (e.g. in dense tropical vegetation) because PEP carboxylase enzyme has a very high affinity for carbon dioxide.
- † Concentric arrangement of mesophyll cell produces a smaller area in relation to volume for better utilization of available water and reduce, the intensity of solar radiations.
- † **Photorespiration**, which inhibits growth in C₃ plants is **avoided / reduced** in C₄ because
 - ✦ the CO₂ fixing enzyme PEP carboxylase has no affinity for oxygen
 - ✦ RUBISCO enzyme inside the bundle sheath cells is shielded from high oxygen concentration by the ring of palisade cells.
- † The CO₂ fixing enzymes in C₄ plants are more active at hot temperature and high illumination, therefore photosynthesis occurs rapidly at low altitude, hot and brightly lit tropical conditions than in C₃ plants.
- † The productivity of C₄ almost **four times** greater than in C₃ **because:**
 - (i) of the increased rate of CO₂ uptake caused by
 - ✦ large internal leaf surface area
 - ✦ short CO₂ diffusion distance

- (ii) CO₂ steep diffusion gradients in the bundle sheath cells in which dark reactions occur have
- ✦ a large photosynthetic surface area enabled by un-usually large chloroplasts
 - ✦ lack of grana on which O₂ would be produced, so ***no photorespiration***.
 - ✦ the Palisade cells in which light reactions occur have large grana to increase the photosynthetic surface area.

Disadvantages of hatch-slack pathway

- ✦ The CO₂ fixing enzymes in C₄ plants are less active at cool temperature and low illumination, therefore photosynthesis occurs slowly at high altitude with cool temperature and in low light intensity of temperate conditions.
- ✦ Since every carbon dioxide molecule has had to be fixed twice, the energy requirements for C₄ photosynthesis is roughly double that for C₃ photosynthesis.

COMPARISON BETWEEN C₃ AND C₄ PLANTS

Similarities Both:

- ✦ contain RUBISCO enzyme
- ✦ depend on light for their reactions
- ✦ show CO₂ fixation
- ✦ have RuBP
- ✦ form several same organic products e.g. PG, PGA, sucrose
- ✦ have the Calvin cycle

Differences

C ₃ Plants	C ₄ plants
○ Lack Kranz anatomy	○ Exhibit Kranz anatomy
○ All chloroplasts have identical structure	○ Chloroplasts are dimorphic (are in two forms) e.g. those of palisade cells have grana yet are lacking bundle sheath cells.
○ CO ₂ acceptor is a 5-Carbon RuBP	○ CO ₂ acceptor is a 3-Carbon PEP
○ CO ₂ fixation occurs once	○ CO ₂ fixation occurs twice
○ Photorespiration occurs	○ No photorespiration
○ Less photosynthetically efficient	○ More photosynthetically efficient
○ GP is the first organic product	○ OAA is the first organic product
○ Enzymes are more efficient at lower temperatures	○ Enzymes are more efficient at high temperatures
○ RUBISCO enzyme is used	○ PEP carboxylase enzyme is used

<ul style="list-style-type: none"> ○ Compensation point is attained at higher CO₂ concentration 	<ul style="list-style-type: none"> ○ Compensation point is attained at lower CO₂ concentration
---	--

CRASSULACEAN ACID METABOLISM (CAM) PHOTOSYNTHESIS

This is a type of photosynthesis in which CO₂ is taken in at night via open stomata, fixed by phosphoenolpyruvate carboxylase (PEPC) into OAA, stored as organic acid (mainly malate) which is **later** decarboxylated during daytime, refixed and CO₂ is assimilated in the Calvin-cycle when stomata are closed.

Examples of CAM plants

Cacti, agaves (sisal), opuntia, *Kalanchoe* (*Bryophyllum*), Vanilla (family: Orchidaceae), pineapples (Family: *Bromeliaceae*), Mesembryanthemum crystallinum (Common ice plant), and *Euphorbia milii* (Crown of Thorns plant). These are mainly succulent plants that live in hot arid climates.

When the stomata open at night, carbon dioxide enters the leaves and combines with PEP to form OAA in the presence of an enzyme PEPCO found in their cytoplasm. The OAA is then reduced to malate a reaction catalysed by an enzyme malic dehydrogenase which accumulates in the leaf vacuoles.

During the day when the stomata are closed the malate is transported to the cytoplasm where it is decarboxylated to pyruvate and carbon dioxide, the carbon dioxide released enters the chloroplast where it is fixed to sugars in the Calvin cycle.

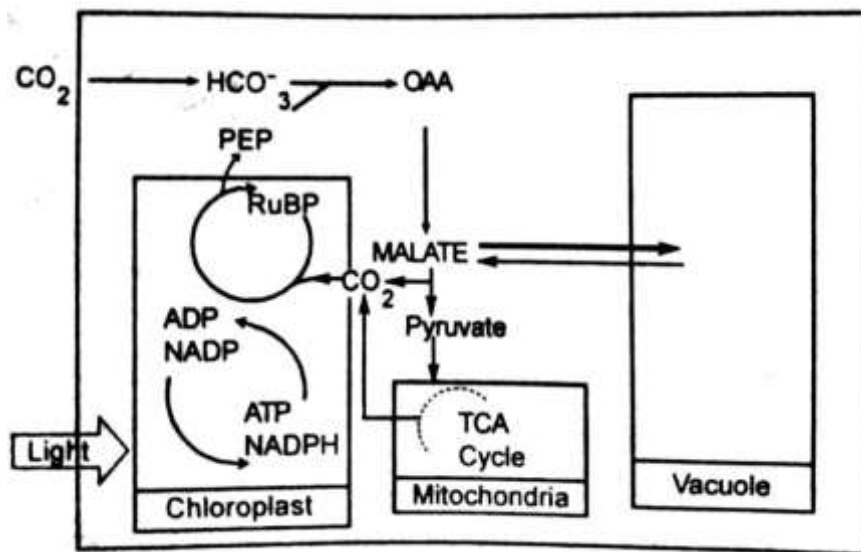

Figure 15: A representation of the CAM cycle Assignment: State the differences between metabolism in C₄ plants and CAM plants Exercise 3

- | |
|--|
| <p>1. (a) Distinguish between light compensation point and compensation period (02 marks)</p> <p>(b) (i) Explain why C₃ plants have a higher carbon dioxide compensation point compared to the C₄ plants. (02 marks)</p> <p>(ii) Suggest the physiological advantages of C₄ having low carbon dioxide compensation point compared to C₃ plants. (03 marks)</p> <p>(c) State any three differences between the mesophyll and bundle sheath chloroplasts in C₄ plants. (03 marks)</p> |
| <p>2. (a) What is meant by the term C₄ plant? (02 marks)</p> <p>(b) (i) explain the significance of C₄ plants for being more efficient at carbon dioxide fixation than C₃ plants. (06 marks)</p> <p>(ii) Explain how carbon dioxide is fixed by C₄ plants. (06 marks)</p> <p>(c) How are leaves of C₄ plants modified to suit it for carbon dioxide fixation? (06 marks)</p> |

Significance of CAM photosynthesis

For terrestrial CAM plants, there is increased water use efficiency in which nocturnal stomatal opening greatly reduces stomatal loss of water as it would in day light.

Note

- ✦ CAM is an adaptation for hot and dry conditions. It enables the plant to conserve water by keeping stomata closed in the heat of the day when transpiration would be most rapid
- ✦ CAM plants are extremely efficient at conserving water but unfortunately their rate of net photosynthesis per unit area of plant or ground is very low and correspondingly their growth rates are also very low.

MEASUREMENT OF THE RATE OF PHOTOSYNTHESIS

Rate of photosynthesis can be measured by measuring the rate of:- ✦

uptake of CO₂

✦ production of O₂

✦ production of carbohydrates

✦ increase in dry mass

(a) Measuring the rate of Uptake of CO₂

Uptake of CO₂ can be measured with the means of an IRGA (Infra-Red Gas Analyser) which can compare the CO₂ concentration in gas passing into a chamber surrounding a leaf / plant and the CO₂ leaving the chamber. **The soil and roots must NOT be in the bag to avoid CO₂ production from respiration**

NOTE: CO₂ uptake can also be measured by following the uptake of carbon dioxide labelled with ¹⁴C

(b) Rate of **Production of carbohydrates**

This is a **crude** method where a disc is cut out of one side of a leaf (using a cork borer against a rubber bung) and weighed after drying. Some weeks later, a disk is cut out of the other half of the leaf, dried and weighed. Increase in mass of the disc is an indication of the extra mass that has been stored in the leaf.

Explain why this method is inaccurate.

(c) **Measuring the increase in dry mass-**

Dry mass is often monitored by the technique of '*serial harvests*' where several plants are harvested, dried to constant weight and weighed - this is repeated over the duration of the experiment so as to have an accurate measure of the surplus photosynthesis over and above the respiration that has taken place. As with most methods, several plants are needed to have replicate measurements which are used to calculate the average and a standard deviation if necessary.

(d) **Measuring the rate of production of O₂**

Oxygen can be measured by (a) counting bubbles evolved from pond weed with the Audus apparatus **Requirements**

Test tube	plastic tube	Previously well
Watch	connector	illuminated aquatic plant
Water at room temperature	graduated scale	e.g. <i>Elodea</i> or <i>Cabomba</i>
bench lamp to provide light	retort stand	0.2 % sodium bicarbonate solution
Knife	soft board	plastic Syringe
500 cm ³ glass beaker	thermometer	
	capillary tube	
	Ruler	

Procedure:

☞ Set up the apparatus as below in **TOTAL DARKNESS**

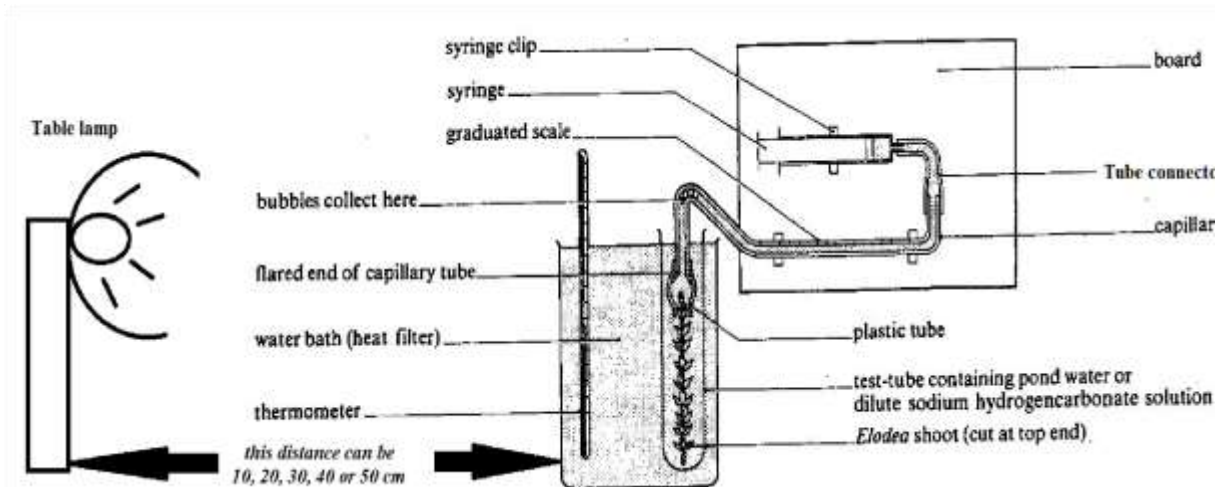

- † A light source is placed 50 cm away facing the test tube and is powered on, a 5 minutes lapse is allowed to enable the plant adjust to the light intensity.
- † The length of gas bubble evolved in 10 second, 30 second, and 1minute intervals is measured by pulling the syringe plunger to draw the bubble slowly along the capillary tube.
- † Steps **above** are repeated with the light source placed at 40 cm from the test tube with the plant, then 30 cm, 20 cm, and finally 10 cm.
- † a control experiment is set up using natural room lighting and repeating the above steps.

Observation / results	Explanation
A colorless gas which relights a glowing splint evolves from the cut end of the plant.	The gas is oxygen released from Photosynthetic reactions.
<ul style="list-style-type: none"> † The rate of gas evolution is directly proportional to light intensity up to a certain illumination i.e. the closer the light source is to the plant; the more oxygen bubbles evolve up to a certain light intensity then remains relatively constant and may decrease. <p><u>Determination of amount of gas released</u> a) if scale is marked in mm³ or cm³: read volume directly b) if scale is marked in mm: calculate volume from $\pi r^2 h$ $\pi=3.14$, r=capillary tube radius, h=distance bubble covers</p>	<ul style="list-style-type: none"> † This is because of the increased light intensity which provides more energy for photo-activation of electron flow. † Increased illumination may not cause any further evolution of oxygen because † of light saturation † other factors limit the process † Increased illumination may cause a decrease in bubble evolution because chlorophyll gets bleached with increased illumination.

Precautions to avoid experimental inaccuracies / errors	Explanation / Remedy
† Temperature fluctuation of the water in the beaker	† Thermostatically controlled bath should be used to maintain temperature constant since it affects photosynthetic activity.
† The experiment must be conducted in total darkness	† To avoid effects of external light fluctuations on photosynthesis
† There must be periodical refilling of HCO ₃ ⁻ solution	† To avoid depletion of carbon dioxide
† The water should be aerated first.	† To saturate the water with oxygen such that the oxygen evolved does not dissolve into water.

✦ Each time the light position is adjusted, a 5-minute lapse must be allowed before bubble counting	✦ To allow the plant equilibrate (adjust) to the new light intensity.
✦ Light intensity fluctuation	✦ Use voltage that gives constant light for a long time
✦ Trapped gas bubbles	✦ Swirl the water weed to release them

NOTE:

- ✦ Instead of measuring the length of bubble, bubbles can be counted, but this has several disadvantages
 - (i) Some bubbles may not be seen due to variations in size, which can be avoided by adding a little detergent to lower the surface tension
 - (ii) Bubbles may evolve very fast to be counted, especially in much illumination.
- ✦ The percentage of oxygen in the evolved gas is **only about 40%** because of dilution by
 - (i) dissolved N₂ or other gases released from solution
 - (ii) CO₂ which had accumulated from respiration, and is first displaced into the capillary tubing, especially if the plant had been kept in the dark

FACTORS INFLUENCING THE RATE OF PHOTOSYNTHESIS

The rate of photosynthesis is affected by a number of factors which are both internal and external (environmental)

Environmental factors

- | | |
|--------------------------------|--|
| ✦ Carbon dioxide concentration | ✦ Some air pollutants e.g. Sulphur dioxide |
| ✦ Light intensity | ✦ Altitude |
| ✦ Temperature | ✦ Salinity |
| ✦ oxygen concentration | |

Internal factors include

- ✦ Chlorophyll concentration
- ✦ Water and dissolved nutrients
- ✦ Enzyme inhibitors e.g. cyanide, dichlorophenol dimethyl urea – DCMU

The level of each factor determines the yield of material by a plant; therefore, it is necessary to first consider the interaction of factors controlling photosynthesis

THE PRINCIPLE OF LIMITING FACTORS

It states that:

‘At any given moment, the rate of a chemical process is limited by the one factor which is nearest its minimum value, and by that factor alone’

A limiting factor is a factor which is nearest to its minimum value in a chemical process that is affected by more than one factor.

Graph illustrating the concept of limiting factors on the rate of photosynthesis

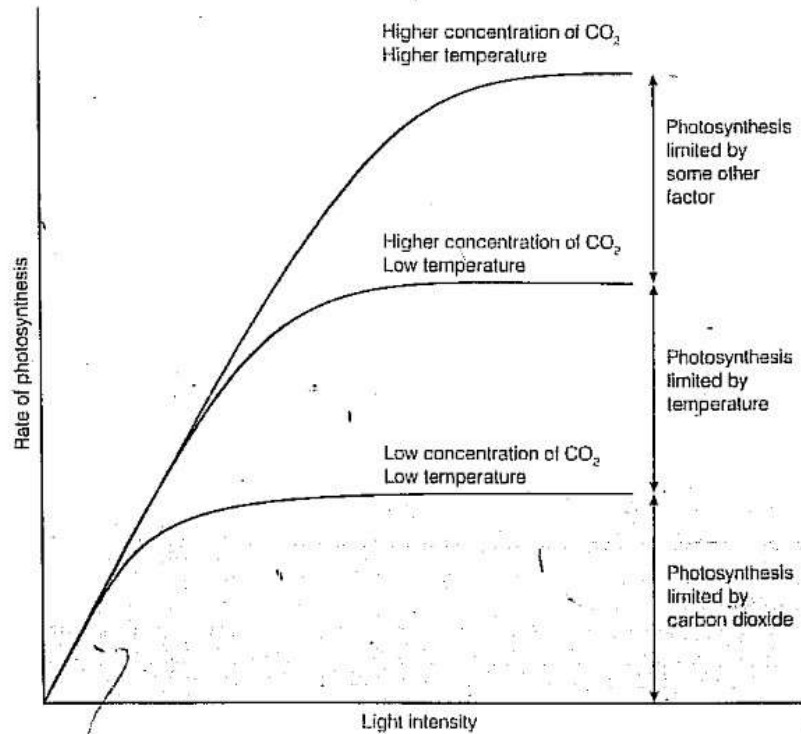

From the graph above, the rate of photosynthesis increases with increase in light intensity and then rate remains constant as the process reaches its maximum rate due to;

(i) The photosynthesis process is going at the fastest possible pace, and no amount of additional light will make it go any faster.

(ii) There is insufficient carbon dioxide available to allow the process to speed up any further

(iii) The temperature is too low for the chemical reactions to go any faster. Therefore, the

rate of photosynthesis can be increased further by increasing either temperature of carbon dioxide concentration which are limiting factors.

(i) **Temperature**

Changes in temperature have little effect on the reactions of the light-dependent stage because these are driven by light, not heat. However, the reactions of the Calvin cycle are catalysed by enzymes which, like all enzymes are sensitive to temperature.

Note:

- † the effect of temperature on these reactions is similar to its effect on other enzymes
- † The optimum temperature varies for each species, but many temperate plants have an optimum temperature ranging from 25°C to 35°C.

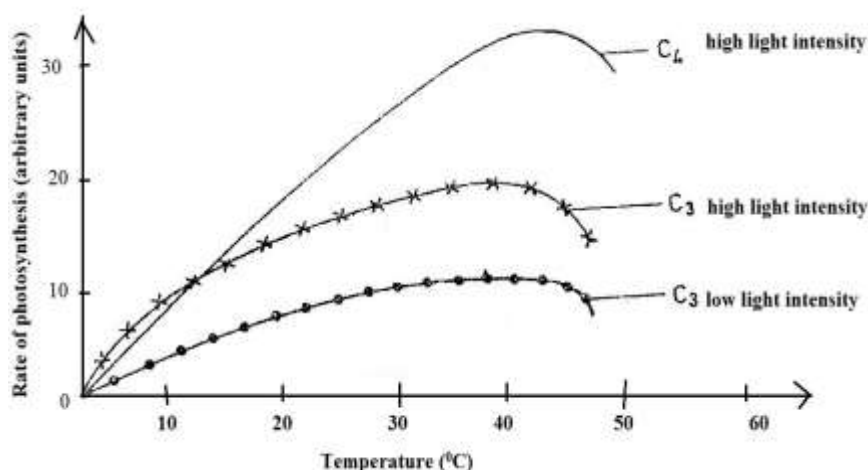

Observation / description	Explanation
✧ Below 10 ⁰ C, C ₃ rate of photosynthesis is higher than in C ₄ above 10 ⁰ C.	✧ C ₄ photosynthetic enzymes are less active in the cold but become more active with increase in temperature.
✧ The maximum rate of photosynthesis attained in C ₄ is much higher than in C ₃	✧ The optimum temperature for enzymes involved in the C ₄ cycle is higher than in the C ₃ cycle
✧ At about 45 ⁰ C, the rate of photosynthesis decreases	✧ Enzymes controlling photosynthesis are denatured by very high temperatures
✧ There is an initial increase in photosynthetic rate to a maximum at about 40-42 ⁰ C, in spite of further increase in temperature	✧ Light intensity becomes a limiting factor in each of the three cases
✧ There is increase in the rate of photosynthesis with increase in temperature until up to at about 40 ⁰ C	✧ Increase in temperature activates enzymes to a level beyond which enzyme denaturation occurs.

(ii) Carbon dioxide concentration

In the atmosphere, the concentration of carbon dioxide ranges from 0.03 to 0.04 %. However, it is found that 0.1% of carbon dioxide in the atmosphere increases the rate of photosynthesis significantly. As long as there is no other facto limiting photosynthesis, an increase in carbon dioxide concentration up to 0.5% usually results in an increase in the rate of photosynthesis.

However, concentrations above 0.1% can damage leaves see the graph below.

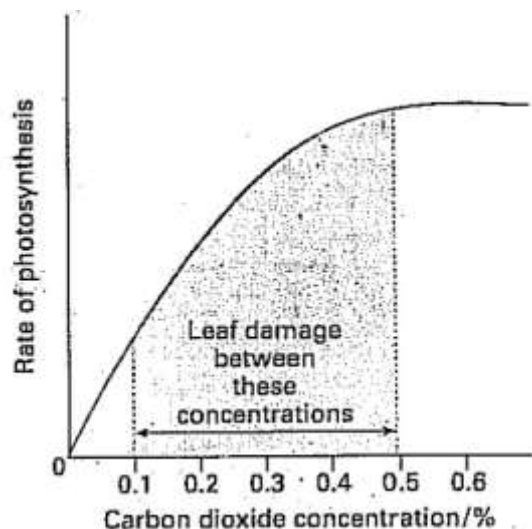

On a warm sunny day, the concentration of carbon dioxide in the air is probably the factor that limits photosynthesis more than any other.

Enriching air with carbon dioxide has a significant effect on crop plants, this is achieved in the greenhouses which are enclosed chambers where plants are grown under controlled conditions. Where the concentration of carbon dioxide is increased by installing gas burners which liberate carbon dioxide as the gas burns.

Qn. Mention other ways the carbon dioxide concentration of the environment can be increased

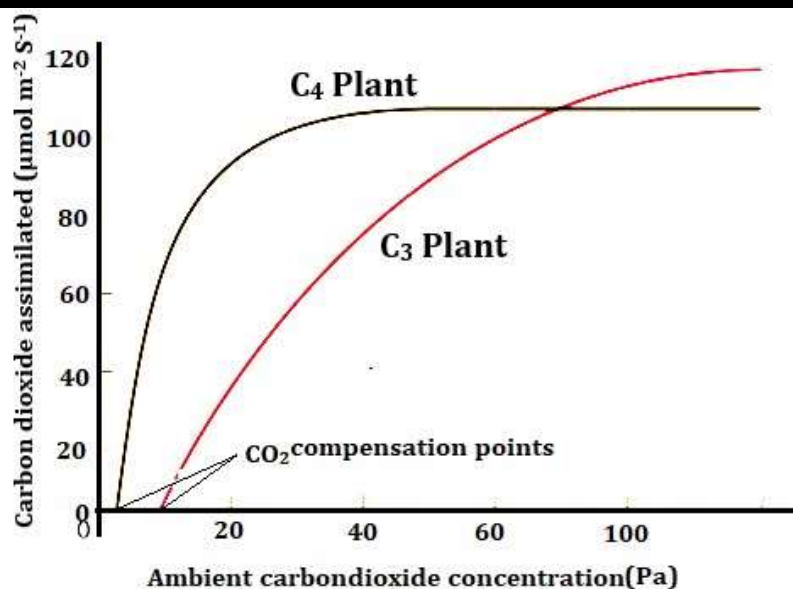

Observation / description	Explanation
✦ the rate of photosynthesis increases rapidly with increasing carbon dioxide concentration to a maximum at 30 Pa in C ₄ plants and 90 Pa in C ₃ plants.	✦ Rubisco fixes carbon dioxide instead of oxygen, because the carbon dioxide concentration is very high out competing oxygen for occupation of active site on RUBISCO.
✦ The rate of photosynthesis increases faster in C ₄ than C ₃ .	✦ PEPCO of C ₄ has a higher affinity for carbon dioxide than Rubisco of C ₃ .
✦ The overall photosynthetic products are greater in C ₃ than in C ₄	✦ C ₄ needs more ATP than C ₃ which generally reduces photosynthetic out put

✦ The C ₄ plants are more efficient at lower CO ₂ concentration while C ₃ more efficient at higher CO ₂	✦ At lower CO ₂ concentration in C ₃ photorespiration reduces the photosynthesis efficiency yet C ₄ plants are not affected by photorespiration as PEPCO has no affinity for oxygen even at very low carbon dioxide concentration.
✦ C ₃ plant has a higher compensation point than C ₄	✦ PEPC has a high affinity for carbon dioxide
✦ After attaining the maximum, the rate of photosynthesis remains constant in both	✦ It is because other factors limit the process e.g. temperature, light intensity etc.

(iii) *Light intensity*

Increase in light intensity results in an increased in the rate of photosynthesis.

With a continuing increase in light intensity a point is reached where carbon dioxide is neither evolved nor absorbed this point is the **Light compensation point**.

Light compensation point is the light intensity at which the photosynthetic intake of carbon dioxide is equal to the respiratory output of carbon dioxide.

The time taken for a plant which has been in darkness to reach the compensation point is called the **compensation period**. It occurs during early morning or late evenings. This varies for different plants.

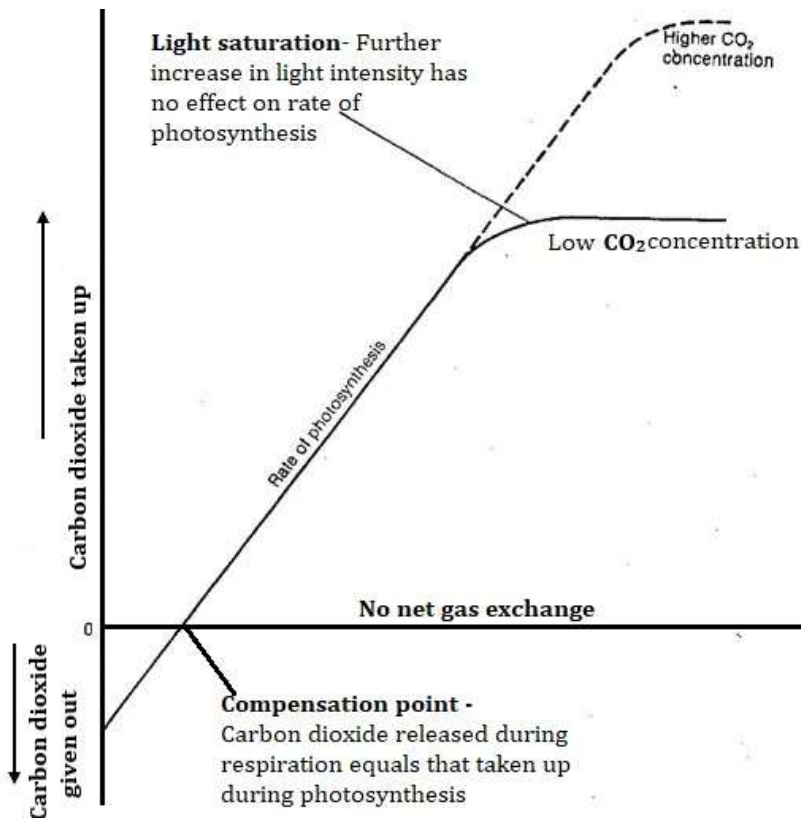

However, after reaching a certain light intensity further increase in light intensity has no effect on the rate because photosynthetic pigments have become saturated with light, and some other factor either availability of carbon dioxide, amount of chlorophyll or temperature stops the reaction from going faster. Very high intensities may actually damage some plants in fact, it bleaches the chlorophyll reducing their ability to photosynthesize.

SUN AND SHADE PLANTS

Sun plant are those with leaves growing on branches exposed to direct sunlight while shade plants are those with leaves growing on branches exposed to light that has passed through leaves.

- ✦ In **low light**, plants need to maximise light absorption for photosynthesis to exceed respiration if they are to survive.
- ✦ In **high light** environment, plants maximise their capacity for utilising abundant light energy, while at the same time dealing with excess sunlight which can bleach chlorophyll.

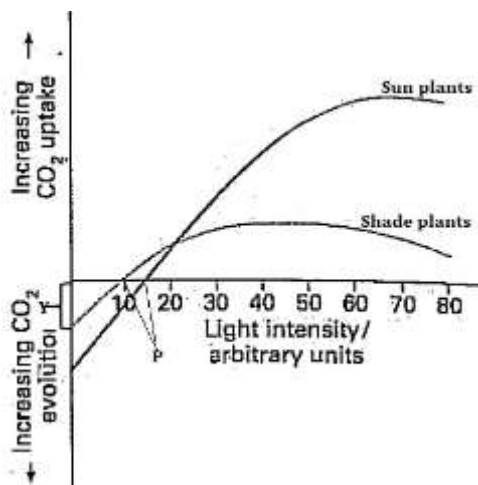

- At very low light intensity, shade plants have higher CO₂ uptake; these photosynthesize best at low light intensities which reduces with illumination.
- sun plants have a higher light compensation point than shade plants;
- shade plants have relatively low light compensation point this is a physiological adaptation which enables shade plants to make efficient use of light of low intensity.
- P represents compensation point at which CO₂ uptake equals CO₂ output.

- At Y biomass decreases because the rate of respiration exceeds that of photosynthesis.
- **ADAPTATIONS TO PHOTOSYNTHESIS IN SUN AND SHADE**

Adaptation: a genetically determined capability to acclimate to environmental condition.

Shade plant	Sun plants
<ul style="list-style-type: none"> ✦ Abundant chlorophyll <i>b</i> (low chlorophyll <i>a</i> to chlorophyll <i>b</i> ratio) which gives leaves dark green colour to increase light absorption in the dark; ✦ Palisade/ spongy mesophyll ratio low to allow maximum light penetration; ✦ Mesophyll cell surface / leaf area ratio low to maximise light trapping; ✦ Leaf orientation horizontal to maximise light trapping; ✦ Reddish leaf undersides to enhance reflectance back up through the photosynthetic tissue; giving the plant a second chance to utilize the light. ✦ Stomatal density low to avoid over cooling; ✦ Thin leaves to maximise light penetration; ✦ Stomatal size large to allow loss of excess water; ✦ Elongated internodes for increased access to light; ✦ Chloroplast size large to increase the surface area for storage of photosynthetic pigments. 	<ul style="list-style-type: none"> ✦ Abundant chlorophyll <i>a</i> (high chlorophyll <i>a</i> to chlorophyll <i>b</i> ratio) to increase light absorption; ✦ Palisade/ spongy mesophyll ratio high to minimise light penetration; ✦ Mesophyll cell surface / leaf area ratio high to minimize excessive light and transpiration; ✦ Leaf orientation erect to minimise light trapping; ✦ Stomatal density high to avoid over heating; ✦ Much carotenoids to prevent damage to chlorophyll from very bright light. ✦ Thick leaves to minimise light penetration; ✦ Stomatal size small to minimise water loss; <p>Other features</p> <ul style="list-style-type: none"> (i) RuBISCO and soluble protein content /mass higher (ii) Chlorophyll / soluble protein ratio high (iii) Chloroplast size small

Exercise 4

1. The table 1 below shows the rate at which carbon dioxide is taken up (+) and released (-) from stem of an herbaceous plant and from a single leaf of the same species at different light intensities.

Light intensity (arbitrary units)	UPTAKE (+) AND RELEASE (-) OF CARBONDIOXIDE /mg50cm ⁻² h ⁻¹	
	STEM	LEAF
0.0	-0.5	-0.5
1.0	-0.2	+0.6
2.5	+0.3	+2.8
4.0	+0.7	+4.6
5.0	+1.0	+5.3
7.0	+1.6	+6.0
11.0	+2.5	+6.3

- (a) Present the data provided in the table above in a suitable graph. (06 marks)
- (b) Calculate the rate at which carbon dioxide is used in photosynthesis by 50cm² of the plant organ at light intensity of 3 arbitrary units. (03 marks) (c)

Explain,

- (i) the rate of uptake and release of carbon dioxide of the leaf of a plant as light intensity increases. (14 marks)
- (ii) the difference in the rate of uptake of carbon dioxide of leaf and stem of plants. (06 marks)
- (iii) From your graph, the difference in the light compensation points of the leaf and stem of plants. (04 marks)
- (d) Suggest any three practical difficulties you would meet in conducting an experiment to obtain data of the kind given in the table. (03 marks)
- (e) State physiological problems likely to be faced by a plant beyond light intensity of 3 arbitrary units. (04 marks)

(iv) Salinity

Increase in salinity brings about osmotic stress, leading to drought stress or ‘water stress’. This results in stomata closure in an effort to avoid desiccation, which reduces photosynthesis because uptake of CO₂ reduces.

(v) Chlorophyll Concentration

The concentration of chlorophyll affects the rate of reaction as they absorb the light energy without which the reactions cannot proceed. Lack of chlorophyll or deficiency of chlorophyll results in **chlorosis** or **yellowing** of leaves. It can occur due to disease, mineral deficiency or the natural process of aging (senescence). Lack of iron, magnesium, nitrogen and light affect the formation of chlorophyll and thereby causes chlorosis. **(vi) Water**

The effect of water can be understood by studying the yield of crops which is the direct result of photosynthetic activity. It is found that even slight deficiency of water results in significant reduction in the crop yield. The lack of water not only limits the amount of water but also the quantity of carbon dioxide. This is because in response to drying the leaves close their stomata in order to conserve water being lost as water vapour through them. **(vii) Pollution**

Pollution of the atmosphere with industrial gases has been found to result in as much as 15% loss. Soot can block stomata and reduce the transparency of the leaves. Some of the other pollutants are ozone and sulphur dioxide. In fact, lichens are very sensitive to sulphur dioxide in the atmosphere. Pollution of water affects the hydrophytes. The capacity of water to dissolve gases like carbon dioxide and oxygen is greatly affected.

(viii) altitude and oxygen

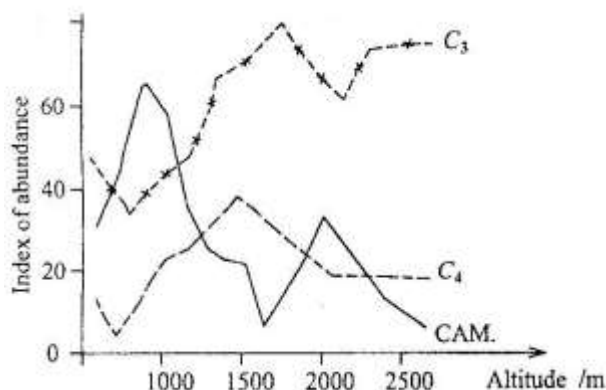

Relative grass species composition and coverage along an elevational gradient in Hawaii Volcanoes National Park. Data adapted from Newell (1968)

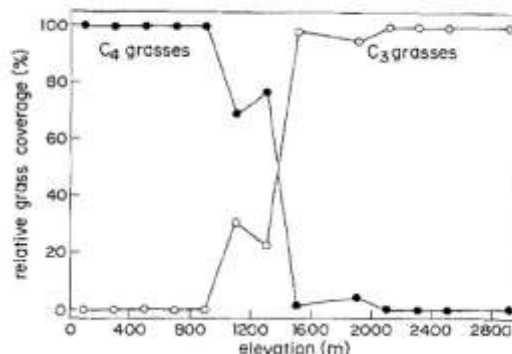

Observation / description	Explanation
✦ C ₃ plants are more abundant at high altitude/elevation	✦ The decrease in atmospheric pressure at higher altitude decreases the partial pressure of oxygen enables more productivity since photorespiration reduces
✦ CAM plants are more abundant at low altitude	✦ Even when temperature is high, nocturnal stomatal opening and closure in day light enables them to reduce transpiration. ✦ CAM plants that store a lot of malate and due to its high osmotic value conserve a lot of water, are usually less frost resistant than C ₃ plants.

† C4 plants are widely distributed at low altitude and slight elevation	† The enzymes are tolerant to these high temperatures and the Kranz mesophyll anatomy shields Rubisco in bundle sheath cells from much oxygen to avoid photorespiration.
---	--

Exercise 5

1. a) Explain the significance of pigments and light in photosynthesis. (12 marks)
 (b) How does altitude affect distribution of C₃ and C₄ plants? (08marks)

PRODUCTIVITY OF PLANTS AND PLANT COMMUNITIES

The entire plant is potential food for consumer organisms. Plants normally grow with others of the same species or of different species in plant communities e.g. a field of wheat, natural forest and a woodland. The efficiency with which whole plants and plant communities produce dry matter determines how much food is available for the higher trophic levels in an ecosystem.

Factors of fundamental importance to crop yield

- † Leaf area index
- † Unit leaf rate

1. Leaf area index

Plants with a large surface area of leaves and other parts which can photosynthesise may be expected to produce more dry matter than plants having shoot systems with small surface area. The area of leaves available for photosynthesis can be expressed as the leaf area index (LAI)

$$LAI = \frac{\text{Total leaf area of plant}}{\text{area of ground covered by plant}}$$

It determines the amount of light intercepted by the shoot system of a plant.

During the early stages of growth, crop plants have small LAI values because each plant has only a few small leaves and is surrounded by a patch of bare ground, as growth proceeds and the shoot system enlarges, the LAI increases

Note

The shape of the shoot system is particularly important in determining the leaf area index of a plant where plants which can be grown close to each other and which have leaves held vertically have higher LAI than those with horizontally held or drooping leaves.

2. Unit leaf rate

Whatever the LAI value, increases in organic matter occur efficiently only if most of the photosynthetic products are converted to plant tissue or storage materials. If most of the products of photosynthesis are respired dry matter accumulates slowly.

[DOWNLOAD MORE RESOURCES LIKE THIS ON ECOLEBOOKS.COM](http://Ecolebooks.com)

Unit leaf rate expresses the efficiency of dry matter accumulation by green plants. ULR of a plant can be calculated from measurements of the leaf area and dry mass of a representative sample of plants at different stages of growth.

Note

✦ Some species have higher ULR values than others because they do not photorespire and have very short compensation periods. E.g. C4 plants such as sugar cane and maize have a much greater unit leaf rate than most C3 plants.

Synthesis of dry matter by green plants is called primary production, the total amount of dry matter produced per unit area of ground per year is called gross primary productivity. Some dry matter is used by green plants in respiration. What is left is called net primary productivity (NPP) and it is which is available for consumer organisms including man **$NPP = LAI \times ULR$**

Therefore, plants which quickly achieve high LAI values and which sustain an efficient ULR over a long growing period are highly productive.

Exercise 6

1. The figure below shows the changes in leaf area index (ratio of leaf surface to soil surface (m^2cm^{-2}) of two species of clover, *Triforium ripens* and *Triforium fragiferum*, growing in a pure and mixed stand.

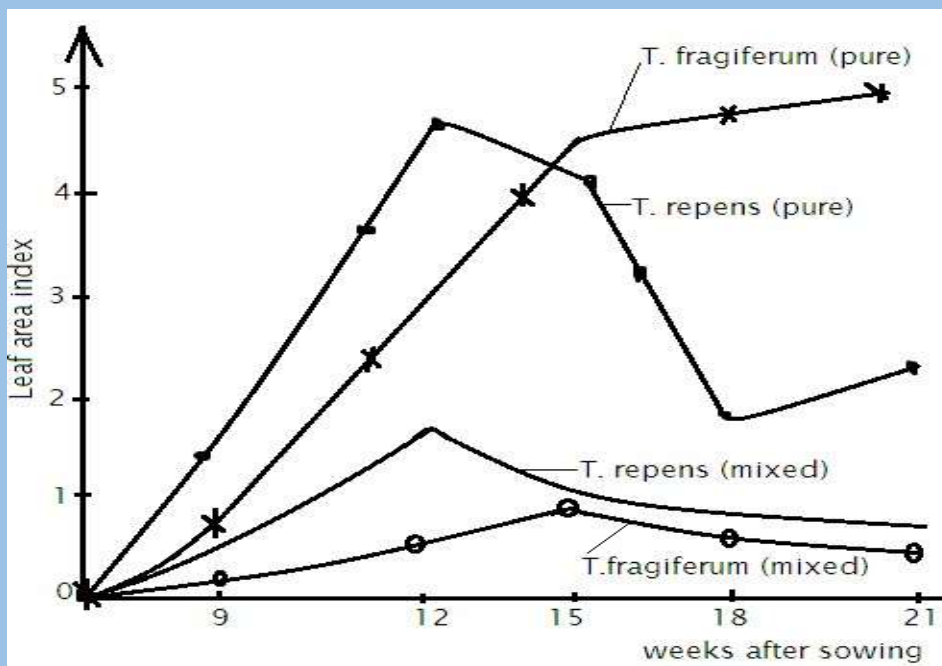

Table 1: shows the characteristics of the petioles and leaf size of the two species of clover.

Characteristics

	T. fragiferum	T.repens
Petiole length	Long	Short
Leaf size	Large	Small

Use the information in the figure and table to answer the questions that follow,

a) Compare the leaf area index of *Trifolium repens* and *T.fragiferum* in the,
(i) pure stands.(06 marks) (ii) mixed stands. (06 marks)

b) Explain the trend in leaf area index for *Trifolium repens* in pure stands.
(10 marks)

c) Explain the differences in growth rate of the two species in mixed stands.
(07 marks)

d) Explain why *Trifolium fragiferum* continues to grow after the peak of *Trifolium repens*?
(04 marks)

(fe) What conclusion can you draw from the results in a mixed stand? (04 marks)

) What other factors are likely to have caused the difference in growth rate of the two species in mixed stand? (03 marks)