

PRESSURE

To make sense of the effects of a force acting on a body, we have to also consider the area to which the force acts.

Definition:

Pressure is the force acting normally per unit area of the surface.

$$\text{Pressure} = \frac{\text{Force (N)}}{\text{Area (m}^2\text{)}}$$

The SI unit of pressure is Newton per metre squared [N/m^2 (Nm^{-2})] or Pascals (**Pa**).
Therefore, 1 *Newton per metre squared* ($1Nm^{-2}$) = 1 *Pascal* (**1Pa**).

Definition:

A **Pascal** is the pressure exerted on a body when a force of **1N** acts normally on an area of **1m²**.

Other units of pressure include; **cmHg**, **mmHg**, **atmospheres**, **kPa**
Pressure is a scalar quantity.

Examples:

When calculating for pressure, the area should always be in **m²**.

1. A man of mass 84kg stands on a floor. If the area of contact of his shoes on the floor is $0.042m^2$, find the pressure exerted by the man on the floor.

$m = 84kg, \quad A = 0.042m^2$

$F = mg$	$P = \frac{F}{A}$
$F = 84 \times 10$	
$F = 840N$	
	$P = \frac{840}{0.042}$
	$P = 20000Nm^{-2}$ or Pa

2. A car piston exerts a force of 200N on a cross-sectional area of $40cm^2$. Find the pressure exerted by the piston.

$F = 200N, \quad A = 40cm^2 = \frac{40}{10000} = 0.004m^2$

$$P = \frac{F}{A}$$

$$P = \frac{200}{0.004}$$

$P = 50000Nm^{-2}$ or Pa

3. A block of mass 40kg exerts a pressure of $20Nm^{-2}$ on the surface. Find the area of contact between the block and the surface.

$m = 40kg, \quad P = 20Nm^{-2}$

$F = mg$	$P = \frac{F}{A}$
$F = 40 \times 10$	
$F = 400N$	
	$20 = \frac{400}{A}$
	$A = \frac{400}{20}$
	$A = 20m^2$

4. A force of 100N is applied to an area of 100mm^2 . What is the pressure exerted?

$$F = 100\text{N}, \quad A = 100\text{mm}^2 = \frac{100}{1000000} = 0.0001\text{m}^2$$

$$P = \frac{F}{A}$$

$$P = \frac{100}{0.0001}$$

$$P = 1000000 \text{ Nm}^{-2} \text{ or Pa}$$

5. A glass block of mass 60g exerts a pressure of 1000Nm^{-2} on a table top. Determine the area of contact between the glass block and the table top.

$$m = 60\text{g} = \frac{60}{1000} = 0.06\text{kg}, \quad P = 1000\text{Nm}^{-2}$$

$F = mg$ $F = 0.06 \times 10$ $F = 0.6\text{N}$	$P = \frac{F}{A}$ $1000 = \frac{0.6}{A}$ $A = \frac{0.6}{1000}$ $A = 0.0006\text{m}^2$
---	--

MAXIMUM AND MINIMUM PRESSURE

From the formula, $P = \frac{F}{A}$ it is noted that pressure increases with a decrease in area and vice versa.

Maximum pressure:

To obtain maximum pressure, the area should be small.

$$\text{Maximum pressure} = \frac{\text{Force}}{\text{Smallest area}}$$

Minimum pressure:

To obtain minimum pressure, the area should be large.

$$\text{Minimum pressure} = \frac{\text{Force}}{\text{Largest area}}$$

Examples:

Where necessary acceleration due to gravity = 10ms^{-2}

1. The figure below shows a block of wood of weight 25N placed on a flat horizontal surface.

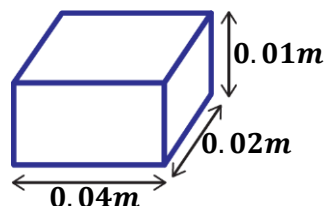

- a) Find the minimum pressure it can exert on the surface.
- b) Find the maximum pressure it can exert on the surface

$$F = 25N$$

$$\text{Largest area} = L \times W$$

$$\text{Largest area} = 0.04 \times 0.02$$

$$\text{Largest area} = 0.0008m^2$$

$$\text{Min pressure} = \frac{\text{Force}}{\text{Largest area}}$$

$$\text{Min pressure} = \frac{25}{0.0008}$$

$$\text{Min pressure} = 31,250 Pa$$

$$\text{Smallest area} = W \times H$$

$$\text{Smallest area} = 0.02 \times 0.01$$

$$\text{Smallest area} = 0.0002m^2$$

$$\text{Max pressure} = \frac{\text{Force}}{\text{Smallest area}}$$

$$\text{Max pressure} = \frac{25}{0.0002}$$

$$\text{Max pressure} = 125,000 Pa$$

NOTE:

$$\text{Largest area} = (\text{Largest length}) \times (\text{Next largest length})$$

$$\text{Smallest area} = (\text{Smallest length}) \times (\text{Next smallest length})$$

2. The dimensions of a cuboid of mass 48kg are 5cm × 10cm × 20cm. Calculate the maximum and minimum pressure it exerts.

$$F = mg = (48 \times 10) = 480N$$

$$\text{Smallest area} = \frac{5}{100} \times \frac{10}{100} = 0.005m^2$$

$$\text{Largest area} = \frac{10}{100} \times \frac{20}{100} = 0.02m^2$$

$$\text{Min pressure} = \frac{\text{Force}}{\text{Largest area}}$$

$$\text{Min pressure} = \frac{480}{0.02}$$

$$\text{Min pressure} = 24,000 Pa$$

$$\text{Max pressure} = \frac{\text{Force}}{\text{Smallest area}}$$

$$\text{Max pressure} = \frac{480}{0.005}$$

$$\text{Max pressure} = 96,000 Pa$$

3. A block of wood of mass 1200g measures by 30cm by 6cm by 5cm. Calculate;
- the greatest pressure.
 - the least pressure exerted by the wood on the surface.

$$F = mg = \left(\frac{1200}{1000} \times 10\right) = 12N$$

$$\text{Smallest area} = \frac{6}{100} \times \frac{5}{100} = 0.003m^2$$

$$\text{Largest area} = \frac{30}{100} \times \frac{6}{100} = 0.018m^2$$

a)

$$\text{Greatest pressure} = \frac{\text{Force}}{\text{Smallest area}}$$

$$\text{Greatest pressure} = \frac{12}{0.003}$$

$$\text{Greatest pressure} = 4000 Pa$$









b)

$$\text{Least pressure} = \frac{\text{Force}}{\text{Largest area}}$$

$$\text{Least pressure} = \frac{12}{0.018}$$

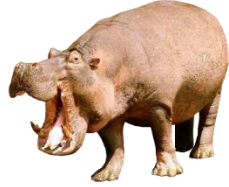
$$\text{Least pressure} = 666.7 Pa$$

Minimum and maximum pressure explains the following;

<ul style="list-style-type: none"> ➤ An elephant is able to walk on a soft ground without sinking because it has toes with a large surface area thus exerting less pressure on the ground. 	
<ul style="list-style-type: none"> ➤ A tractor is made with broad wheels is able to move on a soft ground without sinking because the large surface area of the wheels makes it to exert less pressure on the ground. 	
<ul style="list-style-type: none"> ➤ A nail has a pointed end hence having a small surface area at the end. This makes it to exert much pressure on material thus penetrating the material easily. 	
<ul style="list-style-type: none"> ➤ A goat sinks in mud because of the small surface area of its feet hence exerting much pressure on the mud. 	
<ul style="list-style-type: none"> ➤ A hippopotamus is able to move on a soft ground without sinking because it exerts less pressure on the ground due to its wide feet. 	
<ul style="list-style-type: none"> ➤ Bridges are made thicker at the base than at the top to avoid collapse of the bridge by exerting less pressure on water and ground. 	
<ul style="list-style-type: none"> ➤ It is not easy to move on a soft ground with high-heeled pointed shoes because they exert much pressure on the soft ground. 	
<ul style="list-style-type: none"> ➤ It is easier to peel matooke using a sharp knife than using a blunt knife because a sharp end of a knife has a small surface area thus exerting much pressure on the matooke. This makes it penetrate the matooke easily. 	

EXERCISE:

1.
 - a) Define pressure and state its SI unit.
 - b) A block measuring $0.1m \times 0.2m \times 0.8m$ has a mass of 20kg. What is the maximum and minimum pressure it can exert on the ground?
 - c) Explain why a sharp knife cuts easily than a blunt knife.

2.
 - a) Explain why a hippopotamus can easily walk on mud without sinking than a goat.
 - b) A rectangular block of wood weighs 3N and measures $2cm \times 3cm \times 4cm$. What is the greatest pressure it can exert on a horizontal surface.

3.
 - a) Explain what happens when a balloon is placed on
 - i) a sharp needle.
 - ii) thumb of a hand.
 - b) Calculate the maximum pressure of a glass block of density $2.5gcm^{-3}$ would exert on a horizontal surface if the block is measured $20 \times 10 \times 5cm$.

4.
 - a) A block of concrete weighs 900N and its base is a square of side 3m. What pressure does the block exert on the ground?
 - b) Explain the following observations:
 - i) A person feels much pain when pierced by a sharp nail than a blunt nail.
 - ii) It is harder to walk on a soft ground with narrow-heeled shoes than wide-heeled shoes.

5.
 - a) A box of dimensions $6m \times 2m \times 4m$ exerts its weight of 400N on the floor. Determine its;
 - i) maximum pressure.
 - ii) minimum pressure.
 - iii) density.
 - b) Explain the following observations in real life.
 - i) A hippopotamus is able to walk on the mud but a goat gets stuck.
 - ii) A woman putting on high-heeled shoes damages a cemented floor compared to one putting on flat shoes.
 - iii) Water containers (reservoirs) are usually made wide at the base.
 - iv) A very tall building is made wider and thicker at the bottom than at the top.
 - v) The rear tyres of a tractor are made wider than the front ones.

6. The tank below has a mass of 2.5kg.

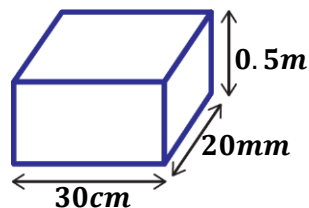

Determine the minimum and maximum pressure exerted by the tank on the ground when it is;

- i) empty.
- ii) filled with water up to the brim.
- iii) half-filled with water

$$\text{Density of water} = 1000kgm^{-3}$$

PRESSURE IN LIQUIDS

Since liquids take up the shape of the container in which they are placed, the volume of liquid filling a container is equal to the volume of the container.

Consider a cylindrical container of cross-sectional area (base area), A filled with a liquid of density, ρ to a height, h as shown below.

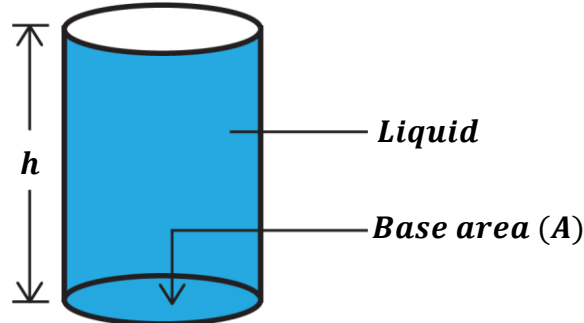

$$\begin{aligned} \text{Volume of liquid} &= \text{Volume of cylindrical container} \\ &= \text{Area of circular base} \times \text{Height} \\ &= Ah \end{aligned}$$

$$\begin{aligned} \text{Mass of liquid} &= \text{Density liquid} \times \text{Volume of liquid} \\ &= \rho Ah \end{aligned}$$

$$\begin{aligned} \text{Force exerted by liquid (Weight of liquid)} &= \text{mass} \times \text{acceleration due to gravity} \\ &= \rho Ah \times g \\ &= Ah\rho g \end{aligned}$$

$$\begin{aligned} \text{Pressure} &= \frac{\text{Force}}{\text{Area}} \\ P &= \frac{Ah\rho g}{A} \end{aligned}$$

$$\boxed{P = h\rho g}$$

OR

Consider a cylindrical container with a circular base of radius, r filled with a liquid of density, ρ to a height, h as shown below.

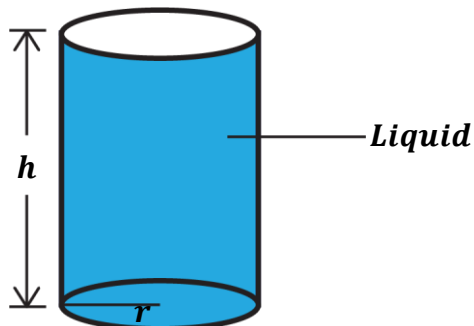

$$\begin{aligned} \text{Volume of liquid} &= \text{Volume of cylindrical container} \\ &= \pi r^2 h \end{aligned}$$

$$\begin{aligned} \text{Mass of liquid} &= \text{Density of liquid} \times \text{Volume of liquid} \\ &= \rho \pi r^2 h \end{aligned}$$

$$\begin{aligned} \text{Weight of liquid} &= \text{mass} \times \text{acceleration due to gravity} \\ &= \rho \pi r^2 h \times g \\ &= \pi r^2 h \rho g \end{aligned}$$

$$\begin{aligned} \text{Pressure} &= \frac{\text{Force}}{\text{Area}} \\ P &= \frac{\pi r^2 h \rho g}{\pi r^2} \end{aligned}$$

$$\boxed{P = h\rho g}$$

Factors affecting pressure in liquids:

From the above derivations, pressure at any point in a liquid is the same in all directions and it depends on the following factors:

a) Depth (height) below the liquid surface (h):

Pressure increases with an increase in the depth of the liquid and vice versa.

The higher the depth of the liquid, the more the weight of the liquid thus increasing the pressure exerted by the liquid.

b) Density of the liquid (ρ):

Denser liquids exert more pressure than less dense liquids.

c) Acceleration due to gravity (g):

Liquid pressure is higher in areas (planets) whose acceleration due to gravity is high.

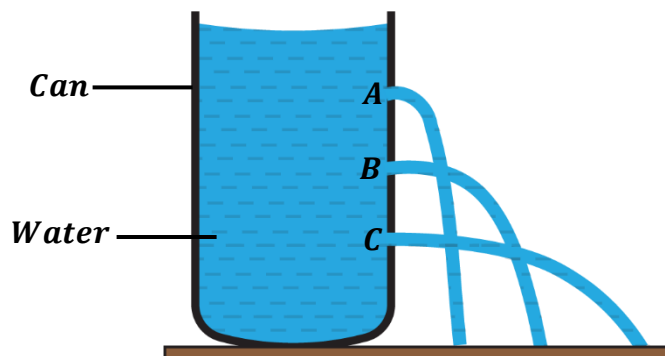
Experiment to show that pressure in a liquid depends on the depth below the liquid surface.**Procedures:**

- Three equally spaced holes **A**, **B** and **C** of the same size are made on one vertical side of a tall can at different depth.
- The holes are then closed and the can is filled with water.
- The holes are then opened at the same time and the jetting of water from the holes observed.

Observation:

- It is observed that water comes out fastest and lands furthest from the lowest hole **C** followed by **B** and lastly hole **A**.
- Therefore, pressure at **A** is greater than pressure at **B** and **C**.
- This shows that pressure increases with increase in the depth below the surface of a liquid.

WATER SUPPLY SYSTEM:

Water supply often comes from a reservoir which is at a high ground level. Water flows from the reservoir through the pipes to the taps which are below the level of the water reservoir. This increases the pressure at which water is supplied.

This explains why storage tanks are put at high level ground than the taps so that water comes through the taps at a very high pressure.

NOTE:

- ❖ Pressure of the liquid does not depend on the cross-sectional area of the container in which it is placed.
- ❖ Pressure of a liquid does not depend (independent) on the shape and size of the container.

Experiment to show that pressure is independent of the cross-sectional area and the shape of the container

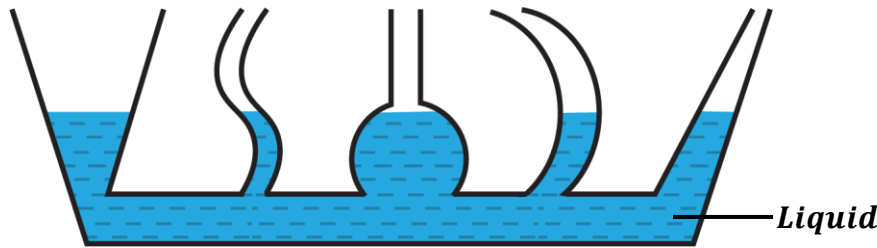

- A liquid is poured into a set of connected tubes with different shapes called **communicating tubes**.
- The liquid flows until the levels of the liquid are the same in all the tubes. This shows that the liquid finds its own level and the pressure is the same in all tubes.
- Therefore, pressure in liquids is independent of the shape and the cross-sectional area of the container.

Examples:

(Acceleration due to gravity = 10ms^{-2})

1. Find the pressure in a liquid of density 1000kgm^{-3} at a height of 8m .

$$\begin{aligned}\rho &= 1000\text{kgm}^{-3}, & h &= 8\text{m} \\ P &= h\rho g \\ P &= 8 \times 1000 \times 10 \\ P &= 80,000 \text{ Pa}\end{aligned}$$

2. The pressure of a liquid is 10000Nm^{-2} . What is the height of the liquid if its density is 1000kgm^{-3} ?

$$\begin{aligned}\rho &= 1000\text{kgm}^{-3}, & P &= 10000\text{Nm}^{-2} \\ P &= h\rho g \\ 10000 &= h \times 1000 \times 10 \\ h &= \frac{10000}{10000} \\ h &= 1\text{m}\end{aligned}$$

3. The pressure exerted in a liquid of density 0.4gcm^{-3} is 8000 Pa . Calculate its height.

$$\begin{aligned}\rho &= 0.4\text{gcm}^{-3} = (0.4 \times 1000) = 400\text{kgm}^{-3}, & P &= 8000\text{Pa} \\ P &= h\rho g \\ 8000 &= h \times 400 \times 10 \\ h &= \frac{8000}{4000} \\ h &= 2\text{m}\end{aligned}$$

4. What is the pressure 100m below the surface of sea water of density 1150kgm^{-3} ?

$$\begin{aligned}\rho &= 1150\text{kgm}^{-3}, & h &= 100\text{m} \\ P &= h\rho g \\ P &= 100 \times 1150 \times 10 \\ P &= 1150000 \text{ Pa} \\ P &= 1.15 \times 10^6 \text{ Pa}\end{aligned}$$

5. The tank below contains mercury and water. The density of mercury is 13600kgm^{-3} and that of water is 1000kgm^{-3} .

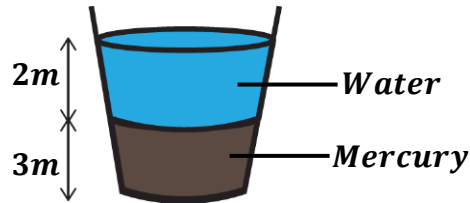

Find the total pressure exerted at the bottom of the tank.

$$\rho_w = 1000\text{kgm}^{-3}, \quad \rho_m = 13600\text{kgm}^{-3}, \quad h_w = (2 + 3) = 5\text{m}, \quad h_m = 3\text{m}$$

Total pressure = pressure of water + pressure of mercury

$$\text{Total pressure} = h_w\rho_w g + h_m\rho_m g$$

$$\text{Total pressure} = (5 \times 1000 \times 10) + (3 \times 13600 \times 10)$$

$$\text{Total pressure} = 50000 + 408000$$

$$\text{Total pressure} = 458,000 \text{ Pa}$$

6. The density of liquid is 800kgm^{-3} . It was poured in a container to a depth of 400cm . Calculate the pressure it exerts at the bottom of the container.

$$\rho = 800\text{kgm}^{-3}, \quad h = 400\text{cm} = \frac{400}{100} = 4\text{m}$$

$$P = h\rho g$$

$$P = 4 \times 800 \times 10$$

$$P = 32,000 \text{ Pa}$$

EXERCISE:

(Acceleration due to gravity = 10ms^{-2} and Density of water = 1000kgm^{-3})

- Calculate the pressure at the bottom of a swimming water pool 1000cm deep.
- A diver dives to a depth of 20m below the surface of sea water of density 1000kgm^{-3} . Calculate the pressure experienced.
- A flask is filled to a depth of 16cm with a liquid of density 800kgm^{-3} . Find the pressure exerted by the liquid on the base.
- The pressure at the bottom of a column of mercury of density 13600kgm^{-3} is 50Nm^{-2} . Calculate the height of the mercury column.
- Show that the pressure of a liquid in a cylindrical can of height, h and radius, r is $h\rho g$ where ρ is the density of the liquid.
 - Calculate the pressure due to water experienced by a diver working 15m below the surface of the sea.
 - Describe an experiment to show that the pressure of a liquid is independent of the cross-sectional area.

TRANSMISSION OF PRESSURE IN FLUIDS

A fluid is a substance which can flow e.g. a liquid or a gas.

PASCAL'S PRINCIPLE (Principle of transmission of pressure in fluids):

Pascal's principle states that pressure applied at any point of an enclosed fluid is transmitted equally throughout the whole fluid in all directions.

NOTE: Pascal's principle works on an assumption that the fluid is incompressible.

Definition:

An incompressible fluid is a fluid whose volume can not be reduced by squeezing i.e. it can not be compressed e.g water but not air.

Experiment to demonstrate Pascal's principle:

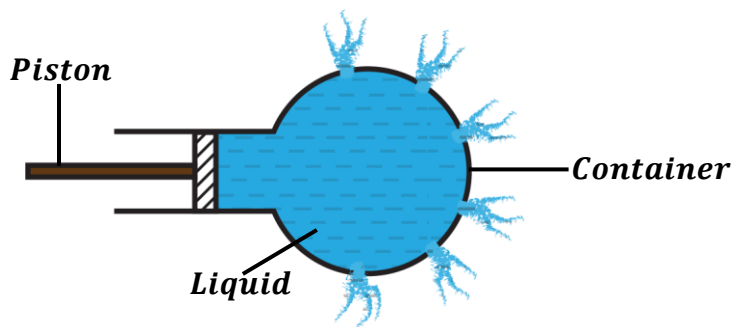

Procedures:

- Holes of equal size are made at different points in a container.
- The container is filled with the liquid as shown above.
- The piston is pushed inside the container to exert pressure on the liquid.

Observation:

- The liquid comes out of the holes with an equal force and pressure. This shows that pressure was equally transmitted throughout the whole liquid.

Practical example:

A glass bottle is filled with water and covered with a cork.

- a) Explain why the bottom of the bottle breaks when a greater force is applied on the cork to push it down.

When a force is applied on the cork, pressure is exerted inside the water and it is transmitted equally throughout the whole bottle. Therefore, equal pressure is exerted on the bottom by the bottle thus breaking it.

- b) Explain why a liquid like water was used instead of a gas in (a) above.

Since the experiment required transmission of pressure, it needed a fluid which is incompressible. Therefore, a liquid like water is incompressible yet a gas is not.

RECALL: *Pascal's principle applies only to incompressible fluids.*

APPLICATIONS PASCAL'S PRINCIPLE

The principle of transmission of pressure in fluids is applied in hydraulic machines namely;

- Hydraulic press.
- Hydraulic lift.
- Hydraulic jack.
- Hydraulic brake.

In hydraulic machines, a small force applied at one point of an incompressible liquid produces a larger force at the points of the liquid. Therefore, a small force is used to lift heavy materials like cars.

HYDRAULIC PRESS / LIFT / JACK:

- It consists of a small piston fitted in a small cylinder and a large piston fitted in the large cylinder.
- When a force is applied on a small piston, the pressure exerted by the piston is transmitted equally throughout the liquid to the larger piston thus forcing the larger piston to move up.
- This force exerted on the larger piston raises a heavy load as shown below.

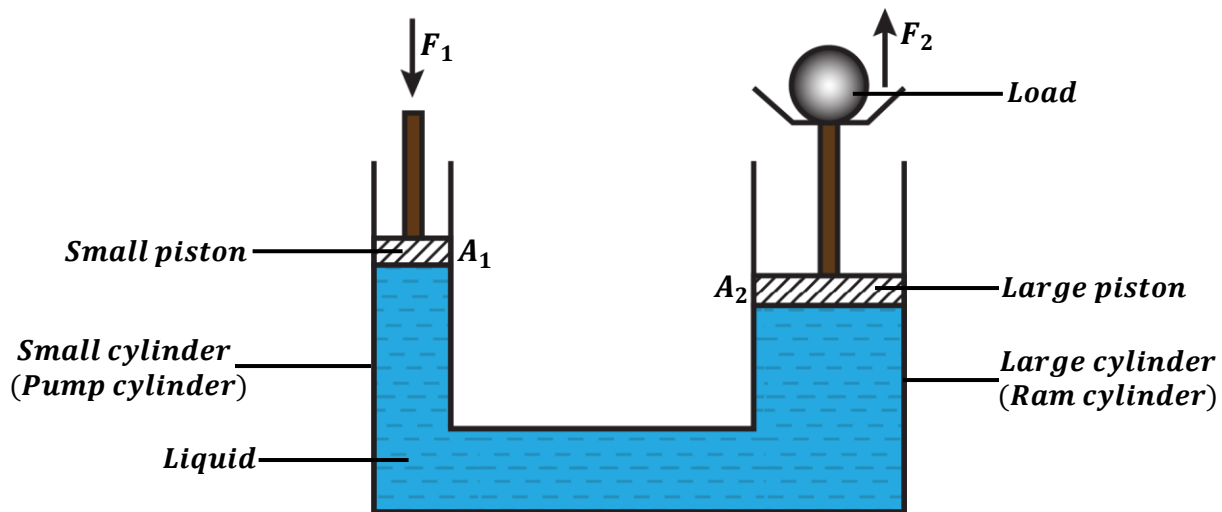

Operation of hydraulic machines

- ❖ When a small force, F_1 is applied on the small piston of cross-sectional area, A_1 , then pressure, P_1 is exerted on the liquid by a small piston.

$$P_1 = \frac{F_1}{A_1}$$

- ❖ The pressure, P_1 is transmitted equally throughout the liquid to the larger piston. Hence, the pressure, P_2 acting on the larger piston is equal to initial pressure, P_1 .

$$P_2 = \frac{F_2}{A_2}$$

$$P_1 = P_2$$

$$\frac{F_1}{A_1} = \frac{F_2}{A_2}$$

OR

$$\frac{F_1}{F_2} = \frac{A_1}{A_2}$$

NOTE:

The cross-sectional areas of small piston and large piston should have the same units. There is no need of converting if the units are the same.

Examples:

1. The figure below shows a hydraulic press. The cross-sectional area of piston B is $80m^2$ and the cross-sectional area of A is $2.5m^2$.

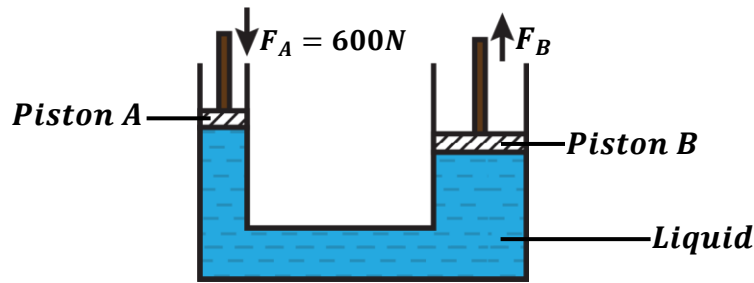

Find the force exerted on the piston B if a force of 600N is applied on piston A.

$$A_A = 2.5m^2,$$

$$A_B = 80m^2$$

Pressure at A = Pressure at B

$$\begin{aligned} \frac{F_A}{A_A} &= \frac{F_B}{A_B} \\ \frac{600}{2.5} &= \frac{F_B}{80} \\ F_B &= \frac{600 \times 80}{2.5} \\ F_B &= 19200N \end{aligned}$$

2. Calculate the force applied on the small piston of area $2cm^2$ if a mass of $80kg$ is to be lifted by a larger piston of area $10cm^2$.

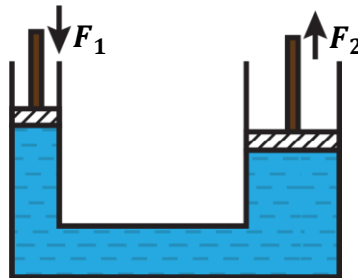

$$A_1 = 2cm^2, \quad A_2 = 10cm^2, \quad m = 80kg$$

$$F_2 = mg = (80 \times 10) = 800N$$

$$\begin{aligned} \frac{F_1}{F_2} &= \frac{A_1}{A_2} \\ \frac{F_1}{800} &= \frac{2}{10} \\ F_1 &= \frac{2 \times 800}{10} \\ F_1 &= 160N \end{aligned}$$

OR

$$\begin{aligned} \frac{F_1}{F_2} &= \frac{A_1}{A_2} \\ \frac{F_1}{800} &= \frac{2/10000}{10/10000} \\ F_1 &= \frac{0.0002 \times 800}{0.001} \\ F_1 &= 160N \end{aligned}$$

3. Given that the radius of a circular piston A is 14cm and radius of circular piston B is 28cm. If the force exerted on piston A is 77N, find the force exerted on piston B.

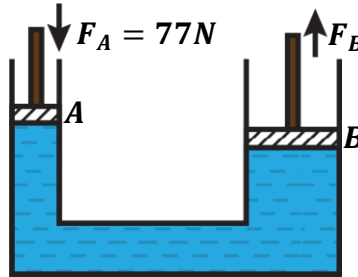

$$r_A = 14\text{cm}, \quad r_B = 28\text{cm},$$

$$\begin{aligned} \frac{F_A}{F_B} &= \frac{A_A}{A_B} \\ \frac{F_A}{F_B} &= \frac{\pi r_A^2}{\pi r_B^2} \\ \frac{77}{F_B} &= \frac{14^2}{28^2} \\ F_B &= \frac{77 \times 784}{196} \\ F_B &= 308\text{N} \end{aligned}$$

4. In a hydraulic press, a force of 400N is applied to a pump piston of area 0.1m^2 . The area of the ram piston is 4m^2 . Calculate;

- i) the pressure transmitted through the liquid.
ii) weight on the ram piston.

$$A_1 = 0.1\text{m}^2, \quad A_2 = 4\text{m}^2, \quad F_1 = 400\text{N}$$

i)

$$\begin{aligned} P_1 &= \frac{F_1}{A_1} \\ P_1 &= \frac{400}{0.1} \\ P_1 &= 4000\text{ Pa} \end{aligned}$$

ii)

Pressure at pump = Pressure at ram

$$\begin{aligned} P_1 &= P_2 \\ P_1 &= \frac{F_2}{A_2} \\ 4000 &= \frac{F_2}{4} \\ F_2 &= 4000 \times 4 \\ F_2 &= 16000\text{N (Weight)} \end{aligned}$$

5. A hydraulic press machine is used to raise a load, W, on a piston of cross-sectional area 100cm^2 by using an effort of 20N at a piston of cross-sectional area of 2cm^2 . Calculate load, W.

$$A_1 = 2\text{cm}^2, \quad A_2 = 100\text{cm}^2, \quad F_1 = 20\text{N}, \quad F_2 = W$$

$$\begin{aligned} \frac{F_1}{F_2} &= \frac{A_1}{A_2} \\ \frac{20}{W} &= \frac{2}{100} \\ W &= \frac{20 \times 100}{2} \\ W &= 1000\text{N} \end{aligned}$$

EXERCISE:

1. The area of the large piston of a hydraulic press is $10m^2$ and that of the smaller one is $0.25m^2$. A force of $100N$ is applied on the smaller piston. Calculate the force produced at the larger piston.
2. The area of a small piston of a hydraulic press is $0.5m^2$. If an effort of $250N$ is applied on the pump cylinder and raises a load of $20000N$, calculate the area of the piston at the ram cylinder.
3. In a hydraulic press, a force of $200N$ is applied to small circular piston of area $25cm^2$. If the hydraulic press is designed to produce a force of $5000N$, determine;
 - i) the area of the large piston.
 - ii) the radius of the large piston.
4. A hydraulic press has cylindrical pistons of radii $2cm$ and $0.4m$ respectively. Calculate the maximum load at the larger piston that can overcome a force of $78N$.
5. A hydraulic jack is used to lift a car by applying a force of $120N$ at the pump cylinder. If the area of the ram and pump piston is $100cm^2$ and $1m^2$ respectively. Calculate the force applied to the ram piston.
6. Calculate the weight, W raised by a force of $56N$ applied on a small piston of area $14m^2$. Take the area of the large piston to be $42m^2$.

HYDRAULIC BRAKE:

A hydraulic braking system is used in motor vehicles.

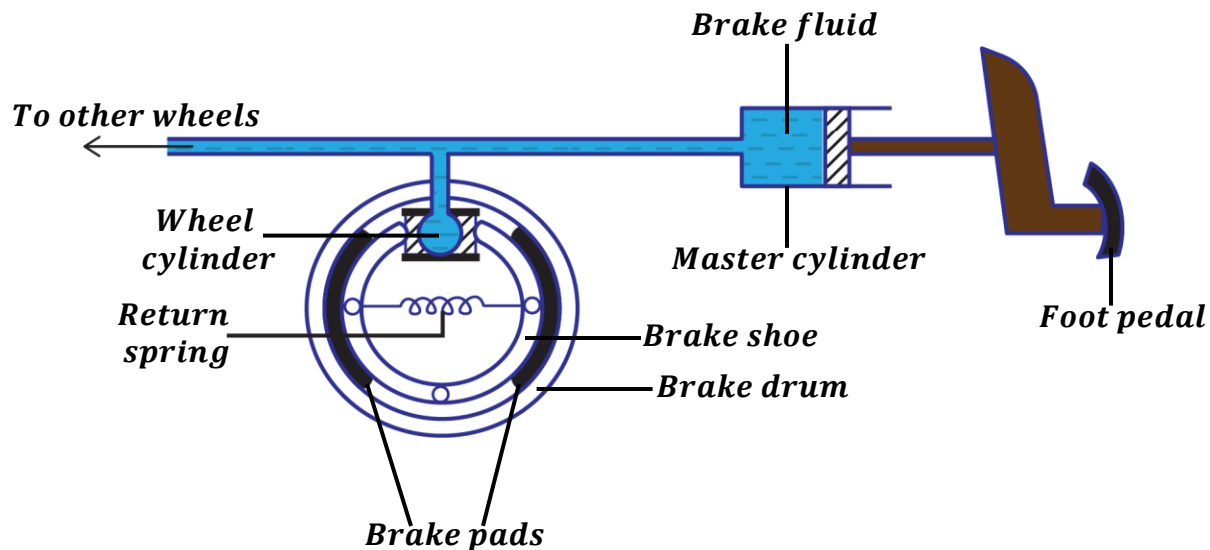
How a hydraulic brake works:

- When the driver pushes down the foot pedal, the force applied exerts pressure on the brake fluid in the master cylinder.
- This pressure is transmitted by the brake fluid to the wheel cylinder. This causes the pistons of wheel cylinders to push the brake shoes which in turn press the brake pad against the brake drum. The contact between the brake drum and brake pads stops the rotation of the wheels.
- When the force on the foot pedal is removed, the return spring pull back the brake shoe which then pushes the cylinder pistons back.

Properties of hydraulic fluids (brake fluid):

Any fluid to be used in hydraulic machines should have the following properties;

- The fluid should be incompressible. This enables pressure to be equally transmitted in all parts of the braking system.
- The fluid should have a low freezing point. This helps the fluid not to cool easily which may make it a thicker fluid thus not behaving well.
- The fluid should have a high boiling point. This helps the fluid not to warm up easily which may increase its compressibility.
- The fluid should not corrode the parts of the brake system.

Uses of hydraulic machines:

- ✓ Used to lift loads such as cars in garages. (Hydraulic Jack)
- ✓ Used to compress materials such as cotton, steel for easy transportation. (Hydraulic press)

ATMOSPHERIC PRESSURE



The air (mixture of gases) surrounding the earth is called “**atmosphere**”. This air surrounds us and everything on the earth’s surface.

The weight of air exerts pressure on all objects on the earth’s surface and this pressure is called atmospheric pressure.

Definition:

Atmospheric pressure is the pressure exerted by the weight of air on all objects on the earth’s surface.

❖ Atmospheric pressure is measured by an instrument called **Barometer**.

Variation of atmospheric pressure with number of air molecules (Air density):

The more the air molecules around an object, the more force exerted on the object hence exerting high pressure on the object. Therefore, pressure increases with increase in air molecules and pressure decreases with decrease in air molecules.

Variation of atmospheric pressure with altitude:

Atmospheric pressure increases with decrease in altitude (height) and vice versa.

The density of air above the earth’s surface decreases as altitude increases leading to a decrease in atmospheric pressure at high altitudes.

Therefore, atmospheric pressure is low at high altitudes (e.g. mountain peaks) and atmospheric pressure is high at low altitudes.

This effect explains why cooking takes long at higher altitudes (*See Book 2, Heat measurement*).

NOTE:

- ❖ At sea level, the value of atmospheric pressure is very large though we do not normally feel it because **blood pressure** is slightly greater than atmospheric pressure.
- ❖ A person may faint if he/she experiences a loss in blood pressure. The low blood pressure decreases the rate at which blood flows to the brain thus causing an insufficient blood flow to the brain.

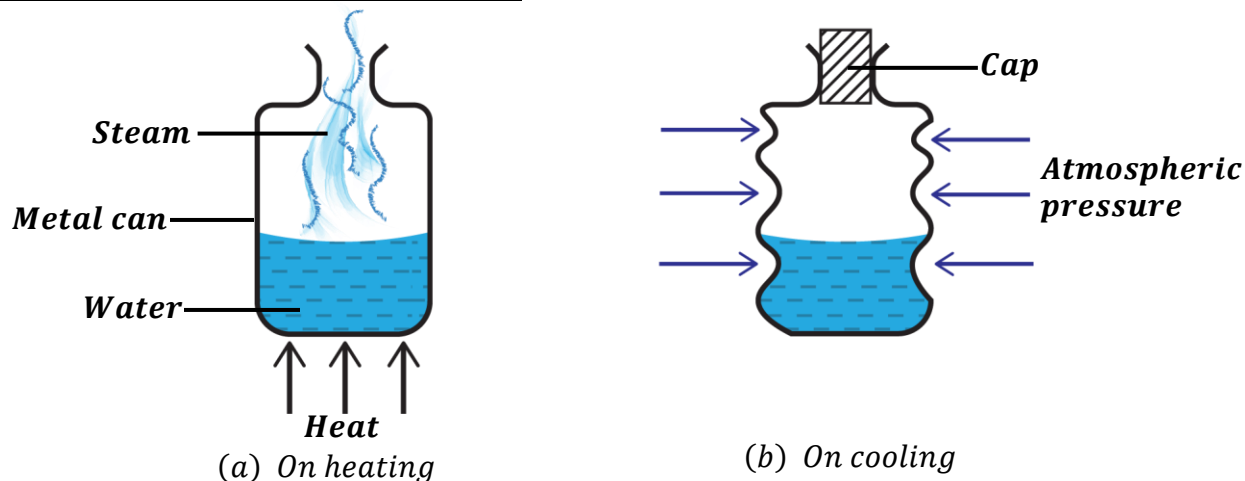
EXPERIMENT TO DEMONSTRATE ATMOSPHERIC PRESSURE
Crushing or Collapsing can experiment.

- An empty metal can is filled with some water and left uncovered.
- Water in the metal can is boiled for sometime until steam is produced.
- When the steam has driven out most of the air, the metal can is covered with a cap.
- Cool the metal can by pouring cold water over it.
- On cooling, steam condenses to water hence reducing air pressure inside the metal can.
- The metal can collapses inwards (crushes) because the atmospheric pressure outside the can is greater than the reduced air pressure the can.

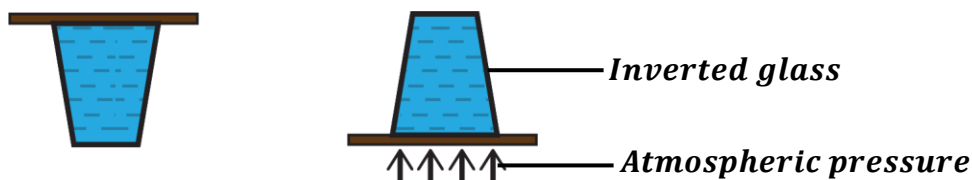
Other important demonstrations include;
a) Liquid trapped in inverted glass full of water:

- Pour water in a glass and make it full.
- Cover the entire glass with a smooth card.
- Put one hand on the card and the other hand holds the glass.
- Quickly turn the glass upside down and then remove the hand holding the card.

Observation:

- On releasing the card, it remains tightly fixed to the glass thus preventing water from pouring out. This is because water occupies most of the space which would have been occupied by air hence reducing air pressure inside the glass. Therefore, the atmospheric pressure outside the glass becomes greater than the inside air pressure thus acting strongly on the card.

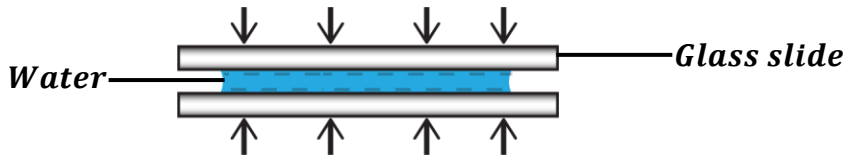
b) Sticking two wet glass slides together:

- One face of a glass slide is wetted with a water and a second glass slide is intimately placed on it.
- Try to move the glass slides apart.

Observation:

- It becomes difficult to separate the slides. This is because water expels air molecules between the slides thus reducing the air pressure between the two glass slides. Therefore, the atmospheric pressure acting outside the slides becomes greater than the air pressure in between the slides hence forcing the slides to stick tightly together.

Practical example

Explain why mountain climbers may suffer from nose bleeding at the top of a mountain.

On top of a mountain, atmospheric pressure is lower than that at the bottom. Due to the body's metabolism, the blood pressure may exceed the low atmospheric pressure at the top of the mountain. Since the blood capillaries are weaker, they may break due to the high pressure of the blood thus causing nose bleeding.

EXERCISE:

1. Explain why it is difficult to pull a cork of a flask when it is filled with water.
2. Explain why it is difficult to separate two microscopic glass slides when water is placed between them.
3. Explain why some people moving in aero-planes may suffer from headache and nose bleeding.
4. Explain why a fainted person is laid on his back with his feet raised above the chest.
5. A senior two student at Mbuye Farm school started nose bleeding while they were in a trip at the top of mountain Elgon.
 - a) Explain the possible reason for her nose bleeding.
 - b) Discuss how you can help her to stop the nose bleeding.
6. Explain why cooking takes a longer time than expected at a higher altitude.

APPLICATIONS OF ATMOSPHERIC PRESSURE

Atmospheric pressure is important in;

- ♦ Lift pump (Common borehole)
- ♦ Force pump
- ♦ Drinking straw
- ♦ Siphon
- ♦ Syringe, etc.

LIFT PUMP:

Lift pumps are used raise water from the wells or earth's surface. It is commonly known as a **bore hole**.

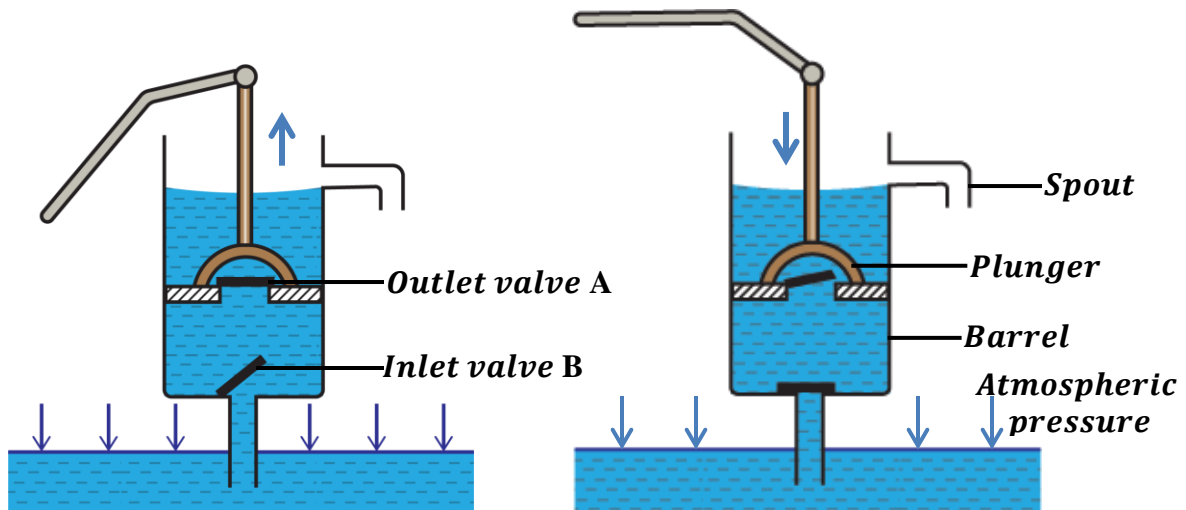

During the upstroke;

- the plunger moves upwards which reduces the pressure inside the barrel.
- outlet valve A closes and inlet valve B opens.
- water is pushed up the pipe through the inlet valve B by the atmospheric pressure acting on the surface of the water and occupies the space above the inlet valve B.

During the downstroke;

- the plunger moves downwards.
- inlet valve B closes and outlet valve A opens.
- water level in the barrel rises further through the outlet valve A and in the next repeated strokes, water reaches the spout and pours out.

Limitations of the lift pump

- ❖ The lift pump can't raise water beyond 10m. This is because atmospheric pressure is low in high altitudes. Atmospheric pressure can only support a water column of 10m.
- ❖ The lift pump can not work if there are leakages in the pipe.

FORCE PUMP:

The force pump was designed to overcome the limitations of the lift pump i.e. it can raise water to heights beyond 10m . It is commonly used to raise water from wetlands, lakes, wells to fill in storage tanks.

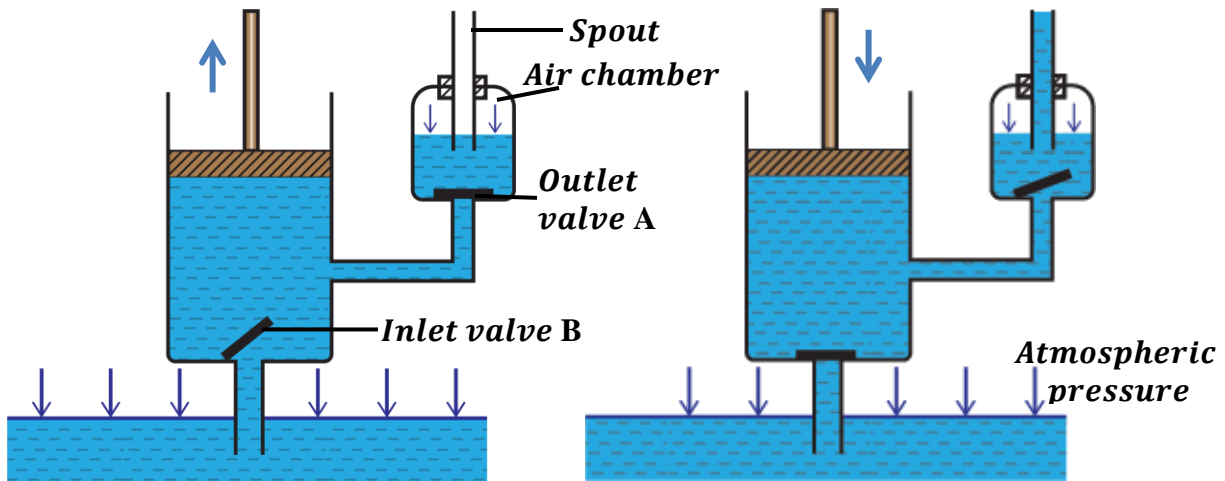
During the upstroke;

- the piston moves upwards which reduces the pressure inside the barrel.
- outlet valve A closes and inlet valve B opens
- water is pushed up the pipe through the inlet valve B by the atmospheric pressure acting on the surface of the water and occupies the space above the inlet valve B.

During the downstroke;

- the piston moves downwards thus compressing the water.
- inlet valve B closes and outlet valve A opens.
- water level in the barrel rises further and enters the air chamber through the outlet valve A and in the next repeated strokes, water reaches the spout and pours out.

NOTE:

The force pump enables continuous flow of water since the air in the air chamber is compressible. The height to which water is raised does not depend on the atmospheric pressure but it depends on;

- ❖ Force applied during the downstroke.
- ❖ The ability of the pump and its working parts to withstand pressure of the water in the chamber.

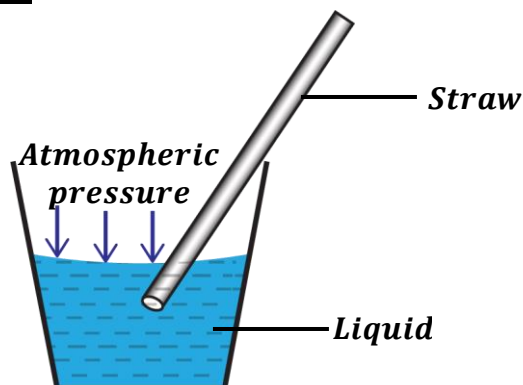
DRINKING STRAW:

- When air is sucked out from a straw dipped in a liquid, a vacuum is created and the air pressure inside the straw reduces. This causes the atmospheric pressure to be greater than the inside air pressure.
- The atmospheric pressure acting on the surface of the liquid forces the liquid to rise through the straw up to the mouth.

Question: Explain what happens when one drinks water using a straw with a hole.

Since the straw has a hole, the air keeps on entering through the hole. So no vacuum is created thus the air pressure inside the straw doesn't reduce. Therefore, the atmospheric pressure doesn't force water into the straw.

SYRINGE:

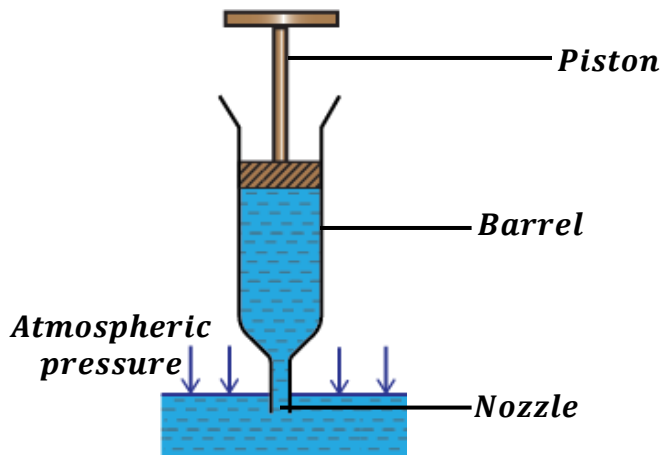

- When a piston is pulled outwards, a vacuum is created inside the barrel thus decreasing the air pressure inside the barrel. This causes the atmospheric pressure to be greater than air pressure inside.
- The atmospheric pressure acting on the surface of the liquid forces the liquid to rise through the nozzle into the barrel.

BICYCLE PUMP:

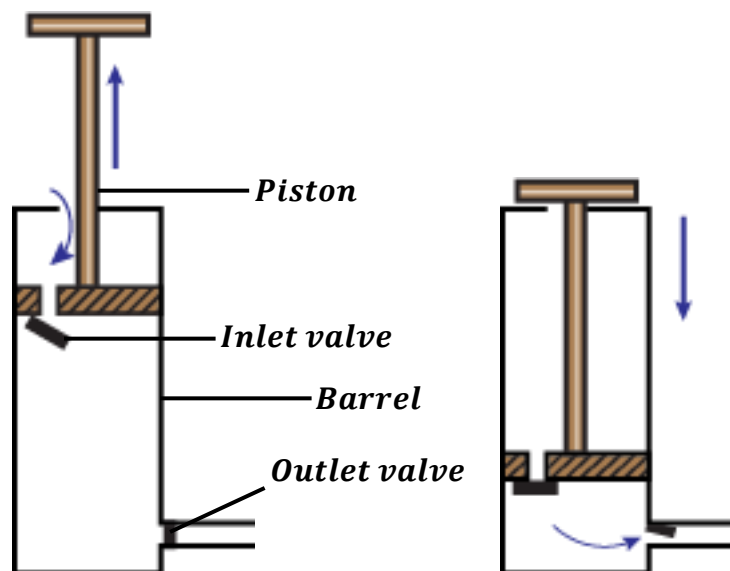

During the upstroke;

- the piston moves upwards which reduces the pressure inside the barrel.
- outlet valve closes and inlet valve opens.
- air is pushed into the barrel through the inlet valve by the atmospheric pressure outside.

During the downstroke;

- the piston moves downwards thus compressing the air inside the barrel.
- inlet valve closes and outlet valve opens.
- due to high pressure on the compressed air inside the barrel, air pushed out through the outlet valve to the tyre.

SIPHON:

This is a tube used to remove petrol from petrol tanks and also empty toilets.

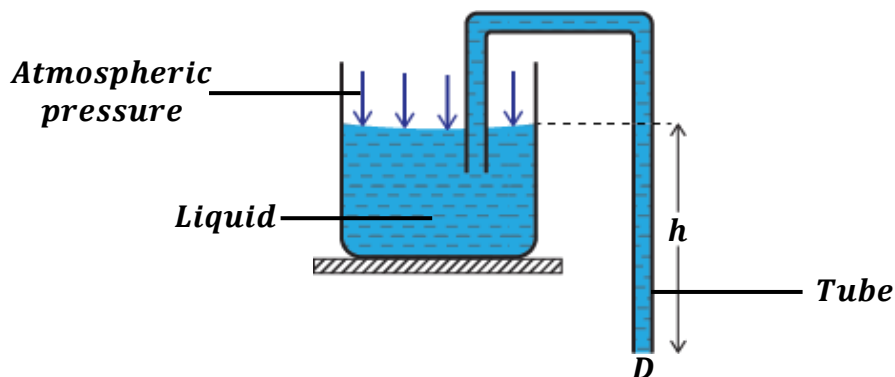

- One end of the tube D is put at a height below the surface of liquid. Therefore, pressure at this end, D is greater than the atmospheric pressure at the surface of liquid.
- Since the liquid at end D has a high pressure, it can easily flow out.
- The liquid will continue flowing out as long as tube end D is below the surface of the liquid.

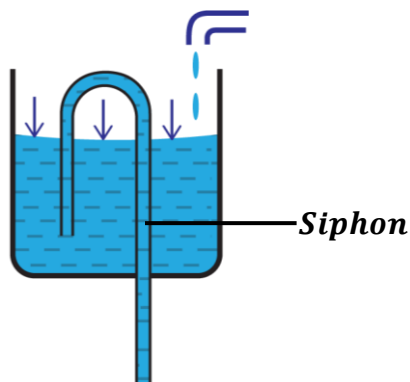
Application of the siphon principle
AUTOMATIC FLUSHING TANK

- Water drops slowly into the tank. Therefore, the water rises until it finds a bend.
- The action of the siphon starts and the tank is emptied.
- The action is then repeated again and again.

RUBBER SUCKER:

These are used in attaching car licenses to wind screens.
They are also used to lift papers to be fed into printers.

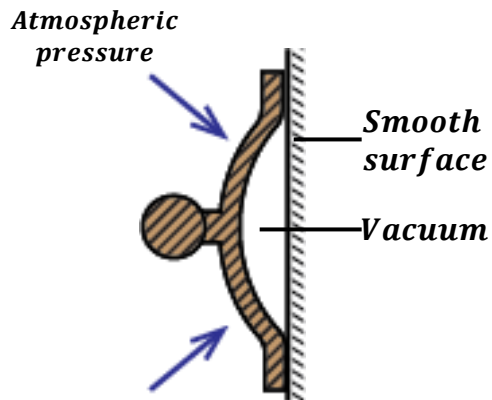

- A rubber sucker is moistened with water and then pressed on a smooth surface. The air between the rubber sucker and the smooth surface is decreased thus causing a partial vacuum.
- The atmospheric pressure outside the rubber sucker exceeds the air pressure in between the sucker and the surface.
- Therefore, the atmospheric pressure pushes the rubber sucker onto the smooth surface thus holding it firmly

EXERCISE:

1. Explain how it is able to fetch water from a borehole.
2. Explain how one can drink Soda using a straw.
3. Explain why one gets difficulties when using a straw with a hole to drink milk.
4. Explain how one is able to pump air inside a bicycle tyre using a bicycle pump.

MEASUREMENT OF ATMOSPHERIC PRESSURE

In a physics laboratory, atmospheric pressure is measured by an instrument called **Barometer**. There are three types of barometers namely;

- Simple mercury barometer (Nm^{-2})
- Fortin barometer (Pa)
- Aneroid barometer (*Atmospheres*)

How to construct (make) a simple mercury barometer in a laboratory:

- A dry glass tube is filled with mercury.
- The open end of the glass tube is covered with a finger and inverted into a beaker filled with mercury.
- The finger is then removed.
- When the finger is removed, the mercury level in the tube falls until it is equal to the atmospheric pressure.

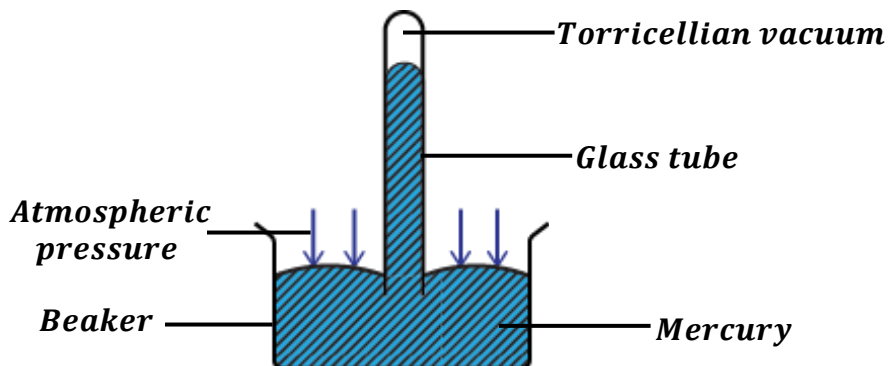

NOTE:

- The space left after the falling of the mercury level in the glass tube is called the **Torricellian vacuum**. This space is not a true vacuum because it has some mercury vapour.
- The height of mercury in the glass tube above the surface of mercury in the beaker is called the **barometric height**.
- After carrying out an experiment at sea level, atmospheric pressure is found to be equal to; **$1.03 \times 10^5 Pa$ or 1 atmosphere or 76cmHg or 760mmHg.**
- When the glass tube is tilted, the height of mercury (h) remains the same as shown below.

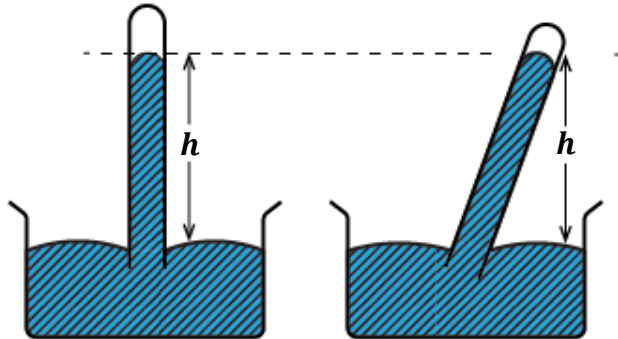
Reasons why mercury is more convenient to use in a barometer

- Mercury doesn't wet the glass tube and it is opaque. This makes it easier for someone to read the barometric height.
- Mercury has a high density thus giving a low barometric height hence a short glass tube (capillary tube) may be used.

Reasons why water is not more convenient to use in a barometer

- Water wets the glass tube and it is not opaque. This makes it not easier for someone to read the barometric height.
- Water has a low density thus giving a high barometric height hence a long glass tube (capillary tube) is required.

Examples:

Atmospheric pressure (H) = barometric height \times density of mercury \times acceleration due to gravity

$$H = h\rho g$$

1. If the barometer reads 76cmHg. Find the atmospheric pressure if the density of mercury is $13600kgm^{-3}$.

$$h = 76cm = \frac{76}{100} = 0.76m, \quad \rho = 13600kgm^{-3}, \quad g = 10ms^{-1}$$

Atmospheric pressure, $H = h\rho g$

Atmospheric pressure, $H = 0.76 \times 13600 \times 10$

Atmospheric pressure, $H = 103,360 Nm^{-2}$

2. The figure below shows a mercury barometer used to measure atmospheric pressure. (Density of mercury is 13600kgm^{-3})

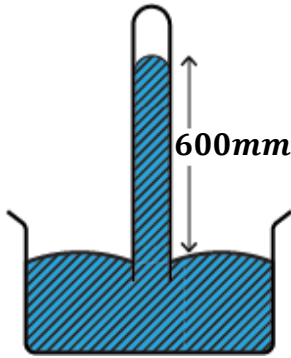

Calculate the atmospheric pressure;

- a) In cmHg

$$h = 600\text{mm} = \frac{600}{10} = 60\text{cm} \quad (1\text{cm} = 10\text{mm})$$

$$H = 60\text{cmHg}$$

- b) In Pascals (Nm^{-2})

$$h = 600\text{mm} = \frac{600}{1000} = 0.6\text{m}$$

$$\text{Atmospheric pressure, } H = h\rho g$$

$$H = 0.6 \times 13600 \times 10$$

$$H = 81600 \text{ Nm}^{-2}$$

3. The height of mercury column of the barometer supported by the atmospheric pressure is 76cm . Calculate the height of the column of water supported by the same atmospheric pressure. (Density of mercury is 13600kgm^{-3} and Density of water is 1000kgm^{-3})

For mercury;

$$h = 76\text{cm} = \frac{76}{100} = 0.76\text{m}$$

Atmospheric pressure, $H = h\rho g$

$$H = 0.76 \times 13600 \times 10$$

$$H = 103,360 \text{ Nm}^{-2}$$

For water;

$$h = ?$$

Atmospheric pressure, $H = h\rho g$

$$103360 = h \times 1000 \times 10$$

$$h = \frac{103360}{10000}$$

$$h = 10.336\text{m}$$

The above example explains why water is not used in barometers because it gives a high barometric height thus requiring a long glass or capillary tube.

HOW TO MEASURE HEIGHT OF A MOUNTAIN

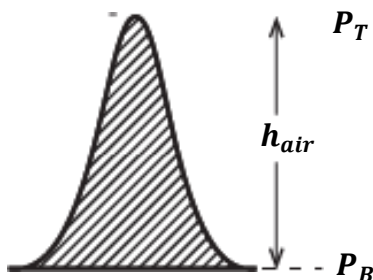

- Pressure at the top P_T and pressure at the bottom P_B are determined using a mercury barometer.
- The difference between the two pressures is got i.e. $\text{Pressure difference} = P_B - P_T$
- The pressure difference is equal to the pressure of air between the bottom and the top of the mountain.
- The height of the air h_{air} is calculated and it is equal to the height of the mountain.

Examples:

(Density of mercury is 13600kgm^{-3} and Density of air is 1.25kgm^{-3})

1. A mercury barometer reads a pressure of 75cmHg at the bottom of the mountain and 73.5cmHg at the top. Calculate the height of the mountain.

$$P_B = 75\text{cmHg}, \quad P_T = 73.5\text{cmHg}$$

In Nm^{-2} ;

$$P_B = h\rho g$$

$$P_B = \frac{75}{100} \times 13600 \times 10$$

$$P_B = 102,000 \text{ Nm}^{-2}$$

$$P_T = h\rho g$$

$$P_T = \frac{73.5}{100} \times 13600 \times 10$$

$$P_T = 99,960 \text{ Nm}^{-2}$$

But;

Pressure of air = Pressure difference

$$h_{\text{air}}\rho_{\text{air}}g = P_B - P_T$$

$$h_{\text{air}} \times 1.25 \times 10 = 102,000 - 99,960$$

$$12.5h_{\text{air}} = 2040$$

$$h_{\text{air}} = \frac{2040}{12.5}$$

$$h_{\text{air}} = 163.2\text{m}$$

Height of mountain = 163.2m

2. The pressure at the bottom of a mountain is 75.0cmHg . If one climbs a mountain 1Km high, what would be the pressure at the top?

$$P_B = 75.0\text{cmHg}, \quad P_T = ?, \quad h_{\text{air}} = 1\text{km} = 1000\text{m}$$

In Nm^{-2} ;

$$P_B = h\rho g$$

$$P_B = \frac{75}{100} \times 13600 \times 10$$

$$P_B = 102,000 \text{ Nm}^{-2}$$

Pressure of air = Pressure difference

$$h_{\text{air}}\rho_{\text{air}}g = P_B - P_T$$

$$1000 \times 1.25 \times 10 = 102,000 - P_T$$

$$12500 = 102,000 - P_T$$

$$P_T = 102,000 - 12500$$

$$P_T = 89,500\text{Nm}^{-2}$$

Converting it to cmHg

$$P_T = h\rho g$$

$$89500 = \frac{h}{100} \times 13600 \times 10$$

$$h = \frac{89500}{1360}$$

$$h = 65.8\text{cm}$$

$$P_T = 65.8\text{cmHg}$$

3. A barometer reads 638.7mmHg at the top of a hill. Calculate the pressure reading at the bottom if the hill is 2km high.

$$P_T = 638.7 \text{ mmHg}, \quad P_B = ?, \quad h_{\text{air}} = 2 \text{ km} = 2000 \text{ m}$$

In Nm^{-2} ;

$$P_T = h\rho g$$

$$P_T = \frac{638.7}{1000} \times 13600 \times 10$$

$$P_T = 86863.2 \text{ Nm}^{-2}$$

Pressure of air = Pressure difference

$$h_{\text{air}}\rho_{\text{air}}g = P_B - P_T$$

$$2000 \times 1.25 \times 10 = P_B - 86863.2$$

$$25000 = P_B - 86863.2$$

$$P_B = 25000 + 86863.2$$

$$P_B = 111863.2 \text{ Nm}^{-2}$$

Converting it to mmHg

$$P_B = h\rho g$$

$$111863.2 = \frac{h}{1000} \times 13600 \times 10$$

$$h = \frac{111863.2}{136}$$

$$h = 822.5 \text{ mm}$$

$$P_B = 822.5 \text{ mmHg}$$

EXERCISE:

(Density of mercury is 13600 kgm^{-3} and Density of air is 1.25 kgm^{-3})

1. The air pressure at the top of a mountain is 60 cmHg . Given that the height of the mountain is 850 m . Find the pressure at the bottom of the mountain in Nm^{-2} .
2. The barometric height at sea level is 76 cmHg while that at the top of a highland is 74 cmHg . What is the altitude?
3. The difference between the atmospheric pressure at the top and bottom of a mountain is $10,000 \text{ Nm}^{-2}$. Calculate the height of the mountain.
4. A barometer reads 76 cmHg and 73.8 cmHg at the bottom and top respectively. Find the height of the mountain.
5. A barometer is taken to the top of a mountain 440 m high. If the atmospheric pressure is 76 cmHg at the bottom, calculate the barometer reading.

PRESSURE IN FLUIDS

A fluid may be a liquid or a gas. The pressure of fluids is usually measured by an instrument known as a manometer.

MEASUREMENT OF PRESSURE IN GASES (GAS PRESSURE)

In a physics laboratory, the instrument used to measure gas pressure is called a **manometer**.

Manometer

A manometer consists of a U-tube or J-tube filled with a liquid. Water is used as a liquid in a manometer if the gas pressure to be measured is “low”. Mercury is used as a liquid in a manometer if the gas pressure to be measured is “high”.

Atmospheric pressure, H

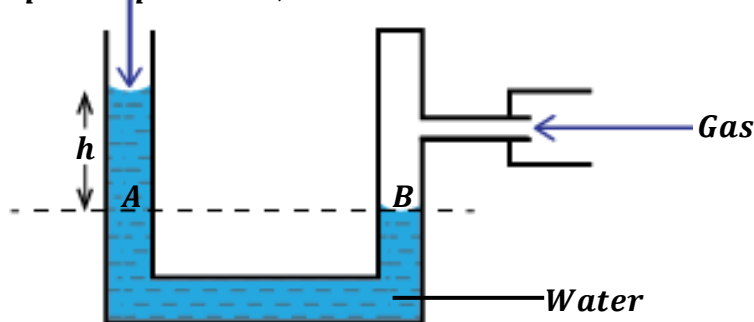

- One end of the manometer is closed and the other end is left open.
- The closed end is connected to the gas supply.
- When the gas is turned on, it exerts a pressure at point B causing a rise in the level of water in the open end of the manometer.
- The height, h due to the rise of water is obtained.
- Since pressure is transmitted equally (Pascal's principle), *pressure at A = Pressure at B*
- Therefore, ***Gas pressure at B = Atmospheric pressure + pressure of liquid (water) at A***

$$G_p = H + h$$

- In Pascals (Nm^{-2}), the heights must be in metres and $G_p = (H + h)\rho g$
- If the gas pressure is less than the atmospheric pressure, the level of the liquid in closed end of the manometer will be lower than that in the open end. Then $G_p = H - h$
- If the closed end of a manometer is opened, the trapped gas escapes and liquid levels in both arms of the manometer remain the same. Therefore, *gas pressure = atmospheric pressure*.

Examples:

1. The diagram below shows a water manometer used to measure gas pressure.

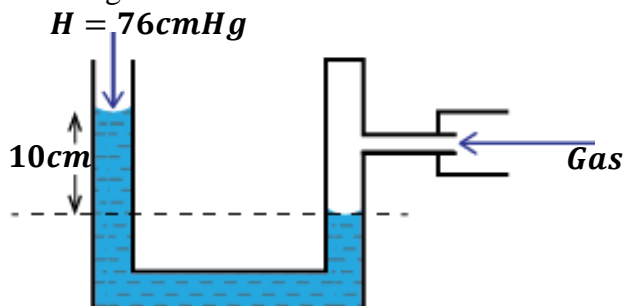

Find the gas pressure in

- (i) $cmHg$
- (ii) $mmHg$
- (iii) Pascals

(density of water = 1000kgm^{-3})

(i) *cmHg*
 $H = 76\text{cmHg}, h = 10\text{cmHg}$
 $G_p = H + h$
 $G_p = (76 + 10)\text{cmHg}$
 $G_p = 86\text{cmHg}$

(ii) *mmHg*
 Recall; $1\text{cm} = 10\text{mm}$
 $G_p = H + h$
 $G_p = (76 \times 10 + 10 \times 10)$
 $G_p = (760 + 100)\text{mmHg}$
 $G_p = 860\text{mmHg}$

(iii) Pascals
 Heights in metres.
 $G_p = (H + h)\rho g$
 $G_p = \left(\frac{76}{100} + \frac{10}{100}\right) \times 1000 \times 10$
 $G_p = (0.76 + 0.1) \times 10000$
 $G_p = 0.86 \times 10000$
 $G_p = 8600\text{Nm}^{-2}$

2. The figure below shows a mercury manometer. If the atmospheric pressure is 76cmHg and density of mercury is 13600kgm^{-3} , find the pressure of the gas in

- (i) *cmHg*
 (ii) Nm^{-2}

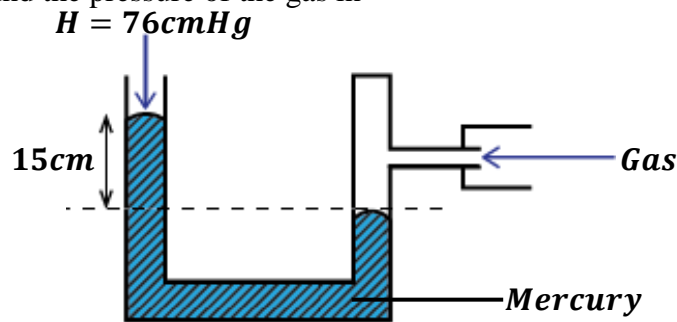

(i) *cmHg*
 $H = 76\text{cmHg}, h = 15\text{cmHg}$
 $G_p = H + h$
 $G_p = (76 + 15)\text{cmHg}$
 $G_p = 91\text{cmHg}$

(i) Nm^{-2}
 $G_p = (H + h)\rho g$
 $G_p = \left(\frac{76}{100} + \frac{15}{100}\right) \times 13600 \times 10$
 $G_p = (0.76 + 0.15) \times 136000$
 $G_p = 0.91 \times 136000$
 $G_p = 123760\text{Nm}^{-2}$

3. The diagram below shows a manometer used to measure gas pressure. Find the gas pressure if the atmospheric pressure is 76cmHg and density of mercury is 13600kgm^{-3} .

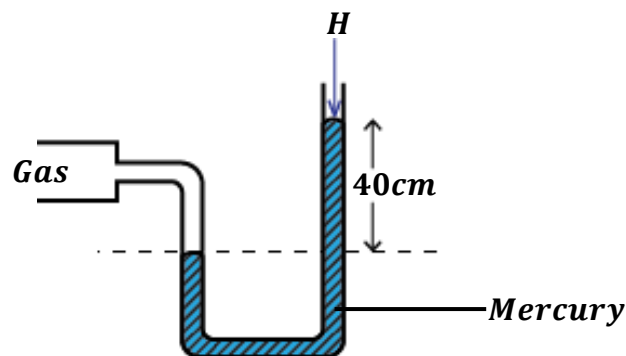

$$G_p = (H + h)\rho g$$

$$G_p = \left(\frac{76}{100} + \frac{40}{100}\right) \times 13600 \times 10$$

$$G_p = (0.76 + 0.4) \times 136000$$

$$G_p = 1.16 \times 136000$$

$$G_p = 157,760\text{Nm}^{-2}$$

4. The figure below shows a J-tube containing mercury used to measure gas pressure.
(Atmospheric pressure = 76cmHg and density of mercury is 13600kgm^{-3})

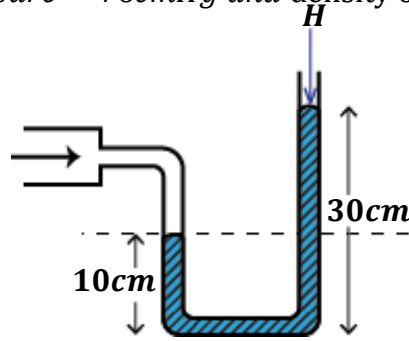

Find the pressure in;

(i) *cmHg*

$$H = 76\text{cmHg},$$

$$h = 30 - 10 = 20\text{cm}$$

$$G_P = H + h$$

$$G_P = (76 + 20)\text{cmHg}$$

$$G_P = 96\text{cmHg}$$

(ii) *mmHg*

Recall; $1\text{cm} = 10\text{mm}$

$$G_P = H + h$$

$$G_P = (76 \times 10 + 20 \times 10)$$

$$G_P = (760 + 200)\text{mmHg}$$

$$G_P = 960\text{mmHg}$$

(iii) Pascals

Heights in metres.

$$G_P = (H + h)\rho g$$

$$G_P = \left(\frac{76}{100} + \frac{20}{100}\right) \times 13600 \times 10$$

$$G_P = (0.76 + 0.2) \times 136000$$

$$G_P = 0.96 \times 136000$$

$$G_P = 130,560\text{ Pa}$$

5. The figure below shows a mercury manometer connected to a gas supply tank. Determine the pressure of the gas in Nm^{-2} .

(Atmospheric pressure = 76cmHg and density of mercury is 13600kgm^{-3})

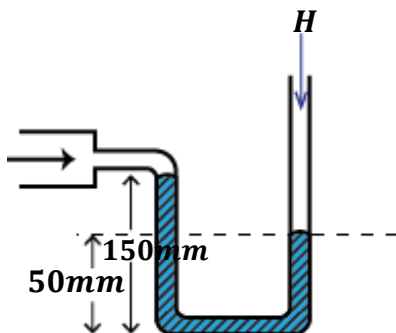

Level of liquid is lower in open end than closed end

$$h = 150 - 50 = 100\text{mm}$$

$$G_P = (H - h)\rho g$$

$$G_P = \left(\frac{76}{100} - \frac{100}{1000}\right) \times 13600 \times 10$$

$$G_P = (0.76 - 0.1) \times 136000$$

$$G_P = 0.66 \times 136000$$

$$G_P = 89,760\text{ Pa}$$

6. In the figure below, a fixed mass of dry air is trapped in bulb A. Calculate the total pressure of the air in A given that Atmospheric pressure = 76cmHg and density of mercury is 13600kgm^{-3}

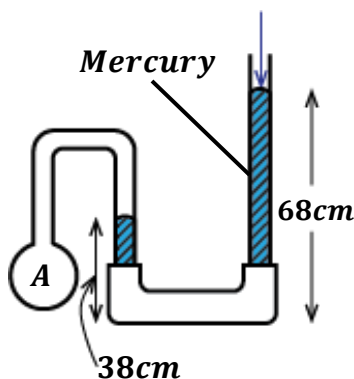

$$h = 68 - 38 = 30\text{cm}$$

$$G_P = (H + h)\rho g$$

$$G_P = \left(\frac{76}{100} + \frac{30}{100}\right) \times 13600 \times 10$$

$$G_P = (0.76 + 0.3) \times 136000$$

$$G_P = 1.06 \times 136000$$

$$G_P = 144,160\text{ Pa}$$

NOTE:

Sometimes, the atmospheric pressure may be given in **Pascals** or Nm^{-2} . Therefore, there is no need of first finding the atmospheric pressure.

7. Calculate the gas pressure if a mercury manometer reads $86cmHg$.

(Atmospheric pressure = $1.03 \times 10^5 Pa$ and density of mercury is $13600kgm^{-3}$)

Gas pressure = Atmospheric pressure + Pressure of the liquid

$$G_p = H + h\rho g$$

$$G_p = 1.03 \times 10^5 + \left(\frac{86}{100} \times 13600 \times 10 \right)$$

$$G_p = 103000 + 116960$$

$$G_p = 219,960 Pa$$

8. A man blows air in one end of a water U-tube manometer until the level differ by $40.0cm$. If the Atmospheric pressure = $1.0 \times 10^5 Nm^{-2}$ and density of water is $1000kgm^{-3}$. Calculate the pressure of air.

Gas pressure = Atmospheric pressure + Pressure of the liquid

$$G_p = H + h\rho g$$

$$G_p = 1.0 \times 10^5 + \left(\frac{40.0}{100} \times 1000 \times 10 \right)$$

$$G_p = 100000 + 4000$$

$$G_p = 104,000 Pa$$

9. A mercury manometer connected to a gas supply mains $70mmHg$. Calculate the gas pressure in Nm^{-2} . (Atmospheric pressure = $103360 Pa$ and density of mercury is $13600kgm^{-3}$)

Gas pressure = Atmospheric pressure + Pressure of the liquid

$$G_p = H + h\rho g$$

$$G_p = 103360 + \left(\frac{70}{1000} \times 13600 \times 10 \right)$$

$$G_p = 103360 + 9520$$

$$G_p = 112,880 Pa$$

10. The figure below shows a gas trapped by a mercury column in a J-tube. The atmospheric pressure is $1.0 \times 10^5 Pa$ and density of mercury is $13600kgm^{-3}$.

- a) Find the pressure at which the gas is.

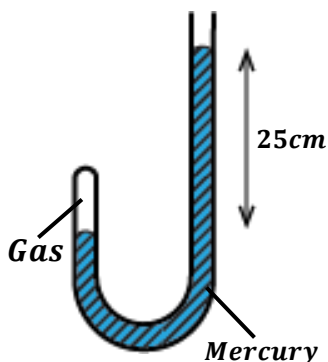

$$G_p = H + h\rho g$$

$$G_p = 1.0 \times 10^5 + \left(\frac{25}{100} \times 13600 \times 10 \right)$$

$$G_p = 100000 + 34000$$

$$G_p = 134,000 Pa$$

b) What would happen if the closed end of the J-tube was opened.

If the closed end of the J-tube manometer is opened, the trapped gas escapes and liquid levels in both arms of the manometer remain the same. Therefore, gas pressure = atmospheric pressure.

COMPARISONS OF DENSITIES OF LIQUIDS THAT DON'T MIX
(HARE'S APPARATUS)

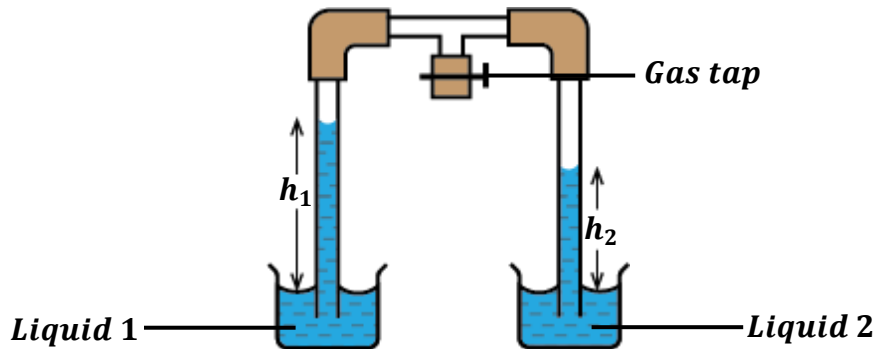

- Liquids of different densities are poured in the glass beakers as shown above.
- When the gas tap is opened, air is let out and each liquid rises to different heights h_1 and h_2 .
- Since the liquids are pressurized by the same gas;

$$\text{Pressure on liquid 1} = \text{Pressure on liquid 2}$$

$$h_1\rho_1g = h_2\rho_2g$$

Examples:

1. Two liquids were sucked up in two identical tubes as shown below.

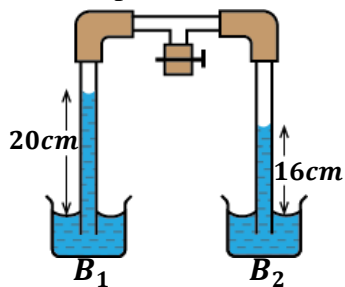

Given that liquid in beaker B_1 is water. Calculate the density of liquid in beaker B_2 .
(density of water is 1000kgm^{-3})

$$\text{Pressure on liquid 1} = \text{Pressure on liquid 2}$$

$$h_1\rho_1g = h_2\rho_2g$$

$$20 \times 1000 \times 10 = 16 \times \rho_2 \times 10$$

$$200,000 = 160\rho_2$$

$$\rho_2 = \frac{200000}{160}$$

$$\rho_2 = 1250 \text{ kgm}^{-3}$$

2. The figure below shows a mercury manometer having two liquids. Find the density of paraffin. (Density of water is 1000kgm^{-3})

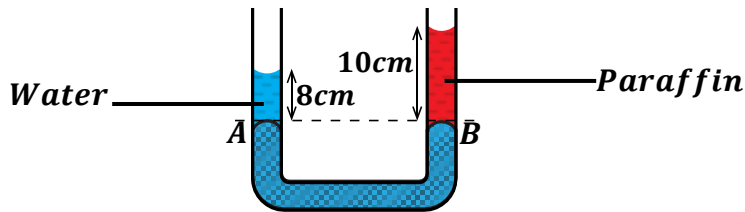

Pressure on water = Pressure on Paraffin

$$h_w \rho_w g = h_p \rho_p g$$

$$8 \times 1000 \times 10 = 10 \times \rho_p \times 10$$

$$80,000 = 100\rho_p$$

$$\rho_p = \frac{80000}{100}$$

$$\rho_p = 800 \text{ kgm}^{-3}$$

3. In the figure below, find the density of mercury given that density of water is 1000kgm^{-3} .

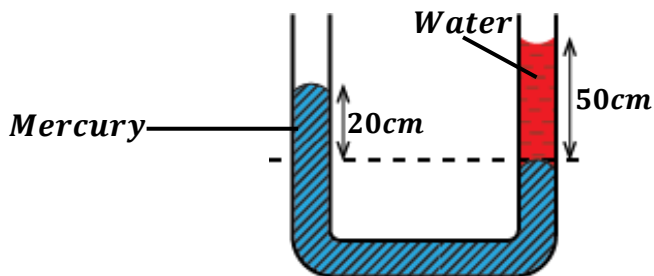

Pressure on mercury = Pressure on water

$$h_m \rho_m g = h_w \rho_w g$$

$$20 \times \rho_m \times 10 = 50 \times 1000 \times 10$$

$$200\rho_m = 500,000$$

$$\rho_m = \frac{500,000}{200}$$

$$\rho_m = 2500 \text{ kgm}^{-3}$$

4. The levels of mercury in a manometer are found to be as shown below. Given that density of water is 1000kgm^{-3} , find the density of alcohol.

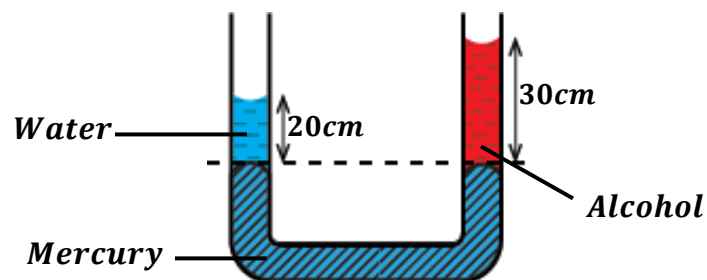

Pressure on water = Pressure on Alcohol

$$h_w \rho_w g = h_a \rho_a g$$

$$20 \times 1000 \times 10 = 30 \times \rho_a \times 10$$

$$200,000 = 300 \rho_a$$

$$\rho_a = \frac{200000}{300}$$

$$\rho_a = 666.7 \text{ kgm}^{-3}$$

EXERCISE:

- The levels of liquids in the arms of a mercury manometer are as shown in the figure below.

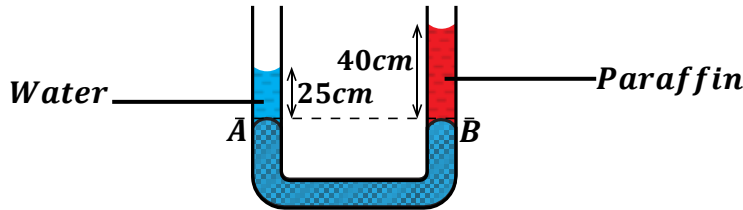

If the density of water is 1000 kgm^{-3} , determine the density of paraffin.

- In the figure below, determine the pressure exerted by the gas.
(Atmospheric pressure = 76 cmHg and density of mercury is 13600 kgm^{-3})

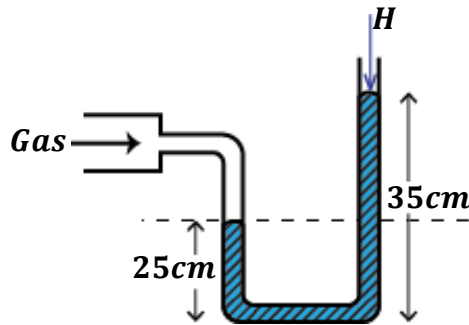

- In the figure below, determine the pressure of the gas in.
(Atmospheric pressure = 76 cmHg and density of mercury is 13600 kgm^{-3})

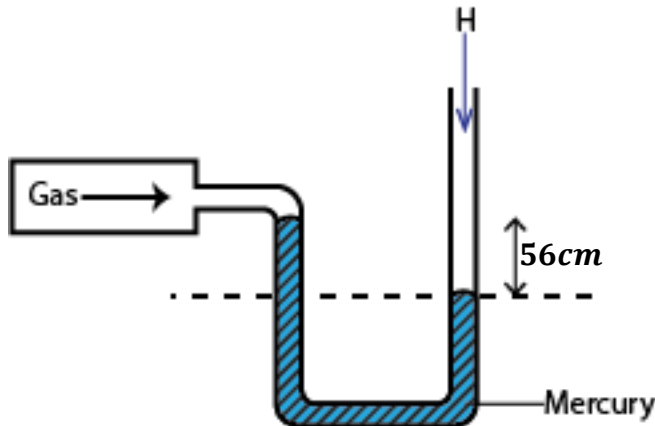

- cmHg
- mmHg
- Pa

4. The level of mercury in the arms of the manometer shown below is equal.
(density of water is 1000kgm^{-3})

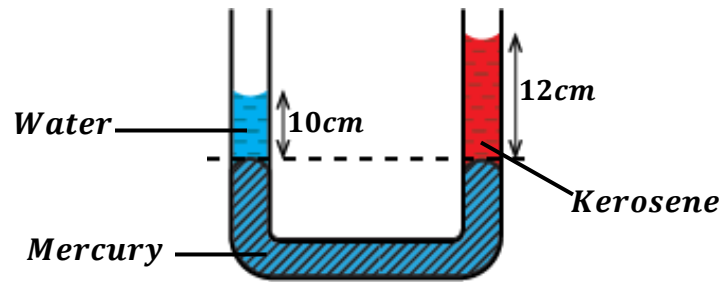

Determine the;

- (i) Density of kerosene.
 - (ii) Relative density of kerosene.
5. The U-tube in the figure below contains mercury and oil of density 13600kgm^{-3} and 600kgm^{-3} respectively. Calculate the height of the oil column.

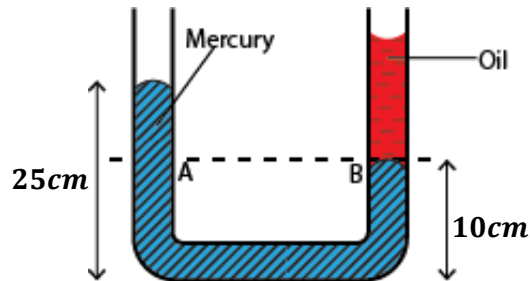

6. The diagram below shows air trapped by a column of mercury in a J-tube.
(Atmospheric pressure = 76cmHg and density of mercury is 13600kgm^{-3})
Calculate the pressure of the enclosed air.

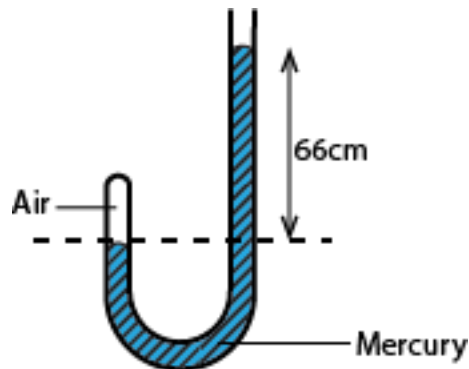

MODERN PHYSICS

The structure of an atom:

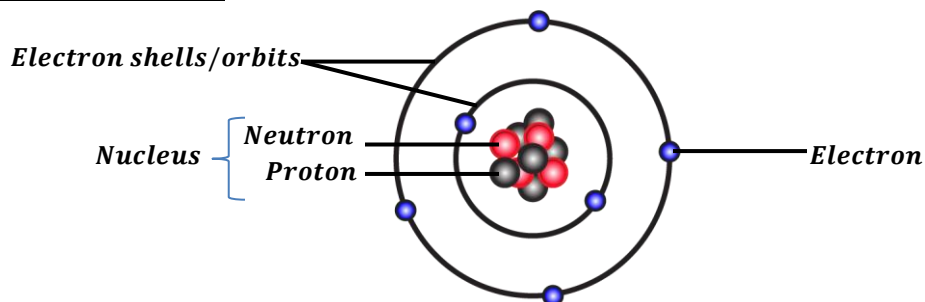

An atom is the smallest particle of an element that can take part in a chemical reaction. An atom consists of three particles namely;

- Electrons
- Neutrons
- Protons

An atom is made of a central part called the nucleus around which electrons revolve. The nucleus is positively charged because it consists of protons which are positively charged and neutrons which have no charge. The properties of the particles of an atom are as shown in the table below.

Name	Symbol	Mass	Charge
Protons	P	1	Positive
Neutrons	n	1	No charge
Electrons	e	0	Negative

Note: The number of protons in the nucleus is equal to the number electrons around the nucleus and since they have opposite charges the atom has no charge.

Likely question: *Describe the model/structure of an atom*

Atomic number, Z:

This is the number of protons in the nucleus of an atom.

$$\text{Atomic number, } Z = \text{Number of protons}$$

Mass number [atomic mass], A: (nucleon number):

This is the total number of protons and neutrons in the nucleus of an atom.

$$\text{Mass number} = \text{Number of protons} + \text{Number of neutrons}$$

$$A = Z + n$$

If an atom of an element X is represented as

$${}^A_ZX \text{ where } A \text{ is the mass number and } Z \text{ is the atomic number}$$

Examples:

1. Given a chloride atom ${}^{35}_{17}\text{Cl}$. Find the number of electrons in the atom.

$$A = Z + n \quad \text{where } A = 35, Z = 17$$

$$n = 35 - 17$$

$$n = \mathbf{18 \text{ neutrons}}$$

$$\text{Number of electrons} = \text{Number of protons} = \text{Atomic number } Z = \mathbf{17 \text{ electrons}}$$

2. State the composition of the atom ${}_{92}^{235}\text{U}$

Atomic number = 92

Mass number = 235

Number of neutrons = 235 – 92 = 143

Number of electrons = 92

Number of protons = 92

ISOTOPES:

These are atoms of the same element with the same atomic number but different mass numbers. Therefore, isotopes of an element have the same number of protons and electrons and different number of neutrons

Examples of isotopes are:

Chlorine; ${}_{17}^{35}\text{Cl}$, ${}_{17}^{36}\text{Cl}$, ${}_{17}^{37}\text{Cl}$

Carbon; ${}_{6}^{12}\text{C}$, ${}_{6}^{13}\text{C}$, ${}_{6}^{14}\text{C}$

Hydrogen; ${}_{1}^1\text{H}$, ${}_{1}^2\text{H}$, ${}_{1}^3\text{H}$

RADIOACTIVITY:

This is the spontaneous disintegration of unstable nucleus of an atom to form a stable nucleus with emission of radiations.

There are three radiations emitted by radioactive nucleus namely:

- Alpha particles, α .
- Beta particles, β .
- Gamma rays, γ .

Elements that undergo radioactivity are called **radioactive elements/nuclides**.

Heavy nuclides are generally unstable hence radioactivity ensures that they reach a stable state.

Examples of radioactive elements are:

- Uranium (U)
- Radium (Ra)
- Polonium (Po),
- Protactinium (Pa)
- Etc.

Radioisotopes:

These are radioactive atoms of the same element having the same atomic number but different mass number.

TYPES OF RADIATIONS

Alpha particle, α :

Alpha particle is a high speed helium nucleus (${}^4_2\text{He}$)

Alpha particles have a mass number of 4 and atomic number of 2 i.e. two protons and two neutrons and they carry a positive charge. They have no electrons to balance the two positively charged protons.

Properties of alpha particles:

- They are helium nuclei
- They are slightly deflected by both magnetic and electric fields because of their large mass.
- They are positively charged.
- They have the greatest ionizing power.
- They have the least penetrating power.
- They are stopped by a thick sheet of paper.
- They have a very short range in air.
- They affect the photographic films.
- They have speed less than the speed of light.
- They cause fluorescence when incident on fluorescent substance.

Alpha decay:

When a nuclide undergoes an alpha decay, it loses two protons and two neutrons.

Therefore its mass number reduces by four and its atomic number reduces by two and the daughter nuclide is two steps to the left in the periodic table.

Given that a radioactive element, ${}^A_Z\text{X}$ undergoes an alpha decay to form element **Y**. Then the nuclear reaction equation is given by;

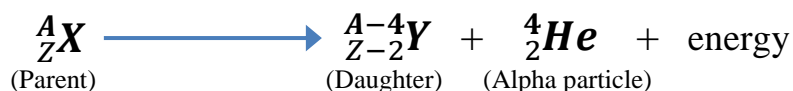

Examples:

1. Radium (**Ra**) decays to become radon (**Rn**) according to the equation



2. Uranium (**U**) decays to become thorium (**Th**) according to the equation



Question 1:

A radioactive substance ${}^{22}_6\text{X}$ undergoes decay and emits an alpha particle to form nuclide Y. Write an equation for the process.



Beta particle, β :

A beta particle is a high-speed electron emitted from the nucleus of a radioactive element.

Beta particles have no mass number and carry a negative charge (${}_{-1}^0e$).

A beta particle is produced as a result of one of the neutrons changing to a proton.



Properties of beta particles:

- They are negatively charged.
- They are lighter since they have negligible mass
- They are easily deflected by both magnetic and electric fields
- They have greater penetrating power than alpha particles because of their high speed.
- They have less ionizing power than alpha particle.
- They can be stopped by a thin sheet of aluminium.
- They have a greater range in air than alpha particles.
- They cause fluorescence when incident on fluorescent substance.
- They are electrons.

Beta decay:

When a nuclide undergoes beta decay its mass number does not change but its atomic number increases by one. The daughter nuclide is one step to the right in the periodic table.

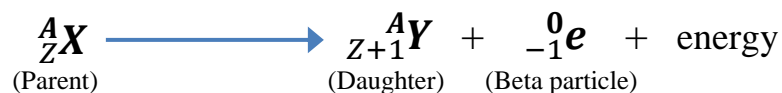
Given that a radioactive element, A_ZX undergoes a beta decay to form element Y. Then the nuclear reaction equation is given by:

Examples:

1. Carbon-14 decays to Nitrogen according to the equation



2. ${}^{235}_{92}U$ decays by emitting 3 beta particles to form a daughter nuclide P. Find the atomic and mass number of P.



Mass number = 235, Atomic number = 95

Gamma rays, γ :

Gamma ray is an electromagnetic radiation with a very short-wave length.

Gamma rays have no mass number and carry no charge.

Gamma rays are produced when an excited atomic nucleus loses energy and the energy is given out as gamma rays.

Properties of gamma rays:

- They are not charged.
- They travel at a speed of light since they are electromagnetic radiations.
- They are not deflected by both magnetic and electric fields since they are not charged.
- They have the least ionizing power.
- They have the greatest penetrating power.
- They undergo interference and diffraction.
- They cause fluorescence when incident on fluorescence substances.
- They have the greatest range in air.
- They are stopped by thick block of lead.

Gamma decay:

Gamma rays are not particles, therefore when nuclide emits gamma rays its atomic number and its mass number do not change but the nucleus becomes more stable.

Given that a radioactive element, A_ZX undergoes a gamma decay to form a stable element **X**. Then the nuclear reaction equation is given by:

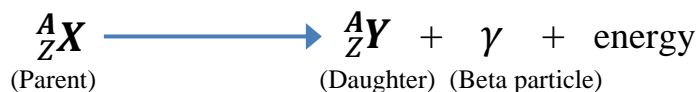
Note:

The change of an element to another element is called **Transmutation**.

Examples:

1. Radium ${}^{226}_{88}\text{Ra}$ loses 5 alpha particles and 4 beta particles and is converted into a new stable element, an isotope of lead *Pb*. Find the mass number and atomic number of this isotope.

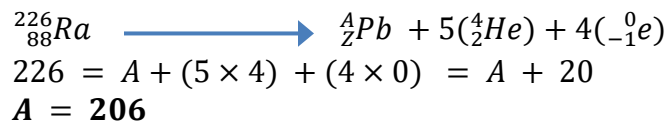

$$\begin{array}{l} \text{Also, } 88 = Z + (5 \times 2) + (4 \times -1) = Z + 10 - 4 \\ \mathbf{Z = 82} \end{array}$$

2. Thorium ${}^{232}_{90}\text{Th}$ is converted into Radium ${}^{224}_{88}\text{Ra}$ by radioactivity transformation below. How many α and β emissions have taken place?

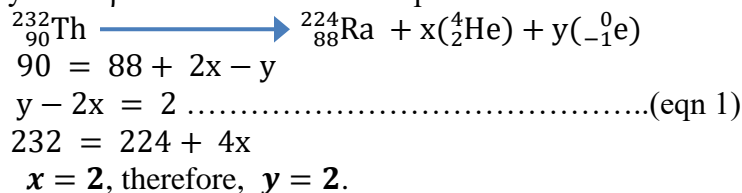

There are 2α - particles and 2β - particles.



Penetrating power of the radiations:

Alpha particles have the least penetrating power and can be stopped by a thick sheet of paper. Beta particles have a greater penetrating power than alpha particles and can be stopped by a thin sheet of aluminium while gamma rays have the greatest penetrating power and can be stopped by thick block of lead.

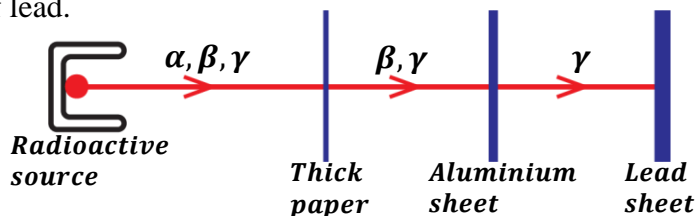

Ionizing power of the radiations:

Alpha particles produce straight traces because they are heavy and they cause greater ionization of the air through which they pass.

Beta particles produce irregular and light traces.

Gamma rays do not produce traces but leave hairy traces after colliding with the air molecules since they have a least ionization power.

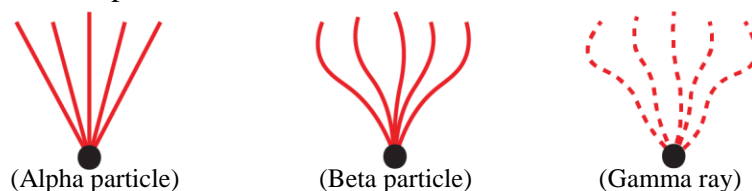

Deflection of the radiations in an electric field:

When the radiations from a radioactive nucleus are passed through a strong electric field;

- The beta particles are deflected towards a positive plate showing that they carry a negative charge.
- Alpha particles are deflected towards a negative plate in the direction opposite to that of beta particles showing that alpha particles carry a positive charge.
- The gamma rays are not deflected at all showing that they carry no charge.

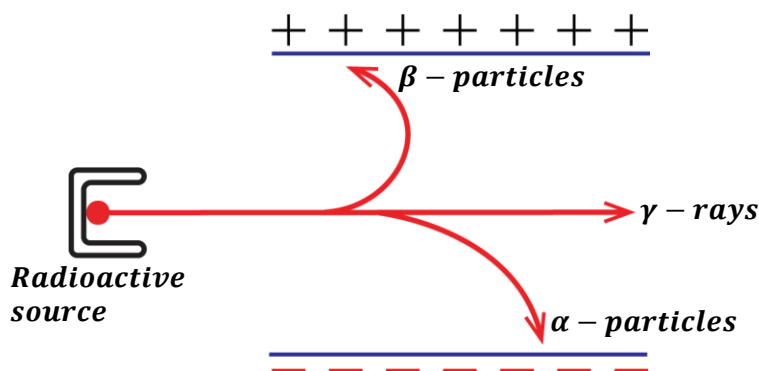

Deflection of the radiations in a magnetic field:

Alpha particles are deflected in a direction towards the South Pole while beta particles are deflected towards the North Pole.

Alpha particles are less deflected than beta particles implying that alpha particles are heavier than beta particles. The gamma rays are not deflected in the magnetic field implying that they have no charge.

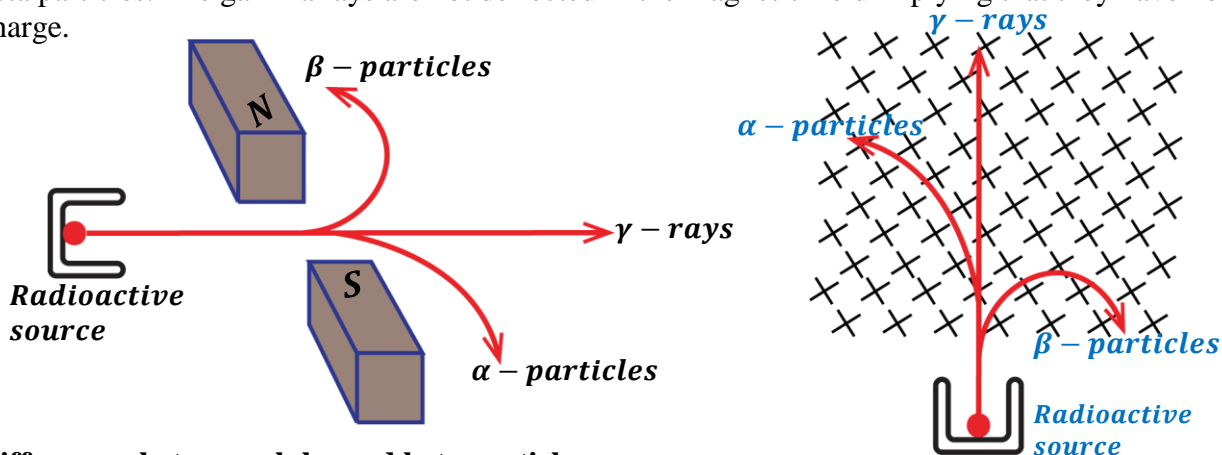

Differences between alpha and beta particles

ALPHA PARTICLES	BETA PARTICLES
<ul style="list-style-type: none"> ▪ Are helium atoms. ▪ They are positively charged. ▪ Deflected towards the negative plate in electric field. ▪ Deflected towards south pole in magnetic field. ▪ Stopped by thick sheet of paper. ▪ They are heavier. 	<ul style="list-style-type: none"> ▪ Are electrons. ▪ They are negatively charged. ▪ Deflected towards positive plate in an electric field. ▪ Deflected towards the north pole in a magnetic field. ▪ Stopped by thin sheet of aluminium. ▪ They are lighter.

Similarities between Alpha and Beta particles

- Both cause ionization of gases
- Both have charges.
- Both are deflected by electric field.
- Both are deflected by magnetic field.
- Both penetrate matter.

Uses of radioactivity:

a) Medical uses:

- ✓ Detection of broken bones.
- ✓ Detection of cancer cells and treating them.
- ✓ Used for sterilization of medical instruments
- ✓ Detection of brain tumors
- ✓ Detecting amount of blood in a patient

b) Industrial uses:

- ✓ Used to measure fluid flow in pipes in industries.
- ✓ Used to provide source of energy [electricity].
- ✓ Used in hardening polythene and petroleum.
- ✓ Used in food preservation.
- ✓ Used in detecting oil leakages in oil pipes.
- ✓ Used to measure the thickness of the metal sheet.

c) Agricultural uses:

- ✓ Used to produce new varieties of plants with new characteristics.
- ✓ Used to study the rate of uptake of fertilizers by plants.
- ✓ Used in pest control.

d) Archeological uses

- ✓ Used in determining the age of fossils (carbon-dating)
- ❖ *Every living thing (plant or animal) has a certain constant quantity of carbon -14 elements (isotope). When the plant or animal dies this isotope begins decaying and the rate of disintegration decreases with time. So, when a fossil is obtained the rate of disintegration is determined, and this is used to calculate the age of the fossil. i.e. when the plant or animal died, which would show when that type of plant or animal existed.*

HEALTH HAZARDS / DANGERS OF RADIOACTIVITY:

- Radiations cause skin burns.
- Radiations cause blood cancer.
- Radiations cause sterility [inability to produce].
- Radiations cause low body resistance to normal diseases.
- Radiations cause genetic changes [mutation].
- Radiations destroy body cells.
- Radiations damage eye sight and body tissues.

Safety precautions when handling radioactive elements:

- They should be handled using long pair of tongs.
- They should be transported in thick lead containers.
- You should avoid unnecessary exposure to the radiations.
- You should wear protective clothing when handling radioactive elements.
- You should not eat or drink where radioactive sources are in use.
- You should cover any wound before using radioactive source.

Background radiations:

These are ionizing radiations from a variety of natural and artificial sources that are always present in the environment.

Natural sources of background radiations:

Natural sources of background radiation include the following:

Cosmic Radiation:

These are radiations that reach the Earth from space.

The sun is a major source of cosmic rays. Cosmic rays originating from the sun, stars and other major events in outer space are continuously striking the Earth. The majority of these cosmic rays are absorbed by the Earth atmosphere but the more energetic radiations interact with the atoms in the atmosphere creating energetic neutrons.

Terrestrial Radiation:

These are radiations from radioactive materials that exist naturally in soil and rock.

E.g. radiations from uranium, thorium, and radium. Some rocks are radioactive and give off radioactive radon gas. Essentially all air contains radon. In addition, water contains small amounts of dissolved uranium and thorium, and all organic matter (both plant and animal) contains radioactive carbon and potassium. Some of these materials are ingested with food and water, while others (such as radon) are taken in.

Internal Radiation:

These are radiations from radioactive materials which are present in the human body. These come from natural radioactive sources such as Carbon-14 in the air we breathe. Fruits and crops take in radioactive materials from the soil as well as Carbon-14 from the air.

Artificial sources of background radiations:

These are mainly from human activities. They include:

Nuclear power stations:

Major incidents from nuclear power stations have released radiations into the environment. Nuclear waste from power station also accounts for a proportion of artificial background radiation.

Nuclear weapons:

Nuclear weapon testing resulted in an increase of radiation in the environment because of **radioactive fallout** from nuclear weapons testing.

Medical sources:

Humans are exposed to radiations by medical procedures such as x-rays and radiotherapy. Nearly all artificial background radiation comes from medical procedures such as receiving X-rays for X-ray photographs.

Detecting the radiation:

The following can be used to detect radiations;

Photographic film:

Photographic film goes darker when it absorbs radiations. The more radiation the film absorbs, the darker it becomes. People, who work with radiation, wear film badges which are checked regularly to monitor the levels of radiation absorbed.

Geiger-Muller tube and Cloud Chamber:

The Geiger-Muller tube or cloud chamber detects radiation and each time it absorbs radiation, it transmits an electrical pulse to a counting machine. This makes a clicking sound or displays the count rate. The greater the frequency of clicks, the higher the count rate and the more radiation the Geiger-Muller tube or cloud chamber is absorbing.

NUCLEAR REACTIONS:

This is a process in which energy is produced. A nuclear reaction takes place in a nuclear reactor. There are two types of nuclear reactions and these are

- Nuclear fusion.
- Nuclear fission.

Nuclear fusion:

This is a process by which two light nuclei combine to form a heavy nucleus with release of energy.

It takes place at the sun, stars and in the hydrogen bomb.

The process results into three products i.e. one heavy atom, neutron and energy.

Example:

Two Deuterium nuclei (heavy hydrogen) combine to form Helium -3 and a neutron with release of energy



Conditions for nuclear fusion to occur:

- It occurs at very high temperature
- The light nuclei should be moving at a very high speed

Nuclear fission:

This is the splitting of a heavy nucleus into two lighter nuclei with release of energy.

This process is started by bombardment of a heavy nucleus with a slow-moving neutron.

The four products of the process are two light atom and more neutrons which can make the process continue and energy.

Example:

Splitting of uranium-236 ${}^{236}_{92}\text{U}$ to form Barium (Ba) and Krypton (Kr) with release of energy.

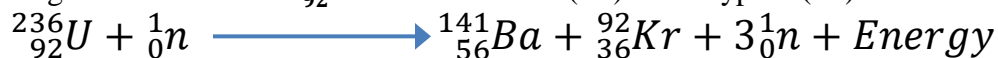

Conditions for nuclear fission:

- It occurs at very low temperature.
- It requires a slow moving neutron.
- Presence of a heavy nucleus.

Uses of nuclear fusion and nuclear fission

- Used to produce hydrogen.
- Nuclear fusion is used to make hydrogen bombs.
- Used to produce electricity.
- Used to produce heat energy on large scale.
- Nuclear fission is used to make atomic bombs.

Differences between nuclear fusion and nuclear fission

Nuclear fission	Nuclear fusion
<ul style="list-style-type: none"> ▪ Is the splitting of a heavy nucleus into two lighter nuclei. ▪ Requires a low temperature. ▪ Requires neutrons for bombardment. ▪ Results into four products. ▪ Energy released is high. 	<ul style="list-style-type: none"> ▪ Is the combining of two lighter nuclei to form a heavy nucleus. ▪ Requires a high temperature. ▪ Neutrons are not required. ▪ Results into three products. ▪ Energy released is low.

Example:

Find the values of x and y in the above nuclear fission reaction.

$$\begin{array}{l|l} 236 = 144 + y + 2 & 92 = x + 36 + 0 \\ 236 = 146 + y & 92 = x + 36 \\ \mathbf{y = 90} & \mathbf{x = 56} \end{array}$$

HALF LIFE:

This is the time taken for a radioactive element to decay to half its original mass.

Half-life is measured in seconds, minutes, hours, days, weeks, months and years.

Half-life is not affected by physical factors like temperature and pressure and half-life is different for different radioactive nuclides.

If M_o is the original mass of a radioactive element and M_T is the mass of a radioactive element at any time, t , then

$$\frac{M_o}{M_T} = 2^{\frac{t}{T_{1/2}}}$$

Where $T_{1/2}$ is the half-life of a radioactive element.

Examples:

1. If a radioactive element of mass 32g decays to 2g in 96 days. Calculate the half-life.

Method 1:

$$32g \xrightarrow{T_{1/2}} 16g \xrightarrow{T_{1/2}} 8g \xrightarrow{T_{1/2}} 4g \xrightarrow{T_{1/2}} 2g$$

$$4T_{1/2} = 96$$

$$T_{1/2} = \frac{96}{4}$$

$$T_{1/2} = 24 \text{ days}$$

Method 2:

$M_o = 32g,$	$\frac{32}{2} = 2^{\frac{96}{T_{1/2}}}$
$M_T = 2g,$	$16 = 2^{\frac{96}{T_{1/2}}}$
$t = 96\text{days},$	$2^4 = 2^{\frac{96}{T_{1/2}}}$
$T_{1/2} = ?$	$4 = \frac{96}{T_{1/2}}$
$\frac{M_o}{M_T} = 2^{\frac{t}{T_{1/2}}}$	$T_{1/2} = 24 \text{ days}$

2. A radioactive element of mass 9.6g has a mass of 0.15g after 24hours.

Method 1:

$$9.6g \xrightarrow{T_{1/2}} 4.8g \xrightarrow{T_{1/2}} 2.4g \xrightarrow{T_{1/2}} 1.2g \xrightarrow{T_{1/2}} 0.6g \xrightarrow{T_{1/2}} 0.3g \xrightarrow{T_{1/2}} 0.15g$$

$$6T_{1/2} = 24$$

$$T_{1/2} = \frac{24}{6}$$

$$T_{1/2} = 4 \text{ hours}$$

Method 2:

$M_o = 9.6g,$	$\frac{9.6}{0.15} = 2^{\frac{24}{T_{1/2}}}$
$M_T = 0.15g,$	$64 = 2^{\frac{24}{T_{1/2}}}$
$t = 24\text{hours},$	$2^6 = 2^{\frac{24}{T_{1/2}}}$
$T_{1/2} = ?$	$6 = \frac{24}{T_{1/2}}$
$\frac{M_o}{M_T} = 2^{\frac{t}{T_{1/2}}}$	$T_{1/2} = 4 \text{ hours}$

3. A radioactive element of mass $12g$ has a half-life of 7 years. Find the time taken for the element to decay to $0.75g$.

Method 1:

$$12g \xrightarrow{T_{1/2}} 6g \xrightarrow{T_{1/2}} 3g \xrightarrow{T_{1/2}} 1.5g \xrightarrow{T_{1/2}} 0.75g$$

$$\begin{aligned} 4T_{1/2} &= t \\ 4 \times 7 &= t \\ t &= 28 \text{ years} \end{aligned}$$

Method 2:

$\begin{aligned} M_o &= 12g, \\ M_T &= 0.75g, \\ t &=?, \\ T_{1/2} &= 7 \text{ years} \\ \frac{M_o}{M_T} &= 2^{\frac{t}{T_{1/2}}} \end{aligned}$	$\begin{aligned} \frac{12}{0.75} &= 2^{\frac{t}{7}} \\ 16 &= 2^{\frac{t}{7}} \\ 2^4 &= 2^{\frac{t}{7}} \\ 4 &= \frac{t}{7} \\ t &= 28 \text{ years} \end{aligned}$
--	--

4. A certain mass of a radioactive material contains 2.7×10^{24} atoms, how many atoms decayed after 3200 years if the half-life of material is 1600 years.

$$M_o = 2.7 \times 10^{24}, T_{1/2} = 1600 \text{ years}, t = 3200 \text{ years}$$

Mass decayed = original mass – mass remaining

$$M_D = M_o - M_T$$

$$\begin{aligned} \frac{M_o}{M_T} &= 2^{\frac{t}{T_{1/2}}} \\ \frac{2.7 \times 10^{24}}{M_T} &= 2^{\frac{3200}{1600}} \\ \frac{2.7 \times 10^{24}}{M_T} &= 2^2 \\ \frac{2.7 \times 10^{24}}{M_T} &= 4M_T \\ \frac{2.7 \times 10^{24}}{4} &= M_T \\ M_T &= 6.75 \times 10^{23} g \end{aligned}$$

$$\begin{aligned} M_D &= 2.7 \times 10^{24} - 6.75 \times 10^{23} \\ &= 2.025 \times 10^{24} \\ \text{Mass decayed} &= 2.025 \times 10^{24} g \end{aligned}$$

Half-life from the graph:

- The graph of amount of an element, N against time, t is plotted.
- Draw a horizontal line from half of the original amount to meet the curve.
- Draw a vertical line from the point on the curve to meet the time axis.
- Read the half-life from where the vertical line meets the time axis.

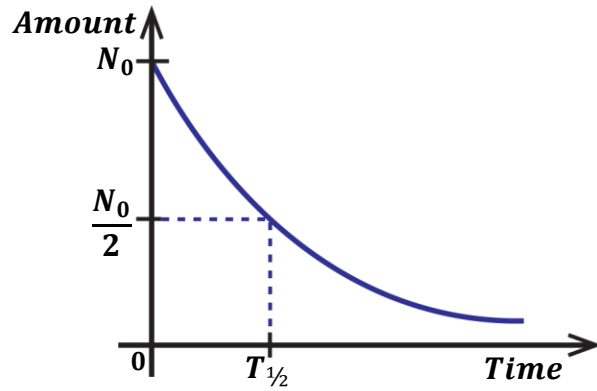

Example:

The table below shows results obtained in an experiment to determine the half-life of a radioactive substance.

Count rate	250	140	76	38	25
Time (min.)	0	5	10	15	20

Draw a graph of count rate against time and use it to determine the half-life of the radioactive substance.

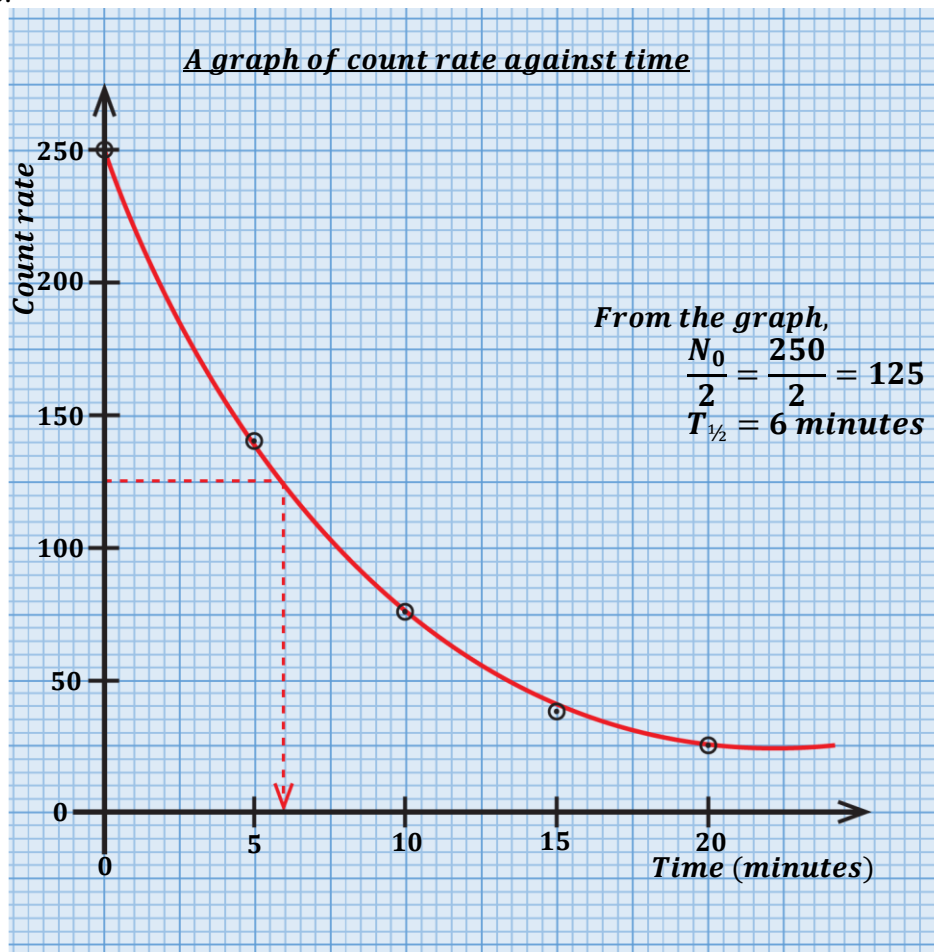

Exercise:

The following values obtained from the readings of a rate meter from a radioactive isotope of iodine.

Time (min)	0	5	10	15	20
Count rate (min^{-1})	295	158	86	47	25

Plot a suitable graph and find the half-life of the radioactive iodine.

EXERCISE:

- Define the following terms
 - Atomic number
 - Mass number
 - State the composition of elements ${}^{222}_{86}\text{X}$ and ${}^{224}_{86}\text{Y}$
 - What is meant by the term radioactivity
 - Name the radiations emitted by radioactive materials
 - State the properties of the radiations named in (b) (i) above
 - What dangers may arise when one is exposed to radioactive materials?
- What is a radioactive nuclide
 - State the changes that take place in the nucleus of an atom if it emits
 - Alpha particle
 - Beta particle
 - Gamma ray
 - Explain the origin of beta particles and gamma rays.
 - Explain why
 - Alpha particles are more ionizing than beta particles
 - Alpha particles have a short range in air than beta particles
 - Beta particles are deflected more than alpha particles by the same magnetic field
- The nuclide ${}^{226}_{86}\text{X}$ decays to nuclide Y by emission of alpha particle.
 - Write the equation for the decay.
 - State the atomic number and mass number of Y.

Ans: [Mass Number = 222, Atomic Number = 87]
 - The nuclide ${}^{24}_{11}\text{A}$ decays to nuclide P by emission of beta particle.
 - Write the equation for the decay.
 - State the atomic number and mass number of P.

Ans: [Mass Number = 24, Atomic Number = 12]
 - The nuclide ${}^{214}_{82}\text{X}$ decays to nuclide M by emission of beta particle and gamma ray.
 - Write the equation for the decay.
 - State the atomic number and mass number of M.

Ans: [Mass Number = 214, Atomic Number = 83]
 - The nuclide ${}^{226}_{88}\text{Ra}$ decays to nuclide Y by emission of two alpha particles and one beta particle.
 - Write the equation for the decay.
 - State the atomic number and mass number of Y.

4. Given that R and H decay as shown below



Find m , n and identify particle D

Ans: [$m = 2, n = 3$]

5. Given that Ra decays to Y according to the equation



Find the values of A and Z.

Ans: [$A = 218, Z = 85$]

6. a) Define the term half-life.
 b) A radioactive sample of mass 60g has half-life of 8 minutes. Determine how much of it remains after 40 minutes.

Ans: [**1.875g**]

- c) An element X of mass 64g decays to 4g in 96 days. Calculate

(i) The half-life of X.

(ii) The mass that decays in 120 days.

(iii) How long does it take for $\frac{3}{4}$ of the sample to decay?

Ans: i) [**24 days**] ii) [**2g**] iii) [**48 days**]

7. a) Define the terms

(i) Nuclear fusion

(ii) Nuclear fission

- b) i) State the conditions necessary for each to take place

ii) Give two examples where each takes place



Find the values of x and y



Find the atomic number and mass number of Q

Ans: i) [$x = 141, y = 36$] ii) [**Mass Number = 4, Atomic Number = 2**]

8. a) What is background radiation.
 b) i) Describe the structure and action of Geiger-Muller tube.
 ii) Describe the structure and action of diffusion cloud chamber.
 c) Draw diagrams to show tracks of each of the radioactive radiations appear in the Geiger-Muller tube.

THERMIONIC EMISSION:

This is the process by which electrons are emitted from a hot metal surface.

Production of electrons

Electrons can be produced by;

- Thermionic emission
- Photo electric emission

Kinetic theory explanation of thermionic emission:

When a metal surface is heated to a certain temperature, the free electrons at the surface gain kinetic energy and they overcome the forces of attraction by the nucleus hence escaping from the metal surface.

Applications of thermionic emission:

Thermionic emission can be applied in the following devices;

- Diode valves.
- Cathode ray tube.
- Cathode ray oscilloscope.
- X-ray tube.

PHOTO ELECTRIC EMISSION:

This is the process by which electrons are emitted from the metal surface when exposed to electromagnetic waves of sufficient frequency.

Photo electric emission occurs in phototubes [photoelectric cells].

The electrons emitted are referred to as photoelectrons and the electromagnetic waves used are called ultra violet radiations.

Photoelectric cell:

- Photoelectric cell is composed of the cathode coated with a photo-sensitive material and the anode enclosed in a vacuum tube.
- The glass tube is evacuated in order to avoid collision of cathode rays with air molecules which may lead to low current flowing due to loss in kinetic energy of cathode rays.

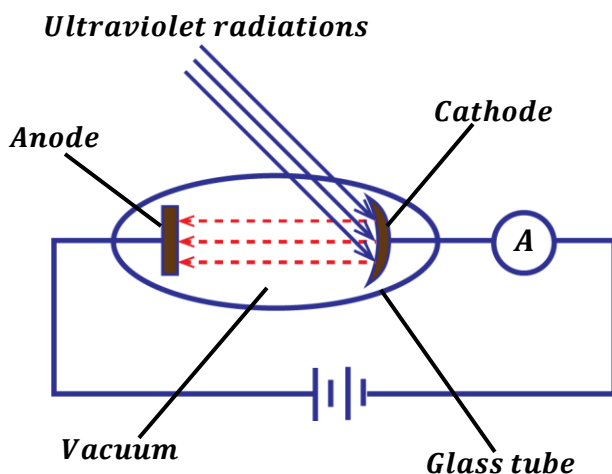

Mechanism of a photoelectric cell:

- Electromagnetic radiation is directed onto the cathode and supplies sufficient energy that causes the liberation of electrons.
- The electrons emitted are then attracted to the anode and the flow of electrons generates a current around the circuit and the ammeter deflects.
- The amount of the current produced is proportional to the intensity of the radiation.
- The stream of electrons flowing from the cathode to the anode is referred to as cathode rays.

NOTE:

If a gas is introduced into the tube, the current decreases slowly because the gas particles collide with the electrons, hence reducing the number of electrons reaching the anode.

EXPERIMENT TO DEMONSTRATE PHOTOELECTRIC EFFECT

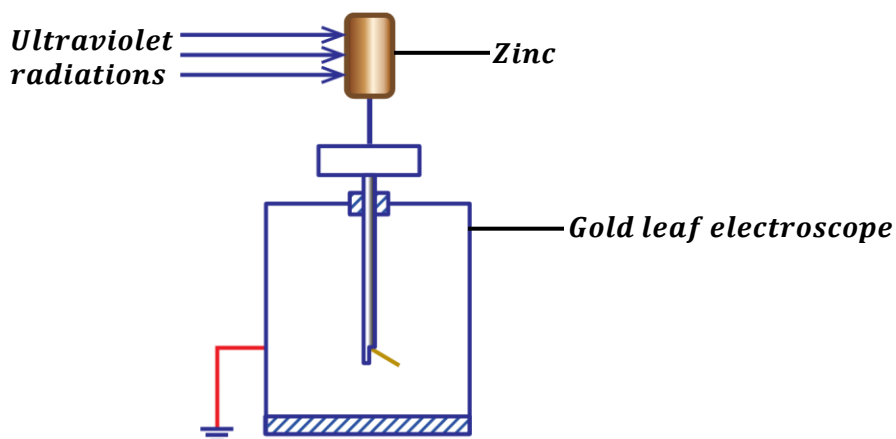

When Ultra violet light is incident on a clean zinc plate placed on the cap of a gold leaf electroscope:

- If the **electroscope is negatively charged**, the leaf divergence slowly decreases indicating that it is losing charge. This is because since radiations fall on a zinc plate, electrons are emitted from leaving it with no electrons. So this makes the electrons to move from the leaf and gold plate to the zinc to replace the lost electrons.
- If the **electroscope is positively charged**, there is no change in divergence of the leaf. This is because the emitted electrons after ionization in air are attracted back by the positively charged zinc hence no loss of charge.

Conclusion:

The Zinc plate emits photoelectrons when ultra violet radiation falls on it.

Note: Radio waves can't be used because they don't have sufficient energy to emit electrons from zinc.

Applications of photoelectric effect:

Photoelectric effect is applied in:

- 1) Burglar alarms.
- 2) Automatic lighting systems
- 3) In solar calculators.
- 4) Television cameras.
- 5) Automatic door system.
- 6) Sound track on a film.

CATHODE RAYS:

These are streams of fast-moving electrons.

They are produced from the cathode by thermionic emission. Cathode rays carry energy since they possess speed.

Production of cathode rays:

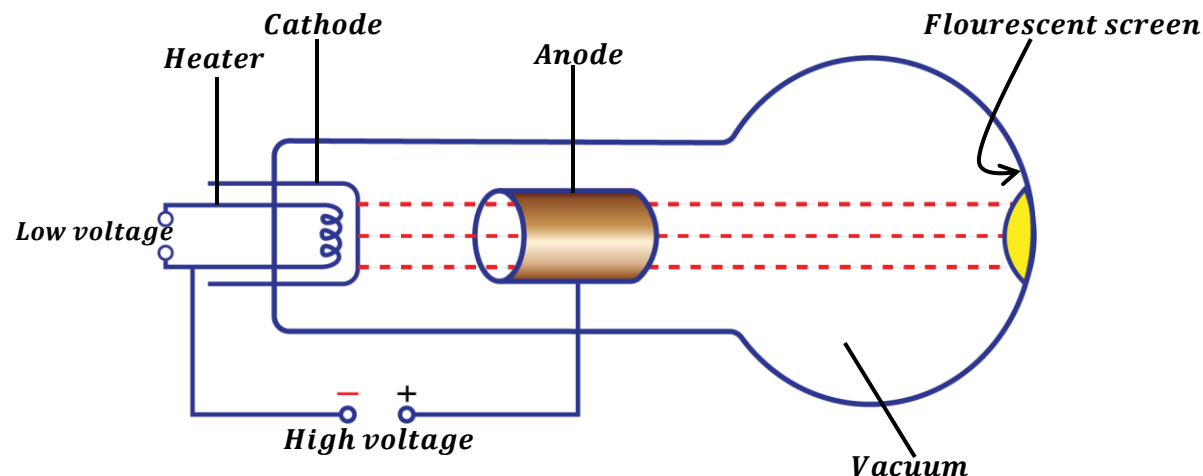

- The cathode is heated by a low voltage applied across the heater.
- The cathode then emits electrons by thermionic emission.
- The emitted electrons are then accelerated by a high voltage applied between the heater and the anode so that they move with a very high speed hence forming cathode rays.
- Some of the electrons (cathode rays) pass through the anode and a parallel beam of electrons is obtained which is received as spot on the fluorescent screen.

Note: The tube is evacuated to prevent cathode rays from colliding with air particles hence free movement of cathode rays.

Properties of cathode rays:

- They travel in straight lines.
- They are negatively charged since they are electrons.
- They produce X-rays when stopped by a heavy metal.
- They are deflected by magnetic fields i.e. towards the north pole.
- They are deflected by electric fields i.e. towards positive plate.
- They possess momentum and kinetic energy.
- They cause fluorescence when they strike matter i.e. they cause other materials to give off light.
- They ionize air and gas molecules.

Experiment to show that cathode rays travel in straight line (Thermionic tube).

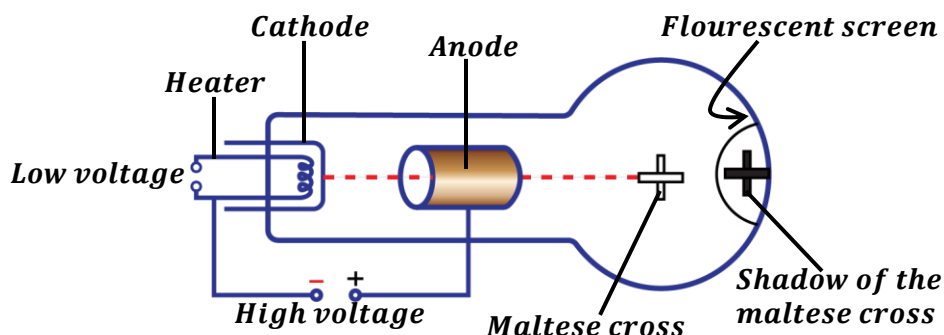

When cathode rays are directed towards the Maltese cross in a cathode ray tube. A shadow of the cross is formed on the fluorescent screen. The formation of the shadow verifies that cathode rays travel in a straight line.

Applications of cathode rays:

Cathode rays are applied in the following devices;

- Cathode ray oscilloscope.
- X – ray tube.
- Diode.

Cathode Ray Oscilloscope [C.R.O]:

It is an instrument used to study current and voltage wave forms.

It has three main parts and these are

- Electron gun.
- Deflecting system.
- Fluorescent screen.

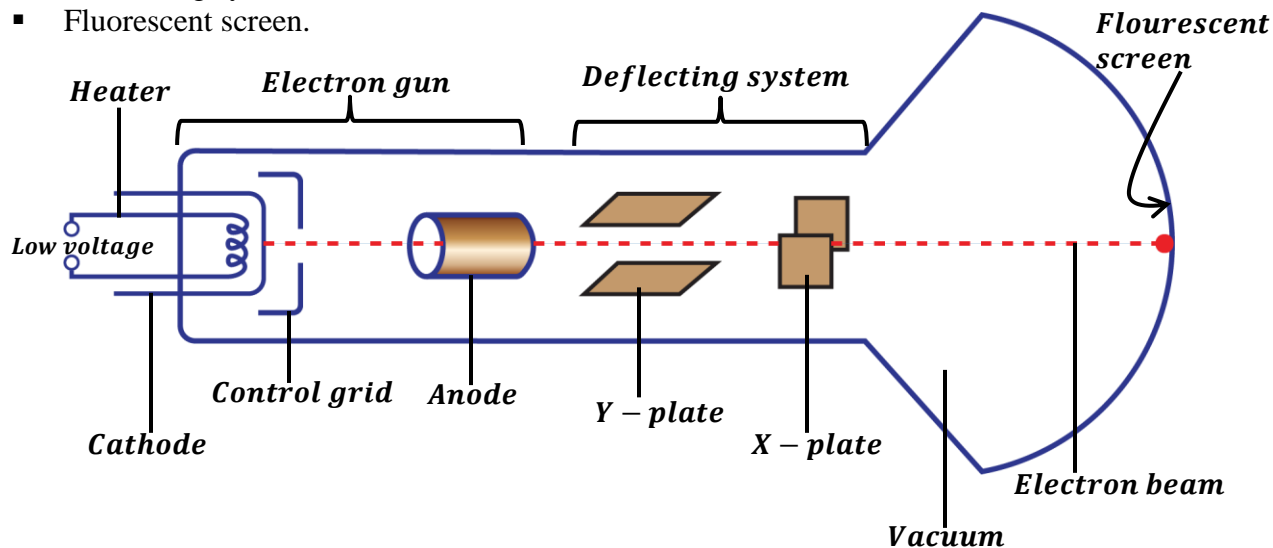

Functions of the parts:

(a) **Electron gun:**

It consists of a heater, cathode, grid and Anode.

- (i) The heater: This heats the cathode electrically.
- (ii) The cathode: It emits electrons by thermionic emission i.e. when heated electrically by the heater.
- (iii) The control grid: It controls the brightness of the spot on the screen by controlling the number of electrons reaching the anode and screen.
- (iv) The anode: It is used to accelerate the electrons produced by the cathode.

(b) **Deflecting system:**

It consists of the X – plates and Y – plates.

The Y – plates deflect the beam of electrons vertically.

The X – plates deflect the beam of electrons horizontally.

(c) **Fluorescent screen:**

This is where the bright spot of electrons is formed.

NOTE:

- The inner walls of the cathode ray oscilloscope are coated with graphite to trap stray electrons emitted from the screen.
- The cathode ray oscilloscope is evacuated to minimize loss of energy of electrons due to collision with air molecules.

(d) Time base:





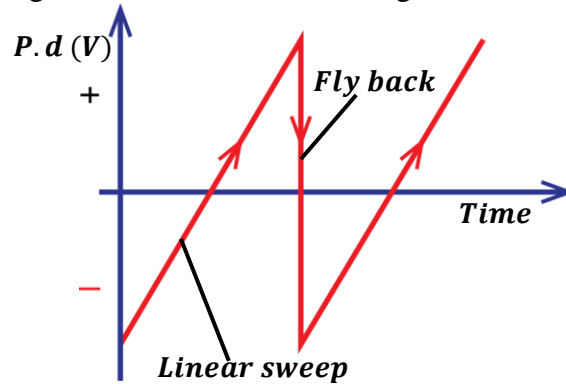

This is a special circuit that generates p.d which rises steadily to a certain value and falls rapidly to zero. It is connected across the X-plates.

The time base is used to generate a saw-toothed voltage.

Note:

The time base is connected to the X – plates and causes the spot to move from left to right which is called **linear sweep** and the spot returns to the left before it starts the next sweep which is called **fly back**.

Wave forms on C.R.O screen.

(i) No A.C voltage on the Y-plates and time base on 	(ii) A.C voltage on the Y-plates and time base off 
(iii) A.C voltage on the Y-plates and time base on 	(iv) D.C voltage on the Y-plates only and time base off 
(v) No D.C voltage on the Y-plates and time base on 	(vi) D.C voltage on the Y-plates and time base on 
(vii) No potential difference is applied to the Y-plates and time base off 	

USES OF C.R.O:

- It is used to measure potential difference.
- It is used to study wave forms.
- It is used to measure the frequency of the wave.
- It is used to measure the wave length of the wave.
- It is used to measure phase difference between two voltages.
- It is used as a timing device.
- It is used to measure the peak value of alternating and direct current.
- It is used to display pictures in TV sets.

Advantages of C.R.O over ordinary ammeter or voltmeter:

- It has infinite resistance therefore draws no current from the circuit.
- It is not affected by high voltages/currents.
- It measures both alternating and direct voltages.
- It is very accurate.
- It has no coil to burn out.
- It responds very fast.

Disadvantages of C.R.O over ordinary ammeter or voltmeter:

- It is not portable.
- It requires skilled personnel.
- It is expensive.
- It takes a lot of time to measure voltages.
- It does not give direct readings.

MEASURING VOLTAGE ON A C.R.O SCREEN

Voltage = [voltage gain/cm] × [amplitude(vertical deflection)]

$$V = V_g d$$

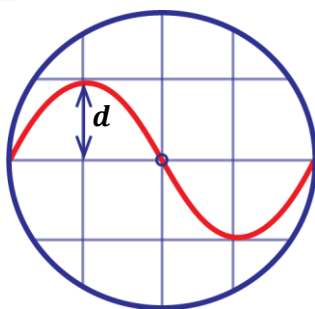

Also, root mean square voltage is given by;

$$V_{r.m.s} = \frac{V}{\sqrt{2}}$$

Also, period;

$$T = [\text{time base setting/frequency gain}] \times [\text{wavelength length for cycle}]$$

Examples:

1. A cathode oscilloscope CRO with time base switched on is connected across a power supply. The wave form shown in figure below is obtained. Length between each line is 1cm .

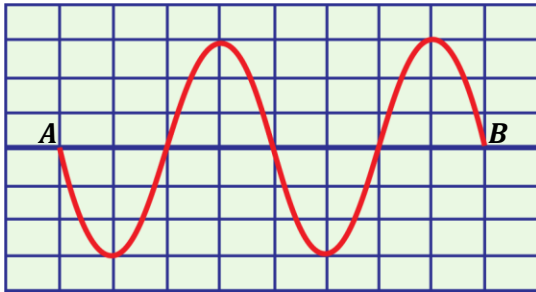

- Identify the type of voltage generated by the power supply.
- Find the maximum voltage (amplitude of voltage) generated if the voltage gain is 5Vcm^{-1} .
- Calculate the frequency of the power source, if the time base setting on the C.R.O is $5 \times 10^{-3}\text{scm}^{-1}$.

Solutions:

(a) *Alternating current voltage*

(b)

From the graph, amplitude = 3cm

$V = \text{voltage gain} \times \text{amplitude}$

$$V = 5 \times 3$$

$$V = 15\text{V}$$

(c)

Period, $T = \text{Time base} \times \text{wavelength}$
setting

wavelength = 4cm

time base setting = $5 \times 10^{-3}\text{scm}^{-1}$

$$T = 5 \times 10^{-3} \times 4$$

$$T = 0.02\text{s}$$

$$f = \frac{1}{T} \Rightarrow f = \frac{1}{0.02}$$

$$f = 50\text{Hz}$$

2. A CRO with the time base switched on is connected across a power supply. The wave form shown below is obtained. Distance between each line is 1cm .

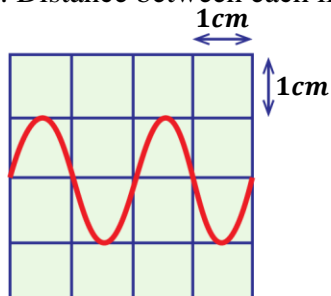

- Identify the type of voltage generated by the power supply.

An alternating current voltage

- Find the maximum value of the voltage generated if the voltage gain is 10Vcm^{-1} .

Amplitude or vertical deflection, $d = 1\text{cm}$

$V_{\text{max}} = \text{Voltage gain/cm} \times \text{amplitude}$

$$V = V_g d$$

$$V = 10\text{Vcm}^{-1} \times 1\text{cm} = 10\text{V}$$

- c) Calculate the frequency of the power source if the time base setting on the CRO is $10.0 \times 10^{-3} \text{scm}^{-1}$.

Period, $T = \text{time base setting} \times \text{wavelength}$

$$T = 10.0 \times 10^{-3} \times 1.5$$

$$T = 0.015\text{s}$$

$$f = \frac{1}{T}, \quad f = \frac{1}{0.015}$$

$$f = 66.7\text{Hz}$$

X-RAYS:

These are electromagnetic waves of short wavelength which are produced when cathode rays are stopped by a metal surface.

Production of X-Rays (X-Ray Tube):

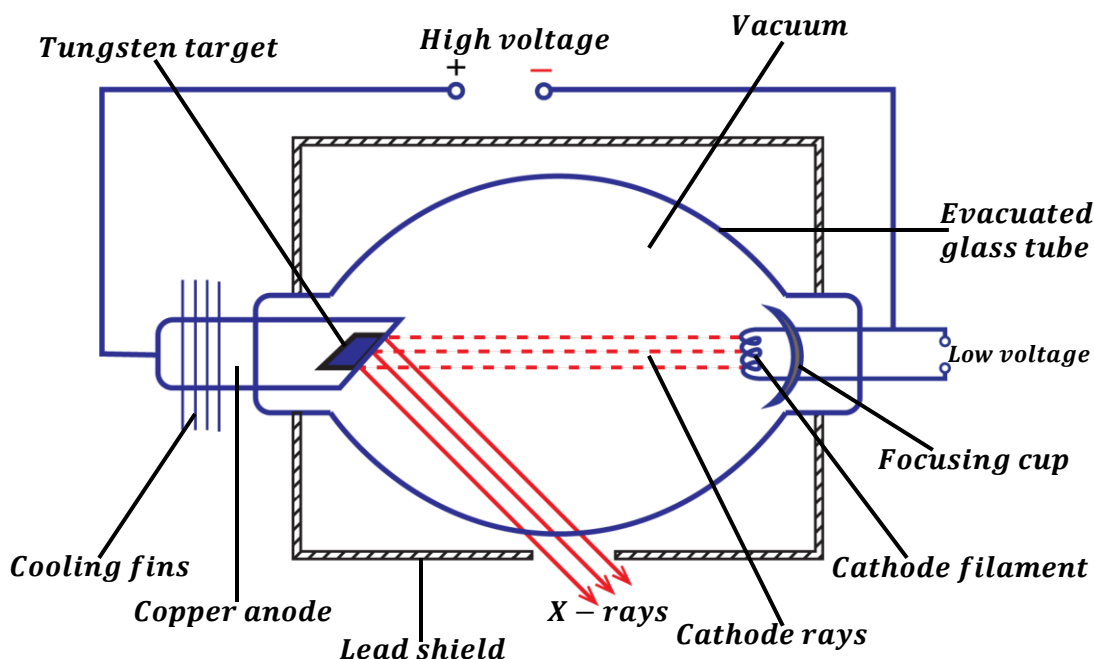

Mode of operation:

- The cathode is heated by a low voltage and electrons are emitted from it by thermionic emission.
- The electrons are accelerated to the anode by the high voltage supply connected across the cathode and anode.
- And on reaching the metal target, 99% of the kinetic energy of electrons is converted into heat and 1% of kinetic energy of electrons is converted into X-rays.
- The heat generated at the target is cooled down by means of cooling fins and then conducted.
- The X – ray tube is evacuated to prevent cathode rays from colliding with air molecules hence allowing free movement of electrons in the tube.

NOTE:

- ✓ The tungsten is used because it has a high melting point that can withstand the heat generated when electrons hit the target.
- ✓ The curvature of the cathode helps to focus emitted electrons onto the anode.
- ✓ The cooling fins are painted black to radiate the heat quickly.
- ✓ The lead shield absorbs stray X-rays

In the X – ray tube the following energy changes take place;

Electrical energy → Heat energy → Kinetic energy → Electromagnetic energy

PROPERTIES OF X – RAYS:

- They carry no charge.
- They are not deflected by both magnetic and electric fields.
- They readily penetrate matter. Penetration is least with materials of high density.
- They cause ionization of gases.
- They affect photographic films.
- They travel in a straight line.
- They travel at a speed of light.
- They undergo reflection, refraction and diffraction by atoms.
- They are electromagnetic waves of very short wave length.
- They cause fluorescence when they strike matter.
- They can produce photoelectric emission

Intensity of X- Rays (Quantity):

Intensity is the strength or power of X-rays.

The intensity of X-rays in an X-ray tube is proportional to the number of electrons reaching the target. The number of electrons produced is determined by the filament current. Therefore, the higher the filament current the higher the intensity of the X-rays since more electrons are emitted with high filament current.

Question: Describe how the intensity of X-rays can be improved/increased.

This is done by increasing the filament current which increase the temperature of the filament cathode thus increasing the number of electrons emitted thermionically. Hence the number of electrons hitting the target will increase.

Penetration power of X-Rays (Quality):

Penetration power is the ability of X-rays to enter matter.

The penetration power of X-rays depends on the kinetic energy of electrons reaching the target. The penetration power of X-rays is determined by the high potential difference across the X-ray tube.

The higher the accelerating voltage the faster the electrons produced and the greater the kinetic energy of electrons hence the higher the penetration power of X-rays produced.

Question: Describe how the penetrating power of X-rays is increased.

This is done by increasing the accelerating voltage between the anode and cathode which makes electrons to move with a faster speed hence increasing the kinetic energy. This increases the penetrating power of X-rays.

TYPES OF X-RAYS

There are two types namely;

- Hard X-rays
- Soft X-rays.

SOFT X-RAYS:

These are X-rays of low penetrating power.

Properties of soft X-rays:

- They produced by low accelerating voltages.
- They have a low penetration power.
- They have low kinetic energy.
- They have a long wave length.
- They have a low frequency

HARD X-RAYS:

These are X-rays of high penetrating power.

Properties of hard X-rays:

- They produced by high accelerating voltages
- They have a high penetration power.
- They have high kinetic energy.
- They have a short wave length.

Differences between soft X-rays and hard X-rays

HARD X-RAYS	SOFT X-RAYS
<ul style="list-style-type: none"> • Produced by a high voltage. • They have a shorter wavelength. • They are more penetrative. • They have a high frequency. • They have high kinetic energy. 	<ul style="list-style-type: none"> • Produced by low voltage. • They have a longer wavelength. • They are less penetrative. • They have a low frequency. • They have low kinetic energy.

SIMILARITIES BETWEEN X-RAYS AND GAMMA RAYS

- They are both electromagnetic waves.
- They both pass through a vacuum.
- Both are not deflected in both electric and magnetic fields.
- They both have no charge.
- They both travel with a speed of light.
- They are both transverse waves.

USES OF X-RAYS:

Medical uses:

- They are used to investigate the broken bones in X – ray photography.
- They are used to treat cancer cells.
- They used to detect the complicated organs of the body.
- They are used to detect tuberculosis of the lungs.

- They are used to diagnose stomach ulcers.

How x-rays are used to locate broken parts of a bone.

- ❖ *When X-rays are passed through the body onto the photographic plate or film, The bones which are composed of a much denser material than the flesh absorb most of the X-rays and appear white on the photographic plate or film. The flesh which is composed of less dense material allows most of the X-rays to pass through it hence darkening the photographic film or plate. These shadows are studied in order to locate the broken part.*

Industrial uses:

- They are used to detect cracks in metal castings and welded joints.
- They are used to study the structure of crystals [crystallography].
- They are used to detect faults in motor tyres.
- They are used to detect defects in paints.

Dangers of X-rays:

- They destroy living cells in the body.
- They damage blood cells and eye sight.
- They cause genetic changes [mutation].
- They skin burns due to their greater penetration power.
- They cause cancer after excessive exposure.

Safety precautions taken when using X-rays:

- Avoid unnecessary exposure to X-rays.
- The X-ray apparatus should be shielded using thick lead.
- The person should wear protective clothing made of thick lead.
- Keep large distance between X-ray source and people.
- Soft X-rays should always be used on human tissues

THE DIODE:

This is an electrical device that conducts electricity in one direction only.

There are two types of diodes and these are

- Semi-conductor diode.
- Vacuum diode.

Thermionic diode (vacuum diode):

This is a device used to change alternating current to direct current.

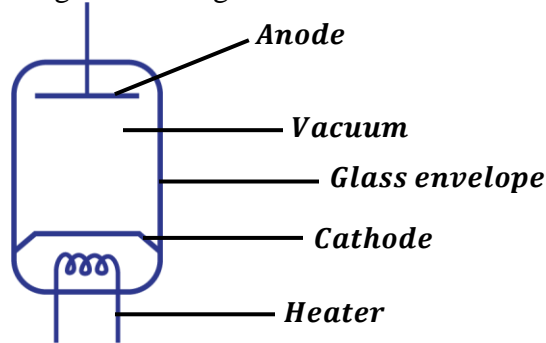

It consists of the following;

- The heater which heats the cathode electrically.
- The cathode which emits electrons thermionically.
- The anode which accelerates electrons emitted from the heated cathode.
- Evacuated glass envelope helps to prevent electrons from colliding with air molecules.

RECTIFICATION:

This is a process of changing alternating current to direct current.

This is done by use of a diode (rectifier).



The arrow head in the diode or rectifier shows the direction of flow of current.

There are two types of rectification and these are;

- Half wave rectification
- Full wave rectification

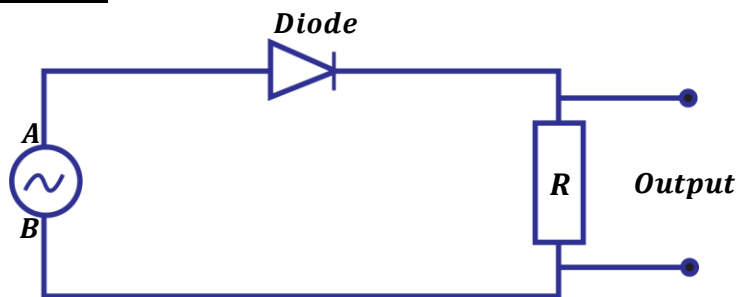
Half wave rectification:

- During the first half of the cycle when A is positive and B is negative, the diode conducts current and it flows through the resistor R.
- During the next half cycle when B is positive and A is negative, the diode doesn't conduct current to flow through the resistor R.
- Hence current flows through R during only one half of the cycle when A is positive with respect to B.

The graph of current/voltage against time for half wave is as shown below.

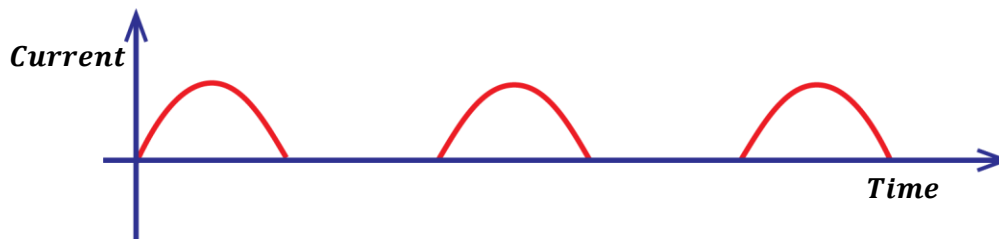

Full wave rectification:

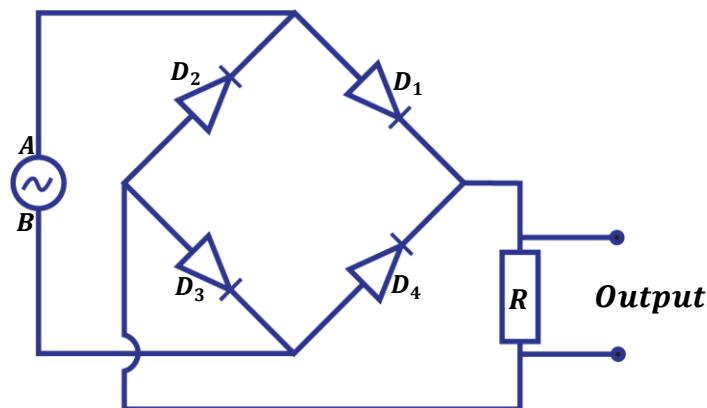

- During the first half cycle when A is positive and B is negative, diodes D_1 and D_3 conduct current and it flows through the resistor R. Diode D_3 takes back current to the source. Diodes D_2 and D_4 do not conduct current.
- During the next half cycle when B is positive and A is negative, diodes D_2 and D_4 conduct current and it flows through the resistor R. Diode D_4 takes back current to the source. Diodes D_1 and D_3 do not conduct current.
- Hence current flows through R during both cycles and therefore both cycles are rectified giving a full wave rectification.

The graph of current/voltage against time for full wave rectification is as shown below.

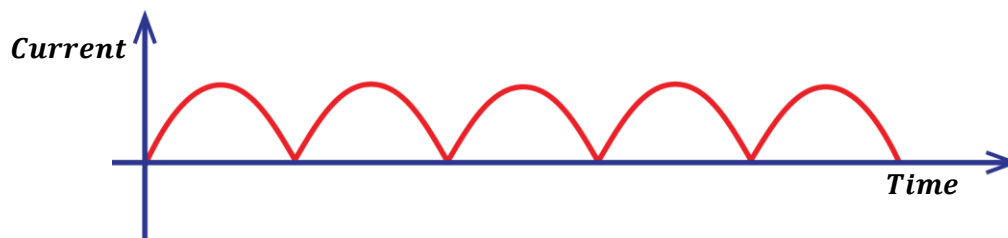

EXERCISE:

1. a) What is a diode?
 - (i) Draw a graph of current against p.d across the diode and explain the features of your graph.
 - (ii) What is rectification?

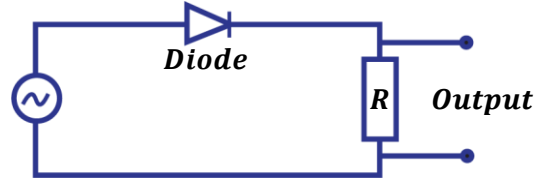

- b) The diagram above shows a diode in a circuit that can be used to change a.c to d.c. Draw a graph for the variation of voltage against time.
- c) What is meant by the term photo electric emission?
- d) Give applications of photo cells
2. a) What are cathode rays
- b) Give the properties of cathode rays
- c) Draw a well labeled diagram of cathode ray oscilloscope (C.R.O) and give the function of each part.
3. a) i) Draw a well labeled diagram of an X-ray tube and describe how X-rays are produced.
- b) State the effect on X-rays produce when
 - i) The filament current is increased
 - ii) The anode is made more positive
- c) Explain how the intensity and penetrating power of X-rays in an X-ray tube may be varied.
4. a) i) State and explain what happens when X-rays are passed above the cap of a positively charged gold leaf electroscope.
- b) Would your observation and explanation in (a) (i) above be different if the gold leaf electroscope is negatively charged.
- c) Briefly explain how X-rays may be used to locate the broken part of a bone.
- d) State and explain what happens when X-rays are directed into a metal block like that of lead.

EXAMINATION QUESTIONS:

1. a) What is meant by the following;
 (i) Radioactivity
 (ii) Half-life
- b) The following figures were obtained from the reading of a rate metre for the alpha particle emission from Thoron – 220.

Time(s)	0	20	40	60	80	100	120	140
Average Counts	96	72	55	45	36	26	20	15

Plot a suitable graph from the readings and obtain the half-life of Thoron – 220

Ans: [52 seconds]

- c) i) Distinguish between soft x-rays and hard x-rays
 ii) Mention two uses of x-rays and briefly describe how they are applied.
2. a) Define the following terms
 i) Atomic number
 ii) Mass number
- b) When lithium is bombarded by Neutrons, a nuclear reaction occurs which is represented by the following reaction.



Complete the equation and name P

- c) i) Describe the application of radioactivity in determining the age of foils.
 (ii) Give two harmful effects of radioactivity.
- d) The half-life of Uranium is 24 days. Calculate the mass of Uranium which remains after 120 days if the initial mass is 64g

Ans: [2g]

- e) State three differences between alpha particles and gamma rays
3. a) Draw a labeled diagram of x-ray tube.
 b) i) Using the diagram in (a) above, explain how x-rays are produced
 ii) What adjustments will you make while using the x-ray tube to obtain hard x-rays instead of soft x-rays?
 c) i) Explain the use of a cooling system in an x-ray tube
 ii) What special property has a metal target in the x-ray tube and why
 iii) Why are x-rays used in study of crystals?
 iv) If x-rays have wave lengths ranging from 10^{-8}m and 10^{-10}m . What is the frequency of the hardest x-rays that can be obtained?

Ans: [3 × 10¹⁸ Hz]

4. a) Give two methods of producing electrons from the metal surface.
 b) State the effect of each of the following on a fine beam of electrons
 i) Electric field
 ii) Magnetic field
 c) i) Explain briefly how x-rays are produced (diagram not necessary)
 ii) Distinguish between soft x-rays and hard x-rays
 iii) What precaution should be taken in order to minimize x-rays health hazards

5. a) Define radioactivity
 b) i) Name any two particles emitted by radioactive nuclides
 ii) State the three differences between the two particles named in (b) (i) above
 c) The table below gives the count produced by a radioactive isotope at different times during an experiment

Time (hour)	0.0	1.0	1.8	2.5	3.0	3.8	4.5	5.5
Counts rate (min^{-1})	1816	1376	1096	896	776	616	516	416

- i) Given that a back-ground count of 16 counts per minute was recorded throughout the experiment, plot a suitable graph and use it to determine the half-life of the isotope
 ii) What is the count rate after 9.6 hours?
Ans: i) [2.6 hours] ii) [125 per minute]
6. The diagram in the figure below shows the main parts of a cathode ray oscilloscope (C.R.O)

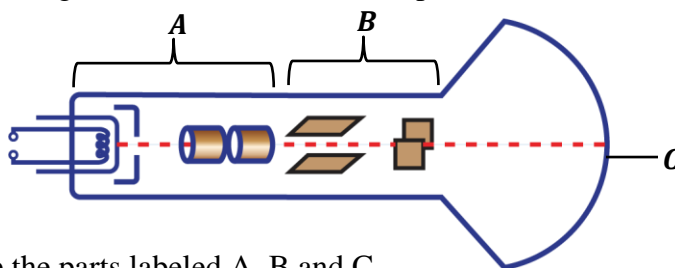

- a) i) Name the parts labeled A, B and C
 ii) Why is a C.R.O evacuated?
 b) i) Describe briefly the principle of operation of C.R.O
 ii) How is the bright spot formed on the screen of a C.R.O?
 c) Use diagrams to show what is observed on the screen of a C.R.O when
 i) The C.R.O is switched on and no signal is applied on the Y-plates
 ii) The time base is switched on and no signal is applied to the Y-plates
 iii) An alternating signal is applied to the Y-plates while the time base is switched off
 d) Give two uses of C.R.O
7. a) i) State the necessary conditions for production of x-rays
 ii) Distinguish between hard x-rays and soft x-rays
 b) i) Draw a labeled diagram of an x-ray tube
 ii) Describe how the penetration power of the x-rays produced by the tube may be adjusted
 iii) Mention two applications of x-rays
 c) What is meant by the following?
 i) Radioactivity
 ii) Half-life
 d) A radioactive substance is found to have a half-life of 5 days. If after 15 days, 125g of it is remaining, what amount was present at the beginning?

Ans: [1000g]

8. a) What are x-rays
 b) With the aid of a labeled diagram, describe the structure and operation of x-ray tube
 c) Explain briefly how each of the following can be increased in an x-ray tube
 i) Intensity of x-rays
 ii) Penetrating power of x-rays

- d) State four ways in which x-rays are similar to gamma rays
- e) Give two biological uses of x-rays
9. a) i) Distinguish between nuclear fission and nuclear fusion
ii) State one example where nuclear fusion occurs naturally
- b) State one use of nuclear fission
- c) The following nuclear reaction takes place when a neutron bombards a sulphur atom
- $${}^{34}_{16}\text{S} + {}^1_0\text{n} \longrightarrow {}^a_b\text{Y}$$
- i) Describe the composition of the nuclide, Y formed
- ii) The nuclide, Y decays by emission of an α - particle and a γ - ray. Find the changes in mass number and atomic number of the nuclide, Y
- iii) State two properties of α - particles
- d) The half-life of the isotope, Cobalt-60, is 5 years. What fraction of the isotope remains after 15 years?

Ans: $[\frac{1}{8}]$

- e) State i) One medical use of radioisotopes
ii) Two ways of minimizing the hazardous effects of radiation from radioactive materials
10. a) Define half-life of a radioactive substance
- b) The mass of a radioactive substance decays to $\frac{1}{16}$ of its original mass after 16 days.

What is

- i) its half-life
- ii) Fraction of the original mass will have decayed after 20 days

Ans: i) [4 days]



- i) Identify the particles or radiations A, B and C emitted in the decay process shown above
- ii) State two differences between radiations A and B
- iii) Name two health hazards of radioactivity
- d) What is the difference between nuclear fission and nuclear fusion?
11. a) Define the following terms
- i) Atomic number ii) Mass number iii) Isotopes
- b) A radioactive nucleus decays by emission of alpha particles
- i) What is an alpha particle?
- ii) What changes occur in mass number and atomic number when an alpha particle is emitted?
- iii) State any three differences between alpha particles and beta particles
- c) The table shows the count rates of a certain radioactive material

Time (hour)	0	1	3	4	7	9
Counts rate (min^{-1})	6400	5380	3810	2700	1910	1350

Plot a suitable graph and use it to find half-life of the material.

Ans: [3.2 hours]

12. a) What is meant by the terms;

- i) Isotopes
 - ii) Atomic number
- b) i) Name and state the nature of emissions from radioactive nuclides
ii) What effect does each of the emissions have on the parent nuclide?
- c) A radioactive sample has a half-life of 3×10^3 years
- i) What does the statement half-life of 3×10^3 years mean?
 - ii) How long does it take for three-quarters of the sample to decay?

Ans: ii) [6.0×10^3 years]

d) Give two uses of radioactivity.

13. a) A radioactive nuclide decays by emission of two alpha particles and two beta particles to nuclide, Y

- i) What is meant by radioactive nuclide?
 - ii) Give three differences between alpha and beta alpha particles
 - iii) State atomic number and mass number of Y
- b) What precautions would have to be taken when handling radioactive materials?
- c) A certain radioactive material contains 2.7×10^{24} atoms. How many atoms will have decayed after 32000 years if the half- life of the material is 800years?

Ans: [2.53125×10^{24} atoms]

d) Explain briefly one industrial application of radioactivity.

14. The figure below shows the main parts of an x-ray tube

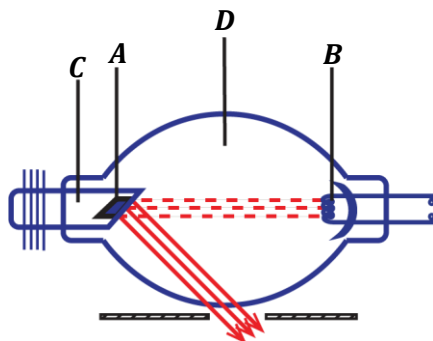

- a) Name the parts labeled A, B, C and D
- b) List in order the energy changes which occur in the x-ray tube
- c) Describe one industrial use of x-rays
- d) i) What is meant by the half-life of a radioactive material
ii) The activity of a radioactive source decreases from 4000 counts per minute to 250 counts per minute in 40 minutes. What is the half-life of the source?
iii) A carbon source of half-life 6 days initially contains 8×10^6 atoms. Calculate the time taken for 7.75×10^6 atoms to decay.

Ans: ii) [10 minutes] iii) [30 days]

15. a) Define the following terms as used in nuclear reactions

- i) Fusion
 - ii) Fission
 - iii) Activity
- b) Describe a simple model of an atom

c) Uranium, U has a mass number of 238 and atomic number of 92. It undergoes radioactive decay by emission of an alpha particle to form element X.

- i) Write down a nuclear equation reaction that takes place
- ii) State the mass number and atomic number of X

Ans: ii) [Mass Number = 234, Atomic Number = 90]

- d)
 - i) What is meant by half-life of radioactive substance
 - ii) The count rate of a radioactive isotope fall from 600 counts per second to 75 counts per second in 75 minutes. Calculate the half-life of the radioactive isotope.

Ans: ii) [25 minutes]

16. a) A radioactive nuclide ${}_{92}^{236}\text{U}$ decays by emission of two alpha particles and two beta particles to a nuclide Y

- i) What is meant by a radioactive nuclide?
- ii) State the mass number and atomic number of Y
- iii) Give four differences between alpha and beta particles

Ans: ii) [Mass Number = 234, Atomic Number = 90]

b) State four precautions that would have to be taken when handling radioactive materials

c) A certain mass of radioactive material contains 2.4×10^{12} radioactive atoms. How many atoms will have decayed after 3200 years if the half-life of the material is 800 years?

Ans: [2.25 × 10¹² atoms]

- d) Explain briefly one industrial application of radioactivity
- e) Briefly describe how full wave rectification can be achieved

17. a)

- i) What is meant by cathode rays
- ii) With the aid of a labeled diagram, describe how cathode rays are produced by thermionic effect

b) With reference to the cathode ray oscilloscope, describe

- i) The function of the time base
- ii) How the brightness is regulated

c) A cathode ray oscilloscope (C.R.O) with time base switched on is connected across a power supply. The waveform shown in the figure below is obtained

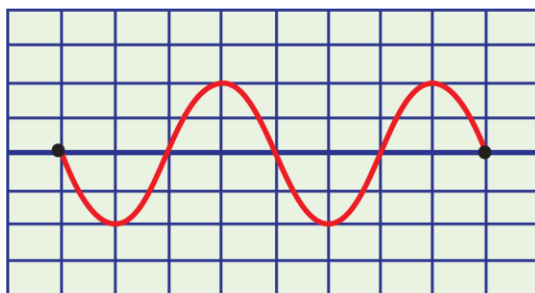

The distance between the lines is 1cm

- i) Identify the voltage generated by the power supply
- ii) Find the amplitude of the voltage generated if the voltage gain is $5V\text{cm}^{-1}$
- iii) Calculate the frequency of the power source if the time base setting on the C.R.O is $5.0 \times 10^{-3}\text{scm}^{-1}$

Ans: i) [10V] ii) [50Hz]

18. a) Describe a simple model of the atom
 b) Define the following
 i) Isotopes of an element
 ii) Atomic number
 c) State two differences between an alpha particle and a beta particle
 d) i) What is meant by nuclear fission and nuclear fusion
 ii) Give one example of where each one occurs
 e) The half-life of radioactive substance is 24 days. Calculate the mass of the substance which has decayed after 72 days if the original mass is 0.64g.

Ans: [0.56g]

19. a) Define the following terms
 i) Atomic number
 ii) Mass number
 b) A radioactive nuclide ${}_{19}^{42}\text{Y}$ decays by emission of both alpha & gamma radiations to a nuclide X
 i) Write a balanced equation for the nuclear reaction
 ii) Give three differences between beta and alpha particles
 c) State conditions required for each of the following to occur
 i) Fission
 ii) Fusion
20. a) i) Name the particles emitted by radioactive nuclides
 ii) Give two properties common to the particles named in (i) above
 b) A stream of particles from a radioactive source passes through a magnetic field directed into the plane of the paper as show below

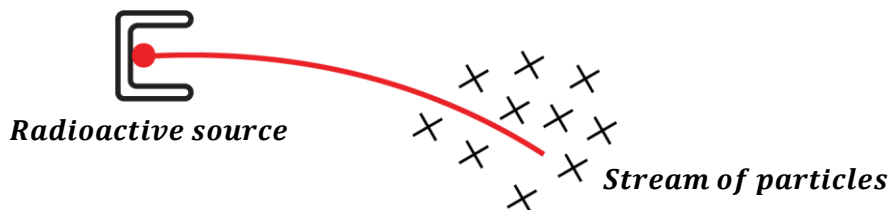

- i) Identify the particles in the stream
 ii) Sketch a diagram to show the path of the particles in an electric field

HEAT MEASUREMENT

Terminologies used:

i) Heat capacity, C:

This is the amount of heat required to raise the temperature of a body by 1K or 1°C.

$$\text{Heat capacity} = \frac{\text{Amount of heat}}{\text{Change in temperature}}$$

$$C = \frac{H}{\Delta\theta}$$

The SI unit of heat capacity is joules per Kelvin (J/K or JK⁻¹)

Also, *Heat capacity = mass × specific heat capacity*

$$\text{Heat capacity} = mc$$

ii) Specific heat capacity, c:

This is the amount of heat required to raise the temperature of 1kg mass of a substance by 1K or 1°C.

$$\text{Specific heat capacity} = \frac{\text{Amount of heat}}{\text{Mass} \times \Delta\theta}$$

$$c = \frac{H}{m \times \Delta\theta}$$

The SI unit of specific heat capacity is Joules per kilogram per Kelvin (J/kgK or Jkg⁻¹K⁻¹).

Quantity of heat, **H = mcΔθ**

Where Δθ – change in temperature.

c – Specific heat capacity

m – Mass of substance.

Note: Δθ = θ₂ – θ₁

N.B: The specific heat capacity is different for different substances and the table below shows values of specific heat capacities of some common substances.

Substance	Specific heat capacity (Jkg ⁻¹ K ⁻¹)
Water	4200
Ice	2100
Aluminium	900
Copper	400

NOTE:

Water has the highest specific heat capacity of 4200Jkg⁻¹K⁻¹. The high specific heat capacity of water makes water a very good liquid for cooling machines.

Question:

“The specific heat capacity of water is 4200Jkg⁻¹K⁻¹.” What is meant by the statement?

This means that 1kg mass of water requires 4200J of heat to raise its temperature by 1K.

Heat calculations

The following should be noted:

Always mass must be in Kilograms (kg)

In questions with the phrase “**the temperature rises by**” or “**the temperature rose by**”, the temperature value given is the change in temperature $\Delta\theta$

Examples:

1. How much heat is required to raise the temperature of 5kg of iron from 30°C to 40°C if the specific heat capacity of iron is $440\text{Jkg}^{-1}\text{K}^{-1}$?

$$H = mc\Delta\theta$$

$$H = 5 \times 440 \times (40 - 30)$$

$$H = 2200 \times 10$$

$$H = \mathbf{22000\text{J}}$$

2. When a block of iron of mass 2kg absorbs 19kJ of heat its temperature rises by 10°C . Find the specific heat capacity of iron.

$$H = mc\Delta\theta$$

$$19000 = 2 \times c \times 10$$

$$c = \frac{19000}{20}$$

$$c = \mathbf{950\text{Jkg}^{-1}\text{K}^{-1}}$$

3. How much heat is given out when an iron metal of mass 2 kg and specific heat capacity $460\text{Jkg}^{-1}\text{K}^{-1}$ cools from 300°C to 200°C .

$$H = mc\Delta\theta$$

$$H = 2 \times 460 \times (300 - 200)$$

$$H = 920 \times 100$$

$$H = \mathbf{92000\text{J}}$$

4. Calculate the specific heat capacity of gold if 108 J of heat raises the temperature of a 9g mass from 0°C to 100°C .

$$m = \frac{9}{1000} = 0.009\text{kg}$$

$$H = mc\Delta\theta$$

$$108 = 0.009 \times c \times (100 - 0)$$

$$108 = 0.9c$$

$$c = \frac{108}{0.9}$$

$$c = \mathbf{120\text{Jkg}^{-1}\text{K}^{-1}}$$

5. 5KJ of heat is supplied to a metal whose specific heat capacity is $400\text{Jkg}^{-1}\text{K}^{-1}$, if the temperature of the metal rises by 5K. Find the mass of the metal.

$$H = mc\Delta\theta$$

$$5000 = m \times 400 \times 5$$

$$5000 = 2000m$$

$$m = \mathbf{2.5\text{kg}}$$

SSEKWE ROBERT

6. 1200J of heat is supplied to 100g of water at 20°C. Calculate the final temperature of water if its specific heat capacity is $4200\text{Jkg}^{-1}\text{K}^{-1}$

$$m = \frac{100}{1000} = 0.1\text{kg}$$

$$H = mc\Delta\theta$$

$$1200 = 0.1 \times 4200 \times (\theta_2 - 20)$$

$$1200 = 420\theta_2 - 8400$$

$$1200 + 8400 = 420\theta_2$$

$$\theta_2 = \frac{9600}{420}$$

$$\theta_2 = 22.9^\circ$$

CALORIMETRY:

This is the measurement of flow of heat.

The instrument used in calorimetry is called calorimeter.

Calorimeter:

- It is made up of copper.
- It is lagged with an insulator and placed in a jacket with a plastic cover which has two holes for a thermometer and a stirrer.

METHODS OF MEASURING SPECIFIC HEAT CAPACITY:

There are two common methods namely;

- Electrical method.
- Method of mixtures.

Experiment to determine Specific heat capacity of a solid by electrical method.

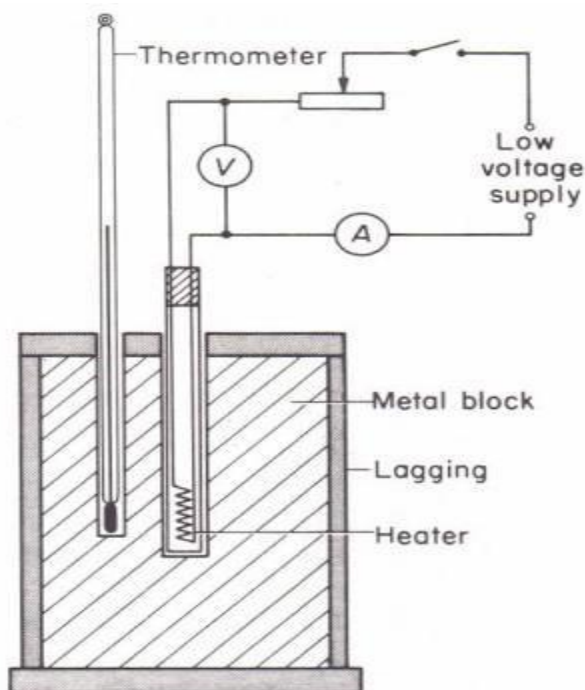

SSEKWE ROBERT

- A metal block of mass, m whose S.H.C is to be determined is drilled with two holes, one for thermometer and the other for heater. Both the heater and thermometer must be in good contact with the block.
- The initial temperature, θ_1 of the block is recorded from the thermometer before closing the switch.
- The heater is then switched on by closing switch, K until the temperature of block changes to θ_2 , in a given time, t .
- The ammeter and voltmeter readings I and V respectively are noted and recorded.

Assuming there are no heat losses,

Electrical heat supplied by heater = Heat gained by metal block

$$IVt = mc\Delta\theta \quad \text{But } \Delta\theta = \theta_2 - \theta_1$$

$$c = \frac{IVt}{mc(\theta_2 - \theta_1)}$$

But also power, $P = IV$

$$c = \frac{Pt}{mc(\theta_2 - \theta_1)} \quad \text{where } c \text{ is specific heat capacity}$$

Example:

1. 98,000J of electrical heat are needed to raise the temperature of 2kg of a substance from 51°C to 65°C . Calculate the specific heat capacity of a substance.

Electrical heat supplied = Heat gained by substance

$$IVt = mc\Delta\theta$$

$$IVt = mc(\theta_2 - \theta_1)$$

$$98000 = 2 \times c \times (65 - 51)$$

$$c = \frac{98000}{28}$$

$$c = \frac{98000}{28}$$

$$c = 3500\text{Jkg}^{-1}\text{K}^{-1}$$

2. A heater rated 2KW is used for heating the solid of mass 6kg, if its temperature rises from 30°C to 40°C . In 12s, find the S.H.C of the solid.

$$P = 2\text{ kW} = 2 \times 1000\text{ W}, \quad m = 6\text{ kg}$$

Electrical heat supplied = Heat gained by substance

$$IVt = mc\Delta\theta$$

$$Pt = mc(\theta_2 - \theta_1)$$

$$2000 \times 12 = 6 \times c \times (40 - 30)$$

$$c = \frac{24000}{60}$$

$$c = \frac{24000}{60}$$

$$c = 400\text{Jkg}^{-1}\text{K}^{-1}$$

Experiment to determine Specific heat capacity of a solid by method of mixtures.

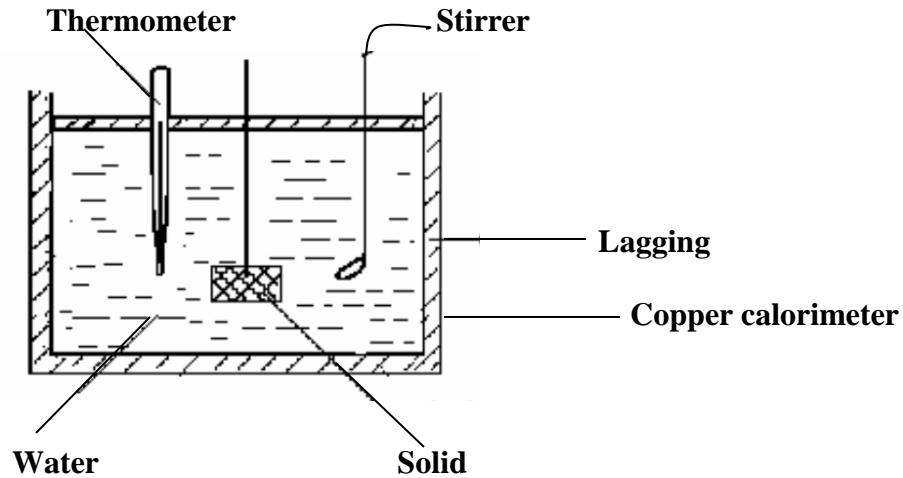

- A solid of mass, m_s whose specific heat capacity, c_s is required is heated to a temperature, θ_1 .
- A solid is then transferred quickly to a calorimeter of mass, m_c and specific heat capacity c_c containing water of mass, m_w both at a temperature, θ_2 .
- The mixture is well stirred until a steady final maximum temperature, θ_3 is reached.

Assuming there is no heat loss during the experiment,

Heat lost by solid = Heat gained by water + Heat gained by calorimeter

$$m_s c_s \Delta\theta = m_w c_w \Delta\theta + m_c c_c \Delta\theta$$

$$m_s c_s (\theta_1 - \theta_3) = m_w c_w (\theta_3 - \theta_2) + m_c c_c (\theta_3 - \theta_2)$$

$$c_s = \frac{m_w c_w (\theta_3 - \theta_2) + m_c c_c (\theta_3 - \theta_2)}{m_s (\theta_1 - \theta_3)}$$

- Hence specific heat capacity, c_s of a solid can be calculated

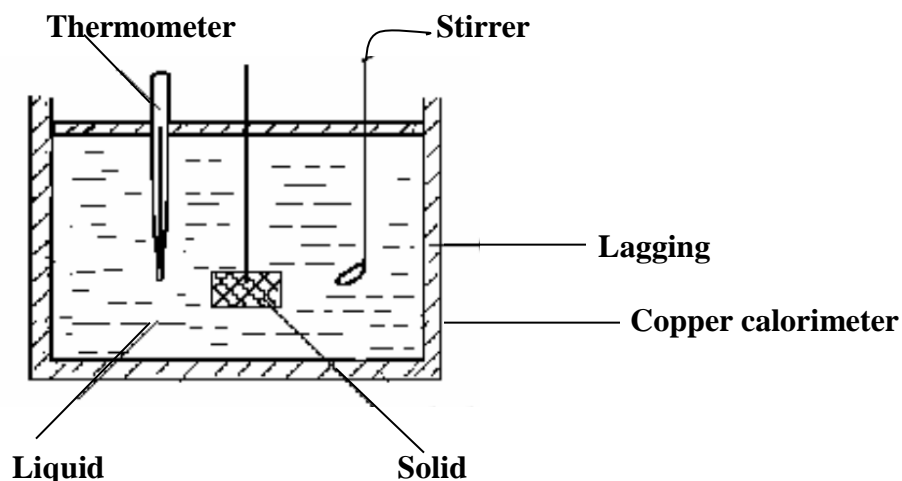
Experiment to determine Specific heat capacity of a liquid by method of mixtures.

- A solid of mass, m_s and specific heat capacity, c_s is heated to a temperature, θ_1 .
- A solid is then transferred quickly to a calorimeter of mass, m_c and specific heat capacity c_c containing a liquid of mass, m_l whose specific heat capacity c_l is required both at a temperature, θ_2 .
- The mixture is well stirred until a steady final maximum temperature, θ_3 is reached.

Assuming there is no heat loss during the experiment,

Heat lost by solid = Heat gained by liquid + Heat gained by calorimeter

$$m_s c_s \Delta\theta = m_l c_l \Delta\theta + m_c c_c \Delta\theta$$

$$m_s c_s (\theta_1 - \theta_3) = m_l c_l (\theta_3 - \theta_2) + m_c c_c (\theta_3 - \theta_2)$$

$$c_l = \frac{m_s c_s (\theta_1 - \theta_3) - m_c c_c (\theta_3 - \theta_2)}{m_l (\theta_3 - \theta_2)}$$

- Hence specific heat capacity, c_l of a liquid can be calculated.

Examples:

1. A piece of metal of mass 0.5kg is heated to 100°C and then placed in 0.4kg of water at 10°C, if the final temperature of the mixture is 30°C. Calculate the specific heat capacity of the metal. (Neglect heat absorbed by container with water and S.H.C of water is 4200Jkg⁻¹K⁻¹)

Heat lost by the metallic solid = Heat gained by water

$$m_s c_s \Delta\theta = m_w c_w \Delta\theta$$

$$0.5 \times c_s \times (100 - 30) = 0.4 \times 4200 \times (30 - 10)$$

$$35c_s = 33600$$

$$c_s = \frac{33600}{35}$$

$$c_s = 960 \text{ Jkg}^{-1} \text{ K}^{-1}$$

2. The temperature of a piece of copper of mass 250g is raised to 100°C and it is then transferred to a well-lagged aluminum can of mass 10.0g containing 120g of methylated spirit at 10.0°C. Calculate the final steady temperature after the spirit has been well stirred. Neglect the heat capacity of the stirrer and any losses from evaporation. (S.H.C of copper, aluminum and spirit respectively = 400 J kg⁻¹ K⁻¹, = 900 J kg⁻¹ K⁻¹, = 2400 J kg⁻¹ K⁻¹)

$$\theta_1 = 100^\circ\text{C}, \theta_2 = 10^\circ\text{C}, \theta_3 = ?$$

Heat lost by copper piece = Heat gained by spirit + Heat gained by aluminium can

$$m_C c_C \Delta\theta = m_S c_S \Delta\theta + m_A c_A \Delta\theta$$

$$m_C c_C (\theta_1 - \theta_3) = m_S c_S (\theta_3 - \theta_2) + m_A c_A (\theta_3 - \theta_2)$$

$$\frac{250}{1000} \times 400 \times (100 - \theta_3) = \frac{120}{1000} \times 2400 \times (\theta_3 - 10) + \frac{10}{1000} \times 900 \times (\theta_3 - 10)$$

$$100 \times (100 - \theta_3) = 288(\theta_3 - 10) + 9(\theta_3 - 10)$$

$$10000 - 100\theta_3 = 288\theta_3 - 2880 + 9\theta_3 - 90$$

$$288\theta_3 + 9\theta_3 + 100\theta_3 = 10000 + 2880 + 90$$

$$397\theta_3 = 12970$$

$$\theta_3 = \frac{12970}{397}$$

$$\theta_3 = 32.7^\circ\text{C}$$

3. A metal of mass 0.2kg at 100°C is dropped into 0.08kg of water at 13°C contained in calorimeter of mass 0.12kg and S.H.C 400Jkg⁻¹K⁻¹. The final temperature reached is 35°C. Determine the S.H.C of the metal

$$m_M = 0.2\text{kg}, \theta_1 = 100^\circ\text{C},$$

$$m_W = 0.08\text{kg}, \theta_2 = 13^\circ\text{C}, c_W = 4200\text{Jkg}^{-1}\text{K}^{-1}$$

$$m_C = 0.12\text{kg} \quad c_C = 400\text{Jkg}^{-1}\text{K}^{-1}$$

$$\theta_3 = 35^\circ\text{C}$$

Heat lost by metal = Heat gained by water + Heat gained by calorimeter

$$m_M c_M \Delta\theta = m_W c_W \Delta\theta + m_C c_C \Delta\theta$$

$$m_M c_M (\theta_1 - \theta_3) = m_W c_W (\theta_3 - \theta_2) + m_C c_C (\theta_3 - \theta_2)$$

$$0.2 \times c_M \times (100 - 35) = 0.08 \times 4200 \times (35 - 13) + 0.12 \times 400(35 - 13)$$

$$13c_M = 6720 + 960$$

$$13c_M = 7680$$

$$c_M = \frac{7680}{13}$$

$$c_M = 590.78\text{Jkg}^{-1}\text{K}^{-1}$$

4. A liquid of mass 200g in a calorimeter of heat capacity 500 $\text{Jkg}^{-1}\text{K}^{-1}$ and mass 1kg is heated such that its temperature changes from 25°C to 50°C. Find the S.H.C of the liquid if the heat supplied was 14,000J.

Heat supplied = heat gained by liquid + heat gained by calorimeter

$$\begin{aligned}
 H &= m_l c_l \Delta\theta + m_c c_c \Delta\theta \\
 H &= m_l c_l (\theta_2 - \theta_1) + m_c c_c (\theta_2 - \theta_1) \\
 14000 &= \frac{200}{1000} \times c_l \times (50 - 25) + 1 \times 500 \times (50 - 25) \\
 14000 &= 5c_l + 12500 \\
 1500 &= 5c_l \\
 c_l &= \frac{1500}{5} \\
 c_l &= 300 \text{Jkg}^{-1}\text{K}^{-1}
 \end{aligned}$$

5. 450g of water at 60°C is to be cooled to 35°C by addition of cold water at 20°C. Calculate the mass of cold water added. (S.H.C of water is 4200 $\text{Jkg}^{-1}\text{K}^{-1}$)

Heat lost by hot water = Heat gained by cold water

$$\begin{aligned}
 m_{hw} c_{hw} \Delta\theta &= m_{cw} c_{cw} \Delta\theta \\
 \frac{450}{1000} \times 4200 \times (60 - 35) &= m_{cw} \times 4200 \times (35 - 20) \\
 47250 &= 63000 m_{cw} \\
 m_{cw} &= \frac{47250}{63000} \\
 m_{cw} &= 0.75 \text{kg}
 \end{aligned}$$

6. Hot water of mass 0.4kg at 100°C is poured into calorimeter of mass 0.3kg and S.H.C of 400 $\text{Jkg}^{-1}\text{K}^{-1}$ and contains 0.2kg of a liquid at 10°C. The final temperature of mixture is 40°C determines the S.H.C of a liquid. (S.H.C of water is 4200 $\text{Jkg}^{-1}\text{K}^{-1}$)

$$\begin{aligned}
 m_w &= 0.4 \text{kg}, \theta_1 = 100^\circ\text{C} \\
 m_l &= 0.2 \text{kg}, \theta_2 = 10^\circ\text{C} \\
 m_c &= 0.3 \text{kg}, c_c = 400 \text{Jkg}^{-1}\text{K}^{-1} \\
 \theta_3 &= 40^\circ\text{C} \\
 \text{Heat lost by hot water} &= \text{Heat gained by liquid} + \text{Heat gained by calorimeter} \\
 m_w c_w \Delta\theta &= m_l c_l \Delta\theta + m_c c_c \Delta\theta \\
 m_w c_w (\theta_1 - \theta_3) &= m_l c_l (\theta_3 - \theta_2) + m_c c_c (\theta_3 - \theta_2) \\
 0.4 \times 4200 \times (100 - 40) &= 0.2 \times c_l \times (40 - 10) + 0.3 \times 400 \times (40 - 10) \\
 100800 &= 6c_l + 3600 \\
 6c_l &= 97200 \\
 c_l &= \frac{97200}{6} \\
 c_l &= 16200 \text{Jkg}^{-1}\text{K}^{-1}
 \end{aligned}$$

SSEKWE ROBERT

NOTE: Since mass is proportional to volume, then mass of liquid is equal to its volume for a unit substance.

7. A copper metal of mass 250g is heated to 145°C and then placed in a copper calorimeter of mass 250g which contains 250cm³ of water at 20°C. Calculate the maximum temperature attained by water [specific heat capacity of water is 4200Jkg⁻¹K⁻¹ and specific heat capacity of copper is 400Jkg⁻¹K⁻¹]

$$m_{CM} = 250g, \theta_1 = 145^\circ\text{C}, c_{CM} = 400\text{Jkg}^{-1}\text{K}^{-1}$$

$$m_W = 250\text{cm}^3 = 250g, \theta_2 = 20^\circ\text{C}$$

$$m_C = 250g, c_C = 400\text{Jkg}^{-1}\text{K}^{-1}$$

$$\theta_3 = ?$$

Heat los by copper metal = Heat gained by water + Heat gained by calorimeter

$$m_{CM}c_{CM}\Delta\theta = m_Wc_W\Delta\theta + m_Cc_C\Delta\theta$$

$$m_{CM}c_{CM}(\theta_1 - \theta_3) = m_Wc_W(\theta_3 - \theta_2) + m_Cc_C(\theta_3 - \theta_2)$$

$$\frac{250}{1000} \times 400 \times (145 - \theta_3) = \frac{250}{1000} \times 4200 \times (\theta_3 - 20) + \frac{250}{1000} \times 400 \times (\theta_3 - 20)$$

$$100(145 - \theta_3) = 1050(\theta_3 - 20) + 100 \times (\theta_3 - 20)$$

$$14500 - 100\theta_3 = 1050\theta_3 - 2100 + 100\theta_3 - 2000$$

$$1050\theta_3 + 100\theta_3 + 100\theta_3 = 14500 + 2100 + 2000$$

$$1250\theta_3 = 37500$$

$$\theta_3 = \frac{37500}{1250}$$

$$\theta_3 = 30^\circ\text{C}$$

PRECAUTIONS TAKEN WHEN USING METHOD OF MIXTURES

- The solid/specimens should be transferred as quickly as possible to the calorimeter to avoid heat losses.
- The calorimeter must be insulated.
- Stirring must be done to ensure uniform distribution of heat.
- The calorimeter must be polished inside to avoid heat loss by radiation.

EXERCISE

- 1) A piece of copper of mass 100g is heated to 100°C and is then transferred to a well lagged copper can of mass 50g containing 200g of water at 10°C. Neglecting heat loss, calculate the final steady temperature of water after it has been well stirred. Take S.H.C of copper and water to be 400Jkg⁻¹K⁻¹ and 4200Jkg⁻¹K⁻¹ respectively. **Ans; [14°C]**

SSEKWE ROBERT

- 2) A heating coil is placed in thermal flask containing 0.6kg of water for 600s. The temperature of water rises by 25°C during this time. Water is replaced by 0.4kg of another liquid. And the same temperature rise occurs in 180s. Calculate the S.H.C of the liquid given that S.H.C of water is 4200Jkg⁻¹K⁻¹. State any assumption. **Ans; [1890Jkg⁻¹K⁻¹]**
- 3) Copper calorimeter of mass 120g contains 100g of paraffin at 15°C. If 45g of aluminum at 100°C is transferred to the liquid and the final temperature is 27°C. Calculate the S.H.C of paraffin [S.H.C of aluminum and copper are 1000 Jkg⁻¹K⁻¹ and 400 Jkg⁻¹K⁻¹ respectively]. **Ans; [2.4 x10³Jkg⁻¹K⁻¹]**
- 4) A liquid of mass 250g is heated to 80°C and then quickly transferred to a calorimeter of heat capacity 380JK⁻¹ containing 400g of water at 30°C. If the maximum temperature recorded is 55°C and specific heat capacity of water is 4200Jkg⁻¹K⁻¹. Calculate the S.H.C of the liquid. **Ans; [8240Jkg⁻¹K⁻¹]**
- 5) 500g of water is put in a calorimeter of heat capacity 0.38JK⁻¹ and heated to 60°C. It takes 2minute for the water to cool from 60°C to 55°C. When the water is replaced with 600g of a certain liquid, it takes 1½ minutes for the liquid to cool from 60°C to 55°C. Calculate the S.H.C of the liquid. **Ans; [2624.8kgJ⁻¹K⁻¹]**
- 6) 400g of a liquid at a temperature 70°C is mixed with another liquid of mass 200g at a temperature of 25°C. Find the final temperature of the mixture, if the S.H.C of the liquid is 4200 J kg⁻¹ K⁻¹. **Ans; [55°C]**
- 7) 60 kg of hot water at 82°C was added to 300 kg of cold water at 10°C. Calculate the final temperature of the mixture (S.H.C of water =4200 J kg⁻¹ K⁻¹) **Ans; [=22°C]**
- 8) Calculate the final steady temperature obtained when 0.8 kg of glycerine at 25°C is put into a copper calorimeter of mass 0.5 kg at 0°C (S.H.C of copper =400 J kg⁻¹ K⁻¹, S. H. C of glycerine = 250 J kg⁻¹K⁻¹). **Ans; [12.5°C]**
- 9) A block of metal of mass 0.01 kg at a temperature of 100°C was dropped in a container of water at 20°C. The final temperature was 40°C. Calculate the S.H.C of the metal ,if S.H.C of water 4200 J kg⁻¹ K⁻¹. **Ans; [7000 Jkg⁻¹ K⁻¹]**
- 10) A copper block of mass 250g is heated to a temperature of 145°C and then dropped into a copper calorimeter of mass 250g which contains 2500m³ of water at 20°C. Calculate the final temperature of water. (S.H.C of copper = 400Jkg⁻¹ °C⁻¹, S.H.C of water = 4200 J kg⁻¹ °C⁻¹). **Ans; [30°C]**
- 11) The temperature of heat which raises the temperature of 0.1 kg of water from 25°C to 60°C is used to heat a metal rod of mass 1.7 kg and S.H.C of the rod was 20°C. Calculate the final temperature of the rod. **Ans; [48.8°C]**

LATENT HEAT (HIDDEN HEAT)

This is the amount of heat required to change the state of substance without change in temperature.

There are two types of latent heat namely:

- Latent heat of fusion
- Latent heat of vaporization

KINETIC THEORY EXPLANATION OF LATENT HEAT

Question: Explain why during change of state, the temperature of a substance remains constant

- According to kinetic theory, when a substance is changing state, there is no change in temperature because all the heat supplied is only used to break the intermolecular forces between the molecules and increase the molecular spacing of the substance.

Latent heat of fusion:

This is the amount of heat required to change a substance from solid state to liquid state at constant temperature.

Specific latent heat of fusion (L_f):

This is the amount of heat required to change 1kg mass of substance from solid state to liquid state at constant temperature.

Heat required = mass × specific latent heat of fusion

$$H = mL_f$$

The SI unit of specific latent heat of fusion is Jkg^{-1}

Examples:

1. The specific latent heat of fusion of ice is $340,000 \text{ Jkg}^{-1}$. What do you understand by this statement?

It means that 1kg of ice needs 34,000J of heat energy to change to a liquid.

2. How much heat is needed to melt 10g of ice at 0°C ? [Specific latent heat of fusion of ice = $3.36 \times 10^5 \text{ Jkg}^{-1}$]

$$\begin{aligned} H &= mL_f \\ H &= \frac{10}{1000} \times 3.36 \times 10^5 \\ H &= 3.36 \times 10^3 \text{ J} \end{aligned}$$

Experiment to determine specific latent heat of fusion of ice by electrical method.

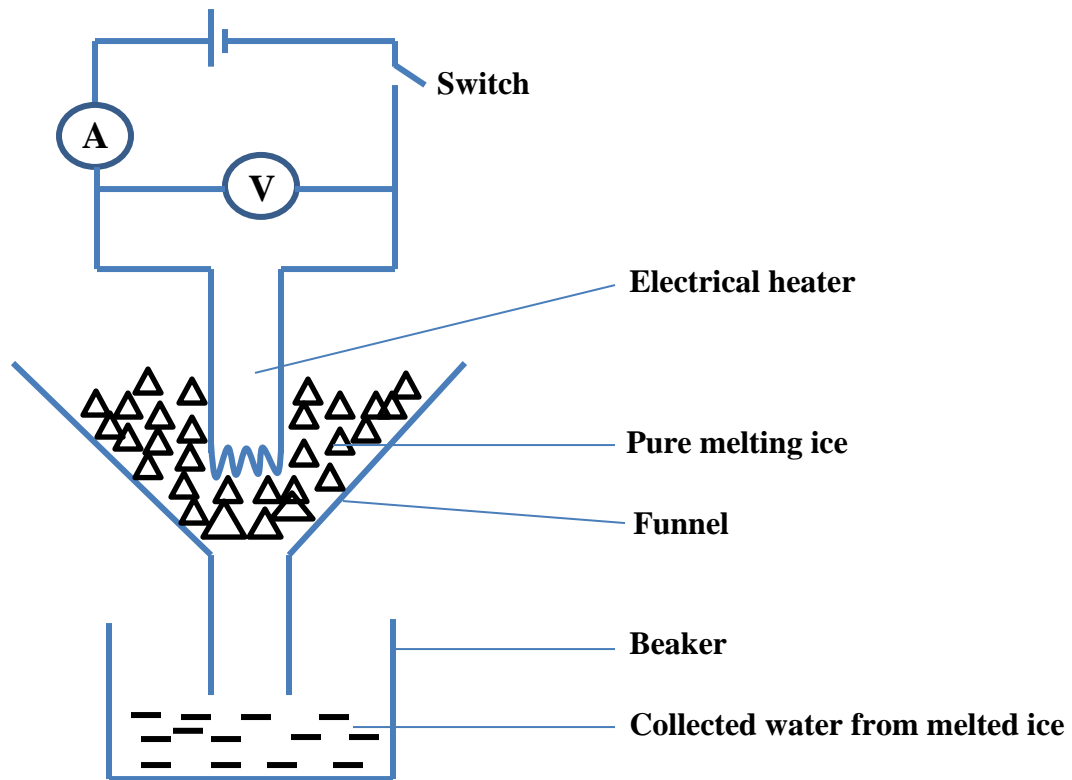

- An electrical heater is placed in a funnel.
- Small pieces of ice are packed around the heater.
- The heater is then switched on for a known time, t .
- The ammeter and voltmeter readings I and V respectively are noted and recorded.
- The mass, m of collected water from melted ice is measured and recorded
- Assuming there are no heat losses in the experiment,

Heat supplied by the heater = Heat gained by ice to melt

$$IVt = mL_f$$

$$L_f = \frac{IVt}{m}$$

But also power, $P = IV$

Therefore, $L_f = \frac{Pt}{m}$

- Hence specific latent heat of fusion of ice L_f can be calculated.

Examples;

1. A 3kW electrical heater is left for 2 minutes in a container packed with ice at 0°C. If 100g of ice melted into water, calculate the specific latent of fusion of Ice.

$$P = 3kW = 3 \times 1000 = 3000W, \quad t = 2minutes = 2 \times 60 = 120s$$

$$m = 100g = \frac{100}{1000} = 0.1kg$$

$$IVt = mL_f$$

$$\text{But } P = IV, \quad L_f = \frac{Pt}{m}$$

$$L_f = \frac{3000 \times 120}{0.1}$$

$$L_f = 3600,000Jkg^{-1}$$

Note:

If the ice is not at its melting point 0°C, the heat supplied first increases/raises its temperature to 0°C.

Therefore ,

Heat supplied = Heat to raise temperature of ice to 0°C + Heat to melt the ice

$$H = mc\Delta\theta + mL_f$$

2. How much heat is needed to melt 10g of ice at -10°C to water at 0°C? [Specific latent heat of fusion of ice = 3.36×10^5 kg and specific heat capacity of ice = $2100Jkg^{-1}K^{-1}$]

Heat = Heat that raises temperature of ice from -10°C to 0°C + Heat to melt ice

$$H = m_i c_i \Delta\theta + m_i L_f$$

$$H = \frac{10}{1000} \times 2100 \times (0 - (-10)) + \frac{10}{1000} \times 3.36 \times 10^5$$

$$H = 210 + 3360$$

$$H = 3570J$$

Experiment to determine specific latent heat of fusion of ice by method of mixtures.

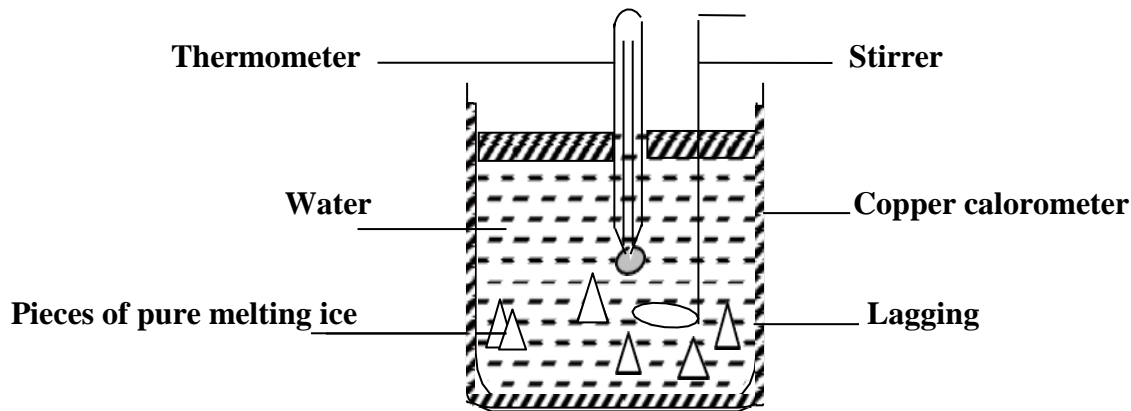

- Hot water of mass, m_w and specific heat capacity, c_c is poured in a calorimeter of mass, m_c and specific heat capacity, c_c .
- The initial temperature θ_1 of the hot water and calorimeter is then recorded from the thermometer.
- Small pieces of pure melting ice at 0°C are placed in a calorimeter.
- Stir the mixture gently until all the ice melts.
- The final steady temperature, θ_2 of the mixture is recorded from the thermometer.
- Weigh the calorimeter and its contents and determine the mass, m_i of melted ice from

$$m_i = (m_w + m_c + m_i) - (m_w + m_c)$$

- Assuming there are no heat losses

Heat gained by ice and cold water from melting ice = Heat lost by hot water and calorimeter.

$$m_i L_f + m_i c_w \Delta\theta = m_{hw} c_{hw} \Delta\theta + m_c c_c \Delta\theta$$

$$m_i L_f + m_i c_w (\theta_2 - 0) = m_{hw} c_{hw} (\theta_1 - \theta_2) + m_c c_c (\theta_1 - \theta_2)$$

$$L_f = \frac{m_{hw} c_{hw} (\theta_1 - \theta_2) + m_c c_c (\theta_1 - \theta_2) - m_i c_w \theta_2}{m_i}$$

Latent heat of vaporization:

This is the amount of heat required to change a substance from liquid state to gaseous state at constant temperature.

Specific latent heat of vaporization, L_v :

This is the amount of heat required to change 1kg mass of a substance from liquid state to gaseous state constant temperature.

The SI unit of specific latent heat of vaporization is Jkg^{-1} .

Heat required = mass \times specific latent heat of vaporization

$$H = mL_v$$

Example:

1. How much heat is needed to change 10g of water at 100°C to steam at constant temperature?
 [Specific latent heat of vaporization of water = 2.3×10^6 kg]

$$H = mL_v$$

$$H = \frac{10}{1000} \times 2.3 \times 10^6$$

$$H = 23000J$$

Experiment to determine specific latent heat of fusion of steam by method of mixtures.

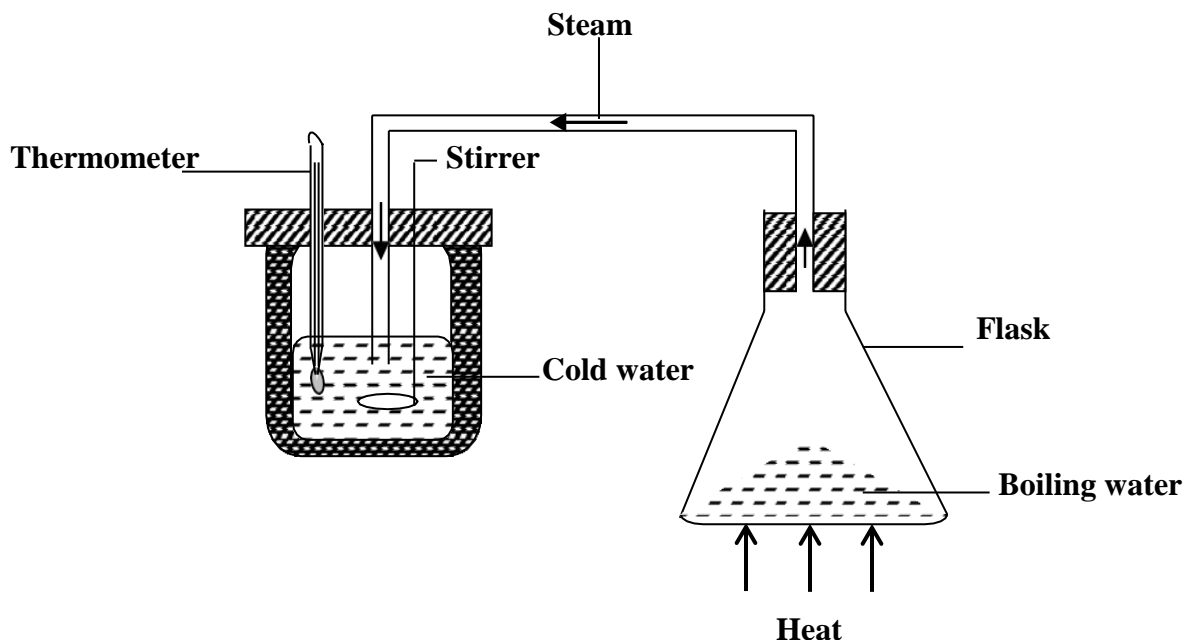

- Cold water of mass, m_w and specific heat capacity, c_c is poured in a calorimeter of mass, m_c and specific heat capacity, c_c .
- The initial temperature, θ_1 of cold water and calorimeter is recorded.
- Steam from pure boiling water at 100°C is passed through the cold water in the calorimeter.
- Stir the mixture gently until a steady final temperature, θ_2 is reached.
- Weigh the calorimeter and its contents to determine the mass, m_s of condensed steam from,

$$m_s = (m_s + m_w + m_c) - (m_w + m_c)$$
- Assuming there is no heat loss during the experiment.

Heat lost by steam and condensed water = Heat gained by cold water and calorimeter

$$m_s L_v + m_s c_w \Delta\theta = m_w c_w \Delta\theta + m_c c_c \Delta\theta$$

$$m_s L_v + m_s c_w (100 - \theta_2) = m_w c_w (\theta_2 - \theta_1) + m_c c_c (\theta_2 - \theta_1)$$

$$L_v = \frac{m_w c_w (\theta_2 - \theta_1) + m_c c_c (\theta_2 - \theta_1) - m_s c_w (100 - \theta_2)}{m_s}$$

- Hence specific latent heat of vaporization of steam, L_v can be calculated.

Examples:

1. A calorimeter of mass 35.0g and specific heat capacity of $840\text{Jkg}^{-1}\text{K}^{-1}$ contains 143.0g of water at 7°C . Dry steam at 100°C is passed through the water in the calorimeter until the temperature of water rises up to 29°C . If the mass of steam which condenses is 5.6g, calculate

- i) The heat gained by water and calorimeter
 ii) Specific latent heat of vaporization of water

(S.H.C of water $4200\text{Jkg}^{-1}\text{K}^{-1}$)

$$\theta_1 = 7^\circ\text{C}, \quad \theta_2 = 29^\circ\text{C}, \quad m_c = 35.0\text{g}, m_w = 143.0\text{g}, m_s = 5.6\text{g}$$

i)

$$\text{Heat gained by water and calorimeter} = m_w c_w \Delta\theta + m_c c_c \Delta\theta$$

$$\text{Heat gained by water and calorimeter} = m_w c_w (\theta_2 - \theta_1) + m_c c_c (\theta_2 - \theta_1)$$

$$\text{Heat gained} = \frac{143}{1000} \times 4200 \times (29 - 7) + \frac{35}{1000} \times 840 \times (29 - 7)$$

$$\text{Heat gained} = 13213.2 + 646.8$$

$$\text{Heat gained} = 13860\text{J}$$

ii)

$$\text{Heat lost by steam and condensensed water} = \text{Heat gained by water and calorimeter}$$

$$m_s L_v + m_s c_w \Delta\theta = 13860$$

$$m_s L_v + m_s c_w (100 - \theta_2) = 13860$$

$$\frac{5.6}{1000} \times L_v + \frac{5.6}{1000} \times 4200 \times (100 - 29) = 13860$$

$$0.0056 L_v = 13860 - 1669.92$$

$$L_v = \frac{12190.08}{0.0056}$$

$$L_v = 2,176,800\text{Jkg}^{-1}$$

2. The temperature of water of mass 2kg and specific heat capacity of $4200\text{Jkg}^{-1}\text{K}^{-1}$ is raised from 20°C to 80°C by steam at 100°C . Calculate the mass of steam needed if the specific latent heat of vaporization of water is $2.3 \times 10^6\text{Jkg}^{-1}\text{K}^{-1}$. (Neglect heat absorption by container with water)

$$\text{Heat lost by steam and condensensed water} = \text{Heat gained by water and calorimeter}$$

$$m_s L_v + m_s c_w \Delta\theta = m_w c_w \Delta\theta$$

$$m_s L_v + m_s c_w (100 - \theta_2) = m_w c_w (\theta_2 - \theta_1)$$

$$m_s \times (2.3 \times 10^6) + m_s \times 4200 \times (100 - 80) = 2 \times 4200 \times (80 - 20)$$

$$2300000m_s + 84000m_s = 504000$$

$$2384000m_s = 504000$$

$$m_s = \frac{504000}{2384000}$$

$$m_s = 0.211\text{kg}$$

NOTE:

If the water is not at its boiling point 100°C , the heat supplied first increases/raises its temperature to 100°C so as to be converted to vapour.

SSEKWE ROBERT

3. How much heat is needed to melt 10g of ice at -10°C to steam at 100°C ?

[Specific latent heat of fusion of ice = $3.36 \times 10^5 \text{Jkg}^{-1}$, specific heat capacity of ice = $2100 \text{Jkg}^{-1}\text{K}^{-1}$, specific heat capacity of water = $4200 \text{Jkg}^{-1}\text{K}^{-1}$, specific latent heat of vaporization of water = $2.3 \times 10^6 \text{Jkg}^{-1}$]

Heat supplied =

heat to raise temperature of ice from -10°C to 0°C + heat to melt ice +

heat to raise temperature of water from melted ice + heat to change water to steam

$$H = m_i c_i \Delta\theta + m_i L_f + m_i c_w \Delta\theta + m_i L_v$$

$$H = \frac{10}{1000} \times 2100(0 - (-10)) + \frac{10}{1000} \times 3.36 \times 10^5 + \frac{10}{1000} \times 4200 \times (100 - 0) + \frac{10}{1000} \times 2.3 \times 10^6$$

$$H = 210 + 3360 + 4200 + 23000$$

$$H = 30770\text{J}$$

4. Find the heat required to change 2 kg of ice at 0°C into water at 50°C .

(S.L.H of fusion of ice = $3.36 \times 10^5 \text{Jkg}^{-1}$, S.H.C of water = $4200 \text{Jkg}^{-1}\text{K}^{-1}$).

Heat required =

heat to melt ice to water + heat to raise temperature of water to 50°C

$$H = m_i L_f + m_i c_w \Delta\theta$$

$$H = 2 \times 3.36 \times 10^5 + 2 \times 4200 \times (50 - 0)$$

$$H = 672000 + 420000$$

$$H = 1,092,000\text{J}$$

5. An ice making machine removes heat from water at a rate of 20Js^{-1} . How long will it take to convert 0.5kg of water at 20°C to ice at 0°C . (S.L.H of fusion of ice = $3.36 \times 10^5 \text{Jkg}^{-1}$, S.H.C of water = $4200 \text{Jkg}^{-1}\text{K}^{-1}$).

$$P = 20 \text{Js}^{-1}, m_w = 0.5 \text{kg}$$

Heat gained by ice machine = Heat lost by water to 0°C + Heat to freeze water

$$P \times t = m_w c_w \Delta\theta + m_w L_f$$

$$20t = 0.5 \times 4200 \times (20 - 0) + 0.5 \times 3.36 \times 10^5$$

$$20t = 42000 + 168000$$

$$20t = 210000$$

$$t = \frac{210000}{20}$$

$$t = 10,500\text{s}$$

6. A calorimeter with heat capacity of $80 \text{J}^{\circ}\text{C}^{-1}$ contains 50g of water at 40°C . What mass of ice at 0°C needs to be added in order to reduce the temperature to 10°C . Assume no heat is lost to the surrounding (S.H.C of water = $4200 \text{Jkg}^{-1}\text{K}^{-1}$, S.L.H of fusion of ice = $3.4 \times 10^5 \text{Jkg}^{-1}$)

$$\theta_1 = 40^{\circ}\text{C}, \quad \theta_2 = 10^{\circ}\text{C}$$

Heat lost by water and calorimeter = Heat gained by ice to melt and cold water from ice

$$m_w c_w \Delta\theta + m_c c_c \Delta\theta = m_i L_f + m_i c_w \Delta\theta$$

$$m_w c_w (\theta_1 - \theta_2) + m_c c_c (\theta_1 - \theta_2) = m_i L_f + m_i c_w (\theta_2 - 0)$$

$$\frac{50}{1000} \times 4200 \times (40 - 10) + 80 \times 30 = m_i \times 3.4 \times 10^5 + m_i \times 4200 \times (10 - 0)$$

$$8700 = 382000 m_i$$

$$m_i = 0.023 \text{kg}$$

SSEKWE ROBERT

7. Steam at 100°C is passed into a copper calorimeter of mass 150g containing 340g of water at 15°C. This is done until the temperature of the calorimeter and its content is 71°C. If the mass of the calorimeter and its contents is found to be 525g. Calculate the specific latent heat of vaporization of water. (S.H.C of copper = 400Jkg⁻¹K⁻¹)

$$m_c = 150g, \quad m_w = 340g \quad \theta_1 = 15^\circ\text{C}, \quad \theta_2 = 71^\circ\text{C}, \quad m_c + m_s + m_w$$

$$m_s = (m_c + m_s + m_w) - (m_c + m_w) = 525 - (150 + 340) = 35g$$

Heat lost by steam and condensed water = Heat gained by cold water and calorimeter

$$m_s L_v + m_s c_w \Delta\theta = m_w c_w \Delta\theta + m_c c_c \Delta\theta$$

$$\frac{35}{1000} \times L_v + \frac{35}{1000} \times 4200 \times (100 - 71) = \frac{340}{1000} \times 4200 \times (71 - 15) + \frac{150}{1000} \times 400 \times (71 - 15)$$
$$0.035L_v + 4263 = 79968 + 3360$$
$$0.035L_v = 79065$$
$$L_v = \frac{79065}{0.035}$$
$$L_v = 2,259,000 \text{Jkg}^{-1}$$

EXERCISE:

- Ice at 0°C is added to 200g of water initially at 70°C in a vacuum flask. When 50g of ice is added and has all melted, the temperature of the flask and content is 40°C. When further 80g of ice has been added and has been melted, the temperature of the whole becomes 10°C. Calculate the S.L.H of fusion of ice neglecting any heat loss of surrounding.
Ans; [3.78x10⁵ Jkg⁻¹]
- Calculate the heat required to melt 200g of ice at 0°C . (S.L.H of ice= 3.4x10⁵Jkg⁻¹)
Ans; [6.8x10⁴ J]
- Calculate the heat required to turn 500g of Ice at 0°C into water at 100°C.
(S.L.H of ice= 3.4x10⁵Jkg⁻¹, S.H.C of water = 4200Jkg⁻¹)
Ans; [3.8x1]
- Calculate the heat given out when 600g of steam at 100°C condenses to water at 20°C [S.L.H of steam = 2.26x10⁶ Jkg⁻¹, S.H.C of water = 4200 Jkg⁻¹].
Ans; [1.56x10⁶J]
- 1kg of vegetables, having a specific heat capacity 2200 Jkg⁻¹ at a temperature 373K are plugged into a mixture of ice and water at 273K. How much is melted. [S.L.H of fusion of the ice = 3.3x10⁵ Jkg⁻¹]
Ans; [0.67kg]
- 0.02kg of ice and 0.10kg water at 0°C are in a container. Steam at 100°C is passed in until all the ice is just melted. How much water is now in the container? (S.L.H of vaporisation of steam = 2.3x10⁶Jkg⁻¹, S.L.H of fusion of ice = 3.4x10⁵Jkg⁻¹, S.H.C of water = 4.2 x10³Jkg⁻¹K⁻¹)
Ans; [0.1225kg]

QUESTION; Explain why specific latent heat of vaporization of a substance is always greater than specific latent heat of fusion the same substance e.g. (ice, water and steam)

- ✓ **For Latent heat of fusion (solid to liquid); heat required is small because it only slightly increases the molecular spacing by breaking the intermolecular forces.**
- ✓ **For latent heat of vaporization (liquid to gas); heat required is large because it has to increase the molecular spacing by breaking the intermolecular forces and also has to provide energy that enables molecules to escape from the surface of the liquid.**

NOTE: The phenomenon above explains why a person feels much heat when burnt by steam than when burnt by water at the same temperature.

EFFECTS OF HEAT ON MATTER:

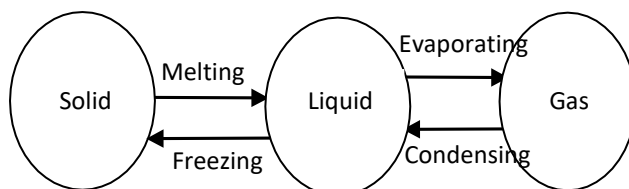

When a solid is heated it changes to a liquid at its **melting point**.

Definition:

Melting point is a constant temperature at which a solid changes to a liquid.

When a liquid is cooled it changes to a solid at its freezing point.

Definition:

Freezing point is a constant temperature at which a liquid changes to a solid.

When a liquid is heated it changes to a gas (vapour) at its boiling point.

Definition:

Boiling point is the constant temperature at which a liquid changes into a gas.

When a liquid is cooled it condenses and changes to a liquid.

HEATING AND COOLING CURVES (graphs of temperature against time)

The heating curve when ice below its melting point is heated.

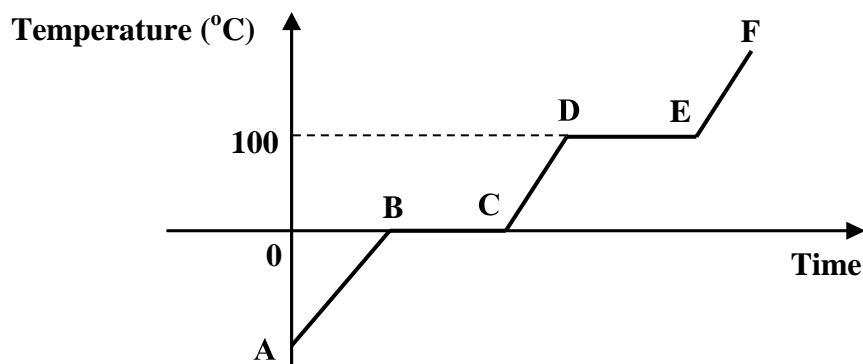

Explanation of the shape of graph.

AB: temperature of ice is increasing from A to its melting point 0°C

BC: ice is changing to water at 0°C

CD: the temperature of water is increasing from 0°C to *boiling point* 100°C

DE: water is changing to steam at 100°C

EF: temperature of steam is increasing

The states of water along different regions are;

AB – solid state (ice)

BC – solid state and liquid state (water + ice)

CD – liquid state (water)

DE – liquid state and gaseous state (water + vapour)

EF – gaseous state (steam or vapour)

The cooling curve when water above its boiling point is cooled

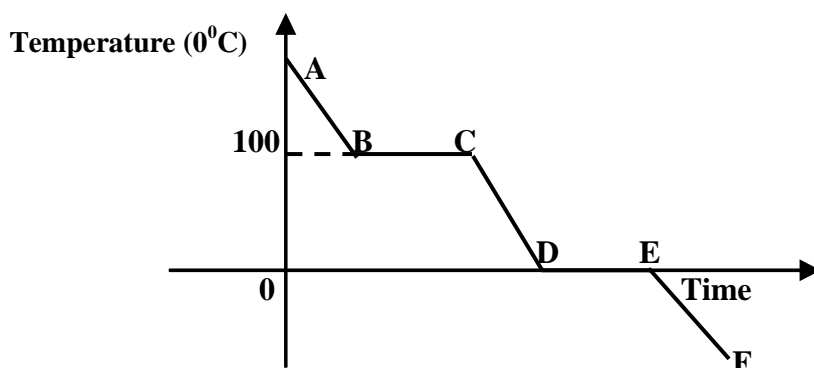

Explanation of shape of the graph

AB: temperature of steam is decreasing from to boiling point 100°C .

BC: steam is changing to water at 100°C

CD: the temperature of water is decreasing from 100°C to freezing point 0°C

DE: water is changing to ice at 0°C

EF: temperature of ice is decreasing

The states of water along different regions are;

EF – solid state (ice)

DE – solid state and liquid state (water + ice)

CD – liquid state (water)

BC – liquid state and gaseous state (water + vapour)

AB – gaseous state (steam or vapour)

Example:

1. 2kg of ice at -5°C was heated up to steam at 100°C .

- i) Sketch a temperature time graph curve for the ice up to steam
- ii) Find the heat at each section of the graph drawn. (S.H.C of ice = $2000 \text{ J kg}^{-1}\text{K}^{-1}$, S.H.C of water = $4200 \text{ J kg}^{-1}\text{K}^{-1}$, S.L.H. of fusion of ice = $3.36 \times 10^5 \text{ J kg}^{-1}$, S.L.H. of vaporization of water = $2.26 \times 10^6 \text{ J kg}^{-1}$)

i)

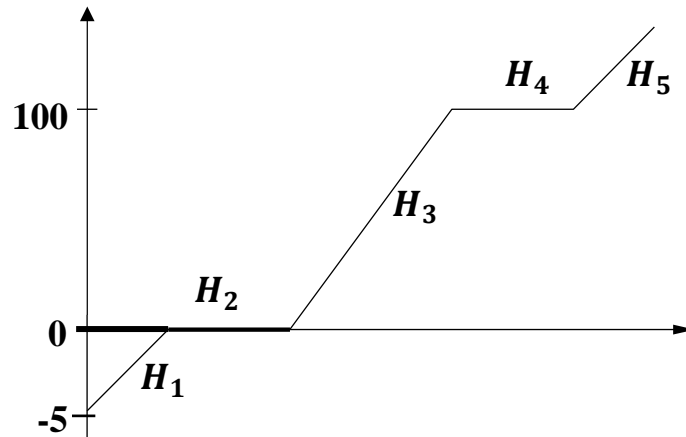

ii) H_1 temperature of ice increasing from -5°C to 0°C

$$H_1 = m_i c_i \Delta\theta$$

$$H_1 = 2 \times 2000 \times (0 - (-5))$$

$$H_1 = 20,000\text{J}$$

H_2 ice melting to water at 0°C

$$H_2 = m_i L_f$$

$$H_2 = 2 \times 3.36 \times 10^5$$

$$H_2 = 672,000\text{J}$$

H_3 temperature of water increasing from 0°C to 100°C

$$H_3 = m_w c_w \Delta\theta$$

$$H_3 = 2 \times 4200 \times (100 - 0)$$

$$H_3 = 84,000\text{J}$$

H_4 water changing to steam at 100°C

$$H_4 = m_w L_v$$

$$H_4 = 2 \times 2.26 \times 10^6$$

$$H_4 = 4,520,000\text{J}$$

EXERCISE:

Where necessary assume the following

Specific heat capacity of water	= 4200 Jkg ⁻¹ K ⁻¹
Specific heat capacity of copper	= 400 Jkg ⁻¹ K ⁻¹
Specific heat capacity of iron	= 450 Jkg ⁻¹ K ⁻¹
Specific heat capacity of aluminium	= 880 Jkg ⁻¹ K ⁻¹
Specific heat capacity of ice	= 2100 Jkg ⁻¹ K ⁻¹
Specific latent heat of fusion of ice	= 336,000 Jkg ⁻¹
Specific latent heat of vaporization of water	= 2,250,000 Jkg ⁻¹

- How much heat is required to raise the temperature of 50g of aluminium from -100°C to 120°C?
Ans: 9,680J
- If 98,000J of heat are needed to raise the temperature of 2kg of a substance from 51°C to 65°C. What is the specific heat capacity of a substance?
Ans: 3500Jkg⁻¹K⁻¹
- An electric fire has a power of 1,800W. When used to heat a liquid of 5kg, it takes 6 minutes to raise the temperature by 90°C. What is the specific heat capacity of the liquid?
Ans: 1440 Jkg⁻¹K⁻¹
- A 30g block of copper is heated from -20°C to 180°C. How much heat does it absorb during heating?
Ans: 2400J
- How much heat energy is needed to melt 0.01kg of ice at 0°C?
Ans: 3360J
- How much heat energy is needed to change 0.2kg of ice at 0°C into steam at 100°C?
Ans: 601,200J
- An electric heater marked 225,000W keeps water boiling at 100°C. What mass of water evaporates in a second?
Ans: 0.1kg
- An electric heater was used to heat 2kg of water from 20°C to 50°C in 25 minutes. If the voltage across the heater was 24V, what was the current through the heater?
Ans: 7.0A
- 5kg of ice cubes are removed from the freezing compartment of a refrigerator into a home freezer. The refrigerator's freezing compartment is kept at -40°C the home freezer is kept at -17°C. How much heat does the freezer's cooling system remove from the ice cubes?
Ans: 241,500J
- What is the heat capacity of 5.5kg of aluminium?
Ans: 4,840JK⁻¹

GAS LAWS

Gas laws describe the behavior of gases when subjected to physical factors such as pressure and temperature.

These laws express the relationships between pressure (P), volume (V) and temperature (T) of a fixed mass of a gas.

There are three gas laws namely;

- Boyle's law.
- Pressure law.
- Charles' law.

Boyle's law:

It states that the volume of a fixed mass of a gas is inversely proportional to its pressure at constant temperature.

$$\begin{aligned} \text{Pressure} &\propto \frac{1}{\text{Volume}} \\ P &\propto \frac{1}{V} \\ P &= K \frac{1}{V} \\ PV &= K \end{aligned}$$

Where K is constant of proportionality

If the volume of gas changes from V_1 to V_2 and its pressure changes from P_1 to P_2 .

Then,
$$P_1V_1 = P_2V_2$$

Where P_1 – initial pressure

P_2 – final pressure

V_1 – initial volume

V_2 – final volume

Examples:

1. The volume of a fixed mass of a gas at constant temperature is 250cm^3 when the pressure is 720mmHg. Find the pressure when the volume is increased to 600cm^3 .

$$P_1 = 720\text{mmHg}, V_1 = 250\text{cm}^3, P_2 = ?, V_2 = 600\text{cm}^3$$

$$P_1V_1 = P_2V_2$$

$$720 \times 250 = P_2 \times 600$$

$$\frac{720 \times 250}{600} = P_2$$

$$P_2 = 300\text{mmHg}$$

SSEKWE ROBERT

2. The volume of a fixed mass of a gas at constant temperature is $2.0 \times 10^{-5} \text{ m}^3$ when the pressure is $7.2 \times 10^6 \text{ Pa}$, find the pressure when the volume is increased to $6.0 \times 10^{-4} \text{ m}^3$.

$$\begin{aligned}
 P_1 &= 7.2 \times 10^6 \text{ Pa}, V_1 = 2.0 \times 10^{-5} \text{ m}^3, P_2 = ?, V_2 = 6.0 \times 10^{-4} \text{ m}^3 \\
 P_1 V_1 &= P_2 V_2 \\
 7.2 \times 10^6 \times 2.0 \times 10^{-5} &= P_2 \times 6.0 \times 10^{-4} \\
 \frac{7.2 \times 10^6 \times 2.0 \times 10^{-5}}{6.0 \times 10^{-4}} &= P_2 \\
 P_2 &= 2.4 \times 10^4
 \end{aligned}$$

3. The volume of a fixed mass of a gas at constant temperature is 4 cm^3 when the pressure is 6 atmospheres, find the volume when the pressure is increased to 12 atmospheres.

$$\begin{aligned}
 P_1 &= 6 \text{ atmospheres}, V_1 = 4 \text{ cm}^3, P_2 = 12 \text{ atmospheres}, V_2 = ? \\
 P_1 V_1 &= P_2 V_2 \\
 6 \times 4 &= 12 \times V_2 \\
 \frac{6 \times 4}{12} &= V_2 \\
 V_2 &= 2 \text{ cm}^3
 \end{aligned}$$

4. The pressure of a fixed mass of a gas is 5 atmospheres when its volume is 200 cm^3 . Find the pressure when the volume is

- i) halved
ii) doubled

i)

$$\begin{aligned}
 P_1 &= 5 \text{ atmospheres}, V_1 = 200 \text{ cm}^3, P_2 = ? \\
 P_1 V_1 &= P_2 V_2 \\
 5 \times 200 &= P_2 \times \frac{200}{2} \\
 \frac{5 \times 200}{100} &= P_2 \\
 P_2 &= 10 \text{ atmospheres}
 \end{aligned}$$

ii)

$$\begin{aligned}
 P_1 V_1 &= P_2 V_2 \\
 5 \times 200 &= P_2 \times (2 \times 200) \\
 \frac{5 \times 200}{400} &= P_2 \\
 P_2 &= 2.5 \text{ atmospheres}
 \end{aligned}$$

Experiment to verify Boyle's law

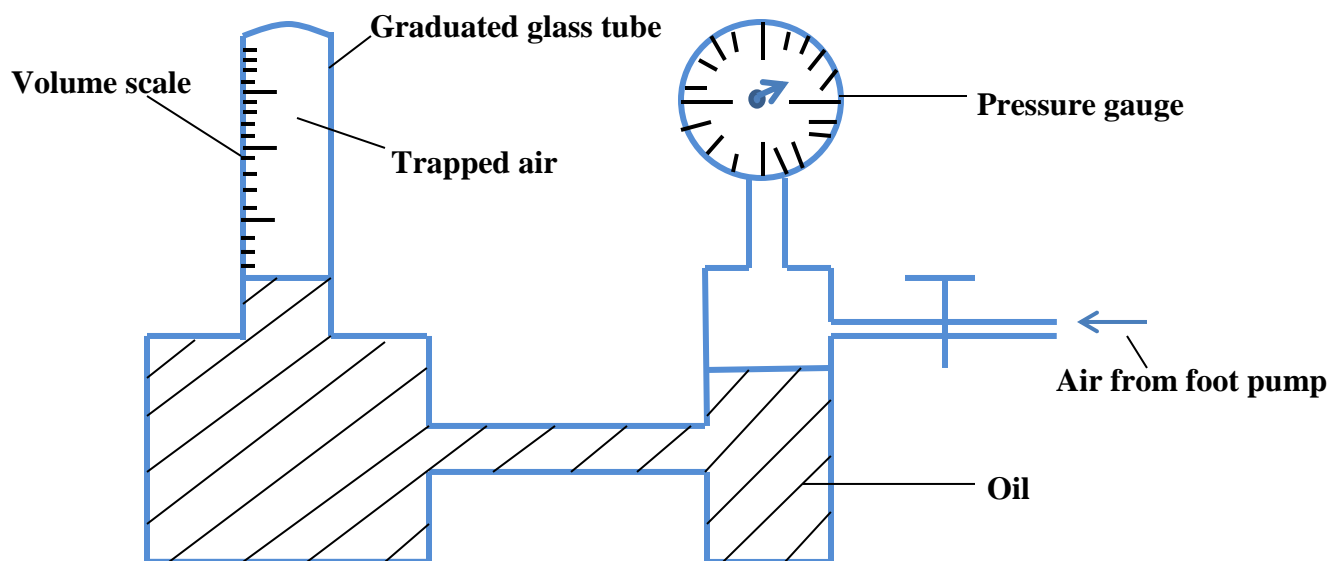

- Trap air above oil in the graduated glass tube.
- Read the initial volume, V and pressure, P of trapped air.
- Increase the pressure of trapped air by using a foot pump connected to a pressure gauge as shown above.
- Allow the air to cool to room temperature.
- Read and record the new values of V and P .
- Increase the pressure again to get different values of V and P .
- Record your results in a suitable table including values of $\frac{1}{V}$

P	V	$\frac{1}{V}$

- A graph of P against V is then plotted.



- A graph of P against $\frac{1}{V}$ is also plotted.

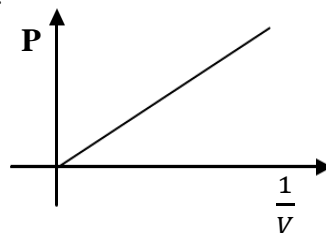

- From the above graphs it shows that pressure is inversely proportional to volume which is Boyle's law.

Pressure law (Gay Lussac law):

It states that the pressure of a fixed mass of a gas is directly proportional to its absolute temperature at constant volume.

Pressure \propto Absolute temperature

$$P \propto T$$

$$P = KT$$

$$\frac{P}{T} = K$$

Where ***K*** is constant of proportionality.

If the temperature of gas changes from T_1 to T_2 and its pressure changes from P_1 to P_2 .

Then,

$$\boxed{\frac{P_1}{T_1} = \frac{P_2}{T_2}}$$

Where T_1 – initial temperature

T_2 – final temperature

P_1 = initial pressure

P_2 = final pressure

Definition:

Absolute temperature is the temperature at which the volume of a gas reduces to zero.

Or **Absolute temperature** the temperature at which the molecules of a gas have the lowest kinetic energy

N.B: The temperature must always be in kelvins.

Examples:

1. The pressure of a fixed mass of a gas at 127°C is 600mmHg. Calculate its pressure at constant volume if the temperature reduces to 27°C .

$$P_1 = 600\text{mmHg}, P_2 = ?, \\ T_1 = 127^\circ\text{C} = 127 + 273 = 400\text{K}, \quad T_2 = 27^\circ\text{C} = 27 + 273 = 300\text{K}$$

$$\frac{P_1}{T_1} = \frac{P_2}{T_2}$$

$$\frac{600}{400} = \frac{P_2}{300}$$

$$P_2 = 450\text{mmHg}$$

2. The pressure of a gas is 75Nm^{-2} at -73°C . What is its pressure when a gas is heated up to 127°C .

$$P_1 = 75\text{Nm}^{-2}, P_2 = ?, T_1 = -73^\circ\text{C} = -73 + 273 = 200\text{K}, T_2 = 127^\circ\text{C} = 127 + 273 = 400\text{K}$$

$$\frac{P_1}{T_1} = \frac{P_2}{T_2}$$

$$\frac{75}{200} = \frac{P_2}{400}$$

$$P_2 = 150\text{Nm}^{-2}$$

3. A sealed flask contains a gas at a temperature of 27°C and a pressure of 90 kPa. If the temperature rises to 127°C. What will be the new pressure?

$$P_1 = 90\text{kPa} = 90 \times 1000 = 90,000\text{Pa}, P_2 = ?,$$

$$T_1 = 27^\circ\text{C} = 27 + 273 = 300\text{K}, \quad T_2 = 127^\circ\text{C} = 127 + 273 = 400\text{K}$$

$$\frac{P_1}{T_1} = \frac{P_2}{T_2}$$

$$\frac{90000}{300} = \frac{P_2}{400}$$

$$P_2 = 120,000\text{Pa}$$

Experiment to verify Pressure law

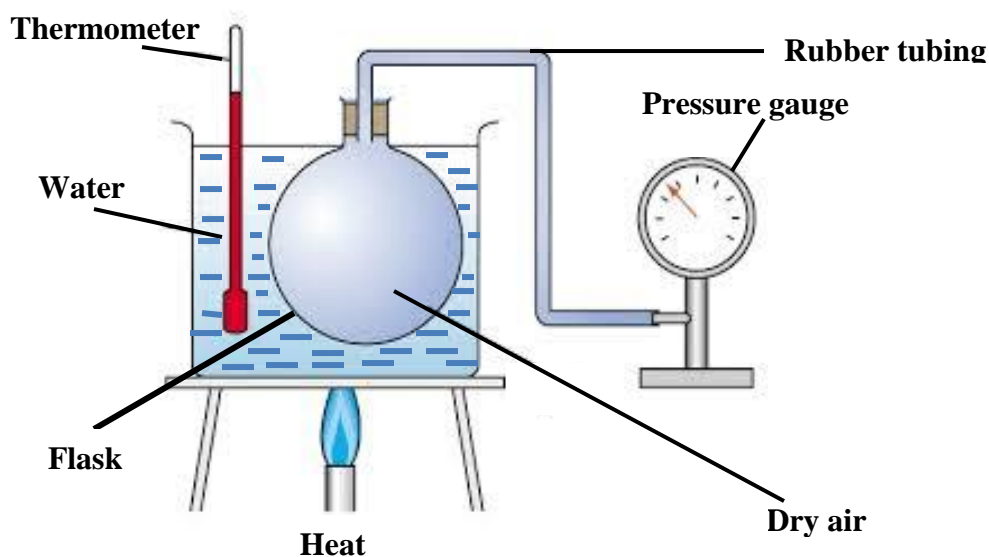

- The apparatus is set up as shown above.
- The flask containing dry air is placed in a metal can with water such that water is almost to the top of its neck.
- The can is heated from the bottom while stirring.
- Pressure, P is then recorded for different values of temperatures.
- The results are recorded in a suitable table

P	T(°C)	T(K)

- A graph of P against temperature is then plotted.

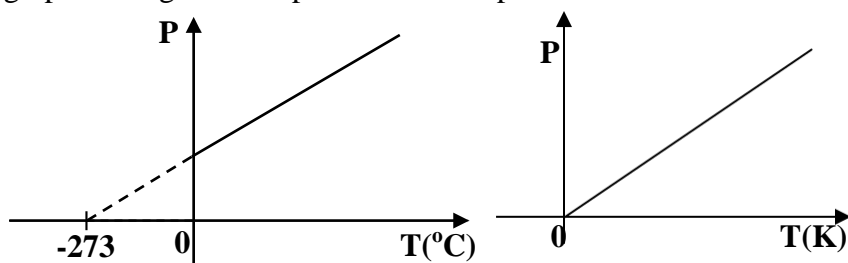

- From the above graphs it shows that pressure is directly proportional to the temperature which is pressure law.

NOTE: The temperature -273°C (0K) is called **absolute zero temperature**.

Charles' law:

It states that the volume of a fixed mass of a gas is directly proportional to its absolute temperature at constant pressure.

Volume \propto Absolute temperature

$$V \propto T$$

$$V = KT$$

$$\frac{V}{T} = K$$

*Where **K** is constant of proportionality.*

If the temperature of gas changes from T_1 to T_2 and its volume changes from V_1 to V_2 .

Then,
$$\boxed{\frac{V_1}{T_1} = \frac{V_2}{T_2}}$$

Where T_1 – initial temperature
 T_2 – final temperature
 V_1 = initial volume
 V_2 = final volume

Example:

1. The volume of a fixed mass of a gas at 127°C is 300cm^3 . Calculate its volume at constant pressure if the temperature reduces to 27°C .

$$\frac{V_1}{T_1} = \frac{V_2}{T_2}$$

$$\frac{300}{(127 + 273)} = \frac{V_2}{(27 + 273)} \rightarrow \frac{300}{400} = \frac{V_2}{300}$$

$$V_2 = 225\text{cm}^3$$

2. The volume of a fixed mass of a gas at 17°C is $5.0 \times 10^{-4} \text{m}^3$. Calculate its temperature at constant pressure if the volume reduces to $2.0 \times 10^{-4} \text{m}^3$

$$V_1 = 5.0 \times 10^{-4} \text{m}^3, V_2 = 2.0 \times 10^{-4} \text{m}^3,$$

$$T_1 = 17^{\circ}\text{C} = 17 + 273 = 290\text{K}, \quad T_2 = ?$$

$$\frac{V_1}{T_1} = \frac{V_2}{T_2}$$

$$\frac{5.0 \times 10^{-4}}{290} = \frac{2.0 \times 10^{-4}}{T_2}$$

$$\frac{2 \times 290}{5} = T_2$$

$$T_2 = 116\text{K}$$

3. The volume of a fixed mass of a gas at 27°C is 400cm^3 . Calculate its volume at constant pressure if the temperature reduces to -123°C .

$$V_1 = 400 \text{cm}^3, V_2 = ?,$$

$$T_1 = 27^{\circ}\text{C} = 27 + 273 = 300\text{K}, \quad T_2 = -123 + 273 = 150\text{K}$$

$$\frac{V_1}{T_1} = \frac{V_2}{T_2}$$

$$\frac{400}{300} = \frac{V_2}{150}$$

$$V_2 = 200 \text{cm}^3$$

4. The temperature of a fixed mass of a gas is 27°C . If the volume is halved, find its new temperature.

$$V_1 = V, \quad V_2 = \frac{V}{2},$$

$$T_1 = 27^{\circ}\text{C} = 27 + 273 = 300\text{K}, \quad T_2 = ?$$

$$\frac{V_1}{T_1} = \frac{V_2}{T_2}$$

$$\frac{V}{300} = \frac{\frac{V}{2}}{T_2}$$

$$\frac{V}{300} = \frac{V}{2T_2}$$

$$T_2 = \frac{300}{2}$$

$$T_2 = 150\text{K}$$

Experiment to verify Charles' law:

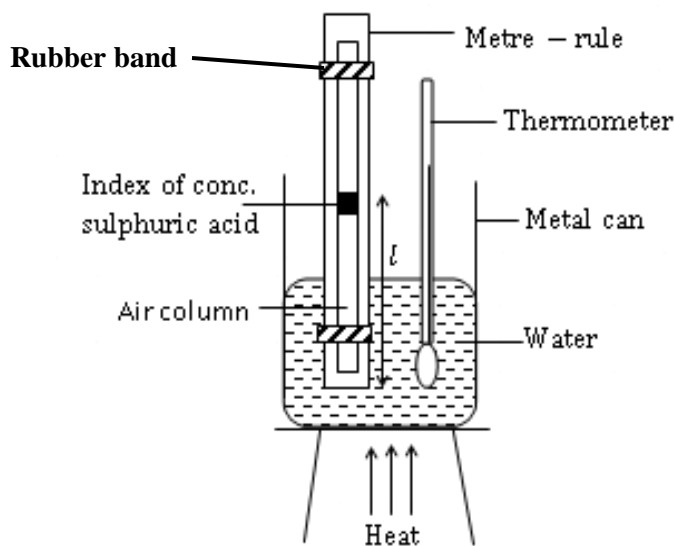

- Trap dry air using the index of concentrated sulphuric acid in a capillary tube.
- Tie the tube on the metre rule using a rubber band.
- Place the tied tube in a metal can containing water.
- Heat the water slowly while stirring gently.
- Read and record the length, L of the trapped air column and the temperature, T from the thermometer.
- Repeat procedures to obtain other values of L for different temperature values.
- Record the results in a suitable table.

$L(\text{cm})$	$T(^{\circ}\text{C})$	V

But L is proportional to volume, V so $V=L$

- Plot a graph of volume V against temperature T .

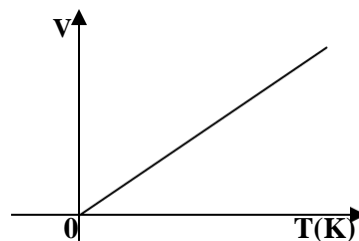
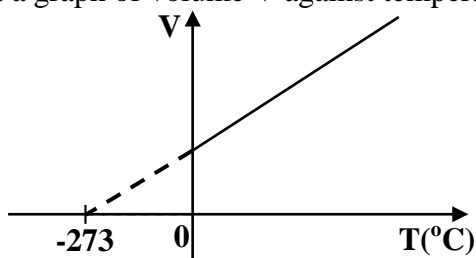

- From the above graphs it shows that volume is directly proportional to the absolute temperature which is Charles's law.

Equation of state for an ideal gas:

This is sometimes referred to as ideal gas equation. It combines the three gas laws. Combining the three gas laws, we get;

$$\frac{PV}{T} = K$$

Therefore if the volume of the gas changes from V_1 to V_2 , its pressure changes from P_1 to P_2 and its temperature from T_1 to T_2

$$\text{Then, } \frac{P_1 V_1}{T_1} = \frac{P_2 V_2}{T_2}$$

NOTE:

At standard temperature and pressure (s.t.p)

- Standard absolute temperature = **273K**
- Standard pressure = **76cmHg or 760mmHg or $1.01 \times 10^5 \text{Pa}$**

Examples:

1. In an experiment 500cm^3 of a gas was collected at a temperature of 97°C and a pressure of $3.7 \times 10^6 \text{Pa}$. Find the volume of the gas if the pressure changes to $6.0 \times 10^6 \text{Pa}$ at a temperature of 27°C .

$$\begin{aligned}
 P_1 &= 3.7 \times 10^6 \text{Pa}, P_2 = 6.0 \times 10^6 \text{Pa}, V_1 = 500\text{cm}^3, V_2 = ? \\
 T_1 &= 97^\circ\text{C} = 97 + 273 = 370\text{K}, \quad T_2 = 27^\circ\text{C} = 27 + 273 = 300\text{K} \\
 \frac{P_1 V_1}{T_1} &= \frac{P_2 V_2}{T_2} \\
 \frac{3.7 \times 10^6 \times 500}{370} &= \frac{6.0 \times 10^6 \times V_2}{300} \\
 V_2 &= \frac{3.7 \times 300 \times 500}{370 \times 6} \\
 V_2 &= 250\text{cm}^3
 \end{aligned}$$

2. A bicycle pump contains 50cm^3 of air at 17°C and a pressure of 1 atmosphere. Find the pressure when it is compressed to 10cm^3 and its temperature rises to 27°C .

$$\begin{aligned}
 P_1 &= 1 \text{ atm}, P_2 = ?, V_1 = 50\text{cm}^3, V_2 = 10\text{cm}^3? \\
 T_1 &= 17^\circ\text{C} = 17 + 273 = 290\text{K}, \quad T_2 = 27^\circ\text{C} = 27 + 273 = 300\text{K} \\
 \frac{P_1 V_1}{T_1} &= \frac{P_2 V_2}{T_2} \\
 \frac{1 \times 50}{290} &= \frac{P_2 \times 10}{300} \\
 P_2 &= \frac{50 \times 300}{290 \times 10} \\
 P_2 &= 5.17 \text{ atm}
 \end{aligned}$$

3. In an experiment 58cm^3 of a gas was collected at a temperature of 17°C and a pressure of 8.0×10^4 Pa. Find the volume the gas at s.t.p.

$$P_1 = 8.0 \times 10^4 \text{ Pa}, \quad \text{At s. t. p.}, P_2 = 1.01 \times 10^5 \text{ Pa}, V_1 = 58\text{cm}^3, V_2 = ?$$

$$T_1 = 17^\circ\text{C} = 17 + 273 = 290\text{K}, \quad \text{At stp}, T_2 = 273\text{K}$$

$$\frac{P_1 V_1}{T_1} = \frac{P_2 V_2}{T_2}$$

$$\frac{8.0 \times 10^4 \times 58}{290} = \frac{1.01 \times 10^5 \times V_2}{273}$$

$$V_2 = \frac{8 \times 273 \times 58}{290 \times 1.01 \times 10}$$

$$V_2 = 43.25\text{cm}^3$$

4. 240cm^3 of oxygen gas was collected when a temperature is 20°C at a pressure of 50cmHg . Calculate its volume at s.t.p.

$$P_1 = 50\text{cmHg}, T_1 = 20^\circ\text{C} = 20 + 273 = 293\text{K}, V_1 = 240\text{cm}^3,$$

$$\text{At s. t. p.}, \quad P_2 = 76\text{cmHg}, T_2 = 273\text{K}, V_2 = ?$$

$$\frac{P_1 V_1}{T_1} = \frac{P_2 V_2}{T_2}$$

$$\frac{50 \times 240}{293} = \frac{76 \times V_2}{273}$$

$$V_2 = \frac{50 \times 240 \times 273}{293 \times 76}$$

$$V_2 = 147.12\text{cm}^3$$

5. The volume of hydrogen at 273°C is 10cm^3 at a pressure of 152cmHg . What is its volume at s.t.p.

$$P_1 = 152\text{cmHg}, T_1 = 273^\circ\text{C} = 273 + 273 = 546\text{K}, V_1 = 10\text{cm}^3,$$

$$\text{At s. t. p.}, \quad P_2 = 76\text{cmHg}, T_2 = 273\text{K}, V_2 = ?$$

$$\frac{P_1 V_1}{T_1} = \frac{P_2 V_2}{T_2}$$

$$\frac{152 \times 10}{546} = \frac{76 \times V_2}{273}$$

$$V_2 = \frac{152 \times 10 \times 273}{546 \times 76}$$

$$V_2 = 10\text{cm}^3$$

Kinetic theory of Gas laws:

Recall; Kinetic theory of matter states that matter is made up of small particles called molecules that are in a continuous random motion and possess energy.

Question: Explain what causes gas pressure.

Increase in temperature, increases the speed of molecules and hence with the walls of the container thus creating pressure.

N.B: This explains why the pressure of a car tyre increases on a hot day.

Boyle's law:

For a fixed mass of a gas;

When the volume of the fixed mass of a gas is reduced at constant temperature the speed of the gas molecules increases hence the rate of collision with the walls of the container increases thus the pressure of the gas increases.

However increasing the volume of a gas reduces the pressure since the speed of the molecules of the gas reduces hence reducing on the rate of collision with the walls of the container.

Charles' law:

For a fixed mass of a gas;

When the temperature of the fixed mass of a gas is increased at constant pressure, the speed of the molecules of a gas increases and the rate of collision with the walls of a container increases thus increasing the volume of gas.

Pressure law:

For a fixed mass of a gas;

When the temperature of the fixed mass of a gas is increased at constant volume, the speed of the molecules of a gas increases and the rate of collision with the walls of a container increases hence the pressure of the gas increases.

VAPOURS

Vapour is the gaseous state of a substance below its critical temperature.

Critical temperature is the minimum temperature above which the gas cannot be changed back to a liquid.

There are two types of vapours namely;

- Saturated vapour
- Unsaturated vapour

SATURATED VAPOUR

This is the vapour that is in dynamic equilibrium with its own liquid.
i.e. *rate of evaporation = rate of condensation*

Saturated vapour pressure:

This is the pressure exerted by a vapour that is in dynamic equilibrium with its own liquid.

Explanation of occurrence of saturated vapour pressure (s.v.p) using kinetic theory

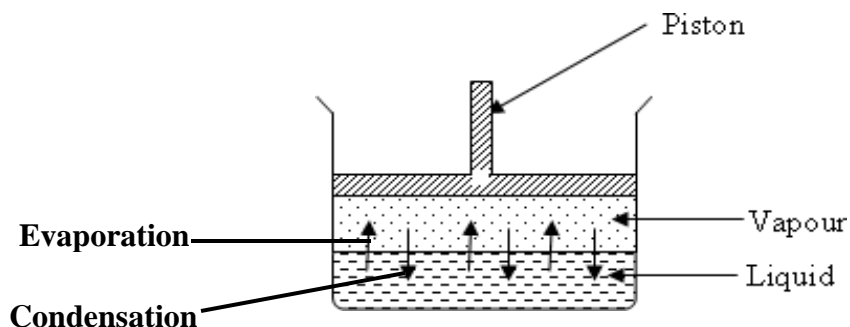

Consider a liquid enclosed in a container with a piston.

When a liquid in a closed container is heated, some of the liquid molecules get enough kinetic energy and break the intermolecular forces and escape from the surface of the liquid and occupy the space just above it and become vapour molecules. This process is called evaporation.

These vapour molecules collide with the walls of the container hence creating vapour pressure.

When these molecules bounce off from the walls of the container, they strike the liquid surface and re-enter the liquid. This process is called condensation.

A state of dynamic equilibrium is attained i.e. (rate of evaporation = rate of condensation) and this point, vapour is said to be saturated and exerting saturated vapour pressure.

Definition: Vapour pressure is the pressure exerted on the walls of the container by the vapour molecules.

NOTE:

Gas laws only apply to a fixed/constant mass of a gas.

Therefore, saturated vapours do not obey ideal gas laws because their masses change due to condensation or evaporation as the conditions change.

It should be noted that saturated vapour occurs for a very short time and at a constant temperature (boiling point).

UNSATURATED VAPOUR

This is the vapour that is not in dynamic equilibrium with its own liquid.
i.e. rate of evaporation \neq rate of condensation

Unsaturated vapour pressure:

This is the pressure exerted by a vapour that is not in dynamic equilibrium with its own liquid.

Differences between saturated vapour and unsaturated vapour

Saturated vapour	Unsaturated vapour
<ul style="list-style-type: none">• It doesn't obey gas laws.• It is the vapour in dynamic equilibrium with its own liquid.• Exists at a fixed temperature.	<ul style="list-style-type: none">• It obeys gas laws.• It is the vapour that is not in dynamic equilibrium with its own liquid.• Exists at any temperature.

Other terms;

Super saturated vapour:

This is the vapour whose rate of evaporation is greater than the rate of evaporation.

Ideal gas:

This is a gas whose intermolecular forces are negligible.

Real gas:

This is a gas whose intermolecular forces are not negligible.

Dew point:

This is the temperature at which atmospheric air is saturated with water vapour.

OR

This is the temperature at which water vapour condenses to liquid water (dew)

Note:

Fog or cloudy film forms on windscreens of cars because the dew point of water vapour has been exceeded.

EVAPORATION:

This is the process by which a liquid changes into gas (vapour).

OR

This is the escape of molecules of a liquid from its surface.

Evaporation takes place only at the surface of the liquid.

It takes place at all temperatures but it is greatest when the liquid is at its boiling point.

Explanation of evaporation according to kinetic theory:

(How evaporation causes cooling)

According to kinetic theory, molecules of a liquid are in a state of continuous random motion and their speed depend on the temperature of the liquid.

Faster moving molecules with the most kinetic energy reach the liquid surface and weaken the intermolecular forces of attraction and then escape from the surface of liquid causing evaporation.

The slow moving molecules with the lowest kinetic energy remain in the liquid thus cooling the liquid.

Recall: Temperature decreases with decrease in speed of molecules. Since some molecules have low speeds, so they are cold.

Applications of cooling as a result of evaporation:

- Panting of dogs.
- Making of ice by evaporation of a volatile liquid.
- Refrigerators.

Experiment to make ice by evaporation of a volatile liquid:

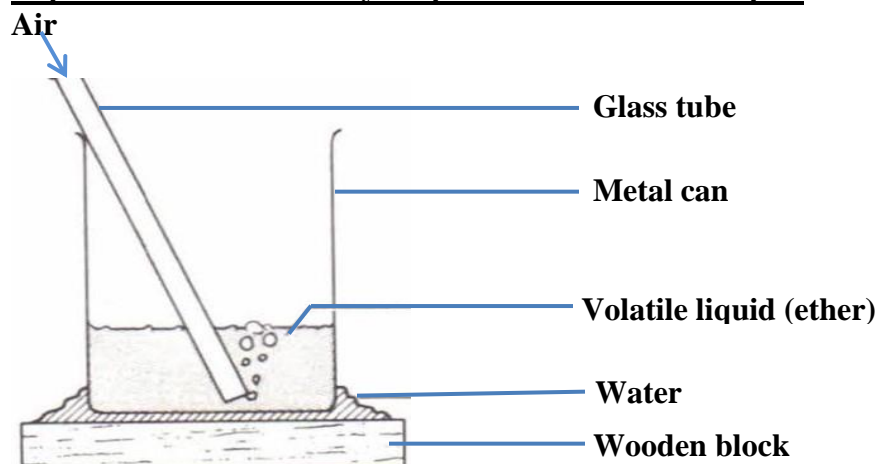

Procedures:

- Place a metal can filled with ether (volatile liquid) on a film of water on top of a wooden block.
- Blow air through the glass tube.

Observation:

- It is observed that the water under the can turns into ice i.e. it freezes.

SSEKWE ROBERT

Explanation:

Ether will evaporate when it gets necessary heat from water and blowing in air increases the rate of evaporation.

Since water is supplying heat to ether, it loses heat thus its temperature decreases hence water freezes to ice.

Definition:

Volatile liquid is a liquid with a low boiling point.

Factors that affect the rate of evaporation:

Rate of evaporation indicates the number of molecules that escape from liquid surface per second.

The following factors affect the rate of evaporation;

(i) Surface area:

Increasing the surface area increases the rate of evaporation because a large surface exposes many energetic molecules to escape while small surface exposes fewer molecules to escape.

- This explains why a plate cools porridge faster than a cup since the plate is wider than the cup.

(ii) Temperature:

Increasing temperature increases the rate of evaporation and decreasing the temperature decreases the rate of evaporation. At high temperature, more molecules will move faster to escape from the liquid surface but at low temperature fewer molecules move faster to escape from the liquid surface.

(iii) Wind (air currents):

The rate of evaporation increases if there is too much wind/air blowing because wind blows away molecules which have already escaped from the liquid so they can't return back to the liquid.

This explains why a person can cool porridge while blowing air through it.

(iv) Pressure:

Reducing pressure of air above the liquid surface (atmospheric pressure) increases the rate of evaporation since low pressure is exerted on the liquid surface.

(v) Intermolecular forces of a liquid:

The stronger the intermolecular forces, the slower the rate of evaporation since molecules will need much heat to break these forces.

REFRIGERATOR:

This is a cooling device which transfers heat from objects in it to the surrounding.

It is used in preservation of;

- Food in homes and supermarkets
- Blood in hospitals
- Medicines in hospitals and pharmaceuticals.

In a refrigerator, heat is taken in at one point and given out at another point by a volatile liquid or refrigerant.

HOW A REFRIGERATOR WORKS

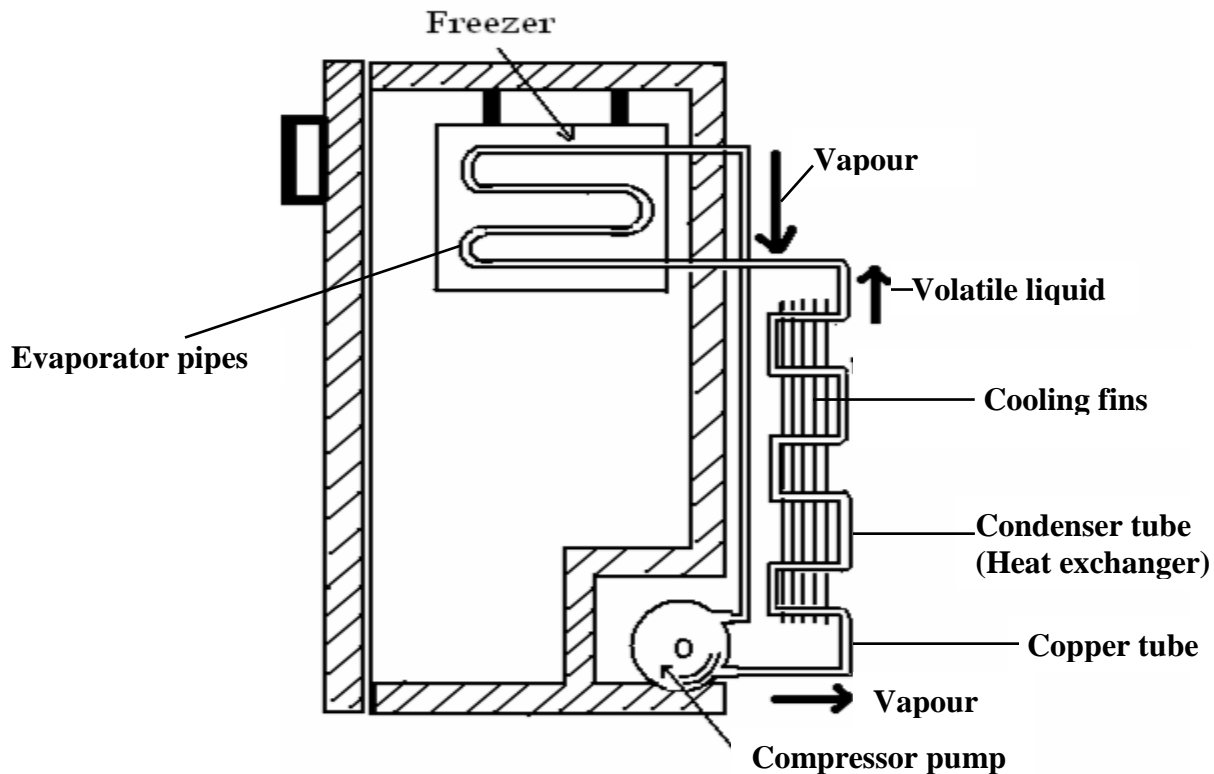

Mode of operation:

- The copper tube contains a volatile liquid which enters the evaporator pipes in the freezer.
- The volatile liquid gets latent heat from the refrigerator contents thus evaporating to vapour.
- This causes cooling of the contents since they lose heat.
- The vapour formed is compressed into the condenser tube and turns into a liquid thus giving out latent heat.
- The heat given out is lost to the surrounding through the cooling fins by convection and radiation.
- The liquid returns to the freezer and the process continues.

FUNCTIONS OF THE PARTS:

(a) Compressor pump:

This removes the vapour formed in the freezer and forces the vapour to the condenser tube.

(b) Condenser tube (Heat exchanger):

This where vapour is turned into a liquid giving out latent heat of vaporization to the surrounding air.

(c) Cooling fins:

These are painted black so that they can give out heat to the surrounding air. Black colours are good emitters of heat.

(d) Evaporator pipe:

This absorbs heat from the refrigerator contents and gives it to the volatile liquid so as to evaporate.

BOILING:

Definition:

Boiling is a process which occurs when atmospheric pressure is equal to saturated vapour pressure.

OR

Boiling is a process by which a liquid changes to vapour at its boiling point. Boiling occurs at a fixed temperature called boiling point and it takes throughout the liquid. Boiling involves formation of bubbles.

Differences between boiling and evaporation

Boiling	Evaporation
<ul style="list-style-type: none">• It occurs at a fixed temperature.• It takes place throughout the liquid.• Doesn't cause cooling.• Involves formation of bubbles.	<ul style="list-style-type: none">• It occurs at any temperature.• It takes place at the liquid.• Causes cooling.• Doesn't involve formation of bubbles.

FACTORS THAT AFFECT BOILING POINT OF A LIQUID

(i) Pressure:

The lower the atmospheric pressure, the lower the boiling point (temperature needed to boil a liquid). But if pressure is increased, the boiling point also increases.

This is because if the atmospheric pressure is decreased, then the liquid will boil more easily since it will take less time for its saturated vapour pressure to equal to atmospheric pressure.

This explains why;

- Cooking takes longer at higher altitudes.
- In a pressure cooker, food cooks more quickly.
- During cooking we cover our saucepans.

(ii) Impurities:

Addition of impurities like salt raises the boiling point of a liquid.

Salts in a water will cause water molecules to be more attracted to the salts thus a higher temperature is required to break the forces of attraction between water molecules thus increasing the boiling point of water.

This explains local salt “**kisula**” is added to beans so as they boil easily.

QUESTION:

Why cooking takes a lot of time to boil at high altitudes.

This is because at high altitude, the atmospheric pressure is low therefore, the boiling point of water is also low. This causes water to boil faster before food is properly cooked.

Hence it takes a lot of time for saturated vapour pressure to equal to the atmospheric pressure.

PRESSURE COOKER:

Pressure cookers are useful in places where the atmospheric pressure is low e.g. at the top of a mountain because they raise the boiling point of a liquid thus reducing time for cooking.

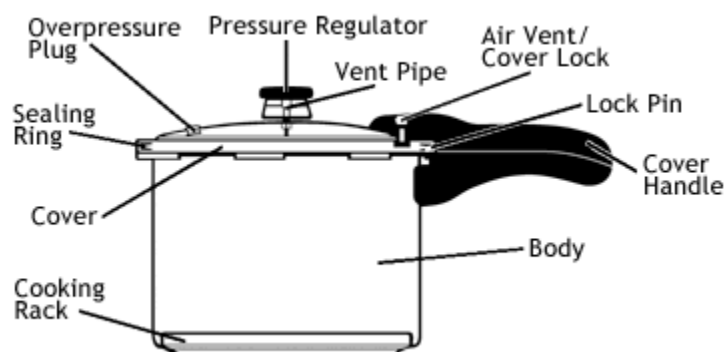

How a pressure cooker works.

- A pressure cooker has a lid (cover) that prevents steam from escaping.
- As water inside is heated, steam accumulates thus an increase in steam pressure causing the boiling point of water to rise above 100⁰C.

Thus food boils quickly thereby saving time and fuel.

FREEZING POINT AND MELTING POINT

Freezing is the process by which a liquid changes to a solid. Freezing occurs at constant temperature called freezing point.

Melting is the process by which a solid changes to a liquid. Melting occurs at a constant temperature.

Freezing point is a constant temperature at which a substance changes from liquid state to solid state.

Melting point is a constant temperature at which a substance changes from solid state to liquid state.

Factors that affect freezing and melting points of a substance.

(i) Pressure:

Increase in pressure lowers the melting/freezing point of a substance and vice versa

(ii) Impurities:

Addition of impurities lowers the melting/freezing points of a substance and vice versa.

- This explains why ice melts quickly when salt is sprinkled on it.

Effect of pressure on melting point of ice.

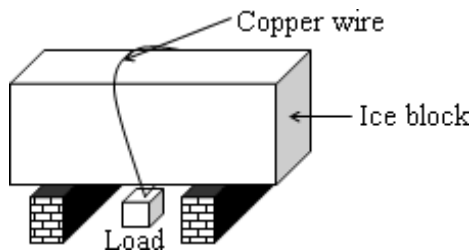

When pressure is increased on the ice by the copper wire;

- The copper wire passes through the ice block since increased pressure by the copper wire lowers the melting point of ice. So it melts easily at a low temperature.

HEAT ENGINE

A heat engine is a device used to convert heat energy to kinetic energy (mechanical energy).

Why engines are always less than 100% efficient.

- Because some of the energy is lost in overcoming friction since it has moving parts. This is friction is reduced by lubricating engine parts.
- Some heat is lost to surrounding due to conduction.
- Some energy is wasted in lifting useless loads like pistons.

PETROL ENGINE

It is also called the four stroke cycle engine.

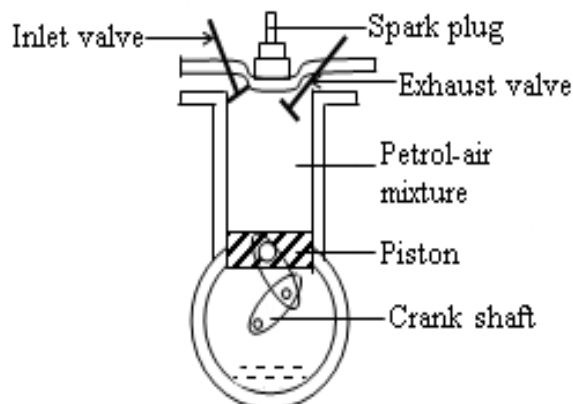

OPERATION OF A FOUR STROKE CYCLE ENGINE (PETROL ENGINE)

Intake (inlet) stroke:

- Piston moves down causing a vacuum.
- Inlet valve opens and the air –fuel mixture is forced into the cylinder from carburetor.
- Exhaust valve closes.

Compression stroke:

- Both valves close.
- The piston moves up compressing the air-fuel mixture.
- The fuel is ignited by a spark plug.

Power stroke:

- A spark jumps across the points of a spark plug and explodes the air-fuel mixture.
- Piston is forced to move down.

Exhaust stroke:

- The outlet valve opens pushing the exhaust gases out of the cylinder.

NOTE:

- The operation of a diesel engine is the same as that of a petrol engine.
- The diesel engine use diesel as a fuel yet petrol engines use petrol as a fuel.

Differences between diesel and petrol engines.

Diesel engine	Petrol engine
<ul style="list-style-type: none">• Uses diesel as a fuel.• No spark plug used.• Has a fuel injector instead of carburetor.• Produces a lot of smoke.• Uses less fuel.• They are expensive.• They are heavy	<ul style="list-style-type: none">• Uses petrol as a fuel.• Spark plug is used.• Has a carburetor instead of fuel injector.• Produce less smoke.• Uses a lot of fuel.• They are cheap.• They are lighter.

EXERCISE:

- 200litres of a gas at 0°C are kept under a pressure of 150kPa. If the temperature is raised to 273°C , its pressure is raised to 400kPa. Calculate its volume.
Ans: 150 litres
- The density of argon gas at 27°C is 0.27kgm^{-3} . A volume of 50m^3 of argon gas is kept under constant pressure at 27°C . What will be the density of argon if its temperature is raised to 51°C ?
Ans: 0.25kgm^{-3}
- The volume of a fixed mass of a gas at constant temperature is 150cm^3 when the pressure is 76cmHg. Calculate the volume when the pressure is 38cmHg.
Ans: 300cm^3
- The volume of a fixed mass of a gas at constant pressure is 400cm^3 at a temperature of 27°C . Calculate the volume when the temperature is raised to 78°C .
Ans: 468cm^3
- The pressure of a fixed mass of a gas at constant volume is 600mmHg at a temperature of 127°C . Calculate the pressure when the temperature falls to 27°C .
Ans: 450mmHg
- Air in a 2.5litre vessel at 127°C exerts a pressure of 3 atmospheres. Calculate the pressure that the same mass air would exert if contained in a 4litre vessel at -73°C
Ans: 0.9375atmospheres.
- State differences between boiling and evaporation
- Distinguish between saturated vapour and un-saturated vapour
- What are the factors that affect the rate of evaporation of a liquid and how
- Use the kinetic theory to explain effect of increasing temperature of the gas at constant pressure

EXAMINATION QUESTIONS:

- Define specific heat capacity
 - 0.05kg of water at 80°C is mixed with 0.06kg of water at 10°C contained in a vessel of heat capacity 28Jkg^{-1} . What is the final temperature of the mixture?
Ans: 400°C
 - Define specific latent heat of fusion
 - Describe a simple method to determine the specific latent heat of fusion of ice
 - When 0.005kg of ice at 0°C is added to 0.02kg of warm water at 30°C the final temperature attained is 8°C . Find the specific latent heat of fusion of ice.
Ans: $336,000\text{Jkg}^{-1}$
- State Boyle's law
 - With the aid of a labeled diagram describe the experiment to show the relationship between the volume and the temperature of a fixed mass of a gas at atmospheric pressure.
 - A cylinder with a movable piston contains 0.1m^3 of air at a temperature of 27°C . Calculate the volume of the gas if it is cooled to -33°C at constant pressure.
Ans: 0.08m^3

SSEKWE ROBERT

- c) Define the term specific heat capacity
- d) A copper block of mass 200g is heated to a temperature of 145°C and then dropped into a well lagged copper calorimeter of mass 250g which contains 300cm³ of water at 25°C
 - i) Calculate the maximum temperature attained by the water
 - ii) Sketch a graph to show the variation of temperature of water with time

Ans: i) 31.7°C

3. a) i) Define heat capacity of a substance
- ii) Describe an experiment to determine specific heat capacity of a substance by method of mixtures
 - iii) State the precautions necessary for accuracy during the experiment above
- b) A well lagged copper calorimeter of mass 85g contains 80g of water at 60°C. Dry ice at 0°C is added to the calorimeter and after stirring the mixture attains a steady temperature of 20 °C. Find the mass of ice added

Ans: 35.2°C

- c) i) Describe an expiration to show that evaporation produces cooling.
- ii) Explain why evaporation produces cooling.
- iii) State one application of cooling by evaporation.

4. a) i) What is a saturated vapour
- ii) Explain why the boiling point of a liquid depends on altitude.
- b) i) Define specific heat capacity.
- ii) Describe an experiment to determine the specific heat capacity of a solid
- c) A copper block of mass 250g is heated to a temperature of 145°C and then transferred to a cooper calorimeter of mass 250g which contains 250cm³ of water at 20°C
- i) Calculate the maximum temperature attained by water
 - ii) Sketch the graph to show the variation of temperature with time

Ans: i) 300C

- d) i) What is meant by the term temperature
- ii) Give two physical properties which change with temperature

5. a) Define the following terms as used in heat
- i) Specific heat capacity
 - ii) Latent heat of vaporization
- b) Describe an experiment to determine the specific heat capacity of a liquid
- c) Steam from boiling water is bubbled through 1.5kg of water at 20°C. After this process, the mass of water was found to be 1.54 kg. What is the new temperature of water?

Ans: 35.99°C

- d) State four ways in which heat losses can be minimized in a calorimetry experiment

6. a) Define specific latent heat of fusion
- b) Describe an experiment to determine the specific latent heat of fusion of ice
- c) A copper block of mass 300g is heated to a temperature of 245°C and then dropped into a well lagged copper calorimeter of mass 350g containing 400g of water at 35°C.

SSEKWE ROBERT

Calculate the maximum temperature attained by the water.

Ans: 43.3°C

- d) i) What is meant by absolute zero temperature
ii) A sealed flask contains gas at a temperature of 27°C and a pressure of 900Pa. if the temperature rises to 127°C. What will be the new pressure?

Ans: ii) 1200Pa

7. a) i) Define temperature.
ii) The fundamental interval of a mercury-in-glass thermometer is 192mm. Find the temperature in degrees Celsius when mercury thread is 67.2mm long
b) With the aid of a labeled diagram describe the experiment to show the relationship between the volume and the pressure a fixed mass of a gas at constant temperature.
c) A copper block of mass 150g is heated to a temperature of 95°C and then dropped into a well lagged copper calorimeter of mass 200g containing 250g of water at 15°C. Calculate the maximum temperature attained by the water.

Ans: 19.0°C

- d) State any two differences between boiling and evaporation
8. a) Define specific latent heat of vaporization
b) A calorimeter of mass 35g and specific heat capacity $840\text{Jkg}^{-1}\text{K}^{-1}$ contains 143g of water at 7°C. Dry steam at 100°C is bubbled through water in the calorimeter until the temperature of the water rises to 29°C. If the mass of steam which condenses is 5.6g,
i) Calculate heat gained by the water and calorimeter
ii) Obtain an expression for the heat lost by the steam in condensing at 100°C and in cooling to 29°C.
iii) Find the specific latent heat of vaporization of water

Ans: i) 13860J ii) $0.0056L_v + 1669.92$ iii) 2,176,800

- c) Explain in terms of molecules what is meant by a saturated vapour?
d) Describe briefly one application of vaporization
9. a) i) Describe the fixed points of a Celsius scale of temperature
ii) Give two advantages of mercury over alcohol as thermometric liquid
iii) Convert -200°C to Kelvin

Ans iii) 73°C

- b) Use the kinetic theory to explain the following
i) Cooling by evaporation
ii) Why the temperature of a gas contained in a cylinder increases when it is compressed
c) Explain briefly the transfer of thermal energy by conduction in metals
d) A battery of e.m.f 12V and internal resistance 1Ω is connected for 3minutes across a heating coil of resistance 11Ω immersed in a liquid of mass 0.2kg and specific heat capacity $2.0 \times 10^3\text{Jkg}^{-1}\text{K}^{-1}$. Find the rise in temperature of the liquid. State clearly any assumptions made.

Ans: 4.95°C

10. a) With the aid of a labeled diagram, describe the experiment to show the relationship between temperature and pressure a fixed mass of a gas at constant volume.

SSEKWE ROBERT

- b) A gas of volume 1000cm^3 at a pressure of 4.0×10^5 Pa and temperature of 17°C is heated to 89.5°C at constant pressure. Find the new volume of the gas.

Ans: 1250cm^3

- c) A balloon is filled with 50cm^3 of hydrogen and tied to the ground. The balloon alone and the container it carries have a mass of 2kg. If the densities of hydrogen and air are $9.0 \times 10^{-2}\text{kgm}^{-3}$ and 1.29kgm^{-3} respectively, how much load can the balloon lift when released

11. a) What is meant by conduction
b) Draw a labeled diagram of a thermos flask and explain how it is able to keep a liquid cold for a long time
c) With the aid of a diagram, describe how you would determine the upper fixed point of an un-calibrated thermometer
d) Explain the following observations;
i) A bare cement floor feels colder than a carpeted one
ii) A beam with a notch that is used for constructing a bridge lasts longer when the notch is on its top surface than when the notch is on its lower surface
12. a) Define the following terms
i) Specific heat capacity
ii) Specific latent heat of fusion

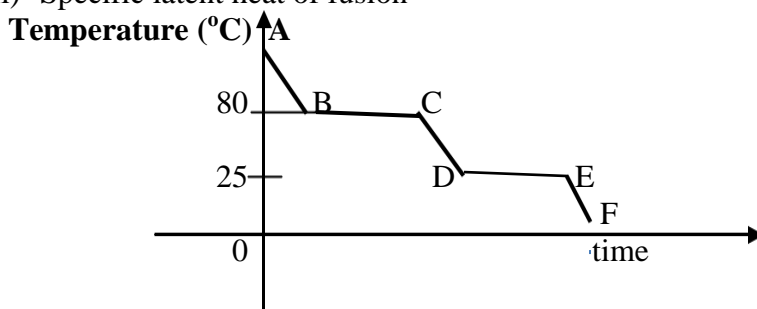

- b) The figure above shows a cooling curve of a liquid whose boiling point is 80°C and freezing point is 25°C .
i) Give the states over regions AB, BC, DE and EF
ii) What is happening over region BC?
iii) Use the kinetic theory to explain the differences in states over regions AB and EF
c) An iron rod of mass 0.8kg is pushed into an insulator solid substance through a distance of 2.3m against frictional force of 400N. The temperature of iron rises by 2.5°C . Calculate the specific heat capacity of iron

Ans: $460\text{Jkg}^{-1}\text{K}^{-1}$

- d) i) Explain why when water in a saucepan is heated, the level first falls and then rises after some time
ii) The length of mercury thread of un-calibrated thermometer is 10cm when the bulb is in pure melting ice and rises to 20cm in steam. What is the reading of the thermometer when the mercury thread is 18cm?

Ans: ii) 800°C

SSEKWE ROBERT

13. a) Define specific latent heat of vaporization
b) Describe an experiment to determine specific latent heat of vaporization of steam
c) A copper calorimeter of heat capacity 60Jkg^{-1} contains 0.5kg of water at 20°C . Dry steam at 100°C is passed into the water in the calorimeter until the temperature of the water and the container reaches 50°C . Calculate the mass of steam condensed

Ans: 4.61kg

- d) i) What is meant by saturated vapour pressure
ii) Explain what may happen when one is to cook food from a very high altitude
14. a) i) Define latent heat of fusion.
ii) Describe with the aid of a labeled diagram, an experiment to show the effect of increase in pressure on the melting point of ice
b) If the melting point of lead is 327°C , find the amount of heat required to melt 200g of lead initially at 27°C given that specific latent heat of fusion of lead is $2.5 \times 10^6\text{Jkg}^{-1}$ and specific heat capacity of lead is $660\text{Jkg}^{-1}\text{K}^{-1}$.

Ans: 539,600J

- c) What is meant by the terms?
i) Temperature
ii) Heat
- d) State two physical properties which change with temperature.
15. a) Describe an experiment to determine the specific latent heat of fusion of ice
b) i) 2kg of ice initially at -10°C is heated until it changes to steam at 100°C
ii) Sketch the graph to show how temperature changes with time
iii) Calculate the energy required at each end of the graph

Ans: 42,000J 672,000J 840,000J 4,500,000J

16. a) Differentiate between conduction and convection
b) Describe an experiment which can be performed to show convection in a liquid
c) i) Draw a labeled diagram of a vacuum flask
ii) Explain how a vacuum flask minimizes heat losses
d) Why is a car radiator made of fins and painted black

17. a) State the kinetic theory of matter
b) i) State the law of volume and temperature
ii) The volume of a fixed mass of a gas at a given pressure is 1.5m^3 at 300K . at what temperature will the volume of the gas be at the same pressure
c) Describe an experiment to determine the fixed points of a thermometer
d) i) Mention any three reasons for not using water as a thermometric liquid
iii) When a Celsius thermometer is in a boiling liquid, the mercury thread rises above the lower fixed point by 19.5cm . Find the temperature of boiling liquid if the fundamental interval is 25cm .

Ans: 78°C

18. a) What is meant by latent heat of vaporation
b) With the aid of a labeled diagram describe how a refrigerator works

SSEKWE ROBERT

- c) The cooling system of a refrigerator extracts 0.7kW of heat. How long will it take to convert 500g of water at 20°C into ice?

Ans: 300s

- d) Explain how evaporation takes place

19. a) What is meant by conduction

- b) Draw a labeled diagram of a vacuum flask and explain how it is able to keep a liquid hot a long time
- c) With the aid of a labeled diagram describe an experiment to determine the upper fixed points of an un-calibrated thermometer
- d) Explain the following observation a bare cement floor feels colder than a carpeted one

20. a) i) Define latent of fusion

- ii) Describe with the aid of a labeled diagram, an experiment to show the effect of increase in pressure on the melting point of ice

b) What is meant by the terms?

i) Temperature

ii) Heat

- c) The fundamental interval of mercury in glass is 192mm. find the temperature in degrees Celsius when the mercury thread is 67.2mm below the upper fixed point.

Ans: 65°C

- d) State two physical properties which change with temperature

Experiment 18

A small mass is attached to a length of thread as shown in Figure 18. This is referred to as the plumbline.

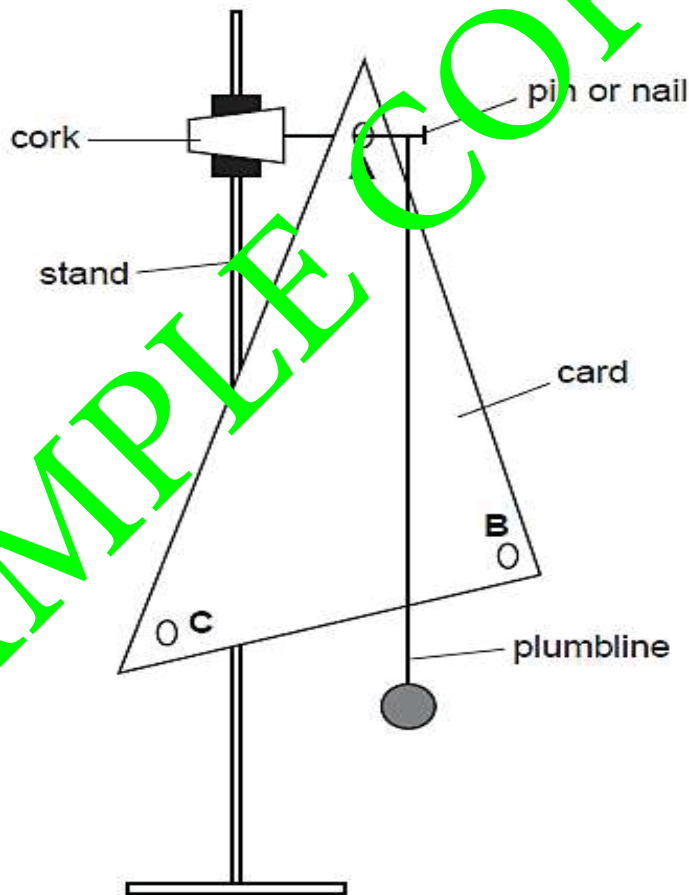

Fig. 18

- (a) Suggest a suitable title for this experiment.

.....
.....

- (b) Carry out the following instructions referring to Figure 18.

- (c) Measure and record the lengths of the three sides of the triangular sheet of card.

length 1 =

length 2 =

length 3 =

(01 mark)

- (d) (i) Hang the card on the nail through hole A.
(ii) Hang the plumbline from the nail so that it is close to the card but not touching it.
(iii) When the card and plumbline are still, make a small mark at the edge of the card where the plumbline crosses the edge.
(iv) Remove the card and draw a line from the mark to hole A.

Experiment 12

Imagine you are conducting an experiment to investigate the period of a pendulum. The apparatus is set up as described in the instructions, and you refer to Figure 12.1 and Figure 12.2. Follow the given steps to perform the experiment.

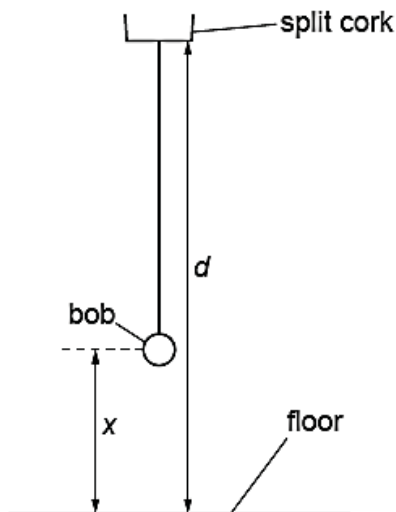

Fig. 12.1

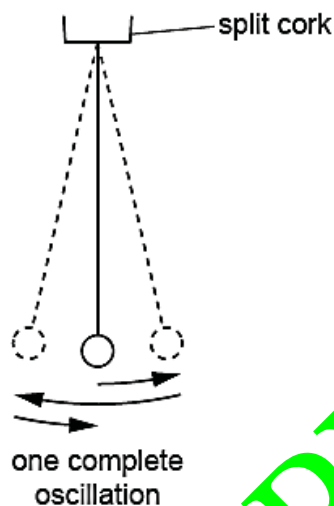

Fig. 12.2

- (a) Start by measuring the distance d between the bottom of the split cork and the floor.

$$d = \dots\dots\dots\text{cm} \quad (01 \text{ mark})$$

This distance d must remain constant throughout the experiment.

- (b) • Adjust the length of the pendulum until the distance x , measured from the centre of the bob to the floor, is 50.0 cm.
 • Displace the bob slightly and release it so that it swings. Figure 12.2 shows one complete oscillation of the pendulum.
 • Measure, and record in Table 12, the time t for 10 complete oscillations.
 • Calculate, and record in Table 12, the period T of the pendulum. The period is the time for one complete oscillation.
 • Calculate, and record in Table 12, T^2 . (02 marks)

Table 12

$x(\text{cm})$	$t(\text{s})$	$T(\text{s})$	$T^2(\text{s}^2)$
50.0			
45.0			
40.0			
35.0			
30.0			

- (c) From the experiment described above, identify:
- (i) The independent variable
 - (ii) The dependent variable
 - (iii) The constant variable
- (d) Repeat the procedure in (b) using $x = 45.0$ cm, 40.0 cm, 35.0 cm and 30.0 cm. (03 marks)
- (e) Plot a graph of T^2 (along the vertical axis) against x (along the horizontal axis). You do not need to start your axes at the origin (0,0). (04 marks)

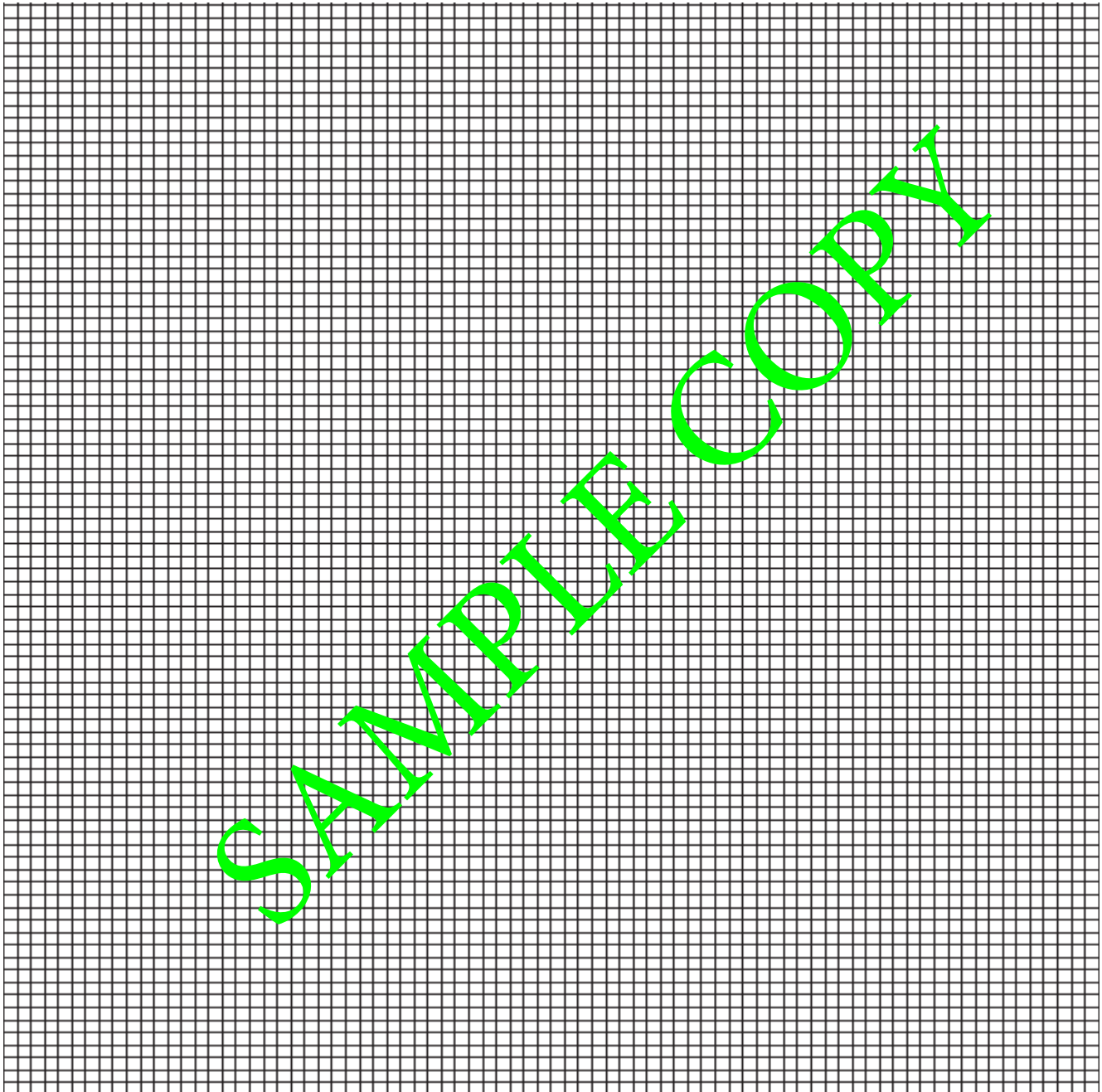

- (f) Explain why timing 10 oscillations gives a more accurate result for the period T than timing one oscillation. (01 mark)

- (i) Measure and record in Table 25 the angle of incidence i between the line AN and the normal. Measure, and record in the table, the angle of reflection r between the normal and the line passing through P₂ and P₃.

Table 25

<i>edge</i>	$i(^{\circ})$	$r(^{\circ})$
A		
B		

(03 marks)

- (j) Repeat the steps (e) – (i) but using edge **B** of the card instead of edge **A**.
- (k) In spite of carrying out this experiment with care, it is possible that the values of the angle of reflection r will not be exactly the same as the values obtained from theory. Suggest **two** possible causes of this inaccuracy.

1.

 2.

(02 marks)

Insert your ray-trace sheet opposite this page.

(05 marks)

Experiment 26

Concave mirrors curve inward and are thicker at the center than at the edges, causing light rays parallel to the optical axis to converge. These mirrors are employed in applications such as reflecting telescopes for gathering and focusing light in astronomy, and in cosmetic mirrors where their ability to produce enlarged and upright images is utilized for personal grooming. However, it is necessary to determine the focal length, f of a concave mirror before its use.

- (a) A concave mirror is placed in a holder and used to focus light from a window onto a screen. The screen is adjusted until a sharp image is formed on it.
- (i) Measure and record the distance d , between the screen and mirror.

$d = \dots\dots\dots$ (01 mark)

- (ii) Explain the meaning of distance . (01 mark)

.....

- (b) Arrange the apparatus as shown in figure 38. Adjust the distance, u , of the torch bulb from the mirror to 15cm. Close switch K . Adjust the position of the white screen, S_2 until a sharply focused image of the wire gauze appears on it. Open switch K .

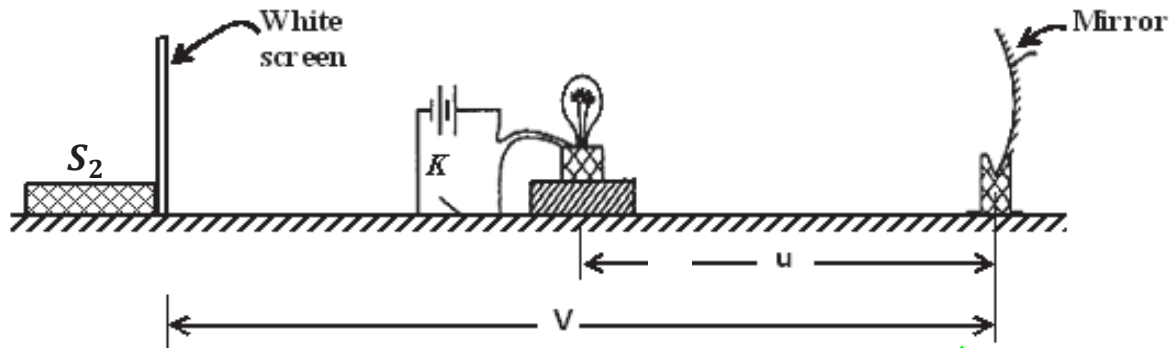

Fig. 38

- (c) Measure and record the distance, v of the screen S_2 from the mirror.

$v = \dots\dots\dots$ (01 mark)

- (d) Calculate the values of $y = V - d$ and $x = u - d$.

$y = \dots\dots\dots$ (01 mark)

$x = \dots\dots\dots$ (01 mark)

- (e) Repeat procedures (f) to (h) for values of $u = 35.0, 40.0, 45.0, 50.0$ and 55.0cm .

- (f) Tabulate your results including values of $\frac{1}{x}$.

Table 38

(06 marks)

- (g) From the experiment described above, identify:
- (i) The independent variable
 - (ii) The dependent variable
 - (iii) The constant variable

(h) Plot a graph of y against $\frac{1}{x}$. (06 marks)

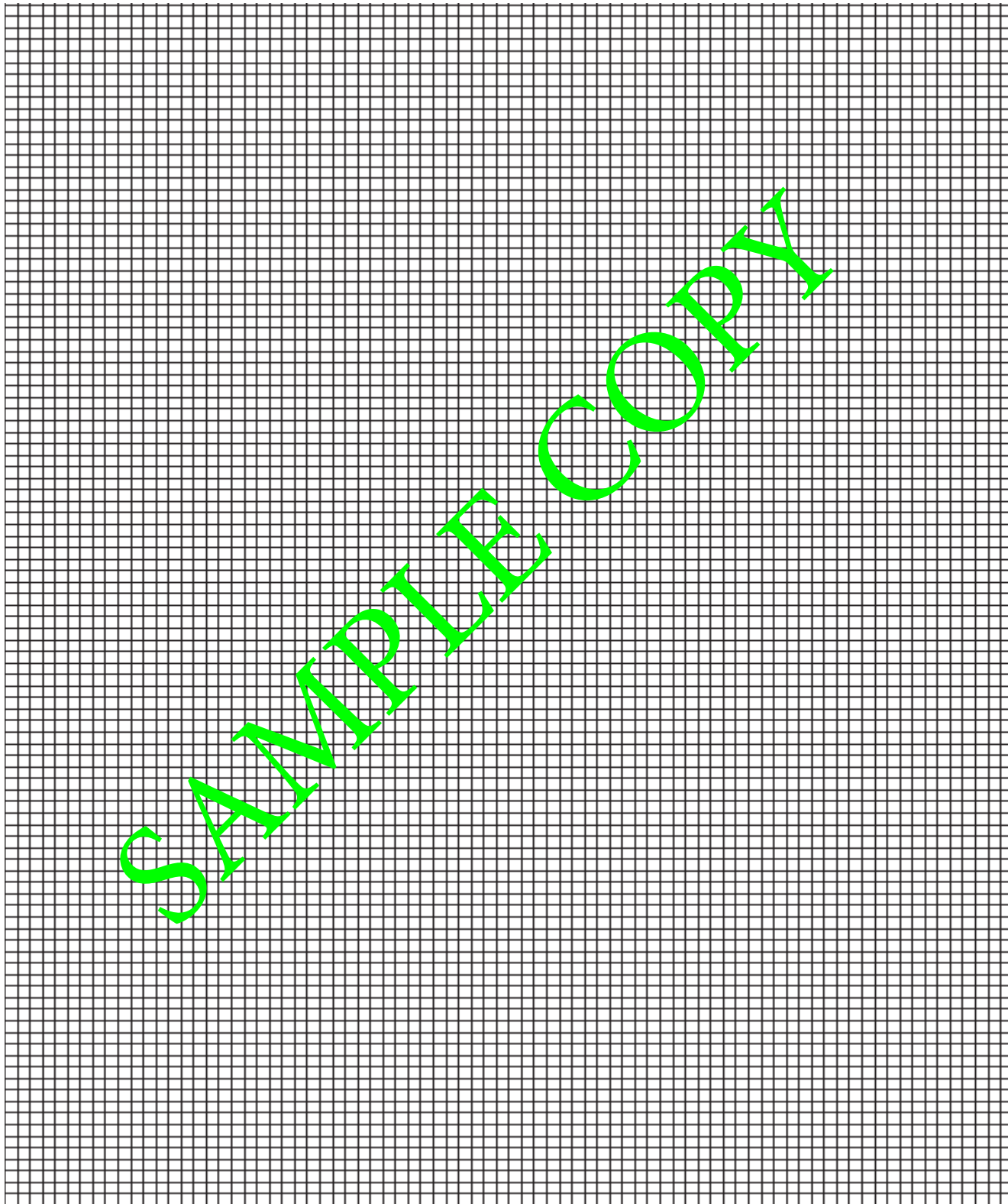

- (i) Determine the slope, S of the line of best fit. Show your working and indicate on the graph the values you use to calculate the gradient G .

$$S = \dots\dots\dots (02 \text{ marks})$$

- (j) Calculate the value of f_1 from $f_1 = \sqrt{S}$.

$$f_1 = \dots\dots\dots (02 \text{ marks})$$

- (k) Determine the value of the constant, f of the concave mirror using $f = \frac{1}{2}(f_1 + d)$

$$f = \dots\dots\dots (02 \text{ marks})$$

Experiment 27

This experimental investigation has two parts, (I) and (II).

PART I

A concave mirror is mounted in a mirror holder and a pin in cork is placed such that its pointed end lies along the axis of the mirror. The pin is moved towards and away from the mirror until it coincides with its image by no-parallax.

- (a) Suggest a suitable title for this experiment. (01 mark)

.....

- (b) State **one** suitable hypothesis that could be investigated. (01 mark)

.....

- (c) With the apparatus provided, set up this experiment. Measure and record the distance, N between the pin and the mirror.

$$N = \dots\dots\dots (01 \text{ mark})$$

- (ii) Calculate, the quantity, B from: $B = \frac{L}{S} \times \frac{N}{L}$

$f = \dots\dots\dots (02 \text{ marks})$

PART II

- (a) Set up a new arrangement of apparatus as shown in Figure 27. Place the mirror, wire gauze and bulb such that distance, x

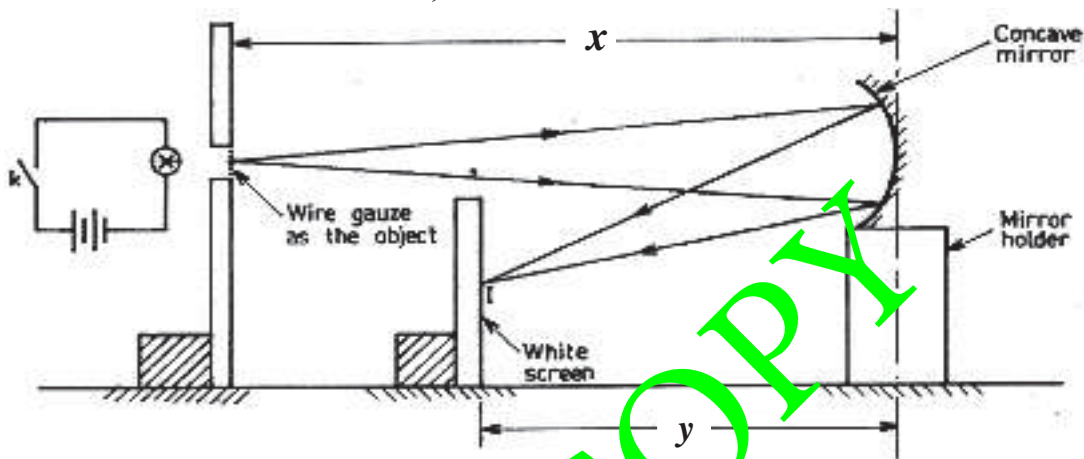

Fig. 27

Close switch, k and adjust the position of the screen until a clear image of the wire gauze is obtained on the screen.

- (i) Measure and record the distance, y between the mirror and screen.
 $y = \dots\dots\dots (01 \text{ mark})$

- (b) Repeat procedures (a) to (i) for $x = 2f$ and $x = f < x < 2f$

- (c) Tabulate your results including values of $\frac{u}{v}$ (06 marks)

SAMPLE COPY

.....

.....

.....

.....

.....

.....

.....

.....

.....

.....

.....

.....

.....

.....

.....

.....

.....

.....

(d) From the experiment you have just carried out, state; (04 marks)

(i) The aim of the experiment

T (ii) The independent variable

(ii) The dependent variable

(iii) The constant variable

(e) Plot a graph of $\frac{y}{x}$ against y . (06 marks)

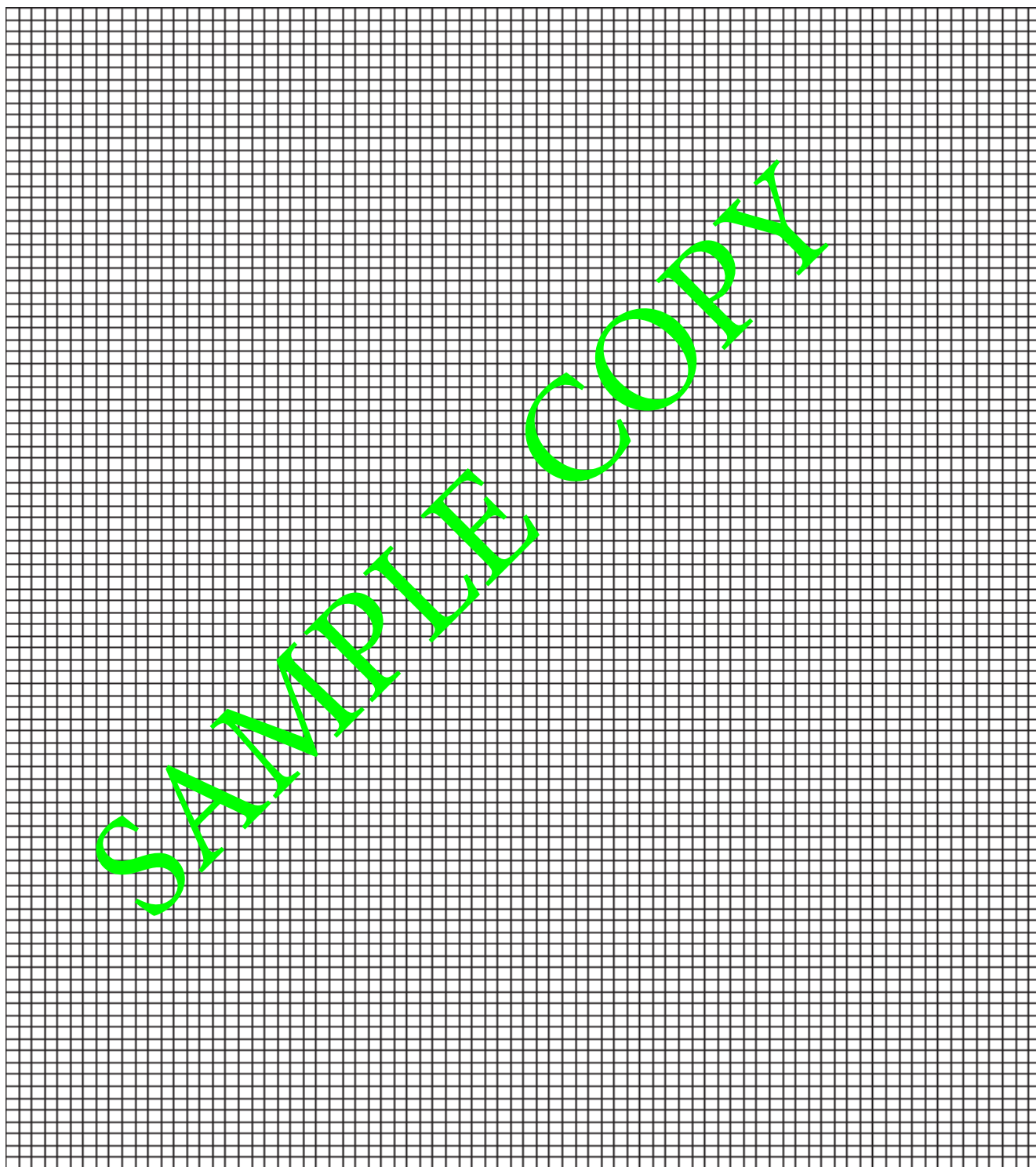

(g) The resistance R_W of the wire is calculated using the equation: $R_W = \frac{22}{N}$

where $N = \frac{V_S}{100G} - 1$

Use your value of V_S recorded in (b) and your value of G calculated in (f) to calculate R_W . Show your working.

$R_W = \dots\dots\dots\Omega$ (01 mark)

Experiment 48

In this experiment you will investigate the resistance of a light-emitting diode (LED).

You are provided with:

- a power supply
- a light-emitting diode
- 5 resistors of resistance 150Ω
- a switch
- connecting wires and crocodile clips.

The supervisor has set up the circuit shown in Figure 48.

The crocodile clip shown in the diagram in Figure 48 is a movable contact that can be attached at different points in the circuit.

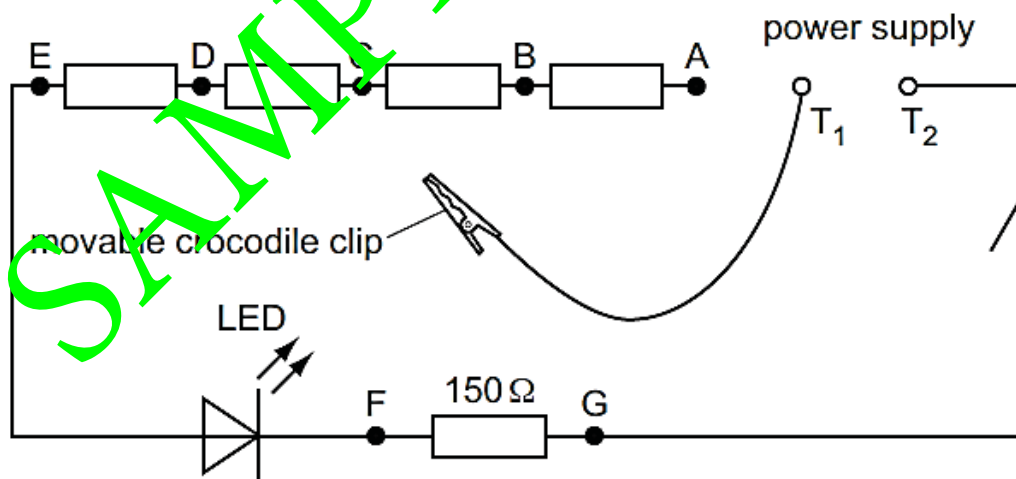

Fig. 48

You are also provided with a voltmeter and two additional connecting wires.

- (a) (i) Make sure that the movable crocodile clip and wire is not touching any other part of the circuit.

Connect the voltmeter between the terminals T_1 and T_2 of the power supply. Record the reading V_S on the voltmeter.

Disconnect the voltmeter from the power supply.

$$V_S = \dots\dots\dots V \text{ (01 mark)}$$

- (ii) Attach the movable crocodile clip to one of the wires either side of the crocodile clip labelled A.

Connect the voltmeter between F and G.

Close the switch.

Record the reading V on the voltmeter.

Open the switch.

$$V = \dots\dots\dots V \text{ (01 mark)}$$

- (iii) Using your answer from (a)(ii), calculate the current I_{LED} in the LED using the equation $I_{LED} = \frac{V}{150}$

$$I_{LED} = \dots\dots\dots A \text{ (01 mark)}$$

- (iv) The total number of resistors connected in series with the LED is n . When the movable crocodile clip is attached by A, the value of n is 5.

Using your answers from (a)(i) and (a)(ii), calculate the voltage V_{LED} across the LED using the equation

$$V_{LED} = V_S - nV.$$

$$V_{LED} = \dots\dots\dots A \text{ (01 mark)}$$

- (v) Using your answers from (a)(iii) and (a)(iv), calculate the resistance R_{LED} of the LED using the equation

$$R_{LED} = \frac{V_{LED}}{I_{LED}}$$

$$R_{LED} = \dots\dots\dots \Omega \text{ (01 mark)}$$

SAMPLE COPY

- (b) (i) In the appropriate row in Table 48, record your readings and calculations from (a)(ii), (iii), (iv) and (v).

Add appropriate headings with units to each column. (01 mark)

- (ii) Repeat the procedure in (a)(ii) to (a)(v) with the movable crocodile clip connected by B, C, D and E.

Record your readings and calculations in Table 48.

Table 48

Position of crocodile clip	n				
by A	5				
by B	4				
by C	3				
by D	2				
by E	1				

(03 marks)

- (c) From the experiment described above, identify: (03 marks)

- (i) The independent variable
- (ii) The dependent variable
- (iii) The constant variable

- (d) Using the grid on next page, plot a graph of R_{LED} (along the vertical axis) against I_{LED} (along the horizontal axis). Draw the curve of best fit. (04 marks)

- (e) The values of the supply voltage and the resistance of the resistors have been carefully selected for use with this LED in this practical exercise.

Suggest two reasons why these values are suitable.

1.
-
2.
-

(04 marks)

SAMPLE COPY

LINEAR MOTION

This chapter deals with the study of motion in a straight line.

TERMS USED IN LINEAR MOTION❖ **Distance:**

This is the length of path moved by the body

OR

This is the length between two points.

The SI unit of distance is a metre (m).

NOTE: Distance is a scalar quantity.

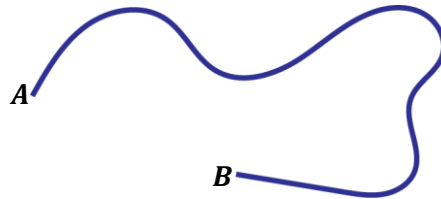

The person moves from point A to B regardless of any direction he/she takes. The length of path from A to B is called **distance**.

Therefore, distance is described by only magnitude hence a scalar quantity.

❖ **Displacement:**

This is the distance moved in a specified direction.

The SI unit of displacement is a metre (m).

NOTE: Displacement is a vector quantity.

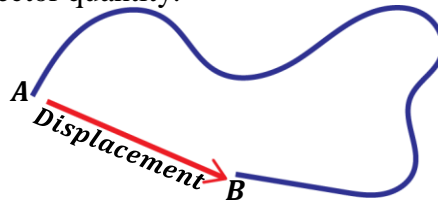

The person moves from point A to B in a specific direction. The distance moved in that direction is called **displacement**.

Therefore, displacement is described by both magnitude and direction hence a vector quantity.

❖ **Speed:**

This is the rate of change of distance with time.

$$\text{Speed} = \frac{\text{Distance}}{\text{Time}}$$

The SI unit of speed is metre per second (ms^{-1} or m/s).

NOTE: Speed is a scalar quantity.

Uniform speed:

This is the constant rate of change of distance with time.

A body is said to move with uniform speed if it covers equal distances in equal time intervals.

If the body moves with varying distances in unit time intervals, then the speed is non-uniform.

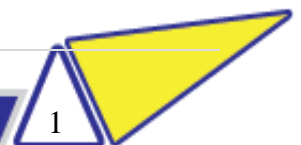

❖ Velocity:

This is the rate of change of displacement with time.

$$\text{Velocity} = \frac{\text{Displacement}}{\text{Time}}$$

The SI unit of displacement is metre per second (ms^{-1} or m/s).

NOTE: Velocity is a vector quantity.

Uniform velocity:

This is the constant rate of change of displacement with time.

A body is said to move with uniform velocity if its displacement changes by equal amounts in equal time intervals.

The figure below shows the displacement-time graph of a student moving around the school compound.

Displacement (m)	0	2	4	6
Time (s)	0	1	2	3

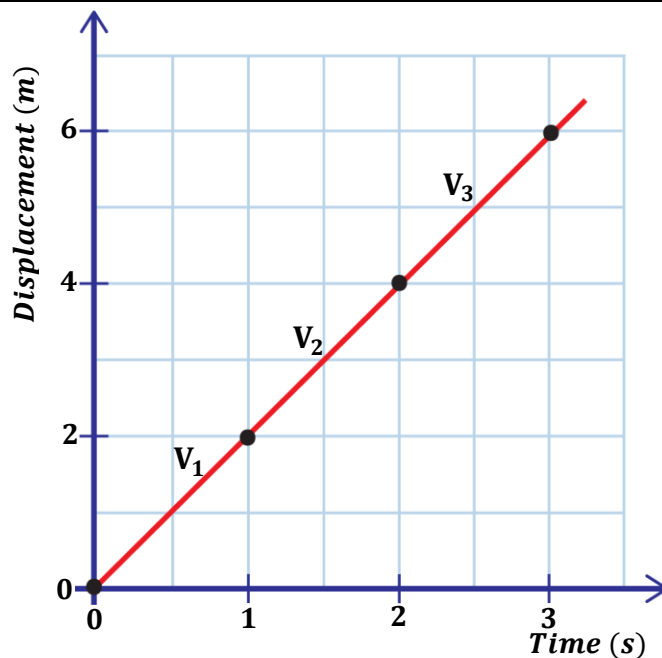

A body whose displacement is not constant in given time intervals is said to have non-uniform velocity.

Calculating the corresponding velocities of the student, we get;

$$\text{Velocity} = \frac{\text{displacement}}{\text{time}}$$

$$V_1 = \frac{2 - 0}{1 - 0} = 2ms^{-1}$$

$$V_2 = \frac{4 - 2}{2 - 1} = 2ms^{-1}$$

$$V_3 = \frac{6 - 4}{3 - 2} = 2ms^{-1}$$

Displacement (m)	0	2	4	6
Time (s)	0	1	2	3
Velocity (ms^{-1})	0	2	2	2

The figure below shows the velocity-time graph for the student's motion.

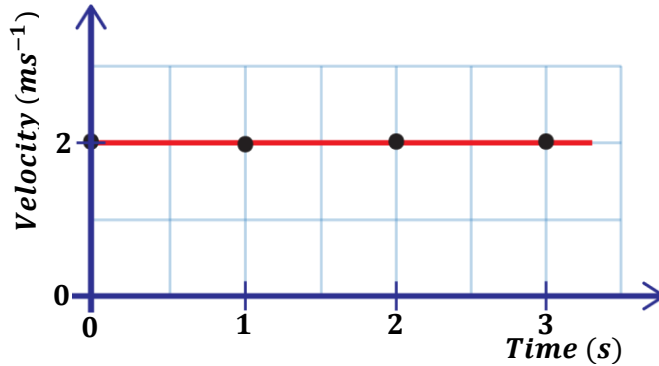

A straight-line graph is obtained showing that the velocity is constant or uniform.

Differences between Speed and Velocity

SPEED	VELOCITY
<ul style="list-style-type: none"> • It is the rate of change of distance with time. • It is a scalar quantity. 	<ul style="list-style-type: none"> • It is the rate of change of displacement with time. • It is a vector quantity.

TYPES OF VELOCITIES

Initial velocity, u :

This is the velocity with which the body starts its motion. i.e. it's the starting velocity.

NOTE:

- If a body starts from rest, its initial velocity, $u = 0ms^{-1}$.
- If a stationary body starts its motion, its initial velocity, $u = 0ms^{-1}$.
- If a body starts with a certain velocity, x , then its initial velocity, $u = xms^{-1}$.

Final velocity, v :

This is the velocity with which the body ends its motion. i.e. it's the ending velocity.

NOTE:

- If a body is brought to rest, its final velocity, $v = 0ms^{-1}$.
- If a body stops with a certain velocity, x , then its final velocity, $v = xms^{-1}$.

Average velocity:

This is the average of the initial and final velocity.

$$\text{Average velocity} = \frac{\text{Final velocity } (v) + \text{Initial velocity } (u)}{2}$$

❖ Acceleration:

This is the rate of change of velocity with time.

$$\text{Acceleration} = \frac{\text{Change in Velocity}}{\text{Time}}$$

$$\text{Acceleration} = \frac{\text{Final velocity } (v) - \text{Initial velocity } (u)}{\text{Time}}$$

The SI unit of acceleration is metre per second squared (ms^{-2} or m/s^2).

Question:

“A body has an acceleration of $2ms^{-2}$ ”. What do you understand by the statement?

The statement means that the velocity of the body increases by $2ms^{-1}$ every second.

Uniform acceleration:

This is the constant rate of change of velocity with time.

A body is said to move with uniform acceleration if its velocity changes by equal amounts in equal time intervals.

NOTE:

- A body with uniform velocity has **zero acceleration** because there is no change in velocity.
- Acceleration is either positive or negative. If the acceleration is increasing, then it is said to be positive and if it is decreasing (retarding or decelerating), it is said to be negative.

The figure below shows the velocity-time graph of a student moving around the school compound.

Velocity (ms^{-1})	0	4	8	12
Time (s)	0	1	2	3

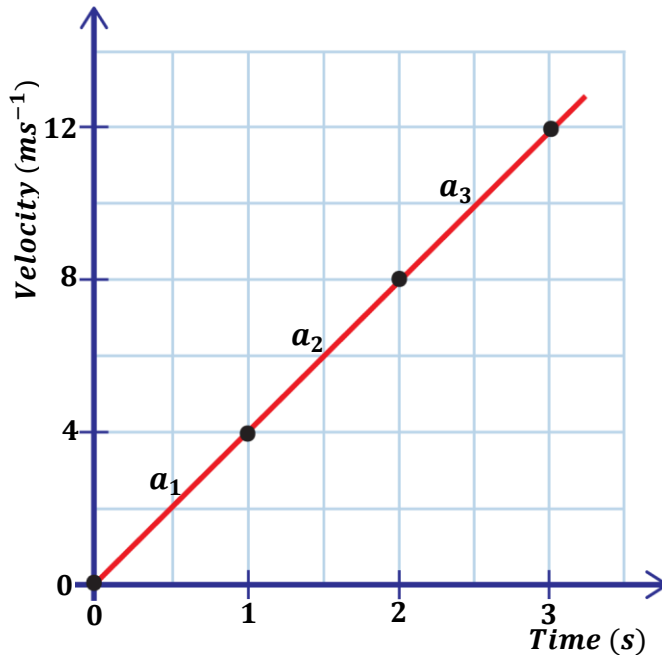

A straight-line graph is obtained showing that the acceleration is uniform.

Calculating the corresponding accelerations of the student, we get;

$$\text{Acceleration} = \frac{\text{change in velocity}}{\text{time}} \quad \left| \quad \begin{aligned} a_1 &= \frac{4 - 0}{1 - 0} = 4ms^{-2} \\ a_2 &= \frac{8 - 4}{2 - 1} = 4ms^{-2} \\ a_3 &= \frac{12 - 8}{3 - 2} = 4ms^{-2} \end{aligned} \right.$$

❖ Deceleration (Retardation):

When a body is moving with a decreasing velocity, then the body is said to be decelerating or retarding and the acceleration is negative.

Converting units of velocities

Convert the following units.

(a) 108 kmh^{-1} to ms^{-1}

$$\begin{aligned} \text{Distance} &= 108\text{km} \\ 1\text{km} &\equiv 1000\text{m} \\ 108\text{km} &\equiv d \\ d &= (108 \times 1000)\text{m} \\ d &= 108000\text{m} \end{aligned}$$

$$\begin{aligned} \text{time} &= 1 \text{ hour} \\ 1\text{hr} &= 3600\text{s} \end{aligned}$$

$$\begin{aligned} V &= \frac{d}{t} \\ V &= \frac{108000}{3600} \\ V &= 30\text{ms}^{-1} \end{aligned}$$

(b) 60 ms^{-1} to kmh^{-1}

$$\begin{aligned} \text{Distance} &= 60\text{m} \\ 1\text{km} &\equiv 1000\text{m} \\ d &\equiv 60\text{m} \\ d &= \frac{60}{1000}\text{km} \\ d &= 0.06\text{km} \end{aligned}$$

$$\begin{aligned} \text{time} &= 1 \text{ second} \\ 1\text{hr} &= 3600\text{s} \\ 1\text{s} &= \frac{1}{3600}\text{hrs} \end{aligned}$$

$$\begin{aligned} V &= \frac{d}{t} \\ V &= \frac{0.06}{1/3600} \\ V &= 216\text{ms}^{-1} \end{aligned}$$

Examples:

1. A car starts from rest and acquires a final velocity of 60ms^{-1} in 30s. Find the acceleration of the car.

$$\begin{aligned} u &= 0\text{ms}^{-1}, & v &= 60\text{ms}^{-1}, & t &= 30\text{s} \\ a &= \frac{v - u}{t} \\ a &= \frac{60 - 0}{30} \\ a &= 2\text{ms}^{-1} \end{aligned}$$

2. A body moving with a velocity of 80ms^{-1} changes to 60ms^{-1} in 2s. Find the deceleration of the body.

$$\begin{aligned} u &= 80\text{ms}^{-1}, & v &= 60\text{ms}^{-1}, & t &= 2\text{s} \\ a &= \frac{v - u}{t} \\ a &= \frac{60 - 80}{2} \\ a &= -10\text{ms}^{-1} \end{aligned}$$

EQUATIONS OF UNIFORMLY ACCELERATED MOTION

Consider a body starting with initial velocity, $u\text{ms}^{-1}$ and accelerates uniformly at a rate of, $a\text{ms}^{-2}$ to acquire a final velocity, $v\text{ms}^{-1}$ in time $t\text{s}$ and covers a displacement of $s\text{m}$ as shown below

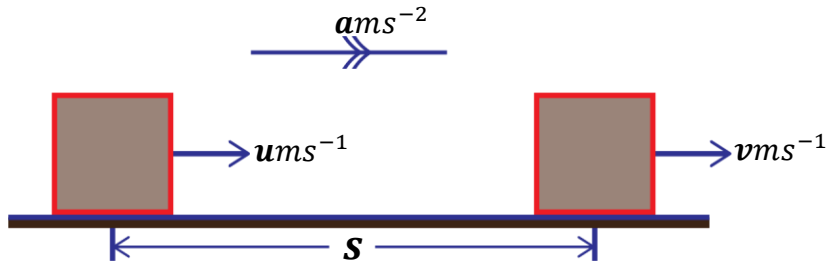
First equation of linear motion:

$$\text{Acceleration} = \frac{\text{change in velocity}}{\text{time taken}}$$

$$\text{Acceleration} = \frac{\text{final velocity} - \text{initial velocity}}{\text{time taken}}$$

$$a = \frac{v - u}{t}$$

$$at = v - u$$

$$\boxed{v = u + at} \text{ --- (i)}$$

Second equation of linear motion:

From the definition of displacement,

$$\text{Displacement} = \text{Average velocity} \times \text{Time}$$

$$s = \left(\frac{u + v}{2}\right) \times t$$

$$2s = (u + v)t$$

From equation (i), $v = u + at$

$$2s = (u + u + at)t$$

$$2s = (2u + at)t$$

$$2s = 2ut + at^2$$

$$s = \frac{2ut}{2} + \frac{at^2}{2}$$

$$\boxed{s = ut + \frac{1}{2}at^2}$$

Third equation of linear motion:

From the definition of displacement,

$$\text{Displacement} = \text{Average velocity} \times \text{Time}$$

$$s = \left(\frac{u + v}{2}\right) \times t$$

From equation (i),

$$t = \frac{v - u}{a}$$

$$s = \left(\frac{u + v}{2}\right) \times \left(\frac{v - u}{a}\right)$$

$$s = \frac{(u + v)(v - u)}{2a}$$

$$2as = uv - u^2 + v^2 - uv$$

$$\boxed{v^2 = u^2 + 2as}$$

In summary, the three equations of uniformly accelerated motion are;

First equation: $v = u + at$

Second equation: $s = ut + \frac{1}{2}at^2$

Third equation: $v^2 = u^2 + 2as$

Examples:

1. A car accelerated from a velocity of $10ms^{-1}$ to $30ms^{-1}$ in 4s. Calculate
- Acceleration of the car.
 - Distance moved by the car.

(i)

$$u = 10ms^{-1} \quad v = 30ms^{-1} \quad t = 4s$$

$$v = u + at$$

$$a = \frac{v - u}{t}$$

$$a = \frac{30 - 10}{4}$$

$$a = \frac{20}{4}$$

$$a = 5ms^{-2}$$

(ii)

$$s = ut + \frac{1}{2}at^2$$

$$s = 10 \times 4 + \frac{1}{2} \times 5 \times 4^2$$

$$s = 40 + \frac{1}{2} \times 5 \times 16$$

$$s = 40 + 40$$

$$s = 80m$$

2. A body starts from rest and accelerates uniformly to a velocity of $15ms^{-1}$ at a rate of $5ms^{-2}$. Calculate the distance moved by the body.

$$u = 0ms^{-1} \quad v = 15ms^{-1} \quad a = 5ms^{-2}$$

$$v^2 = u^2 + 2as$$

$$15^2 = 0^2 + 2 \times 5 \times s$$

$$225 = 0 + 10s$$

$$s = \frac{225}{10}$$

$$s = 22.5m$$

3. A body moving with a velocity of $20ms^{-1}$ accelerates to a velocity of $30ms^{-1}$ in 5 seconds. Calculate;

- Acceleration of the body.
- Distance moved by the body.

(i)

$$u = 20ms^{-1} \quad v = 30ms^{-1} \quad t = 5s$$

$$v = u + at$$

$$a = \frac{v - u}{t}$$

$$a = \frac{30 - 20}{5}$$

$$a = \frac{10}{5}$$

$$a = 2ms^{-2}$$

(ii)

$$s = ut + \frac{1}{2}at^2$$

$$s = 20 \times 5 + \frac{1}{2} \times 2 \times 5^2$$

$$s = 100 + \frac{1}{2} \times 2 \times 25$$

$$s = 100 + 25$$

$$s = 125m$$

4. A car moving with a velocity of 25ms^{-1} retards uniformly at a rate of 2.5ms^{-2} . Calculate;
- Velocity of the car after 8s.
 - Time it takes to come to rest.
 - Distance moved by the car.

$$u = 25\text{ms}^{-1} \quad a = -2.5\text{ms}^{-2}$$

(i)

$$\begin{aligned} t &= 8\text{s} \\ v &= u + at \\ v &= 25 + (-2.5) \times 8 \\ v &= 25 - 20 \\ v &= 5\text{ms}^{-1} \end{aligned}$$

(ii)

$$\begin{aligned} v &= 0\text{ms}^{-1} \\ v &= u + at \\ 0 &= 25 + (-2.5)t \\ t &= \frac{-25}{-2.5} \\ t &= 10\text{s} \end{aligned}$$

(iii)

$$\begin{aligned} s &= ut + \frac{1}{2}at^2 \\ s &= 25 \times 10 + \frac{1}{2} \times (-2.5) \times 10^2 \\ s &= 250 + \frac{1}{2} \times (-2.5) \times 100 \\ s &= 250 - 125 \\ s &= 125\text{m} \end{aligned}$$

OR

$$\begin{aligned} v^2 &= u^2 + 2as \\ 0^2 &= 25^2 + 2 \times (-2.5) \times s \\ 0 &= 625 - 5s \\ s &= \frac{625}{5} \\ s &= 125\text{m} \end{aligned}$$

5. A car travelling at 90kmh^{-1} is uniformly brought to rest in 40 seconds. Calculate its acceleration.

$$u = 90\text{kmh}^{-1} \quad v = 0\text{ms}^{-1} \quad t = 40\text{s}$$

Converting initial velocity to ms^{-1}

$$\text{distance} = 90\text{km} \quad \text{time} = 1\text{hour}$$

$$u = \frac{\text{distance (m)}}{\text{time (s)}}$$

$$u = \frac{90 \times 1000}{3600}$$

$$u = 25\text{ms}^{-1}$$

$$\begin{aligned} v &= u + at \\ v - u &= at \\ a &= \frac{v - u}{t} \\ a &= \frac{0 - 25}{40} \\ a &= \frac{-25}{40} \\ a &= -0.625\text{ms}^{-2} \end{aligned}$$

6. A driver of a bus initially travelling at 72kmh^{-1} applies the brakes on seeing crossing elephants. The bus comes to rest in 5 seconds. Calculate;

- the retardation of the bus.
- Distance travelled in this interval.

$$u = 72\text{kmh}^{-1} \quad v = 0\text{ms}^{-1} \quad t = 5\text{s}$$

Converting initial velocity to ms^{-1}

$$\text{distance} = 72\text{km} \quad \text{time} = 1\text{hour}$$

$$u = \frac{\text{distance (m)}}{\text{time (s)}}$$

$$u = \frac{72 \times 1000}{3600}$$

$$u = 20\text{ms}^{-1}$$

$$\begin{aligned} v &= u + at \\ v - u &= at \\ a &= \frac{v - u}{t} \\ a &= \frac{0 - 20}{5} \\ a &= \frac{-20}{5} \\ a &= -4\text{ms}^{-2} \end{aligned}$$

$$\begin{aligned} s &= ut + \frac{1}{2}at^2 \\ s &= 20 \times 5 + \frac{1}{2} \times (-4) \times 5^2 \\ s &= 100 + \frac{1}{2} \times (-4) \times 25 \\ s &= 100 - 50 \\ s &= 50\text{m} \end{aligned}$$

EXERCISE:

1. A body starts from rest and accelerates uniformly to a velocity of 25ms^{-1} at a rate of 2.5ms^{-2} . Calculate the distance moved by the body.
2. A particle initially moving with a velocity of 5ms^{-1} accelerates uniformly at 4ms^{-2} . Find
 - i) the velocity of the particle after 8s.
 - ii) the displacement of the particle after 10s.
 - iii) displacement by the time its velocity is 25ms^{-1} .
3. A car moving with a velocity of 25ms^{-1} retards uniformly at a rate of 2.5ms^{-2} . Calculate;
 - i) Velocity of the car after 8s.
 - ii) Time it takes to come to rest.
 - iii) Distance moved by the car.
4. A body traveling at 90kmh^{-1} is retarded to rest at 20ms^{-2} . Calculate the distance covered.
5. A car on a straight road accelerates from rest to a speed of 30ms^{-1} in 5s. it then travels at the same speed for 5 minutes and then brakes for 10s in order to come to stop. Calculate the;
 - i) acceleration of the car during the motion.
 - ii) deceleration of the car.
 - iii) total distance travelled.
6. Calculate the final (maximum) velocity of a body travelling at 4ms^{-1} , when it accelerates at 2ms^{-2} and covers a distance of 5m.
7. A car travelling at 40ms^{-1} is uniformly decelerated to 25ms^{-1} for 5s. Calculate the total distance covered.

MOTION GRAPHS

These are graphs that represent the motion of the body moving in a straight line.
They include;

(a) **DISPLACEMENT-TIME GRAPHS**

These are graphs of motion with displacement of a body along the vertical axis and time along the horizontal axis.

The graphs below show displacement-time graphs for a body;

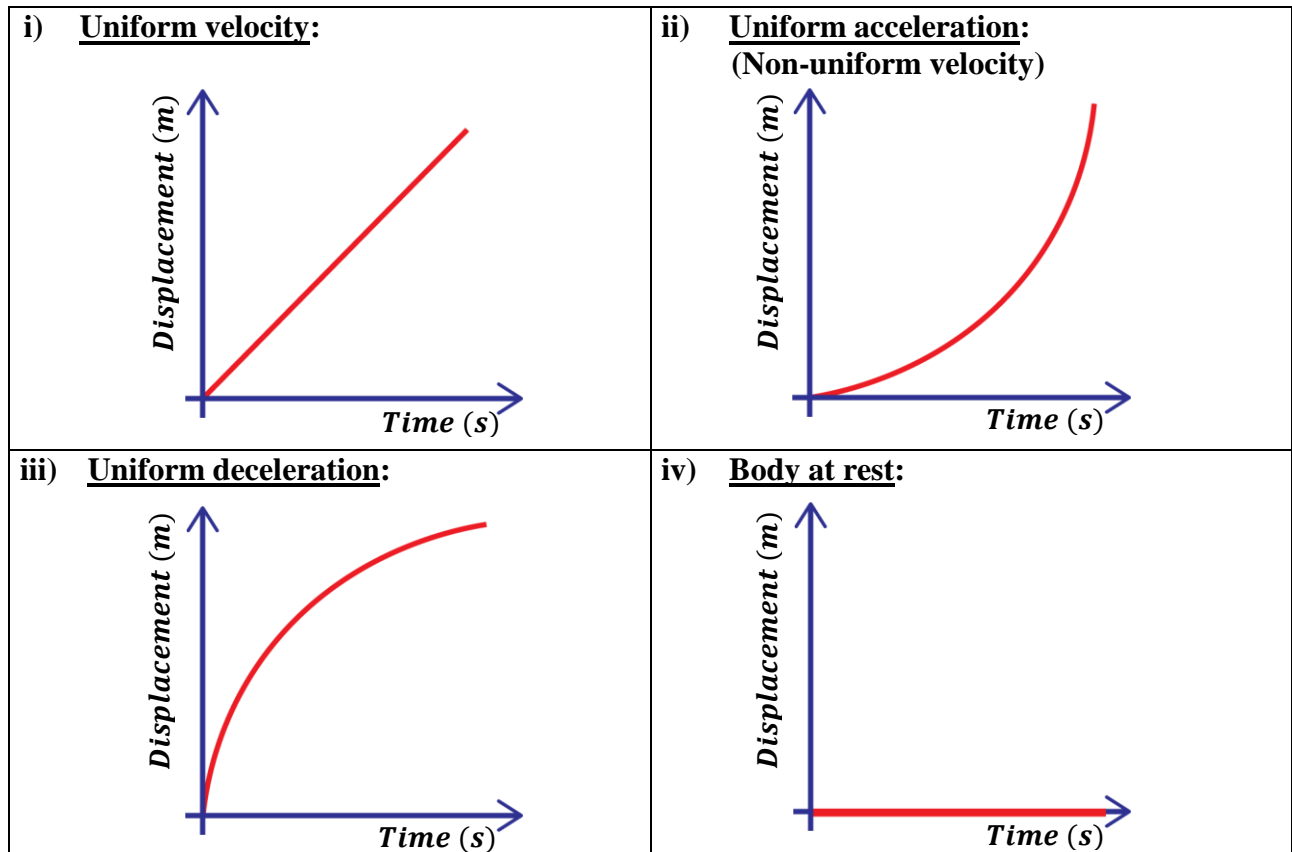

(b) **VELOCITY-TIME GRAPHS**

These are graphs of motion with velocity of a body along the vertical axis and time along the horizontal axis.

The graphs below show velocity-time graphs for a body;

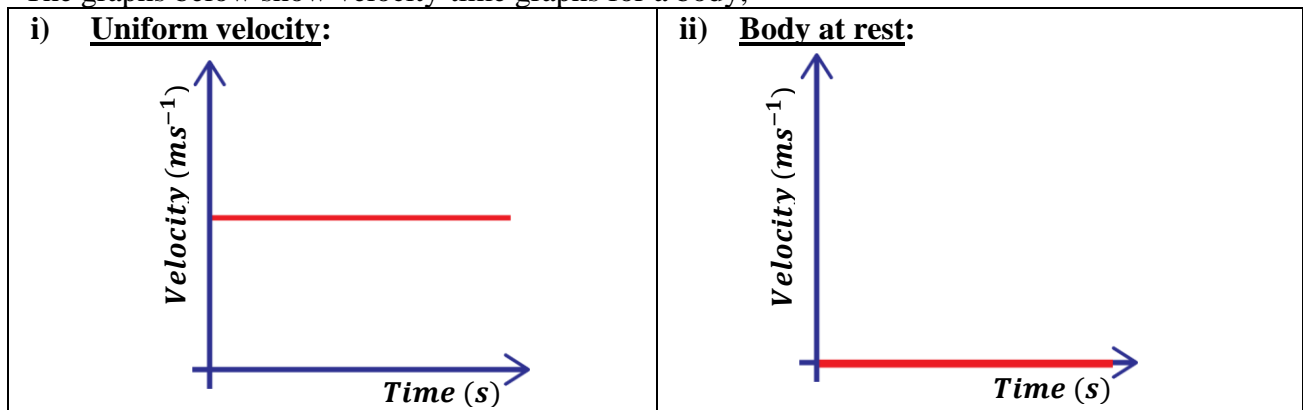

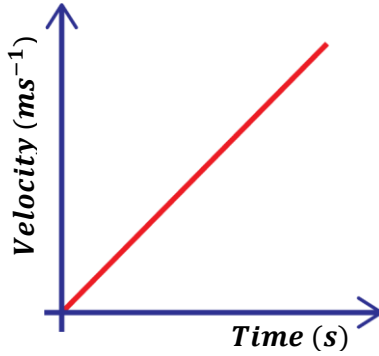
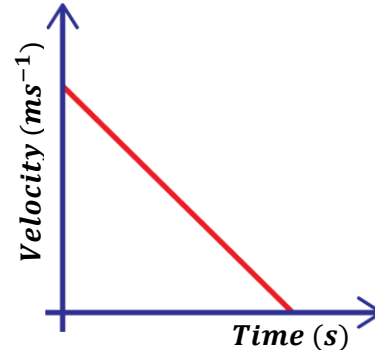
iii) Uniform acceleration:

iv) Uniform deceleration:

(c) ACCELERATION-TIME GRAPHS

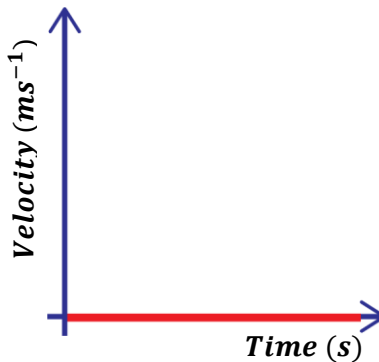
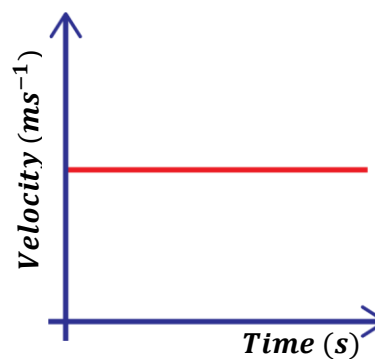
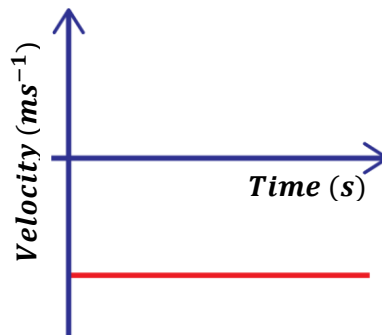
These are graphs of motion with acceleration of a body along the vertical axis and time along the horizontal axis.

The graphs below show acceleration-time graphs for a body;

i) Uniform velocity:

ii) Uniform acceleration:

iii) Uniform deceleration:

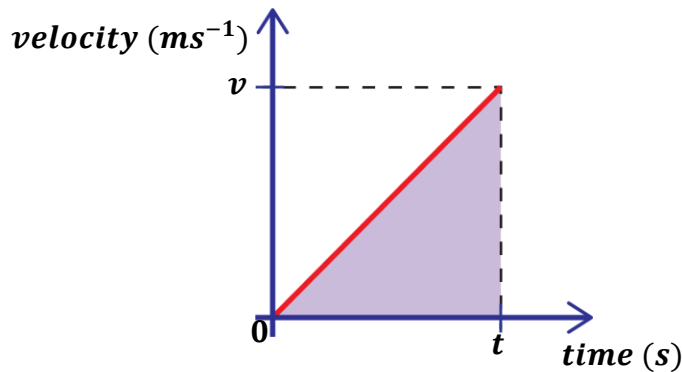
AREA UNDER A VELOCITY-TIME GRAPH

Consider a body starting from rest and accelerates uniformly to a velocity, $v\text{ms}^{-1}$ in time $t\text{s}$.



Distance covered = Average velocity \times Time

$$\text{Distance covered} = \left(\frac{\text{final velocity} + \text{initial velocity}}{2} \right) \times \text{Time}$$

$$\text{Distance covered} = \left(\frac{v + u}{2} \right) \times t$$

$$\text{Distance covered} = \left(\frac{v + 0}{2} \right) \times t$$

$$\text{Distance covered} = \frac{1}{2}vt = \text{Area of triangle under the graph}$$

NOTE:

- ❖ Therefore, distance covered by the body is equal to the area under the velocity-time graph.
- ❖ Average velocity of the body under motion is given by;

$$\text{Average velocity} = \frac{\text{Total distance}}{\text{Total time}}$$

Examples:

1. Describe the motion of the car for the graphs below.

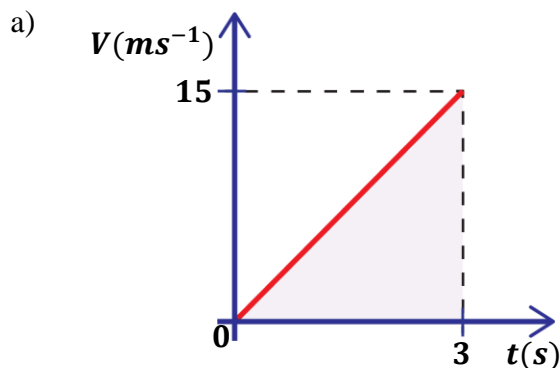

From, $v = u + at$

Then, $a = \frac{v - u}{t}$

$u = 0\text{ms}^{-1}$ $v = 15\text{ms}^{-1}$ $t = 3\text{s}$

$$a = \frac{15 - 0}{3}$$

$$a = \frac{15}{3}$$

$$a = 5\text{ms}^{-2}$$

A car starts from rest (with velocity of 0ms^{-1}) and accelerates uniformly at a rate of 5ms^{-2} to a velocity of 15ms^{-1} in 3 seconds.

b)

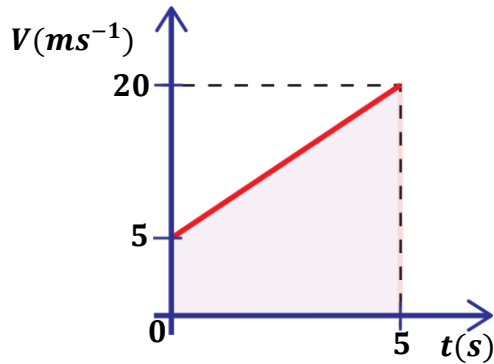

From, $v = u + at$

Then, $a = \frac{v - u}{t}$

$u = 5\text{ms}^{-1}$ $v = 20\text{ms}^{-1}$ $t = 5\text{s}$

$$a = \frac{20 - 5}{5}$$

$$a = \frac{15}{5}$$

$$a = 3\text{ms}^{-2}$$

A car starts from with a velocity of 5ms^{-1} and accelerates uniformly at a rate of 3ms^{-2} to a velocity of 20ms^{-1} in 5 seconds.

OR

A car moving with a velocity of 5ms^{-1} accelerates uniformly to a velocity of 20ms^{-1} with an acceleration of 3ms^{-2} .

c)

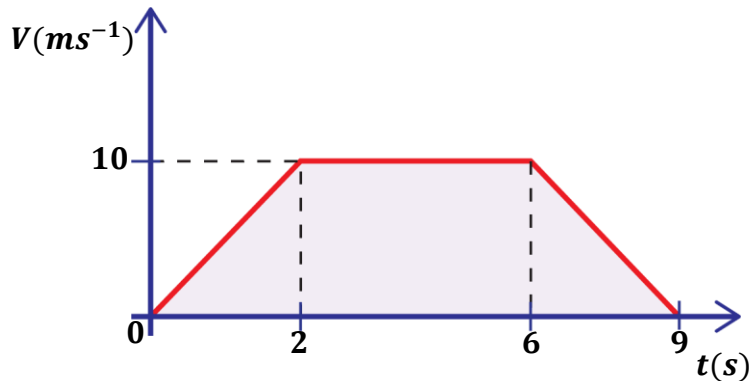

For uniform acceleration

From, $a = \frac{v - u}{t}$

$u = 0\text{ms}^{-1}$ $v = 10\text{ms}^{-1}$ $t = 2\text{s}$

$$a = \frac{10 - 0}{2}$$

$$a = \frac{10}{2}$$

$$a = 5\text{ms}^{-2}$$

For uniform deceleration

From, $a = \frac{v - u}{t}$

$u = 10\text{ms}^{-1}$ $v = 0\text{ms}^{-1}$ $t = (9 - 6) = 3\text{s}$

$$a = \frac{0 - 10}{3}$$

$$a = \frac{-10}{3}$$

$$a = -3.33\text{ms}^{-2}$$

A car starts from rest and accelerates uniformly at a rate of 5ms^{-2} to velocity of 10ms^{-1} in 2s. It maintains this velocity for 4s and it then finally decelerates uniformly at a rate of 3.33ms^{-2} to rest in 3 seconds.

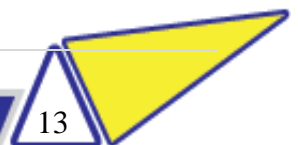

2. The figure below is a velocity-time graph of a car.

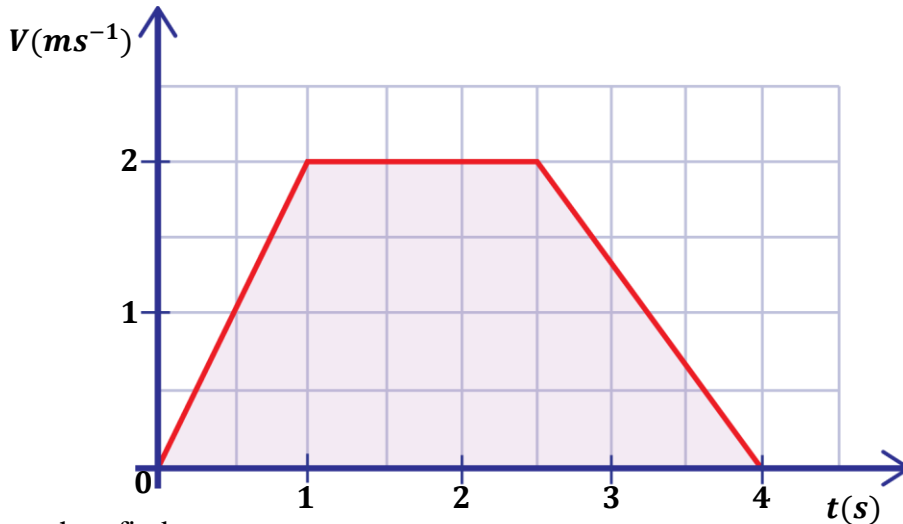

Use the graph to find;

- the acceleration of the car.
- the deceleration of the car.
- the total distance covered by the car.
- the average velocity of the car.

i) For uniform acceleration

$$\text{From, } a = \frac{v - u}{t}$$

$$u = 0\text{ms}^{-1} \quad v = 2\text{ms}^{-1} \quad t = 1\text{s}$$

$$a = \frac{2 - 0}{1}$$

$$a = \frac{2}{1}$$

$$a = 2\text{ms}^{-2}$$

ii) For uniform deceleration

$$\text{From, } a = \frac{v - u}{t}$$

$$u = 2\text{ms}^{-1} \quad v = 0\text{ms}^{-1} \quad t = (4 - 2.5) = 1.5\text{s}$$

$$a = \frac{0 - 2}{1.5}$$

$$a = \frac{-2}{1.5}$$

$$a = -1.33\text{ms}^{-2}$$

iii) Total distance covered

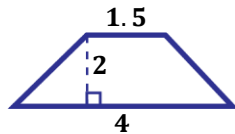

Distance = Area of a trapezium

$$\text{Distance} = \frac{1}{2}h(a + b)$$

$$\text{Distance} = \frac{1}{2} \times 2(1.5 + 4)$$

$$\text{Distance} = \frac{11}{2}$$

$$\text{Distance} = 5.5\text{m}$$

iv) Average velocity

$$\text{Average velocity} = \frac{\text{Total distance}}{\text{Total time}}$$

$$\text{Average velocity} = \frac{5.5}{4}$$

$$\text{Average velocity} = 1.375\text{ms}^{-1}$$

3. Sketch the velocity-time graphs for the information below and calculate the distance covered.
- a) A boat is moving with a velocity of 15ms^{-1} for 10s. It is then brought to rest.

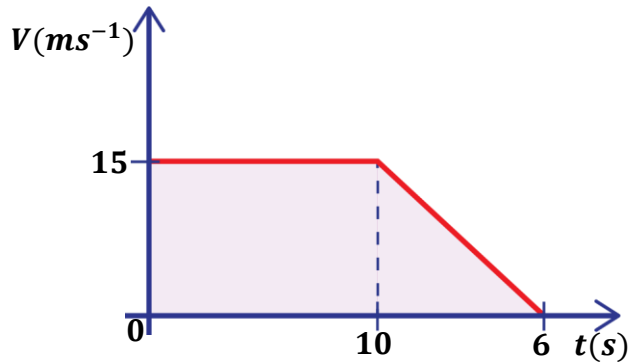

Total distance covered

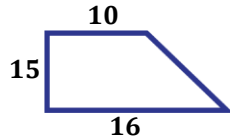

Distance = Area of a trapezium

$$\text{Distance} = \frac{1}{2}h(a + b)$$

$$\text{Distance} = \frac{1}{2} \times 15(10 + 16)$$

$$\text{Distance} = \frac{390}{2}$$

$$\text{Distance} = 195\text{m}$$

OR

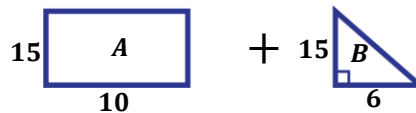

Distance = Area of rectangle A + Area of triangle B

$$\text{Distance} = (l \times w) + \frac{1}{2}bh$$

$$\text{Distance} = (10 \times 15) + \frac{1}{2} \times 6 \times 15$$

$$\text{Distance} = 150 + 45$$

$$\text{Distance} = 195\text{m}$$

- b) A car starts with a velocity of 10ms^{-1} and accelerates uniformly for 20s to a velocity of 30ms^{-1} . It then maintains this velocity for 60s and finally decelerates uniformly to rest for 10s.

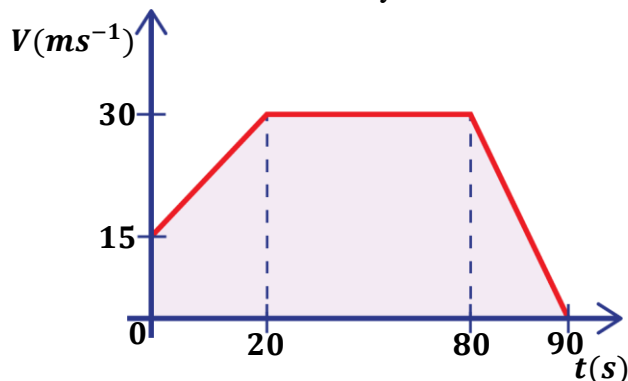

Total distance covered

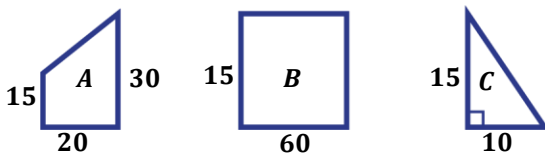

Distance = Area of trapezium A + Area of rectangle B + Area of triangle C

$$\begin{aligned} \text{Distance} &= \frac{1}{2}h(a + b) + (l \times w) + \frac{1}{2}bh \\ &= \frac{1}{2} \times 20(15 + 30) + (60 \times 15) + \frac{1}{2} \times 10 \times 15 \end{aligned}$$

$$\text{Distance} = \frac{900}{2} + 900 + \frac{150}{2}$$

$$\text{Distance} = 450 + 900 + 75$$

$$\text{Distance} = 1425\text{m}$$

4. A boat traveling at 10ms^{-1} uniformly accelerated for 4s at 2ms^{-2} to a maximum speed. It then moves with this maximum speed for 5s after it is uniformly brought to rest in another 3s .
- Draw a velocity-time graph for the motion of the boat.
 - Calculate the maximum speed.
 - Calculate the deceleration of the boat.

i)

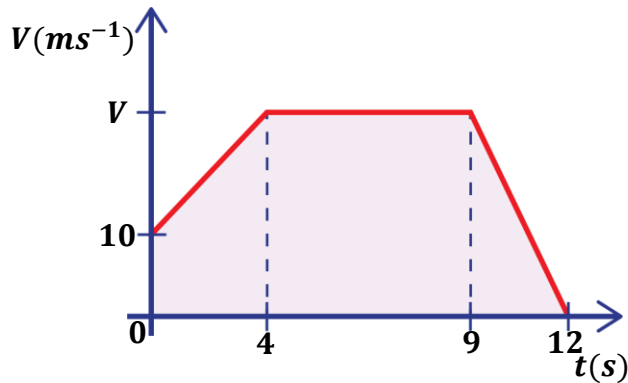

ii) Maximum velocity

$$a = 2\text{ms}^{-2} \quad t = 4\text{s} \quad u = 10\text{ms}^{-1}$$

$$v = u + at$$

$$V = 10 + 2 \times 4$$

$$V = 10 + 8$$

$$V = 18\text{ms}^{-1}$$

ii) Deceleration of the boat

$$v = 0\text{ms}^{-1} \quad t = 3\text{s} \quad u = 18\text{ms}^{-1}$$

$$v = u + at$$

$$0 = 18 + a \times 3$$

$$a = \frac{-18}{3}$$

$$a = -6\text{ms}^{-2}$$

5. The velocity-time graph below represents the motion of two cars P and Q which start from the same place and move in the same direction. Use the graph to answer the following questions.

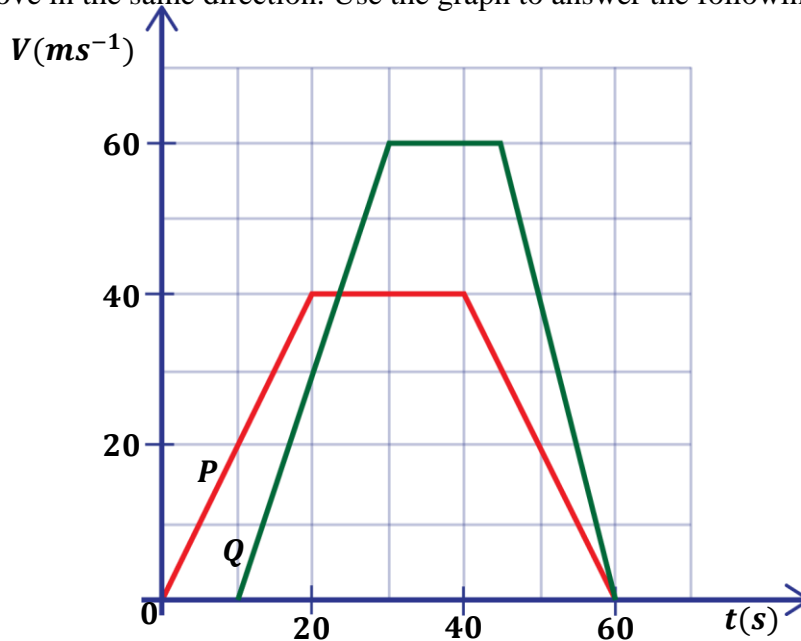

- Calculate the accelerations of cars P and Q.
- Determine how far the cars are from each other at the end of their accelerations.
- Find the distance covered by car P between the 20th and 40th seconds.
- Describe the motion of car Q.

i) For acceleration of car P

$$\begin{aligned} \text{From, } v &= u + at \\ u = 0\text{ms}^{-1} \quad v &= 40\text{ms}^{-1} \quad t = 20\text{s} \\ 40 &= 0 + a \times 20 \\ a &= \frac{40}{20} \\ a &= 2\text{ms}^{-2} \end{aligned}$$

For acceleration of car Q

$$\begin{aligned} \text{From, } v &= u + at \\ u = 0\text{ms}^{-1} \quad v &= 60\text{ms}^{-1} \quad t = 20\text{s} \\ 60 &= 0 + a \times 20 \\ a &= \frac{60}{20} \\ a &= 3\text{ms}^{-2} \end{aligned}$$

ii) For distance covered by car P during its acceleration

$$\begin{aligned} \text{From, } S_P &= ut + \frac{1}{2}at^2 \\ u = 0\text{ms}^{-1} \quad a &= 2\text{ms}^{-2} \quad t = 20\text{s} \\ S_P &= 0 \times 20 + \frac{1}{2} \times 2 \times 20^2 \\ S_P &= \frac{800}{2} \\ S_P &= 400\text{m} \end{aligned}$$

For distance covered by car Q during its acceleration

$$\begin{aligned} \text{From, } S_Q &= ut + \frac{1}{2}at^2 \\ u = 0\text{ms}^{-1} \quad a &= 3\text{ms}^{-2} \quad t = 20\text{s} \\ S_Q &= 0 \times 20 + \frac{1}{2} \times 3 \times 20^2 \\ S_Q &= \frac{1200}{2} \\ S_Q &= 600\text{m} \end{aligned}$$

Difference between the distance of the cars at the end of their accelerations.

$$\text{Difference} = (600 - 400)\text{m} = 200\text{m}$$

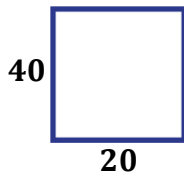
(iii)

Distance = Area of the rectangle

$$\text{Distance} = l \times w$$

$$\text{Distance} = 20 \times 40$$

$$\text{Distance} = 800\text{m}$$

iv) deceleration of car Q

$$\begin{aligned} \text{From, } v &= u + at \\ u = 60\text{ms}^{-1} \quad v &= 0\text{ms}^{-1} \quad t = (60 - 45) = 15\text{s} \\ 0 &= 60 + a \times 15 \\ a &= \frac{-60}{15} \\ a &= -4\text{ms}^{-2} \end{aligned}$$

A car P starts from rest and accelerates uniformly at a rate of 3ms^{-2} to velocity of 60ms^{-1} in 2s. It maintains this velocity for 15s and it then finally decelerates uniformly at a rate of 4ms^{-2} to rest in 15 seconds.

6. The table below represents the velocity of a vehicle after a given time.

Velocity (ms^{-1})	0	3	6	9	12	15	15	15	15	15
Time (s)	0	1	2	3	4	5	6	7	8	9

- Plot a velocity-time graph representing the motion of the vehicle.
- Find the slope of the vehicle (slope is equal to acceleration of the vehicle)
- Find the total displacement for the whole vehicle.
- Use the graph to describe the motion of the vehicle.

i)

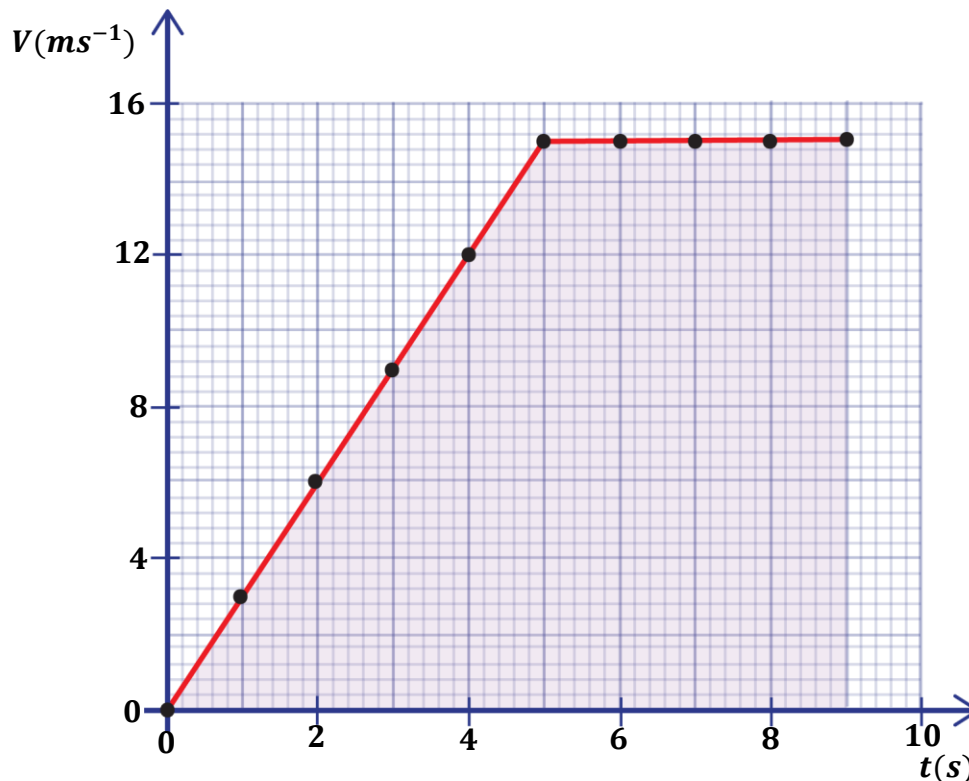
 ii) For uniform acceleration(slope)

$$\text{From, } a = \frac{v - u}{t}$$

$$u = 0ms^{-1} \quad v = 15ms^{-1} \quad t = 5s$$

$$a = \frac{15 - 0}{5}$$

$$a = \frac{15}{5}$$

$$a = 3ms^{-2}$$

 iii) Total displacement

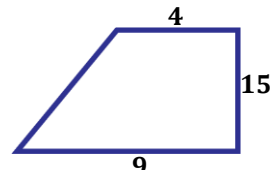

$$\text{Distance} = \frac{1}{2}h(a + b)$$

$$\text{Distance} = \frac{1}{2} \times 15(4 + 9)$$

$$\text{Distance} = \frac{195}{2}$$

$$\text{Distance} = 97.5m$$

 iv) A vehicle starting from rest accelerates uniformly at a rate of $3ms^{-2}$ to a velocity of $15ms^{-1}$ in 5 seconds. It then maintains this new velocity for 4 seconds.

7. A car of mass $20kg$ travelling with a uniform velocity of $25ms^{-1}$ for $5s$ brakes and then comes to rest under a uniform deceleration in $8s$.
- Sketch a velocity-time graph for the motion.
 - Find the retardation.
 - Calculate the retarding force of the car.
 - Find the total distance travelled.

i)

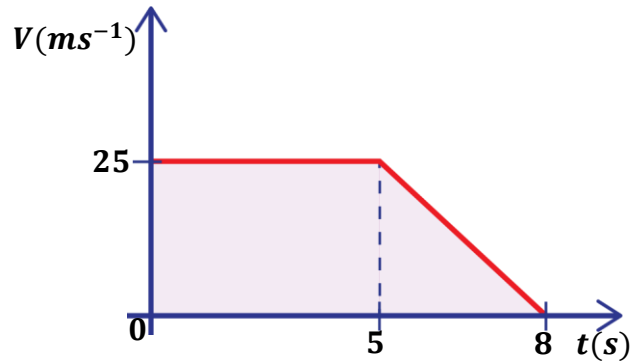
 ii) Retardation

$$v = 0 \text{ms}^{-1}$$

$$t = 3 \text{s} \quad u = 25 \text{ms}^{-1}$$

$$v = u + at$$

$$0 = 25 + a \times 3$$

$$a = \frac{-25}{3}$$

$$a = -8.33 \text{ms}^{-2}$$

 ii) Retarding force

$$m = 2 \text{kg}$$

$$a = 8.33 \text{ms}^{-2}$$

$$F = ma$$

$$F = 2 \times 8.33$$

$$F = 16.7 \text{N}$$

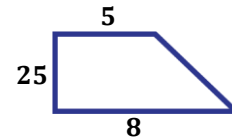
 iii) Total distance

Distance = Area of a trapezium

$$\text{Distance} = \frac{1}{2}h(a + b)$$

$$\text{Distance} = \frac{1}{2} \times 25(5 + 8)$$

$$\text{Distance} = \frac{325}{2}$$

$$\text{Distance} = 162.5 \text{m}$$

8. A car accelerated uniformly from a velocity of 10ms^{-1} to a velocity of 30ms^{-1} in 20s. It then moved with a constant velocity for 5s. It accelerates uniformly again to a velocity of 70ms^{-1} in 15s. The brakes are then applied and it comes to rest uniformly in a further 8s.

- Draw a velocity-time graph for the motion of the car.
- Calculate the distance covered by the car.
- Calculate the average velocity of the car.

i)

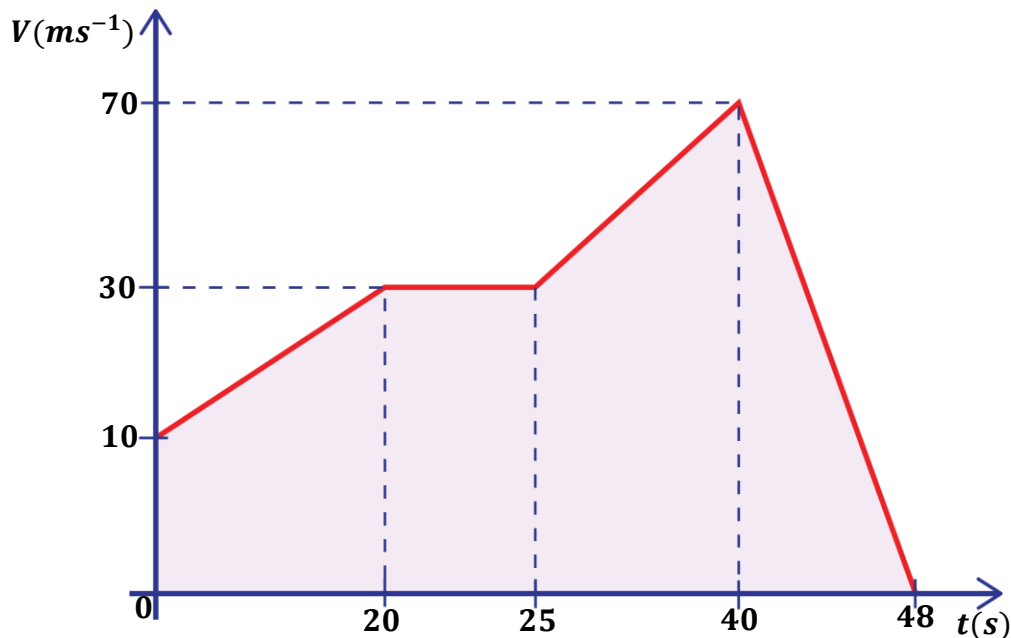

ii)

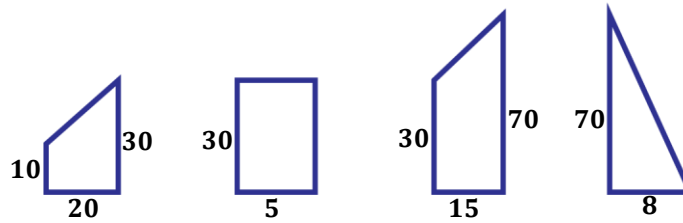

Distance = Area of trapezium A + Area of rectangle B + Area of trapezium C + Area of triangle D

$$\text{Distance} = \frac{1}{2}h(a + b) + (l \times w) + \frac{1}{2}h(a + b) + \frac{1}{2}bh$$

$$\text{Distance} = \frac{1}{2} \times 20(10 + 30) + (30 \times 5) + \frac{1}{2} \times 15(30 + 70) + \frac{1}{2} \times 8 \times 70$$

$$\text{Distance} = \frac{800}{2} + 150 + \frac{1500}{2} + \frac{560}{2}$$

$$\text{Distance} = 400 + 150 + 750 + 280$$

$$\text{Distance} = 1580\text{m}$$

EXERCISE.

- A car moves from rest with a uniform acceleration of 1ms^{-2} for the first 20s. It continues at a constant velocity for the next 30s and finally takes 10s to decelerate uniformly to rest.
 - Calculate the constant velocity reached after 20s.
 - Sketch a velocity-time graph for the whole journey.
 - Calculate the distance travelled by the car.
- A car starting from rest at P accelerates uniformly for 10s to a velocity of 25ms^{-1} . It then moves at this constant velocity for 8s before retarding uniformly for 5s so as to stop at Q. Sketch a velocity-time graph for the motion and find;
 - the distance covered during each of the parts of the journey described.
 - the acceleration of the car.
 - The retardation of the car.
- The figure shows the motion of a car with an acceleration of 2ms^{-2} .

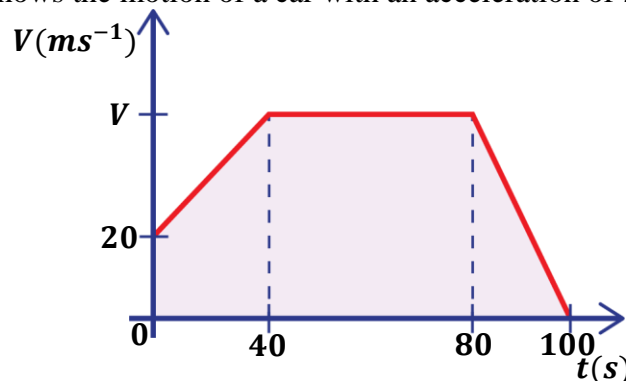

- Describe the motion of the car.
- Find the distance moved after 50s.
- Find the total distance travelled by the car.

4. A car travels at a velocity of 20ms^{-1} for 6s. It is then uniformly brought to rest in 4s.
- Draw a velocity against time graph.
 - Calculate the retardation.
 - Find the total distance travelled.
 - Calculate the average speed of the body.

5. The graph below shows motion of a body. Use it to answer the following questions;

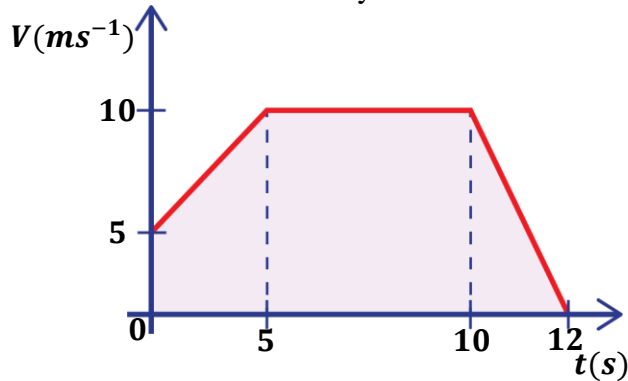

- Describe the motion of the body.
 - Calculate the acceleration and the retardation of the body.
 - Calculate the total distance covered by the body.
 - Calculate the average velocity of the body.
6. Plot a velocity-time graph of the body for the information below and use it to answer the questions.

Velocity (ms^{-1})	0	9	18	27	36	45	54
Time (s)	0	5	10	15	20	25	30

- Describe the motion of the body.
 - Calculate the acceleration of the body
 - Calculate the total displacement of the body.
7. The table below shows the velocity attained by a moving particle in a given time.

Velocity (ms^{-1})	5	13	21	29	39	39	39	27	15	3
Time (s)	0	2	4	6	8	10	12	14	16	18

Draw a velocity-time graph and describe the motion of the particle.

Use it to find;

- Distance move while accelerating.
- Acceleration and retardation of the particle.
- The time that would have elapsed when it comes to rest.

MOTION UNDER GRAVITY

When a body is moving under gravity (upwards or downwards), it attains a constant acceleration called acceleration due to gravity (g). This constant acceleration is equal to $9.8 \text{ ms}^{-2} \approx 10 \text{ ms}^{-2}$.

Definition:

Acceleration due to gravity is the rate of change of velocity with time for a freely falling body under the force of gravity.

NOTE: Acceleration due to gravity varies from place to place because;

- The earth is not a perfect sphere.
- The earth is always rotating.

Since the force of gravity acts vertically downwards;

- bodies moving vertically downwards are moving in the same direction as the force of gravity so, they have a positive acceleration due to gravity ($+g \text{ ms}^{-2}$).

The equations of motion are;

First equation: $v = u + gt$

Second equation: $s = ut + \frac{1}{2}gt^2$

Third equation: $v^2 = u^2 + 2gs$

- bodies moving vertically upwards are moving in the direction opposite to the force of gravity so, they have a negative acceleration due to gravity ($-g \text{ ms}^{-2}$).

The equations of motion are;

First equation: $v = u - gt$

Second equation: $s = ut - \frac{1}{2}gt^2$

Third equation: $v^2 = u^2 - 2gs$

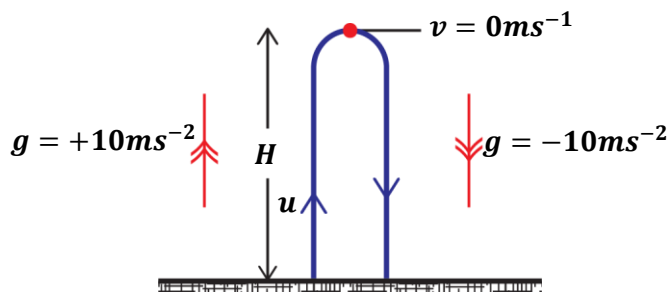

IMPORTANT TERMS:

Maximum height, H:

This is the greatest height reached by the body from the point of projection.

At maximum height, **velocity** = 0 ms^{-1}

Time of flight, T:

This is the total time taken by a body from its point of projection until it lands.

Time of flight is twice the time taken by the body to reach maximum height.

Let time taken to reach maximum height = t

Then; $T = 2t$

Trajectory:

This is the path followed by a projectile.

Examples:

(where necessary apply ($g = 10\text{ms}^{-2}$))

1. A stone is thrown vertically upwards with an initial velocity of 25ms^{-1} .

- a) Determine the time taken to reach maximum height.
b) What is the maximum height reached by the stone

a)

At maximum height, $v = 0\text{ms}^{-1}$
 $u = 25\text{ms}^{-1}$ $g = -10\text{ms}^{-2}$
From $v = u + gt$
 $0 = 25 + -10 \times t$
 $-25 = -10t$
 $t = \frac{-25}{-10}$
 $t = 2.5\text{s}$

b)

From $v^2 = u^2 + 2gs$
Let maximum height = H
 $0^2 = 25^2 + 2 \times -10 \times H$
 $20H = 625$
 $H = \frac{625}{20}$
 $H = 31.25\text{m}$

2. A ball is thrown vertically upwards and reaches a maximum height of 31.25m.

Calculate;

- i) Initial velocity of the ball.
ii) The time taken to return to the hands of the thrower.

i)

At maximum height $H, v = 0\text{ms}^{-1}$
 $u = ?$ $g = -10\text{ms}^{-2}$ $H = 31.25\text{m}$
From $v^2 = u^2 + 2gs$
 $v^2 = u^2 + 2gH$
 $0^2 = u^2 + 2 \times -10 \times 31.25$
 $u^2 = 625$
 $u = \sqrt{625}$
 $u = 25\text{ms}^{-1}$

c)

From $v = u + gt$
 $0 = 25 + -10 \times t$
 $10t = 25$
 $t = \frac{25}{10}$
 $t = 2.5\text{s}$
Total time, $T = 2.5 \times 2$
 $T = 5\text{s}$

NOTE:

When a body is thrown vertically upwards the time taken to reach the maximum height is equal to the time taken for the body to fall back from maximum height to the point of projection.

3. A stone is released vertically downwards from the top of a tree and hits the ground after 3s.

Find

- i) the height of the tree.
ii) the velocity with which it hits the ground.

i)

$u = 0\text{ms}^{-1}$ $g = 10\text{ms}^{-2}$ $h = ?$ $t = 3\text{s}$
From $s = ut + \frac{1}{2}gt^2$
 $h = 0 \times 3 + \frac{1}{2} \times 10 \times 3^2$
 $h = \frac{90}{2}$
 $h = 45\text{m}$

ii)

From $v = u + gt$
 $v = 0 + 10 \times 3$
 $v = 30\text{ms}^{-1}$

4. A particle is thrown vertically upwards with a velocity of 20ms^{-1} from the edge of a cliff of height 10m. Calculate;
- the maximum height reached by the particle.
 - time taken to reach maximum height from the cliff top.
 - The total time taken by the particle to hit the ground

$$u = 20\text{ms}^{-1} \quad g = -10\text{ms}^{-2} \quad h = 10\text{m}$$

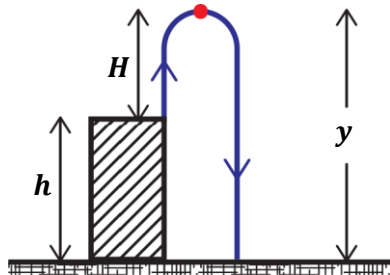

ii)

$$\text{From } v = u + gt$$

$$0 = 20 + -10 \times t_1$$

$$10t_1 = 20$$

$$t_1 = \frac{20}{10}$$

$$t_1 = 2\text{s}$$

i) At maximum height $v = 0\text{ms}^{-1}$

$$\text{From } v^2 = u^2 + 2gs$$

$$0^2 = 20^2 + 2 \times -10 \times H$$

$$20H = 400$$

$$H = \frac{400}{20}$$

$$H = 20\text{m}$$

iii)

$$\text{Total height, } y = h + H$$

$$\text{Total height, } y = 10 + 20 = 30\text{m}$$

Time taken to reach the ground

$$u = 0\text{ms}^{-1} \quad g = 10\text{ms}^{-2} \quad y = 30\text{m} = s$$

$$\text{From } s = ut + \frac{1}{2}gt^2$$

$$30 = 0 \times t_2 + \frac{1}{2} \times 10 \times t_2^2$$

$$t_2^2 = \frac{30}{5}$$

$$t_2 = \sqrt{6}$$

$$t_2 = 2.45\text{s}$$

$$\text{Time taken to reach the ground} = t_1 + t_2$$

$$= 2 + 2.45$$

$$= 4.45\text{s}$$

EXERCISE:

- A stone is thrown vertically upwards with a velocity of 15ms^{-1} . Calculate
 - the maximum height reached by the stone.
 - the time taken to reach maximum height.
- A body at a height of 20m above the ground falls freely under gravity to the ground. Calculate
 - the time taken by the body to reach the ground.
 - the velocity with which it hits the ground.
- An object is dropped from a helicopter. If the object hits the ground after 2s, calculate;
 - the height from which the object was dropped.
 - The velocity with which it hits the ground.

PROJECTILE MOTION

A projectile is an object which when given an initial velocity moves under the influence of force of gravity and it is only acted upon by its weight.

The path followed by a projectile is called **trajectory**.

If a projectile motion, a body's velocity consists of two parts i.e. horizontal velocity and vertical velocity.

- The horizontal velocity of the body remains the same throughout the motion since its not affected by the acceleration due to gravity.
- The vertical velocity of the body varies or changes since it is being affected by the acceleration due to gravity.

Therefore, the projectile will have both horizontal and vertical motion.

Consider a ball projected horizontally with an initial velocity $u\text{ms}^{-1}$ from the point above the ground.

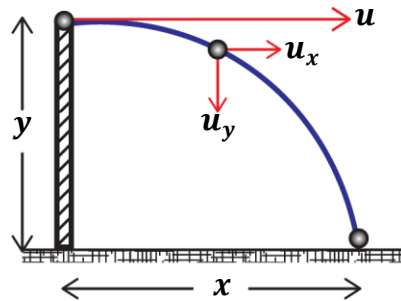

HORIZONTAL MOTION

$$a_x = 0\text{ms}^{-2} \quad u_x = u$$

$$\text{From } s = u_x t + \frac{1}{2} a_x t^2$$

$$x = ut + \frac{1}{2} \times 0 \times t^2$$

$$x = ut$$

VERTICAL MOTION

$$a_y = g\text{ms}^{-2} \quad u_y = 0$$

$$\text{From } s = u_y t + \frac{1}{2} a_y t^2$$

$$y = 0 \times t + \frac{1}{2} \times g \times t^2$$

$$y = \frac{1}{2} g t^2$$

Examples:

1. A ball is thrown from the edge of the cliff with a horizontal velocity 20ms^{-1} and hits the surface at a distance 60m from the base of the cliff.

Calculate;

- i) the time it takes to reach the surface.
- ii) the height of the cliff.

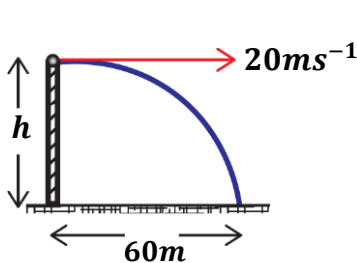

$$\text{i) } x = 60\text{m} \quad y = h \quad u = 20\text{ms}^{-1}$$

$$x = ut$$

$$60 = 20 \times t$$

$$t = \frac{60}{20}$$

$$t = 3\text{s}$$

$$\text{ii) } y = \frac{1}{2} g t^2$$

$$h = \frac{1}{2} \times 10 \times 3^2$$

$$h = \frac{90}{2}$$

$$h = 45\text{m}$$

2. An object is released from an aircraft horizontally with a velocity of 200ms^{-1} a height of 500m . Find
- how long it takes the object to reach the ground.
 - The horizontal distance covered by the object.

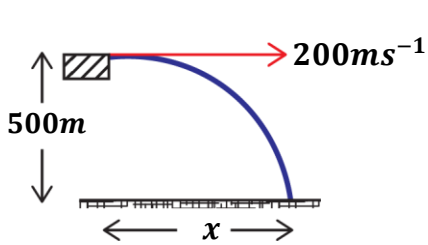

$$\begin{aligned} \text{i)} \quad y &= 500\text{m} \quad u = 200\text{ms}^{-1} \\ y &= \frac{1}{2}gt^2 \\ 500 &= \frac{1}{2} \times 10 \times t^2 \\ t^2 &= \frac{500}{5} \\ t &= \sqrt{100} \\ t &= 10\text{s} \end{aligned}$$

$$\begin{aligned} \text{ii)} \quad x &= ut \\ x &= 200 \times 10 \\ x &= 2000\text{m} \end{aligned}$$

3. A ball of mass 2kg is thrown horizontally with a speed of 15ms^{-1} from a top of a building. If it takes 2 seconds to reach the ground, find
- the height of the building.
 - the vertical velocity with which it hits the ground.
 - the kinetic energy of the ball before it hits the ground.

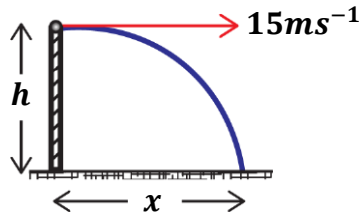

$$\begin{aligned} \text{i)} \quad m &= 2\text{kg} \quad y = h \quad u = 20\text{ms}^{-1} \quad t = 2\text{s} \\ y &= \frac{1}{2}gt^2 \\ h &= \frac{1}{2} \times 10 \times 2^2 \\ h &= \frac{40}{2} \\ h &= 20\text{m} \end{aligned}$$

$$\begin{aligned} \text{ii)} \quad u_y &= 0\text{ms}^{-1} \\ \text{From } v_y &= u_y + gt \\ v_y &= 0 + 10 \times 2 \\ v_y &= 20\text{ms}^{-1} \\ \text{OR} \\ P.E &= K.E \\ mgh &= \frac{1}{2}mv_y^2 \\ 2 \times 10 \times 20 &= \frac{1}{2} \times 2 \times v_y^2 \\ v_y^2 &= 400 \\ v_y &= \sqrt{400} \\ v_y &= 20\text{ms}^{-1} \end{aligned}$$

$$\begin{aligned} \text{iii)} \quad K.E &= \frac{1}{2}mv^2 \\ K.E &= \frac{1}{2} \times 2 \times 20^2 \\ K.E &= 400\text{J} \end{aligned}$$

MOTION GRAPHS FOR BODIES UNDER GRAVITY

The following graphs describe the motion of the body that has been thrown or projected vertically upwards.

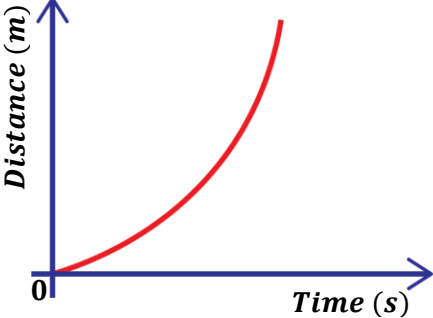
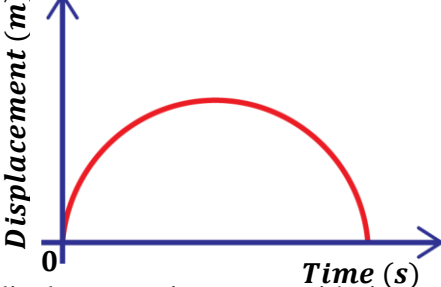
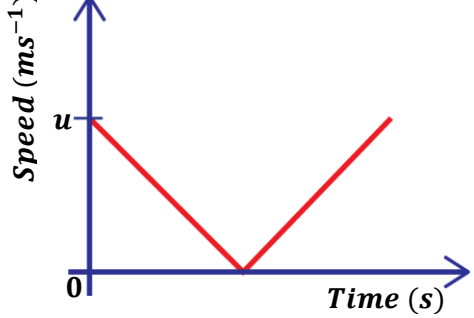
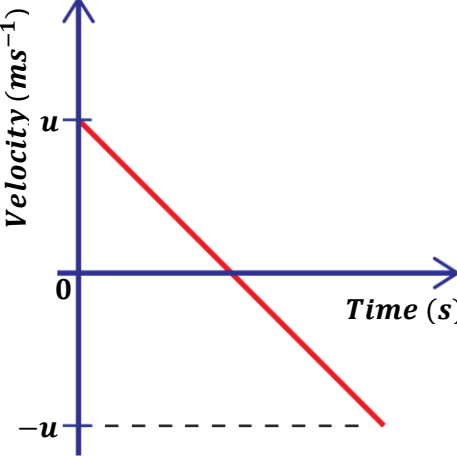
<p><u>Distance-time graph</u></p> 	<p><u>Displacement-time graph</u></p>  <p>The displacement increases with time and when the body reaches maximum height, it changes direction and start to move downwards</p>
<p><u>Speed-time graph</u></p>  <p>The speed of the body decreases as it goes higher. At maximum height the speed becomes $0ms^{-1}$ as the body rests momentarily. The speed increases as the body starts to fall down.</p>	<p><u>Velocity-time graph</u></p>  <p>The velocity of the body decreases as it goes higher until it reaches maximum height where velocity becomes $0ms^{-1}$. The velocity increases as the body starts to fall down. The negative velocity means that the body has changed direction.</p>

EXERCISE:

- A girl throws a ball horizontally from a window of a room onto the ground. If it takes the ball 4s to hit the ground, find
 - the vertical height from the point of projection to the ground.
 - the velocity with which the ball was projected given that it landed 50m away from the room.
- A stone is thrown horizontally with a velocity of $6ms^{-1}$ from the edge of the cliff 125m tall. Find how far the stone landed from the bottom of the cliff.
- A bomb is released from a plane 5000m high with a velocity $30ms^{-1}$. Find the
 - time it takes to reach the ground.
 - horizontal distance it covers by the time it hits the ground.

4. A jet flying at a height of 2km with a horizontal velocity of 40m/s drops a bomb to hit a target. Determine
 - a) the time taken before the bomb hits the ground.
 - b) the vertical velocity with which it hits the ground.
 - c) the horizontal distance covered by the bomb by the time it hits the ground.

5. A bomb is released from a jet fighter plane moving with a velocity of 400ms^{-1} to hit a rebel camp in northern Uganda. If the bomb took 10 seconds to hit the target, calculate;
 - i) the altitude at which the bomb was released.
 - ii) the horizontal distance from the vertical point of the jet fighter plane to the target.
 - iii) the velocity with which the bombs hits the target.
 - iv) The kinetic energy of the bomb before hitting the target.

Experiment to determine acceleration due to gravity using a simple pendulum

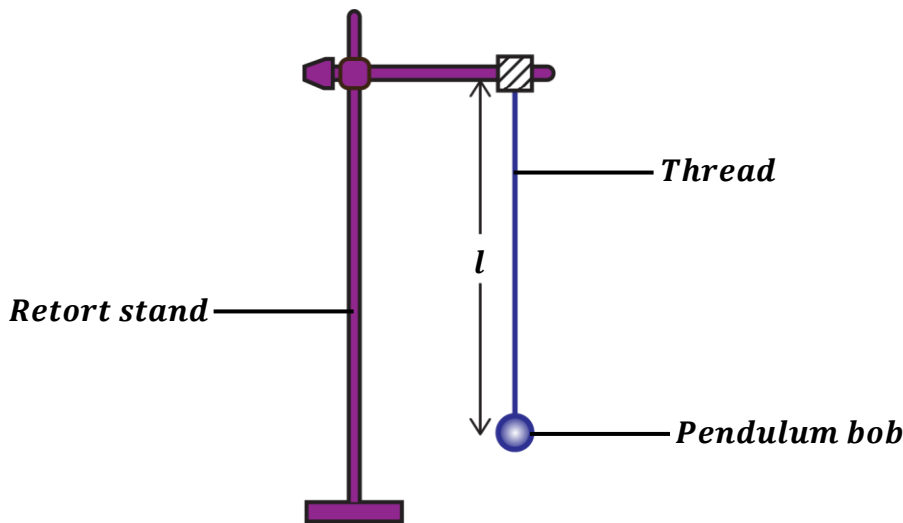

- Suspend a pendulum bob from a retort stand using a small piece of thread as shown in the diagram above.
- Starting with length, $l = 20\text{cm}$, displace the pendulum bob through a small angle and release it to oscillate.
- Measure the time, t for 20 oscillations of the pendulum bob using a stop clock.
- Determine time, T for one oscillation i.e. $T = \frac{t}{20}$
- Repeat the experiment for other increasing values of l .
- Record the results in a suitable table including values of T^2 .

$l(\text{m})$	$t(\text{s})$	$T(\text{s})$	$T^2(\text{s}^2)$

- Plot a graph of T^2 against l and determine its slope, S .

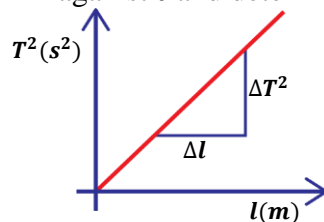

$$S = \frac{\Delta T^2}{\Delta l}$$

- Determine the acceleration due to gravity, g from $g = \frac{4\pi^2}{S}$

TICKER-TIMER

A ticker-timer is an electric device used in a physics laboratory to study speed, velocity and acceleration of the body.

It consists of a vibrating arm which vibrates due to the changing current (alternating current) applied to it. As it vibrates, it prints dots on a ticker-tape which is pulled through it. The dots printed are used to study the motion of the body.

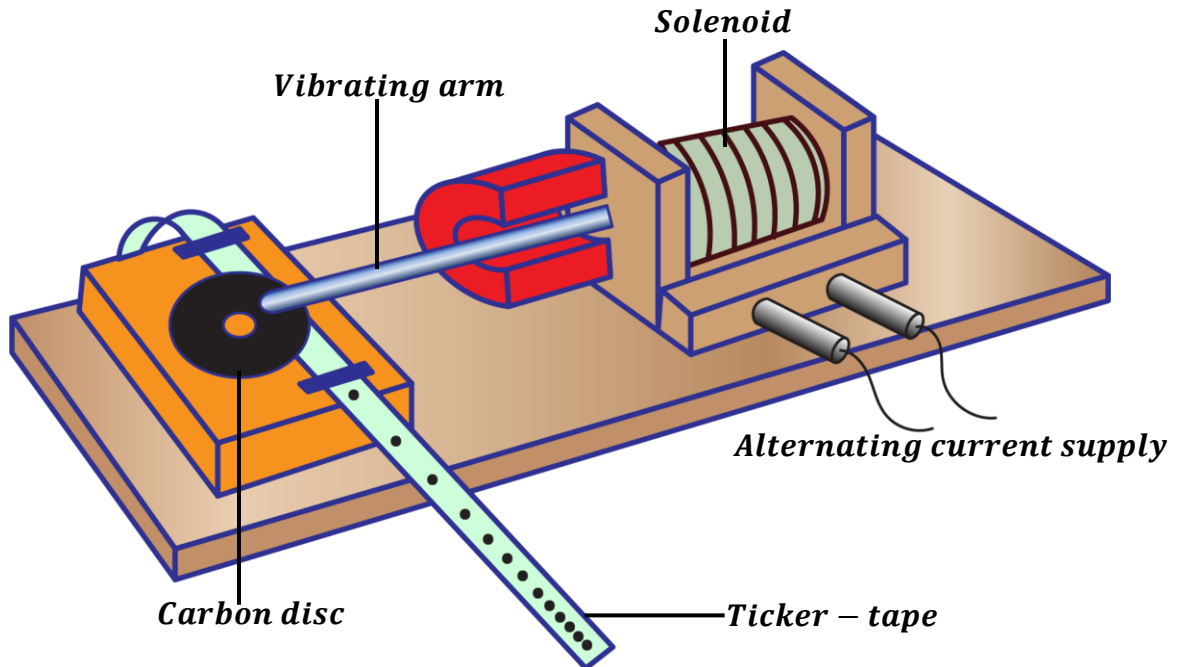

Experiment to determine uniform velocity of a body using a ticker-timer.

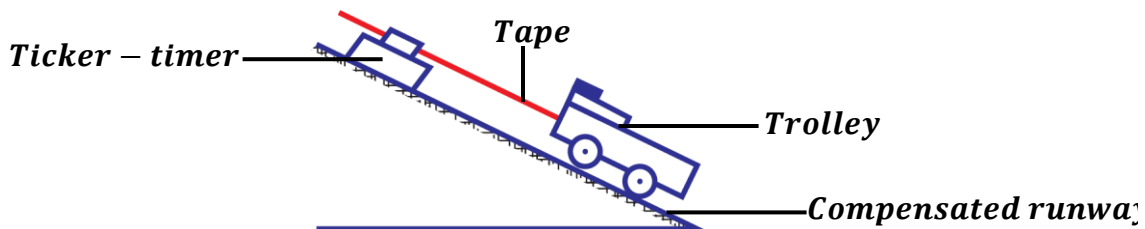

- The ticker-tape is tied on a trolley placed on a tilted (inclined) runway.
- The ticker-timer is switched on and a vibrating arm of known frequency, f moves the pin up and down.
- The time taken for one complete vibration (periodic time) is determined from $T = \frac{1}{f}$
- The trolley is slightly pushed to make it run on the inclined runway.
- The ticker-tape is pulled with uniform velocity such that the dots printed are equally spaced.
- The tape with printed dots is removed from the trolley.
- The distance covered by a certain number of dots is measured and noted.

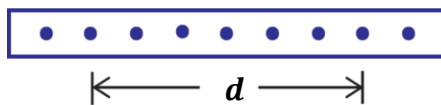

- Uniform velocity is then calculated from; $\text{Uniform velocity} = \frac{\text{Distance covered } (d)}{\text{Time taken}}$

where Time taken = periodic time (T) \times number of spaces

NOTE:

Before the experiment, its necessary to compensate for friction. This can be done by tilting the runway until a certain point is reached such that when a trolley is given a slight push, it moves with uniform velocity.

Important definitions:
❖ Frequency, f:

This is the number of number of dots printed per second.

OR

This is the number of vibrations per second.

The SI unit of frequency is Hertz (**Hz**)

❖ Period (Tick), T:

This is time taken to print any two successive dots on the tape.

Its SI unit is a second (s).

How to calculate velocity:

- First note the distance between the reference dots.

- Find the period from $T = \frac{1}{f}$

- Find the time taken to print the reference dots from;

Time taken = Period (T) × number of spaces between the reference dots

Time taken = $\frac{1}{f} \times$ number of spaces between the reference dots

- Then speed or velocity = $\frac{\text{Distance covered}}{\text{Time taken}}$

Examples:

1. The figure below is a tape which was pulled through a ticker- timer of frequency 50Hz.

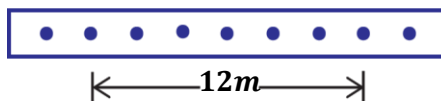

Find

- i) the period.
- ii) time taken to print the reference dots.
- iii) the speed at which a tape is pulled.

i)

$$d = 12m, \quad f = 50Hz$$

$$\text{Period, } T = \frac{1}{f}$$

$$T = \frac{1}{50}$$

$$T = 0.02s$$

ii)

Time taken, t = period × number of spaces

$$t = 0.02 \times 6$$

$$t = 0.12s$$

iii)

$$\text{Speed} = \frac{\text{Distance (d)}}{\text{Time taken (t)}}$$

$$V = \frac{12}{0.12}$$

$$V = 100ms^{-1}$$

2. A ticker-timer vibrates at a frequency of 50Hz. If the distance between two consecutive dots is 2cm. Find the time that elapses between two consecutive and average speed of the tape.

$$d = 2\text{cm}, \quad f = 50\text{Hz}$$

Periodic time

$$\text{Period, } T = \frac{1}{f}$$

$$T = \frac{1}{50}$$

$$T = 0.02\text{s}$$

Average speed

$$\text{Time taken, } t = T \times \text{number of spaces}$$

$$t = \frac{1}{f} \times \text{no. of spaces}$$

$$t = \frac{1}{50} \times 1$$

$$t = 0.02\text{s}$$

OR

$$V = \frac{\text{Distance } (d)}{\text{Time taken } (t)}$$

$$V = \frac{2}{0.02}$$

$$V = 100\text{cms}^{-1}$$

$$\text{Speed} = \frac{\text{Distance } (d)}{\text{Time taken } (t)}$$

$$V = \frac{2/100}{0.02}$$

$$V = 1\text{ms}^{-1}$$

3. The ticker tape below was pulled through a ticker-time of frequency 50Hz. Calculate the speed at which the tape was pulled.

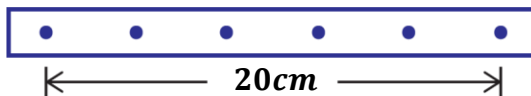

$$f = 50\text{Hz}, \quad d = 20\text{cm} = \frac{20}{100} = 0.2\text{m}$$

$$\text{Time taken, } t = \text{period} \times \text{number of spaces}$$

$$t = \frac{1}{f} \times \text{number of spaces}$$

$$t = \frac{1}{50} \times 5$$

$$t = 0.1\text{s}$$

$$\text{Speed} = \frac{\text{Distance } (d)}{\text{Time taken } (t)}$$

$$V = \frac{0.2}{0.1}$$

$$V = 2\text{ms}^{-1}$$

4. The ticker-tape shown below was pulled through a ticker-timer which makes 100 dots every second.

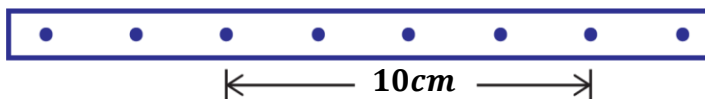

Find the speed at which the tape is pulled.

$$f = 100\text{Hz}, \quad d = 10\text{cm} = \frac{10}{100} = 0.1\text{m}$$

$$\text{Time taken, } t = \text{period} \times \text{number of spaces}$$

$$t = \frac{1}{f} \times \text{number of spaces}$$

$$t = \frac{1}{100} \times 4$$

$$t = 0.04\text{s}$$

$$\text{Speed} = \frac{\text{Distance } (d)}{\text{Time taken } (t)}$$

$$V = \frac{0.1}{0.04}$$

$$V = 2.5\text{ms}^{-1}$$

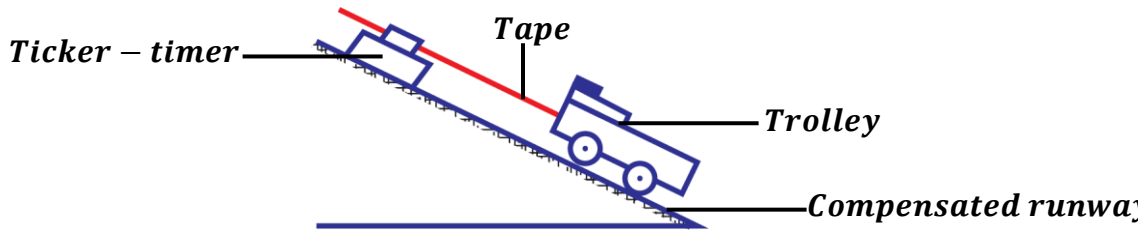
Experiment to determine acceleration of a body using a ticker-timer.

- The ticker-tape is tied on a trolley placed on a tilted (inclined) runway.
- The ticker-timer is switched on and a vibrating arm of known frequency, f moves the pin up and down.
- The time taken for one complete vibration (periodic time) is determined from $T = \frac{1}{f}$
- The trolley is slightly pushed to make it run on the inclined runway.
- The ticker-tape is pulled through the ticker-timer such that the dots are printed on it as shown below.

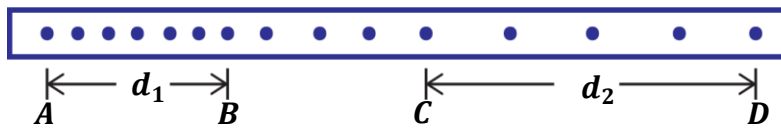

- The distances d_1 and d_2 covered by the selected number of dots is measured and noted.
- If there are n_1 spaces between region **AB**, then the time taken to print them is Tn_1 .
- The initial velocity, u is then calculated from; $u = \frac{d_1}{Tn_1}$
- If there are n_2 spaces between region **CD**, then the time taken to print them is Tn_2 .
- The final velocity, v is then calculated from $v = \frac{d_2}{Tn_2}$
- The acceleration of the trolley can be calculated from $a = \frac{v - u}{t}$

where t = time taken from the mid point of **AB** to mid point of **CD**

How to calculate acceleration:

- First note the distances between the reference dots.
- Find the period from $T = \frac{1}{f}$
- Find the times taken t_1 and t_2 to print the reference dots from;
Time taken = Period (T) × number of spaces between the reference dots
Time taken = $\frac{1}{f} \times$ number of spaces between the reference dots

- Calculate the initial velocity, u and final velocity, v from;

$$u = \frac{d_1}{t_1} \quad v = \frac{d_2}{t_2}$$

- Calculate the acceleration of the trolley from $a = \frac{v - u}{t}$

NOTE: To calculate time taken, t , the spaces are measured from middle of initial distance to the middle of final distance.

Examples:

1. The figure below shows dots printed by a ticker-timer of frequency 100Hz, calculate the acceleration of the ticker-tape.

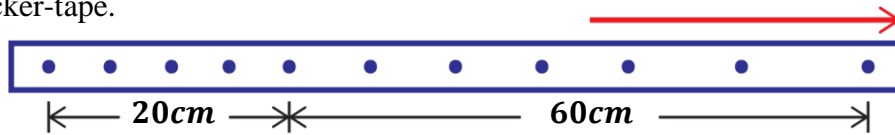
Initial velocity

$$d_1 = 20\text{cm} = \frac{20}{100} = 0.2\text{m}$$

$$f = 100\text{Hz}, n_1 = 4\text{spaces}$$

$$t_1 = \text{period} \times \text{number of spaces}$$

$$t_1 = \frac{1}{f} \times n_1$$

$$t_1 = \frac{1}{100} \times 4$$

$$t_1 = 0.04\text{s}$$

$$u = \frac{d_1}{t_1}$$

$$u = \frac{0.2}{0.04}$$

$$u = 5\text{ms}^{-1}$$

Final velocity

$$d_2 = 60\text{cm} = \frac{60}{100} = 0.6\text{m}$$

$$f = 100\text{Hz}, n_2 = 6\text{spaces}$$

$$t_2 = \text{period} \times \text{number of spaces}$$

$$t_2 = \frac{1}{f} \times n_2$$

$$t_2 = \frac{1}{100} \times 6$$

$$t_2 = 0.06\text{s}$$

$$v = \frac{d_2}{t_2}$$

$$v = \frac{0.6}{0.06}$$

$$v = 10\text{ms}^{-1}$$

Acceleration

$$n = 5\text{spaces}$$

$$t = \frac{1}{f} \times n$$

$$t = \frac{1}{100} \times 5$$

$$t = 0.05\text{s}$$

$$a = \frac{v - u}{t}$$

$$a = \frac{10 - 5}{0.05}$$

$$a = \frac{5}{0.05}$$

$$a = 100\text{ms}^{-2}$$

2. The figure below shows dots printed by a ticker-timer. If the ticker-timer prints 100 dots per second, calculate the acceleration of the tape pulled through it.

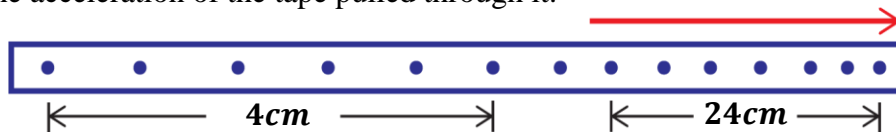
Initial velocity

$$d_1 = 4\text{cm} = \frac{40}{100} = 0.4\text{m}$$

$$f = 100\text{Hz}, n_1 = 5\text{spaces}$$

$$t_1 = \text{period} \times \text{number of spaces}$$

$$t_1 = \frac{1}{f} \times n_1$$

$$t_1 = \frac{1}{100} \times 5$$

$$t_1 = 0.05\text{s}$$

$$u = \frac{d_1}{t_1}$$

$$u = \frac{0.4}{0.05}$$

$$u = 8\text{ms}^{-1}$$

Final velocity

$$d_2 = 24\text{cm} = \frac{24}{100} = 0.24\text{m}$$

$$f = 100\text{Hz}, n_2 = 6\text{spaces}$$

$$t_2 = \text{period} \times \text{number of spaces}$$

$$t_2 = \frac{1}{f} \times n_2$$

$$t_2 = \frac{1}{100} \times 6$$

$$t_2 = 0.06\text{s}$$

$$v = \frac{d_2}{t_2}$$

$$v = \frac{0.24}{0.06}$$

$$v = 4\text{ms}^{-1}$$

Acceleration

$$n = 7.5\text{spaces}$$

$$t = \frac{1}{f} \times n$$

$$t = \frac{1}{100} \times 7.5$$

$$t = 0.075\text{s}$$

$$a = \frac{v - u}{t}$$

$$a = \frac{4 - 8}{0.075}$$

$$a = \frac{-4}{0.075}$$

$$a = -53.3\text{ms}^{-2}$$

NOTE:

The ticker-tapes below shows the dots printed for bodies in motion.

- ❖ If the body is moving with **constant or uniform velocity**, the dots are equally spaced along the tape.



- ❖ If the body is moving with **uniform acceleration**, the spacing between the dots increase progressively.



- ❖ If the body is moving with **uniform deceleration**, the spacing between the dots decrease progressively.

Further examples:

3. The figure below shows a tape produced by a ticker-timer operating at a frequency of 50Hz.

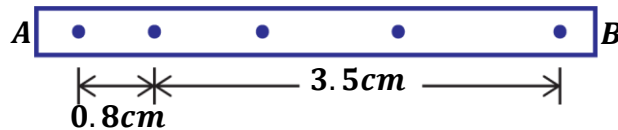

If the body or trolley was uniformly decelerating,

a) In which direction was it moving?

It was moving from B to A since spacing of the dots reduce progressively from B to A.

b) Calculate the deceleration of the trolley that pulled the tape through the ticker timer.

Initial velocity

$$d_1 = 3.5\text{cm} = \frac{3.5}{100} = 0.035\text{m}$$

$$f = 50\text{Hz}, n_1 = 3\text{spaces}$$

$t_1 = \text{period} \times \text{number of spaces}$

$$t_1 = \frac{1}{f} \times n_1$$

$$t_1 = \frac{1}{50} \times 3$$

$$t_1 = 0.06\text{s}$$

$$u = \frac{d_1}{t_1}$$

$$u = \frac{0.035}{0.06} = 0.58\text{ms}^{-1}$$

Final velocity

$$d_2 = 0.8\text{cm} = \frac{0.8}{100} = 0.008\text{m}$$

$$f = 50\text{Hz}, n_2 = 1\text{space}$$

$t_2 = \text{period} \times \text{number of spaces}$

$$t_2 = \frac{1}{f} \times n_2$$

$$t_2 = \frac{1}{50} \times 1$$

$$t_2 = 0.02\text{s}$$

$$v = \frac{d_2}{t_2}$$

$$v = \frac{0.008}{0.02} = 0.4\text{ms}^{-1}$$

Acceleration

$$n = 2\text{spaces}$$

$$t = \frac{1}{f} \times n$$

$$t = \frac{1}{50} \times 2$$

$$t = 0.04\text{s}$$

$$a = \frac{v - u}{t}$$

$$a = \frac{0.4 - 0.58}{0.04}$$

$$a = \frac{-0.18}{0.04}$$

$$a = -4.5\text{ms}^{-2}$$

4. A trolley is pulled from rest with a constant force down an inclined plane. The trolley pulls a tape through a ticker-timer vibrating at 50Hz. The following measurements were made as follows.

Distance between 16th dot and 20th dot = 20cm

Distance between 40th dot and 50th dot = 62cm

Calculate the acceleration of the trolley.

Initial velocity

$$d_1 = 20\text{cm} = \frac{20}{100} = 0.2\text{m}$$

$$f = 50\text{Hz},$$

$$n_1 = n^{\text{th}} - m^{\text{th}}$$

$$n_1 = 20 - 16 = 4\text{spaces}$$

$$t_1 = \text{period} \times \text{number of spaces}$$

$$t_1 = \frac{1}{f} \times n_1$$

$$t_1 = \frac{1}{50} \times 4$$

$$t_1 = 0.08\text{s}$$

$$u = \frac{d_1}{t_1}$$

$$u = \frac{0.2}{0.08} = 2.5\text{ms}^{-1}$$

Final velocity

$$d_2 = 62\text{cm} = \frac{62}{100} = 0.62\text{m}$$

$$f = 50\text{Hz},$$

$$n_2 = n^{\text{th}} - m^{\text{th}}$$

$$n_2 = 50 - 40 = 10\text{spaces}$$

$$t_2 = \text{period} \times \text{number of spaces}$$

$$t_2 = \frac{1}{f} \times n_2$$

$$t_2 = \frac{1}{50} \times 10$$

$$t_2 = 0.2\text{s}$$

$$v = \frac{d_2}{t_2}$$

$$v = \frac{0.62}{0.2} = 3.1\text{ms}^{-1}$$

Acceleration

Spaces in between

$$n_3 = n^{\text{th}} - m^{\text{th}}$$

$$n_3 = 40 - 20 = 20$$

$$n = 2 + n_3 + 5$$

$$n = 27\text{spaces}$$

$$t = \frac{1}{f} \times n$$

$$t = \frac{1}{50} \times 27$$

$$t = 0.54\text{s}$$

$$a = \frac{v - u}{t}$$

$$a = \frac{3.1 - 2.5}{0.54}$$

$$a = \frac{0.6}{0.54}$$

$$a = 1.11\text{ms}^{-2}$$

5. The figure below shows a tape pulled by a trolley through a ticker-timer. Describe the motion of the trolley if the frequency of the timer is 50Hz.

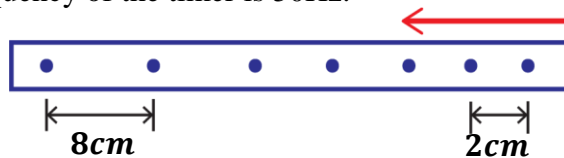

Initial velocity

$$d_1 = 2\text{cm} = \frac{2}{100} = 0.02\text{m}$$

$$f = 50\text{Hz}, n_1 = 1\text{space}$$

$$t_1 = \text{period} \times \text{number of spaces}$$

$$t_1 = \frac{1}{f} \times n_1$$

$$t_1 = \frac{1}{50} \times 1$$

$$t_1 = 0.02\text{s}$$

$$u = \frac{d_1}{t_1}$$

$$u = \frac{0.02}{0.02} = 1\text{ms}^{-1}$$

Final velocity

$$d_2 = 8\text{cm} = \frac{8}{100} = 0.08\text{m}$$

$$f = 50\text{Hz}, n_2 = 1\text{space}$$

$$t_2 = \text{period} \times \text{number of spaces}$$

$$t_2 = \frac{1}{f} \times n_2$$

$$t_2 = \frac{1}{50} \times 1$$

$$t_2 = 0.02\text{s}$$

$$v = \frac{d_2}{t_2}$$

$$v = \frac{0.08}{0.02} = 4\text{ms}^{-1}$$

Acceleration

$$n = 5\text{spaces}$$

$$t = \frac{1}{f} \times n$$

$$t = \frac{1}{50} \times 5$$

$$t = 0.1\text{s}$$

$$a = \frac{v - u}{t}$$

$$a = \frac{4 - 1}{0.1}$$

$$a = \frac{3}{0.1}$$

$$a = 30\text{ms}^{-2}$$

In the first $0.02s$, the trolley was moving with a speed of $1ms^{-1}$. It accelerated uniformly at a rate of $30ms^{-2}$ to a final velocity of $4ms^{-1}$ in the last $0.02s$.

EXERCISE:

1. A tape was pulled through a ticker-timer which made one dot every second. If it made three dots and the distance between the three dots is $16cm$, find the velocity of the tape.
2. A paper tape was attached to a moving trolley and allowed to run through a ticker-timer. The figure below shows a section of the tape.

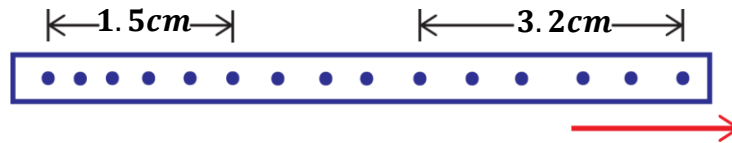

If the frequency of the tape is $100Hz$, determine;

- i) initial and final velocities of the trolley.
 - ii) average acceleration of the trolley.
3. In a ticker-timer experiment, the distance occupied by a 6-dot space on the tape is $5.1cm$, while the adjacent 6-dot space occupies $6.3cm$. Find the acceleration of the body to which the tape is attached, if the ticker frequency is $50Hz$.
 4. The figure below shows a tape that was pulled through a ticker-timer of frequency $50Hz$.

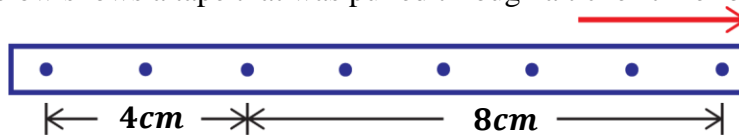

Describe the motion of the body pulling the tape.

5. The figure below shows dots produced on a tape pulled through a ticker-timer by a moving body.



- a) State the type of motion in the figure above.
 - b) Calculate the acceleration of the moving body.
6. A paper tape dragged through a ticker timer by a trolley has the first ten dots covering a distance of $4cm$ and the next ten dots covering a distance of $7cm$. if the frequency of the ticker-timer is $50Hz$, calculate the acceleration of the trolley.
 7. The distance between the 15th dot and the 18th dot is $10cm$. If the ticker-timer is vibrating at $20Hz$. Calculate the:
 - i) time taken to print the dots.
 - ii) average speed of the tape.
 8. The figure below shows a piece of tape pulled through a ticker-timer by a trolley down an inclined plane. The frequency of the ticker-timer is $50Hz$.

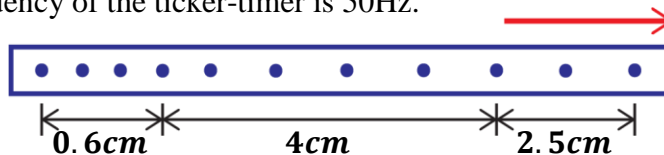

Calculate the acceleration of the trolley.

CIRCULAR MOTION

Circular motion is the motion in which a body moves in a circle about a fixed point.

In circular motion;

- ❖ The speed of the body is always constant.
- ❖ The direction of the body is always changing.
- ❖ The velocity of the body keeps on changing due to the changing direction. This is because velocity is a vector quantity which depends on the direction.
- ❖ The body has an acceleration due to the changing velocity. This acceleration (centripetal acceleration) acts towards the centre of the circle.

TERMS USED IN CIRCULAR MOTION

The figure below shows a whirled body tied on the string.

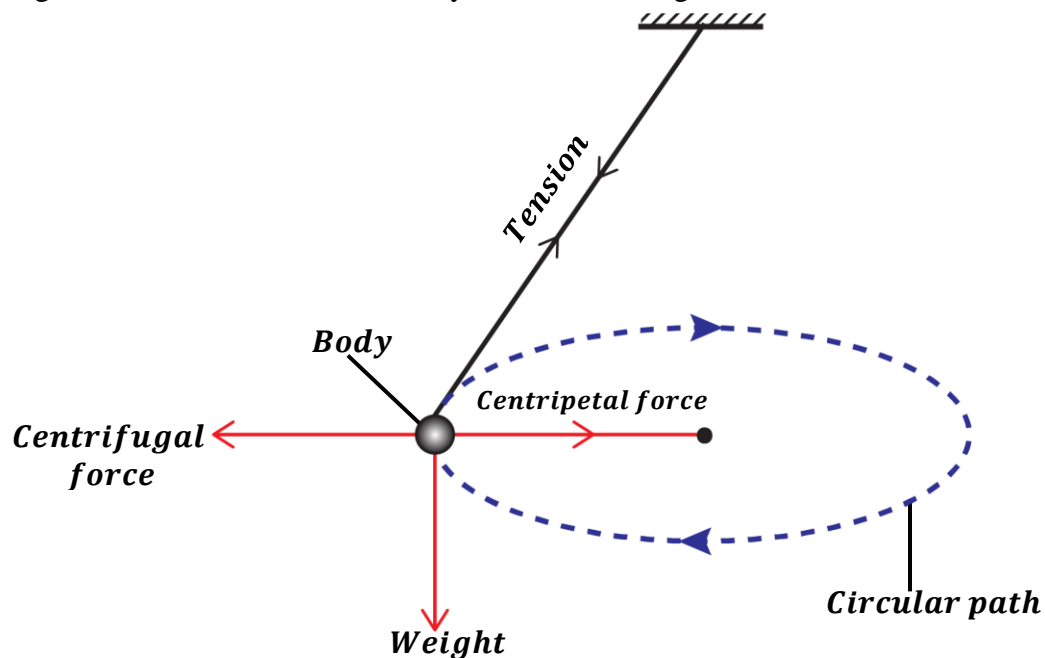

Tension:

This is the force exerted by a string on the body moving in circular motion. The tension force provides the centripetal force.

Centripetal force:

This is the force acting on the body towards the centre of the circular path.

Centripetal acceleration:

This is the acceleration that acts on a body towards the centre of the circular path. It is provided by the centripetal force.

Centrifugal force:

This is the force acting on the body away from the centre of the circular path.

Weight:

This is the force acting on the body vertically downwards towards the centre of the earth.

NOTE:

Experimental results show that the force required to keep the body moving in a circular path i.e.

centripetal force increases with;

- i) an increase in the mass of the body.
- ii) an increase in the speed of the body.
- iii) a decrease in radius of the circular path.

APPLICATION OF CIRCULAR MOTION IN REAL LIFE SITUATION**Bending of a cyclist round a curve:**

A cyclist going round a curve has to lean inwards (bend slightly towards the centre of circular path) in order to take a safe turn without slipping. This slight bending provides the necessary centripetal force so as to be able to go along the curved track.

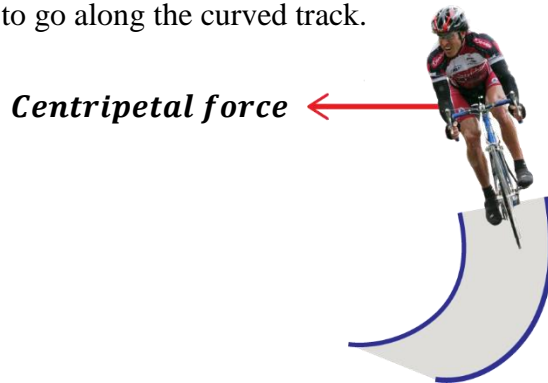
**Banking of tracks:**

When a car is going round a circular path, the centripetal force required to keep the car in circular motion is provided by the frictional force between the tyres and the road. This centripetal force prevents the car from sliding even if it is moving fast.

In order for a car not to fully depend on the frictional force, the circular paths are given a small banking i.e. the outer edge of the road is slightly raised above the inner surface. This helps to increase the centripetal force required for a body not to slide.

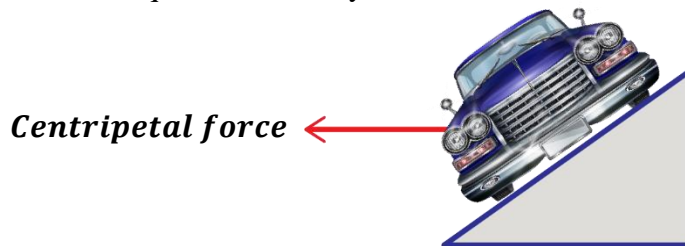
**Other examples or applications of circular motion include;**

- A stone tied to one end of a string and the other end is rotated about a fixed point.
- An aircraft (plane) making a circular turn.
- Planets or satellites orbiting the earth.
- Electrons orbiting the nucleus.
- Centrifuge used to separate liquids of different densities.
- Washing machines for clothes.

EXERCISE:

1. A stone attached to a string is swung in a vertical circular path in air as shown in the figure below.

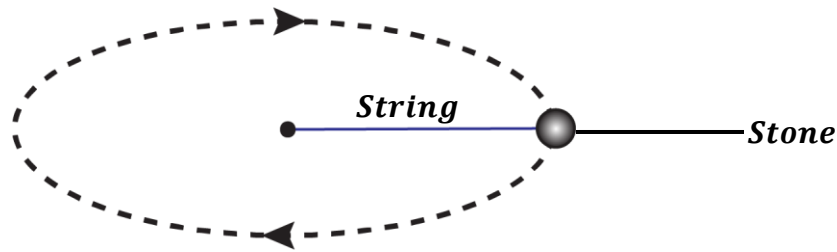

- a) Copy the above diagram and on it indicate all the forces acting on the body.
 - b) Describe all the forces indicated above.
- 2.
- a) Define the term centripetal force.
 - b) Explain how a cyclist avoids slipping off the road when moving round a circular path.
 - c) State five applications of circular motion in daily life situations.

NEWTON'S LAWS OF MOTION

Sir Isaac Newton carried out very many experiments and through these experiments, he formulated three laws that relate the **forces** acting on the body and the **motion** of the body. These laws are known as *Newton's laws of motion*.

❖ Newton's first law of motion:

It states that every body continues in its state of rest or uniform motion in a straight line unless acted upon by an external force.

The first is also referred to as the “**law of inertia.**”

INERTIA:

This is the tendency of a body at rest to remain at rest or to continue moving in a straight if it was already moving.

OR

This is the reluctance of a body to start moving or stop moving if it was already moving.

Factors affecting inertia of a body:**a) Mass of a body:**

A body with a large mass requires a large force to make it move and it requires a large force to stop it if it was already moving. Hence a body with a large mass has a greater inertia.

b) Force applied on a body:

When the force applied on a body is increased, its tendency to remain at rest is also reduced. This would result to movement of the body from its resting state. Thus, a large force applied on the body reduces its inertia.

c) Friction acting on a body:

The law of inertia states that a body will continue in its state of rest or uniform motion in a straight line unless acted upon by an external force. An example of such a force is the friction force. This force will slow down the motion of the body even though it is moving fast.

Examples or applications of Newton's first law of motion:

- A person riding a bicycle along a level road does not come to rest immediately when he or she stops pedaling i.e. the bicycle continues to move forward for sometime and eventually comes to rest.
Due to inertia, the bicycle continues to move forward for sometime until it is acted upon by an external force such a friction between the tyre and the surface of the road which brings it to rest.
- Passengers in a fast-moving vehicle jerk forward when the vehicle tops suddenly and jerk backward when the vehicle starts moving.
For this reason, passengers are advised to fasten their safety belts when in a vehicle. The seat belts hold passengers onto their seats in case of any sudden stopping. This helps them to avoid getting injuries as a result of jerking forward and hitting the wind screen.

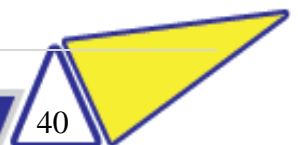

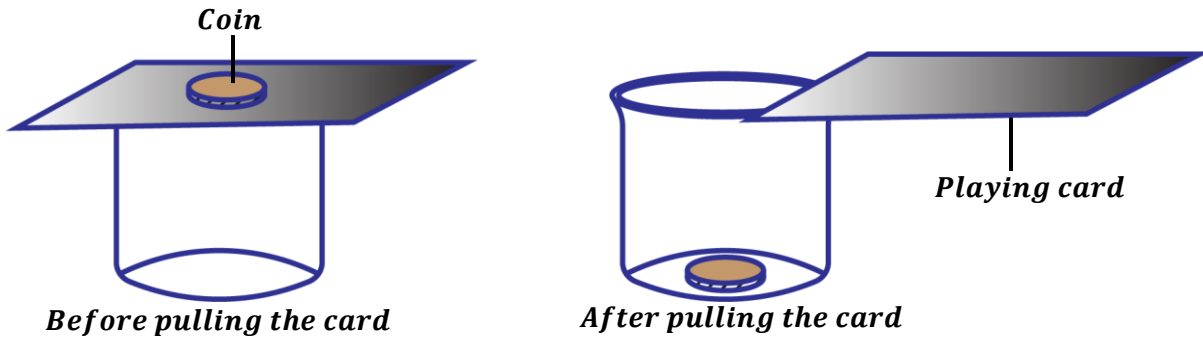
Demonstration of Newton's first law of motion:

- Place a playing card on top of a beaker.
- Put a coin on top of the playing card.
- Pull the card quickly towards you or hit the card out with a sharp flick.

Observation:

It is observed that the coin drops into the beaker.

Explanation:

The coin has inertia meaning that it doesn't change its state of rest when the card is quickly pulled. So, it just drops vertically into the beaker at the same position.

Pulling the card quickly provides a large force to overcome the friction force between the card and the coin.

NOTE: If the card is pulled away at a slow pace, the coin will move together with the card. This is because pulling it slowly provides a less force to overcome the friction force between the card and the coin.

❖ Newton's second law of motion:

It states that the rate of change of momentum of a body is directly proportional to the applied force and it takes place in the direction of force.

Mathematically;

$$\text{Force} \propto \text{Rate of change of momentum}$$

$$\text{Force} \propto \frac{\text{Change of momentum}}{\text{Time}}$$

$$\text{Force} \propto \frac{\text{Final momentum} - \text{Initial momentum}}{\text{Time}}$$

$$\text{Final momentum} = \text{mass} \times \text{final velocity} = mv$$

$$\text{Final momentum} = \text{mass} \times \text{initial velocity} = mu$$

$$F \propto \frac{mv - mu}{t}$$

$$F \propto \frac{m(v - u)}{t}$$

$$\text{But } a = \frac{(v - u)}{t}$$

$$F \propto ma$$

$$F = kma$$

where k is a constant of proportionality

If $F = 1\text{N}$, $m = 1\text{kg}$, $a = 1\text{ms}^{-2}$ then $k = 1$

$$\boxed{F = ma}$$

NOTE:

The SI unit of force is a Newton (N).

A **Newton** is the force which gives a mass of 1kg an acceleration of 1ms^{-2} .

Examples:

1. An object of mass 4kg accelerates at a rate of 5ms^{-2} . Calculate the resultant force acting on it.

$$m = 4\text{kg}, \quad a = 5\text{ms}^{-2}$$

$$F = ma$$

$$F = 4 \times 5$$

$$F = 20\text{N}$$

2. Calculate the acceleration produced by a force of 25N on an object of mass 2tonnes .

$$m = 2\text{tonnes} = (2 \times 1000) = 2000\text{kg}, \quad F = 25\text{N}$$

$$F = ma$$

$$25 = 2000 \times a$$

$$a = \frac{25}{2000}$$

$$a = 0.0125\text{ms}^{-2}$$

3. A resultant force of 40N acts on a body of 500g initially at rest for 4s . Calculate

i) acceleration on the body.

ii) final velocity of the body.

i)

$$m = 500\text{g} = \frac{500}{1000} = 0.5\text{kg}, \quad F = 40\text{N}$$

$$F = ma$$

$$40 = 0.5 \times a$$

$$a = \frac{40}{0.5}$$

$$a = 80\text{ms}^{-2}$$

ii)

$$u = 0\text{ms}^{-1}, \quad t = 4\text{s}$$

$$v = u + at$$

$$v = 0 + 80 \times 4$$

$$v = 320\text{ms}^{-1}$$

4. Two forces of 3N and 4N act on the object of mass 2kg as shown below. Find the acceleration of the body.

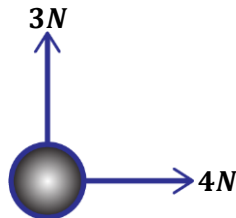

Resultant force

$$F^2 = F_1^2 + F_2^2$$

$$F^2 = 3^2 + 4^2$$

$$F^2 = 25$$

$$F = \sqrt{25}$$

$$F = 5\text{N}$$

$$F = ma$$

$$5 = 2 \times a$$

$$a = \frac{5}{2}$$

$$a = 2.5\text{ms}^{-2}$$

Examples or applications of Newton's second law of motion:

In Newton's second law acceleration depends on two variables i.e. the net force acting on the body and the mass of the body.

$$a = \frac{F}{m}$$

Therefore, acceleration is directly proportional to force acting on the body and inversely proportional to mass of the body. This means an increase in force increases the acceleration of the body and an increase in mass reduces the acceleration of the body.

The following are some of daily-life applications of Newton's second law of motion.

- When playing football, the stronger the ball is kicked, the more the increase in velocity it will move with. This is because a stronger kick increases the force acting on the ball thus increasing its acceleration.
- When in a supermarket, it's easier to push an empty cart than to push a loaded one. This is because the loaded cart has more mass thus a decrease in its acceleration. So, it will require a large force to accelerate it any further.
- Among two people walking, if one is heavier than the other one, the heavier person will walk slower than the lighter person.
- In formula one racing, the mass of the cars is kept as low as possible. This implies that low mass will increase their acceleration.

❖ Newton's third law of motion:

It states that for every action, there is an equal and opposite reaction.

Consider a ball placed on the table as shown below;

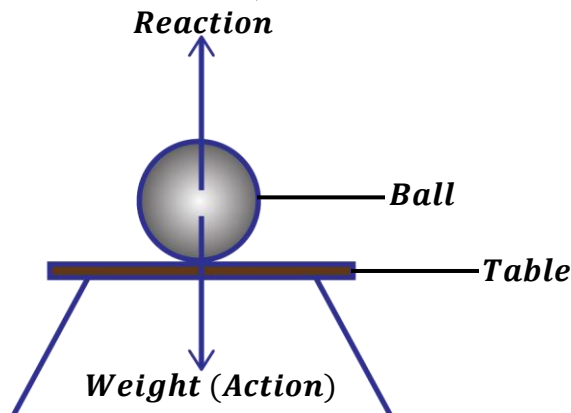

The ball exerts a force equal to its weight onto the table. This force is called an **action**.

At the same time, the table exerts an equal force on the ball but the force acts in an opposite direction.

This force is called a **reaction**.

NOTE:

Since **weight, $W = mg$**

Then also, **reaction, $R = mg$**

Applications of Newton's third law of motion:
MOTION IN A LIFT (ELEVATOR)

When a body of mass, m is placed on the floor of a lift which is moving with an acceleration, ams^{-2} , it exerts its weight onto the floor of the lift. At the same time the, lift exerts a reaction force in an opposite direction.

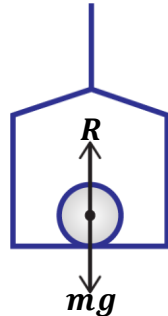
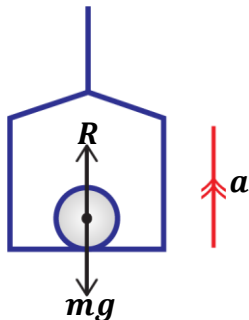
a) If the lift is moving upwards:

Resultant force, $F = ma$

$$R - mg = ma$$

$$R = mg + ma$$

$$R = m(g + a)$$

The Reaction (Apparent weight of the body), \mathbf{R} is greater than the actual weight of the body.

- This explains why a person standing in a lift feels heavier when the lift is moving upwards.

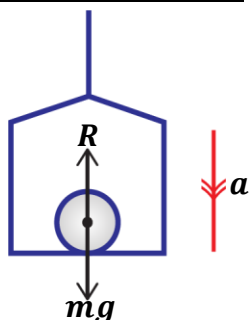
b) If the lift is moving downwards:

Resultant force, $F = ma$

$$mg - R = ma$$

$$R = mg - ma$$

$$R = m(g - a)$$

The Reaction (Apparent weight of the body), \mathbf{R} is less than the actual weight of the body.

- This explains why a person standing in a lift feels lighter when the lift is moving downwards.

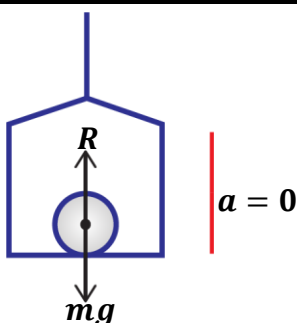
c) If the lift is stationary or moving with uniform velocity:

Resultant force, $F = ma$

Considering upward motion of the lift.

$$R - mg = ma$$

$$R = mg + m \times 0$$

$$R = mg$$

The Reaction (Apparent weight of the body), \mathbf{R} is equal to the actual weight of the body.

NOTE:

If the cable or rope of the lift breaks, the lift will fall freely under the influence of gravity. Therefore, the acceleration of the lift is equal to the acceleration due to gravity, g .

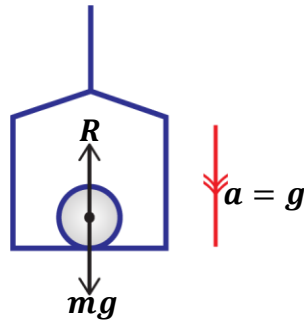

$$\text{Resultant force, } F = ma$$

$$mg - R = ma$$

$$R = mg - ma$$

$$R = mg - mg$$

$$R = 0$$

The Reaction (Apparent weight of the body), R is 0N.

➤ This explains why a person standing in a lift feels weightless when the lift is falling freely.

Examples:

1. A girl of mass 50kg stands in a stationary lift on earth. Calculate her apparent weight when the lift

- accelerates upwards at 2ms^{-2} .
- accelerates downwards at 2ms^{-2} .
- falls freely under gravity.

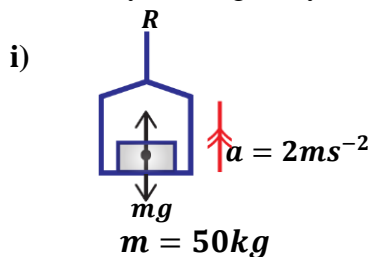

$$\text{Resultant force, } F = ma$$

$$R - mg = ma$$

$$R = mg + ma$$

$$R = 50 \times 10 + 50 \times 2$$

$$R = 600\text{N}$$

$$\text{Apparent weight} = 600\text{N}$$

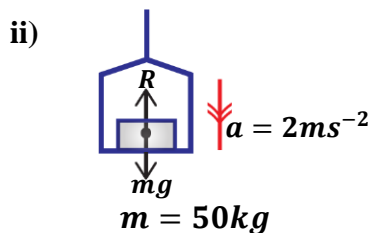

$$\text{Resultant force, } F = ma$$

$$mg - R = ma$$

$$R = mg - ma$$

$$R = 50 \times 10 - 50 \times 2$$

$$R = 400\text{N}$$

$$\text{Apparent weight} = 400\text{N}$$

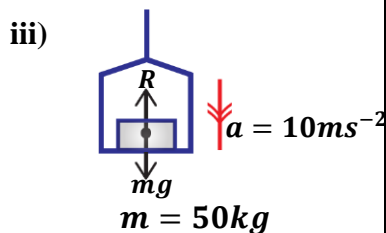

$$\text{Resultant force, } F = ma$$

$$mg - R = ma$$

$$R = mg - ma$$

$$R = 50 \times 10 - 50 \times 10$$

$$R = 0\text{N}$$

$$\text{Apparent weight} = 0\text{N}$$

2. A person of mass 78kg is standing inside an electric lift. What is the apparent weight of the person if the;

- lift is moving upwards with an acceleration of 4ms^{-2} .
- lift is descending with an acceleration of 4ms^{-2}

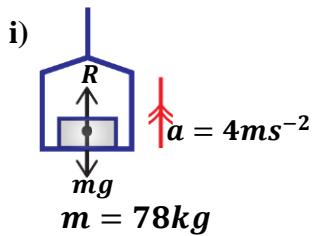

$$\text{Resultant force, } F = ma$$

$$R - mg = ma$$

$$R = mg + ma$$

$$R = 78 \times 10 + 78 \times 4$$

$$R = 1092\text{N}$$

$$\text{Apparent weight} = 1092\text{N}$$

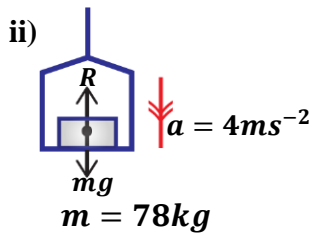

$$\text{Resultant force, } F = ma$$

$$mg - R = ma$$

$$R = mg - ma$$

$$R = 78 \times 10 - 78 \times 4$$

$$R = 468\text{N}$$

$$\text{Apparent weight} = 468\text{N}$$

3. A block of mass 40kg is pulled from rest along a horizontal surface by a rope connected to one face of the block as shown below.



Given that the tension in the rope is 200N and that the frictional force between the block and the horizontal surface is 140N , find;

- the acceleration of the block.
- The distance moved in 5s .

i)

$$T = 200\text{N}, \quad F_R = 140\text{N}$$

$$\text{Resultant force, } F = ma$$

$$T - F_R = ma$$

$$200 - 140 = 40a$$

$$a = \frac{60}{40}$$

$$a = 1.5\text{ms}^{-2}$$

$$u = 0\text{ms}^{-1}, \quad t = 5\text{s}$$

$$\text{From, } s = ut + \frac{1}{2}at^2$$

$$s = 0 \times 5 + \frac{1}{2} \times 1.5 \times 5^2$$

$$s = \frac{37.5}{2}$$

$$s = 18.75\text{m}$$

Other applications of Newton's third law include:

- **Recoiling of a gun when a bullet is fired:**

When a bullet is fired from a gun, the gun exerts a force on the bullet in the forward direction. This is the action force. The bullet also exerts an equal force on the gun in the backward direction. This is the reaction force. Due to the large mass of the gun, it moves a small distance backward giving a jerk at the shoulder of the gunman. This backward movement of the gun is called recoil of the gun.

- **Rowing of a boat.**

During rowing of a boat, the boatman pushes the water backwards with the oars (action force). The water also apply an equal and opposite push on the boat which moves the boat forward (reaction)

- **Rocket propulsion:**

During propulsion of a rockets, fuels are burnt, and the engine produces hot exhaust gases which flow out from the back of the engine (action). In reaction, a thrusting force is produced in an opposite direction.

EXERCISE:

1. A car of mass 5000kg initially moving at a velocity of 50m/s accelerates to 100m/s in 2 seconds. Calculate the engine force on the car that caused the velocity change.
2. A lift moves up and then down with an acceleration of 3ms^{-2} . Calculate the reaction by the floor on the passenger of mass 60kg standing in the lift in each case.
3. A block of mass 8kg rests on a rough horizontal surface. It is being pulled from rest by a rope connected to one end of the block. Given that the tension in the rope is 20N and the friction force between the surface and the block is 4N , calculate;
 - i) Acceleration of the system.
 - ii) Distance moved by the block in 10s .
4. A girl of mass 500g stands in a stationary lift on earth. Calculate her apparent weight when the lift
 - i) accelerates upwards at 2ms^{-2} .
 - ii) accelerates upwards at 2ms^{-2} .
 - iii) falls freely under gravity.
5. A spring balance carrying a mass of 4.0kg on its hook is hanged from the ceiling of a lift. Determine the spring balance reading when the lift is
 - i) ascending with an acceleration of 4ms^{-2} .
 - ii) descending with an acceleration of 4ms^{-2} .
 - iii) ascending with a uniform velocity of 4ms^{-2} .
6. A block of mass 10kg accelerates uniformly at a rate 3ms^{-2} along a horizontal table when a force of 40N acts on it. Find the frictional force between the block and the table.
7. A trolley of mass 2kg is pulled from rest by a horizontal force of 5N for 1.2 seconds. If there is no frictional force between the horizontal surface and the wheels of the trolley, calculate the
 - i) acceleration and velocity of the trolley after 1.2 seconds.
 - ii) distance covered by the trolley.
 - iii) kinetic energy gained by the trolley.
8. A man with a mass of 85kg steps onto a weighing balance placed on the floor of the lift (Elevator).
 - a) What would be the initial reading of the weighing balance?
 - b) If the elevator accelerates up at 2.5ms^{-2} , what is the new weighing balance reading?
 - c) If the elevator accelerates downwards at 2.5ms^{-2} , what is the new weighing balance reading?

LINEAR MOMENTUM

In the game of football, a player with a more momentum is hard to stop. The player has the ability to continue moving because of his mass and velocity. Therefore, any moving body possess momentum.

Definition:

Momentum is the product of mass of a body and its velocity.

$$\text{Momentum} = \text{mass} \times \text{velocity}$$

$$p = m \times v$$

$$\boxed{p = mv}$$

The SI unit of momentum is kilogram metre per second (kgms^{-1}).

❖ Momentum is a vector quantity and its direction is the same as that of the velocity.

Factors affecting momentum of a body:

Mass of a body:

The momentum of a body increases with increase in its mass.

This explains why;

- A heavy hammer can drive a nail deeper into a piece of wood than a lighter hammer.
- A heavy footballer is harder to stop once in motion than a small footballer.

Velocity of a body:

The momentum of a body increases with increase in its velocity.

This explains why;

- A fast-moving ball is not easier to stop than a slow-moving ball.
- A fast-moving car causes more damage when it makes an accident than a slow-moving car.

Examples:

1. Find the momentum of a car of mass 600kg moving with a constant velocity of 30ms^{-1} .

$$m = 600\text{kg}, \quad v = 30\text{ms}^{-1}$$

$$\text{Momentum} = \text{mass} \times \text{velocity}$$

$$p = mv$$

$$p = 600 \times 30$$

$$p = 18000\text{kgms}^{-1}$$

2. An object has a mass of 200kg and a momentum of 3800kgms^{-1} . At what velocity is it moving?

$$m = 200\text{kg}, \quad p = 3800\text{kgms}^{-1}$$

$$\text{Momentum} = \text{mass} \times \text{velocity}$$

$$p = mv$$

$$3800 = 200 \times v$$

$$v = \frac{3800}{200}$$

$$v = 19\text{ms}^{-1}$$

3. A truck of mass 1200kg initially moving with a velocity of 15ms^{-1} accelerated uniformly at a rate of 1.5ms^{-2} for 10s . Find;
 - i) its initial momentum.
 - ii) its final velocity after 10s .
 - iii) its final momentum.
 - iv) the difference in momentum.

$$m = 1200\text{kg}, \quad u = 15\text{ms}^{-1}, \quad t = 10\text{s}$$

$$a = 1.5\text{ms}^{-2}$$

i) initial momentum

$$p_1 = mu$$

$$p_1 = 1200 \times 15$$

$$p_1 = 18000\text{kgms}^{-1}$$

ii) final velocity

$$v = u + at$$

$$v = 15 + 1.5 \times 10$$

$$v = 30\text{ms}^{-1}$$

iii) final momentum

$$p_2 = mv$$

$$p_2 = 1200 \times 30$$

$$p_2 = 36000\text{kgms}^{-1}$$

iv) change in momentum

$$p_2 - p_1 = 36000 - 18000$$

$$p_2 - p_1 = 18000\text{kgms}^{-1}$$

4. Calculate the kinetic energy possessed by a body of mass 10kg moving with a momentum of 200kgms^{-1} .

$$m = 10\text{kg}, \quad p = 200\text{kgms}^{-1}$$

$$p = mv$$

$$200 = 10 \times v$$

$$v = \frac{200}{10}$$

$$v = 20\text{ms}^{-1}$$

$$K.E = \frac{1}{2}mv^2$$

$$K.E = \frac{1}{2} \times 10 \times 20^2$$

$$K.E = 2000\text{J}$$

Principle of conservation of linear momentum:

It states that when two or more bodies collide, their total linear momentum remains constant provided no external force is acting.

i.e. **Total momentum before collision = Total momentum after collision**

COLLISIONS:

When bodies come into contact with each other, they are said to have collided. Therefore, they experience a force from each other which changes their momentum.

However, if there are no external forces participating in the collision, the total momentum after collision remains the same as before collision.

Types of collisions:

There are two types of collisions namely;

- Elastic collision.
- Inelastic collision.

ELASTIC COLLISION:

This is the type of collision where the colliding bodies separate after collision and move with different velocities.

During elastic collision;

- Momentum is conserved i.e. total momentum before collision is equal to total momentum after collision.
- Kinetic energy is also conserved i.e. total kinetic energy before collision is equal to total kinetic energy after collision.

Consider two bodies of masses m_1 and m_2 moving with initial velocities, u_1 and u_2 respectively. After their collision, they move with final velocities, v_1 and v_2 respectively.



From the principle of linear conservation of momentum;

Total momentum before collision = Total momentum after collision

$$m_1u_1 + m_2u_2 = m_1v_1 + m_2v_2$$

For kinetic energy;

Total kinetic energy before collision = Total kinetic energy after collision

$$\frac{1}{2}m_1u_1^2 + \frac{1}{2}m_2u_2^2 = \frac{1}{2}m_1v_1^2 + \frac{1}{2}m_2v_2^2$$

INELASTIC COLLISION:

This is the type of collision where the colliding bodies stay together after collision and move with the same velocity.

During inelastic collision;

- Momentum is conserved i.e. total momentum before collision is equal to total momentum after collision.
- Kinetic energy is not conserved i.e. total kinetic energy before collision is not equal to total kinetic energy after collision.

Consider two bodies of masses m_1 and m_2 moving with initial velocities, u_1 and u_2 respectively. After their collision, they move with the same final velocity, v .

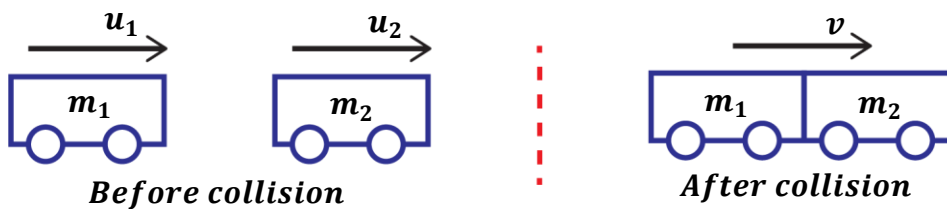

From the principle of linear conservation of momentum;

Total momentum before collision = Total momentum after collision

$$m_1u_1 + m_2u_2 = m_1v + m_2v$$

$$m_1u_1 + m_2u_2 = (m_1 + m_2)v$$

For kinetic energy;

Total kinetic energy before collision \neq Total kinetic energy after collision

$$\frac{1}{2}m_1u_1^2 + \frac{1}{2}m_2u_2^2 \neq \frac{1}{2}m_1v^2 + \frac{1}{2}m_2v^2$$

$$\frac{1}{2}m_1u_1^2 + \frac{1}{2}m_2u_2^2 \neq \frac{1}{2}(m_1 + m_2)v^2$$

Causes of kinetic energy losses in inelastic collision include;

- Some kinetic energy is converted into heat energy leading to increase in temperature of the colliding bodies.
- Some kinetic energy is converted in sound energy as the bodies collide.

DIFFERENCES BETWEEN ELASTIC AND INELASTIC COLLISION

Elastic collision	Inelastic collision
<ul style="list-style-type: none"> ▪ Bodies separate after collision. ▪ Both momentum and kinetic energy are conserved. ▪ Bodies move with different velocities after collision. 	<ul style="list-style-type: none"> ▪ Bodies stick together after collision. ▪ Kinetic energy is not conserved but momentum is conserved. ▪ Bodies move with the same velocity after collision.

Examples:

Note: The bodies should have the same units of mass and velocity.

1. Ball A of mass $400g$ moving with a velocity of $20ms^{-1}$ collided with ball B of mass $50g$ at rest. If ball B moves with a velocity of $10ms^{-1}$ after collision in the direction of ball A.

Find

- the velocity of ball A after collision.
- kinetic energy after collision.

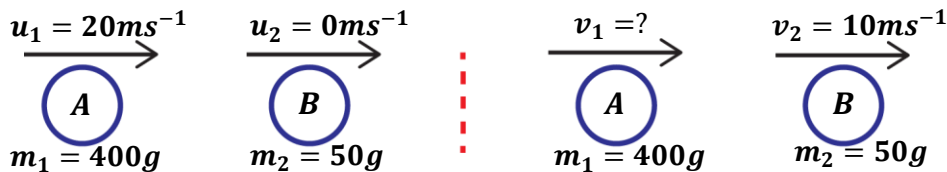

- Total momentum before collision = Total momentum after collision**

$$\begin{aligned}
 m_1u_1 + m_2u_2 &= m_1v_1 + m_2v_2 \\
 400 \times 20 + 50 \times 0 &= 400 \times v_1 + 50 \times 10 \\
 8000 &= 400v_1 + 500 \\
 7500 &= 400v_1 \\
 v_1 &= \frac{7500}{400} \\
 v_1 &= 18.75ms^{-1}
 \end{aligned}$$

- Kinetic energy after collision**

$$\begin{aligned}
 K.E &= \frac{1}{2}m_1v_1^2 + \frac{1}{2}m_2v_2^2 \\
 K.E &= \frac{1}{2} \times \left(\frac{400}{1000}\right) \times 18.75^2 + \frac{1}{2} \times \left(\frac{50}{1000}\right) \times 10^2 \\
 K.E &= \frac{140.625}{2} + \frac{5}{2} \\
 K.E &= 70.3125 + 2.5 \\
 K.E &= 72.8125J
 \end{aligned}$$

2. A trolley P of mass $150g$ moving with a velocity of $20ms^{-1}$ collides with another stationary trolley Q of mass $100g$. If the two trolleys move together after collision, calculate their common velocity.

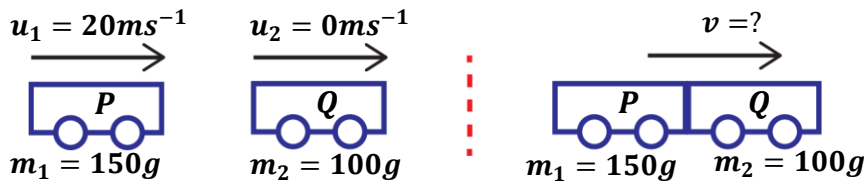

Total momentum before collision = Total momentum after collision

$$\begin{aligned}
 m_1u_1 + m_2u_2 &= (m_1 + m_2)v \\
 150 \times 20 + 100 \times 0 &= (150 + 100)v \\
 3000 &= 250v \\
 v &= \frac{3000}{250} \\
 v &= 12ms^{-1}
 \end{aligned}$$

3. A body of mass $3kg$ travelling at $5ms^{-1}$ collides with a $2kg$ body moving at $8ms^{-1}$ in the same direction. If after collision the two bodies moved together, calculate the velocity with which the two bodies move after collision.

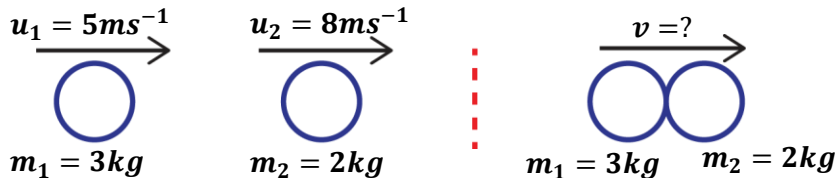

Total momentum before collision = Total momentum after collision

$$\begin{aligned}
 m_1u_1 + m_2u_2 &= (m_1 + m_2)v \\
 3 \times 5 + 2 \times 8 &= (3 + 2)v \\
 31 &= 5v \\
 v &= \frac{31}{5} \\
 v &= 6.2ms^{-1}
 \end{aligned}$$

4. A body of mass $4kg$ moving with a velocity of $25ms^{-1}$ collided with another body of mass $5kg$ moving with a velocity of $40ms^{-1}$ from the opposite direction. If the $4kg$ mass moves with a velocity of $10ms^{-1}$ after collision, find the velocity of the $5kg$ mass after collision.

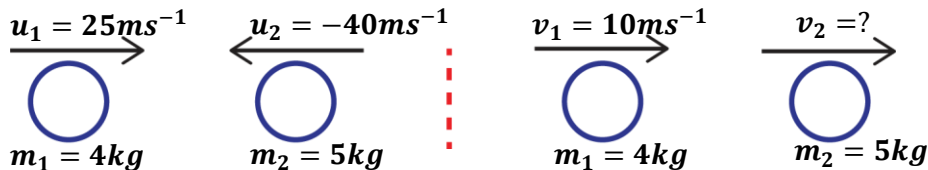

Total momentum before collision = Total momentum after collision

$$\begin{aligned}
 m_1u_1 + m_2u_2 &= m_1v_1 + m_2v_2 \\
 4 \times 25 + 5 \times -40 &= 4 \times 10 + 5 \times v_2 \\
 -100 &= 40 + 5v_2 \\
 -140 &= 5v_2 \\
 v_2 &= \frac{-140}{5} \\
 v_2 &= -28ms^{-1}
 \end{aligned}$$

The negative sign shows
a change in direction

5. An object of mass 2kg moving at 5ms^{-1} collides with another of mass 3kg which is at rest. Find
- velocity of the two bodies if they stick together after collision.
 - loss in kinetic energy.

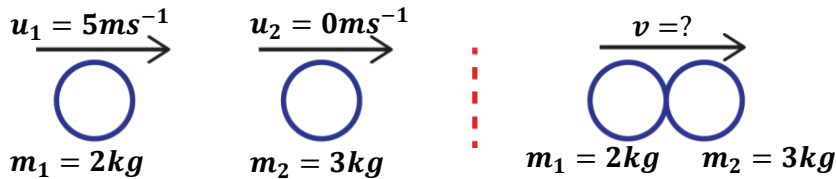

a) **Total momentum before collision = Total momentum after collision**

$$\begin{aligned}
 m_1 u_1 + m_2 u_2 &= (m_1 + m_2)v \\
 2 \times 5 + 3 \times 0 &= (2 + 3)v \\
 10 &= 5v \\
 v &= \frac{10}{5} \\
 v &= 2\text{ms}^{-1}
 \end{aligned}$$

b) **Loss in kinetic energy**

Loss = kinetic energy before collision – kinetic energy after collision

$$\begin{aligned}
 \text{Loss} &= \left[\frac{1}{2} m_1 u_1^2 + \frac{1}{2} m_2 u_2^2 \right] - \left[\frac{1}{2} (m_1 + m_2) v^2 \right] \\
 \text{Loss} &= \left[\frac{1}{2} \times 2 \times 5^2 + \frac{1}{2} \times 3 \times 0^2 \right] - \left[\frac{1}{2} \times (2 + 3) \times 2^2 \right] \\
 \text{Loss} &= \left[\frac{25}{2} \right] - \left[\frac{20}{2} \right] \\
 \text{Loss} &= 12.5 - 10 \\
 \text{Loss} &= 2.5 \text{ J}
 \end{aligned}$$

6. A particle P of mass 1kg moving with a velocity of 2ms^{-1} is knocked directly from behind by another particle Q moving at 4ms^{-1} . If the velocity of P increases to 4.5ms^{-1} and velocity of Q reduces to 2.75ms^{-1} , find the mass of particle Q.

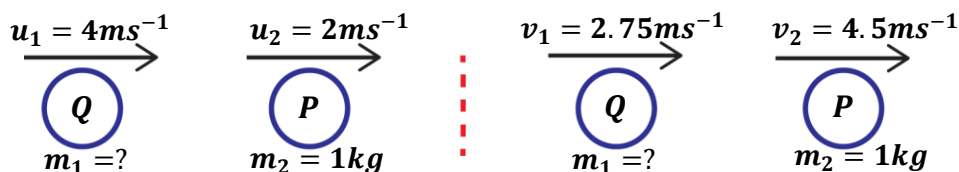

Total momentum before collision = Total momentum after collision

$$\begin{aligned}
 m_1 u_1 + m_2 u_2 &= m_1 v_1 + m_2 v_2 \\
 m_1 \times 4 + 1 \times 2 &= m_1 \times 2.75 + 1 \times 4.5 \\
 4m_1 + 2 &= 2.75m_1 + 4.5 \\
 4m_1 - 2.75m_1 &= 4.5 - 2 \\
 1.25m_1 &= 2.5 \\
 m_1 &= \frac{2.5}{1.25} \\
 m_1 &= 2\text{kg}
 \end{aligned}$$

7. An arrow of mass $100g$ moving at a velocity of $16ms^{-1}$ horizontally enters a block of wood of mass $540g$ lying at rest on a smooth surface.
- State the type of collision.
 - Find the common velocity after the impact.
 - Calculate the loss in kinetic energy.

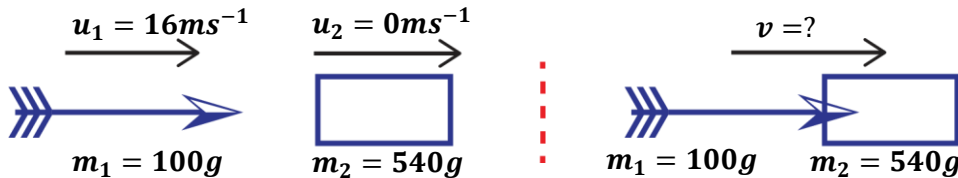

- Inelastic collision**
- Total momentum before collision = Total momentum after collision**

$$\begin{aligned}
 m_1 u_1 + m_2 u_2 &= (m_1 + m_2)v \\
 100 \times 16 + 540 \times 0 &= (100 + 540)v \\
 1600 &= 640v \\
 v &= \frac{1600}{640} \\
 v &= 2.5ms^{-1}
 \end{aligned}$$

- Loss in kinetic energy**

$$\begin{aligned}
 m_1 = 100g &= \frac{100}{1000} = 0.1kg, \quad m_2 = 540g = \frac{540}{1000} = 0.54kg \\
 \text{Loss} &= \text{kinetic energy before collision} - \text{kinetic energy after collision} \\
 \text{Loss} &= \left[\frac{1}{2} m_1 u_1^2 + \frac{1}{2} m_2 u_2^2 \right] - \left[\frac{1}{2} (m_1 + m_2) v^2 \right] \\
 \text{Loss} &= \left[\frac{1}{2} \times 0.1 \times 16^2 + \frac{1}{2} \times 0.54 \times 0^2 \right] - \left[\frac{1}{2} \times (0.1 + 0.54) \times 2.5^2 \right] \\
 \text{Loss} &= \left[\frac{25.6}{2} \right] - \left[\frac{4}{2} \right] \\
 \text{Loss} &= 12.8 - 2 \\
 \text{Loss} &= 10.8 J
 \end{aligned}$$

8. The figure below shows a system where vehicle A of mass $1500kg$ travelling at a velocity of $72km/hr$ towards a stationary vehicle B of mass $900kg$.



If A collides with B, the two move together at a constant velocity for 20 seconds, calculate;

- the common velocity.
- the distance moved after the impact.

$$\begin{aligned}
 u_2 = 72km/hr &= \frac{72 \times 1000}{3600} = 20ms^{-1} \\
 u_1 &= 0ms^{-1}
 \end{aligned}$$

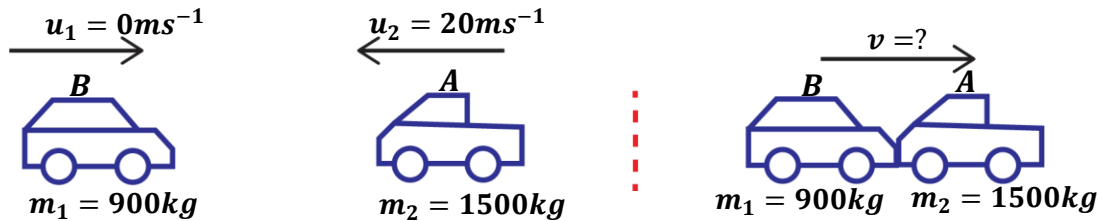

i) **Total momentum before collision = Total momentum after collision**

$$\begin{aligned}
 m_1u_1 + m_2u_2 &= (m_1 + m_2)v \\
 900 \times 0 + 1500 \times 20 &= (900 + 1500)v \\
 30000 &= 2400v \\
 v &= \frac{30000}{2400} \\
 v &= 12.5\text{ms}^{-1}
 \end{aligned}$$

ii) $t = 20\text{s}$, $u = 12.5\text{ms}^{-1}$, $a = 0\text{ms}^{-2}$ since velocity is constant

$$\begin{aligned}
 \text{From, } s &= ut + \frac{1}{2}at^2 \\
 s &= 12.5 \times 20 + \frac{1}{2} \times 0 \times 20^2 \\
 s &= 250\text{m}
 \end{aligned}$$

9. A moving ball P of mass 100g collides with a stationary ball Q of mass 200g. After collision, P moves backwards with a velocity of 2ms^{-1} while Q moves forward with a velocity of 5ms^{-1} . Calculate;

i) the initial velocity of P.

ii) the force exerted by P on Q if the collision took 5s.

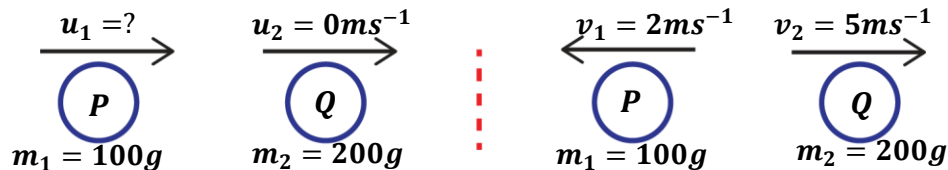

i) **Total momentum before collision = Total momentum after collision**

$$\begin{aligned}
 m_1u_1 + m_2u_2 &= m_1v_1 + m_2v_2 \\
 100 \times u_1 + 200 \times 0 &= 100 \times 2 + 200 \times 5 \\
 100u_1 &= 1200 \\
 u_1 &= \frac{1200}{100} \\
 u_1 &= 12\text{ms}^{-1}
 \end{aligned}$$

ii) **Force exerted by P on Q**

$$\text{For P, } u_1 = 12\text{ms}^{-1}, \quad v_1 = 2\text{ms}^{-1}, \quad t = 5\text{s}, \quad m_1 = 100\text{g} = \frac{100}{1000} = 0.1\text{kg}$$

$$a = \frac{v_1 - u_1}{t} = \frac{2 - 12}{5} = -2\text{ms}^{-2} = 2\text{ms}^{-2}(\text{deceleration})$$

$$F = ma$$

$$F = 0.1 \times 2$$

$$F = 0.2\text{N}$$

IMPULSE

When a force is applied on a free object for some amount of time, it changes its velocity thus changing the momentum of the body. This impact created by the force is referred to as **impulse**.

Definition:

Impulse is the product of force and its time of action on the body.

$$\text{Impulse} = \text{Force} \times \text{Time}$$

$$\boxed{I = Ft}$$

The SI unit of impulse is Newton second (Ns).

From Newton's second law of motion, $F = ma$

$$I = Ft$$

$$I = mat$$

$$I = m \frac{(v - u)}{t} \times t$$

$$I = m(v - u)$$

$$\boxed{I = mv - mu}$$

Therefore, Impulse can be defined as the change in momentum of the body.

The other unit of Impulse is kgms^{-1} .

Examples:

1. A body of mass 2kg changes its velocity from 10ms^{-1} to 45ms^{-1} after a period of time. Calculate the impulse on the body.

$$m = 2\text{kg}, \quad u = 10\text{ms}^{-1}, \quad v = 45\text{ms}^{-1}$$

$$I = mv - mu$$

$$I = (2 \times 45) - (2 \times 10)$$

$$I = 90 - 20$$

$$I = 70\text{kgms}^{-1}$$

2. A body of mass 4.5kg accelerates uniformly at 2ms^{-2} for 5 seconds. Calculate the impulse on the body.

$$m = 4.5\text{kg}, \quad a = 2\text{ms}^{-2}, \quad t = 5\text{s}$$

$$F = ma$$

$$F = 4.5 \times 2$$

$$F = 9\text{N}$$

$$I = Ft$$

$$I = 9 \times 5$$

$$I = 45\text{Ns}$$

3. An object is acted upon by a force of 50N for 2 minutes. Calculate the impulse on the object.

$$F = 50\text{N}, \quad t = 2 \text{ mins} = 2 \times 60 = 120\text{s}$$

$$I = Ft$$

$$I = 50 \times 120$$

$$I = 6000\text{Ns}$$

4. A footballer kicks a ball of mass 0.25kg initially at rest with a force of 200N that acts on the ball for 0.5s . Find;

- the impulse of the force on the ball.
- the takeoff velocity of the ball

a) $F = 200N$, $t = 0.5s$, $m = 0.25kg$

$$I = Ft$$

$$I = 200 \times 0.5$$

$$I = 100Ns$$

b) $u = 0ms^{-1}$, $v = ?$

$$I = mv - mu$$

$$100 = 0.25 \times v - 0.25 \times 0$$

$$0.25v = 100$$

$$v = \frac{100}{0.25}$$

$$v = 400ms^{-1}$$

EFFECTS OF IMPULSIVE FORCES ON THE BODY

Though impulsive forces act for a short period of time, they are sometimes disadvantageous to a body on which they act. Some of the negative effects include;

- Impulsive forces tend to change the shape of colliding bodies.
- Impulsive forces tend harm bodies e.g. pain after knocking a stone.

In order to reduce the above negative effects, the time of action of the force on the body is increased or prolonged.

This explains the following applications:

- ❖ A goal keeper draws his hands towards his body when catching a fast-moving ball. This increases the time of action of the force on the ball thus reducing the pain that would be felt by the goal keeper after catching the ball.
- ❖ Goal keepers wear soft gloves that absorb shocks on their hands. The soft gloves reduce the force on the hands by increasing the time of action of the force.
- ❖ The nets at the back of a goal post are made loose to increase the time of action of the impact as the ball hits the net. This prevents the net from getting torn.
- ❖ Shock absorbers are put in vehicles to reduce the force exerted on the vehicles as they move over pot holes. The shock absorbers increase the time of action of the impact of force.
- ❖ High jumpers usually bend their knees on landing. This increases the time of impact hence reducing injuries on the jumpers.
- ❖ High jumpers land in sand or soft cushions that increase the time of action of the impact thus absorbing the shocks on the jumper.
- ❖ In golf, players follow the ball as it is hit. This reduces the reaction force the player feels on hitting the ball by increasing the time of contact.
- ❖ Cars are fitted with air bag. During an accident, air bags increase the time of action of the impact thus a less force is exerted on a person over a long period of time. This reduces injuries.
- ❖ Objects that easily break like eggs are packed in soft, shock-absorbing boxes. This reduces the possibility of them cracking on sudden stop or start of motion. The shock-absorbing boxes increase the time of impact on the eggs.

APPLICATIONS OF THE PRINCIPLE OF CONSERVATION OF MOMENTUM

The principle of conservation of linear momentum is applied in:

Rockets:

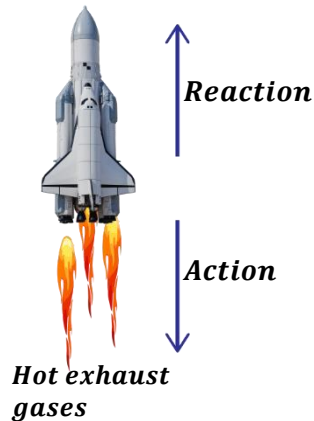

During propulsion of a rockets, fuels are burnt in the rocket engine, and the engine produces hot exhaust gases which escape through the engine nozzle with a large velocity hence a large momentum. In turn, the escaping gases produce a force which impart an equal but opposite momentum to the rocket. This momentum propels the rocket to move forward with a very high velocity.

Jet planes:



During movement of jet planes, fuels are burnt in the jet engines, and the engine produces hot exhaust gases which escape through the exhaust pipes with a large velocity hence a large momentum. In turn, the escaping gases produce a force which impart an equal but opposite momentum to the jet plane. This momentum forces the jet plane to move forward with a very high velocity.

Explosion of a bomb:

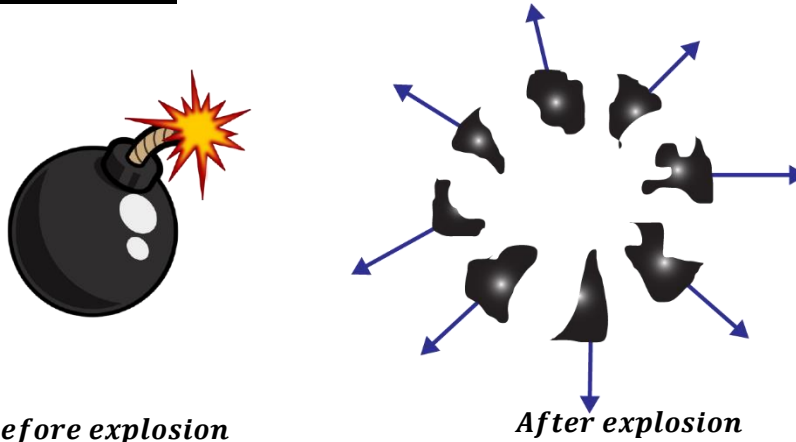

Before explosion

After explosion

Before a bomb explodes, its total momentum is zero since it is at rest. When it explodes, the bomb breaks into very many fragments (parts) with each fragment having a particular momentum. A fragment moving in one direction with a particular momentum has another fragment with the same momentum moving in an opposite direction. Therefore, the total momentum of the fragments is also zero thus momentum before explosion is equal to momentum after collision.

Recoil of a gun:

Before firing a bullet from a gun, the gun and the bullet are at rest. After firing, the gun exerts a force on the bullet in the forward direction (action) but also the bullet exerts an equal force on the gun in the backward direction (reaction) thus the gun moves backward i.e. recoiling.

Therefore, the bullet receives an equal but opposite momentum to that of the gun.

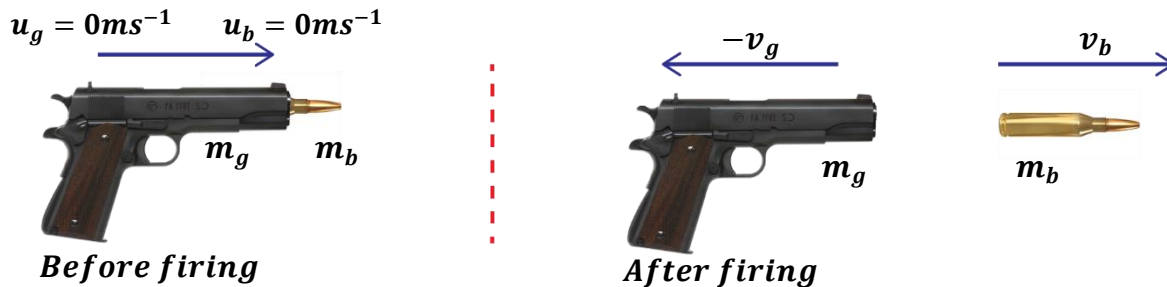

From the principle of linear conservation of momentum;

Total momentum before firing = Total momentum after firing

$$\begin{aligned}
 m_g u_g + m_b u_b &= m_g v_g + m_b v_b \\
 m_g \times 0 + m_b \times 0 &= m_g \times -v_g + m_b v_b \\
 0 &= -m_g v_g + m_b v_b \\
 \boxed{m_g v_g} &= \boxed{m_b v_b}
 \end{aligned}$$

NOTE:

- The velocity of the gun, v_g is called the **Recoil velocity**.
- The velocity of the bullet, v_b is called the **muzzle velocity**.

Examples:

1. A bullet of mass 8g is fired from a gun of mass 500g. If the muzzle velocity of the bullet is $500ms^{-1}$, calculate the recoil velocity of the gun.

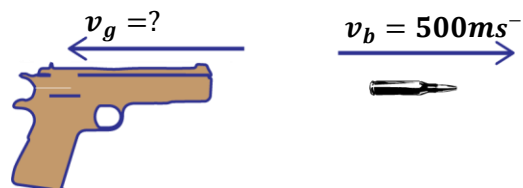
$$\begin{aligned}
 m_g = 500g &= \frac{500}{1000} = 0.5kg & m_b = 8g &= \frac{8}{1000} = 0.008kg \\
 v_g = ? & & v_b = 500ms^{-1} &
 \end{aligned}$$

momentum of the gun = momentum of the bullet

$$\begin{aligned}
 m_g v_g &= m_b v_b \\
 0.5 \times v_g &= 0.008 \times 500 \\
 0.5 v_g &= 4 \\
 v_g &= \frac{4}{0.5} \\
 v_g &= 8ms^{-1}
 \end{aligned}$$

2. A bullet of mass 20g is fired from a gun of mass 0.4kg, if the gun recoils with the velocity of $40ms^{-1}$, calculate the velocity of the bullet.

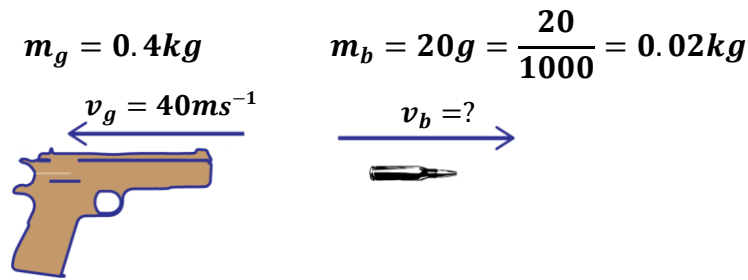

momentum of the gun = momentum of the bullet

$$\begin{aligned}
 m_g v_g &= m_b v_b \\
 0.4 \times 40 &= 0.02 \times v_b \\
 16 &= 0.02 v_b \\
 v_b &= \frac{16}{0.02} \\
 v_b &= 800ms^{-1}
 \end{aligned}$$

3. A bullet of mass 20g is fired from the gun of mass 0.4kg. If the velocity of the bullet is $400ms^{-1}$, calculate;
- the recoil velocity of the gun.
 - the kinetic energy gained by the gun.

$m_g = 0.4kg$	$m_b = 20g = \frac{20}{1000} = 0.02kg$	$v_b = 400ms^{-1}$	$v_g = ?$
i)		ii)	
momentum of the gun = momentum of the bullet		$K.E = \frac{1}{2} m_g v_g^2$	
$m_g v_g = m_b v_b$		$K.E = \frac{1}{2} \times 0.4 \times 20^2$	
$0.4 \times v_g = 0.02 \times 400$		$K.E = \frac{160}{2}$	
$0.4 v_g = 8$		$K.E = 80 J$	
$v_g = \frac{8}{0.4}$			
$v_g = 20ms^{-1}$			

4. A bullet of mass 6g is fired from a gun of mass 500g. If the muzzle velocity of the bullet is $300ms^{-1}$, calculate the recoil velocity of the gun.

$$m_g = 500g = \frac{500}{1000} = 0.5kg \quad m_b = 6g = \frac{6}{1000} = 0.006kg \quad v_b = 300ms^{-1} \quad v_g = ?$$

momentum of the gun = momentum of the bullet

$$\begin{aligned}
 m_g v_g &= m_b v_b \\
 0.5 \times v_g &= 0.006 \times 300 \\
 0.5 v_g &= 1.8 \\
 v_g &= \frac{1.8}{0.5} \\
 v_g &= 3.6ms^{-1}
 \end{aligned}$$

5. A bullet of mass $12g$ travelling at $150ms^{-1}$ penetrates deeply into a fixed soft wood and is brought to rest in $0.015s$. calculate how deep the bullet penetrates the wood.

$$m_b = 12g = \frac{12}{1000} = 0.012kg$$

$$u_b = 150ms^{-1}, \quad v_b = 0ms^{-1}, \quad t = 0.015s$$

$$a = \frac{v_b - u_b}{t}$$

$$a = \frac{0 - 150}{0.015}$$

$$a = -10000ms^{-2}$$

$$\text{From } s = ut + \frac{1}{2}at^2$$

$$s = 150 \times 0.015 + \frac{1}{2} \times -10000 \times 0.015^2$$

$$s = 2.25 - 1.125$$

$$s = 1.125m$$

EXERCISE:

- A bus of mass $7500kg$ travelling at $30ms^{-1}$ collides inelastically with a van which is approaching from the opposite side at $32ms^{-1}$. If the van has a mass of $2500kg$, at what velocity do the van and bus travel with after collision?
- Car A of mass $2000kg$ travelling at $0.5ms^{-1}$ collides with another car B of half the mass of A moving in opposite direction with a velocity of $0.4ms^{-1}$. If the trucks stay together on collision, calculate the common velocity with which they move.
- A bullet of mass $1.5 \times 10^{-2}kg$ is fired from a riffle of mass $3kg$ with a muzzle velocity of $180kmh^{-1}$. Calculate the recoil velocity of the riffle.
- A trolley P of mass $150g$ moving with a velocity of $20ms^{-1}$ collides with another stationary trolley X of mass $100g$. If P and X move together after collision, calculate;
 - momentum of P before collision.
 - the velocity of P and X with which they moved after collision.
- A gun of mass $5kg$ fires a bullet of mass $50g$ at a speed of $500ms^{-1}$. Calculate the recoil velocity of the gun.
- A car of mass $1500kg$ moving with a velocity of $25ms^{-1}$ collides directly with another car of mass $1400kg$ at rest so that the two stick and move together. Find their common velocity.
- A bullet of mass $30g$ is fired into a stationary block of wood of mass $480g$ lying on a smooth horizontal surface. If the bullet gets embedded in the block and the two move together at a speed of $15ms^{-1}$. Find;
 - the speed of the bullet before it hits the block.
 - The kinetic energy lost.
- A moving ball A of mass $200g$ collides directly with a stationary ball B of mass $300g$ so that A bounces with a velocity of $2ms^{-1}$ while B moves forward with a velocity of $3ms^{-1}$. Calculate the initial velocity of A.
- A particle X of mass $2kg$ originally moving with a velocity of $3ms^{-1}$ collides directly with another particle Y of mass $2kg$ which is moving at a velocity of $2ms^{-1}$ in the opposite direction so that the velocity of X becomes $1ms^{-1}$ after the impact. Find the velocity of Y after the impact.
- A bullet of mass $40g$ is fired with a velocity of $200ms^{-1}$ from a gun of mass $5kg$. What is the recoil velocity of the gun?

11. A one-tonne car travelling at 20ms^{-1} is accelerated at 2ms^{-2} for 5 seconds. Calculate the;
 - i) change in momentum.
 - ii) rate of change of momentum.
 - iii) accelerating force acting on the body.
12. A man of mass 6kg jumps from a high wall and lands on a hard floor at a velocity of 6ms^{-1} . Calculate the force exerted on the man's legs if;
 - a) he bends his knees on landing so that it takes 1.2s for his motion to be stopped.
 - b) he does not bend his knees and it takes 0.06s to stop his motion.
13.
 - a) Explain why a passenger standing on the floor of a lorry jerks backwards when the lorry starts moving forwards.
 - b) A 7-tonne truck initially moving at a velocity of 50ms^{-1} accelerates to 80ms^{-1} in 3 seconds. Calculate the force on the truck that caused the velocity change.
14. A van of mass 1.5 tonnes travelling at 20ms^{-1} hits a wall and is brought to rest as a result in 0.5 seconds. Calculate the;
 - i) impulse.
 - ii) average force exerted on the wall.
15. A goal keeper is to catch a ball of mass 0.25kg travelling at 250ms^{-1} . Find the impulsive force exerted on the goal keeper's hands
 - i) if the impact lasts for 0.2s .
 - ii) if the impact lasts for 1s when the goal keeper draws his hands towards his body as he catches the ball.
16. A car of mass 2000kg travelling at 5m/s collides with a mini-bus of mass 5000kg travelling in the opposite direction at 7m/s . The vehicles stick and move together after collision. If the collision lasts 0.1 seconds.
 - a) Determine the velocity of the system after collision to 3 decimal places.
 - b) Calculate the impulsive force on the mini-bus.
17. Explain the following observations:
 - i) a water jet directed to a spot on the ground digs a hole in the ground after sometime.
 - ii) A goal keeper draws hands to his body when catching a fast-moving ball.
 - iii) A fast-moving vehicle causes more damage than a slow-moving vehicle when they both hit an obstacle.
18. A truck of mass $4 \times 10^4\text{kg}$ moving at a velocity 3m/s collides with another truck of mass $2 \times 10^4\text{kg}$ which is at rest. The couplings join and the trucks move off together.
 - a) State the type of collision.
 - b) Calculate the common velocity of the trucks after collision.
 - c) Calculate the loss in kinetic energy.
19. A bullet of mass 10g is shot from a gun of mass 20kg with a muzzle velocity of 100m/s . If the barrel (tube of the gun) is 0.2m long, determine;
 - i) the acceleration of the bullet.
 - ii) recoil velocity of the gun.
20. A car X of mass 1000kg travelling at a speed of 20ms^{-1} in the direction due east collides head-on with another car Y of mass 1500kg travelling at 15ms^{-1} in the direction due west. If the two cars stick together, find their common velocity after collision.

WAVES

A wave is a disturbance through a medium which transfers energy from one point to another without causing any permanent displacement of medium itself.

Waves can be seen when;

- A stone is thrown into water.
- Oscillating a spring.
- A rope is fixed at one end and then jerked at another end.

CLASSIFICATION OF WAVES:

There are two classes of waves namely;

- Mechanical waves.
- Electromagnetic waves.

MECHANICAL WAVES:

These are waves that require a material medium to transfer energy from one point to another.

These waves are produced by vibrating bodies.

These waves can't travel through a vacuum.

They normally have a low velocity.

Examples of mechanical waves include;

- Sound waves.
- Water waves.
- Waves in stretched strings.

ELECTROMAGNETIC WAVES:

These are waves that do not require a material medium to transfer energy from one point to another.

They are produced by varying electric and magnetic fields.

They can travel through a vacuum.

All electromagnetic waves travel at a speed of light ($3 \times 10^8 \text{ms}^{-1}$)

Examples of electromagnetic waves include;

- Gamma rays
- X-rays
- Radio waves
- Infrared
- Visible light
- Ultra-violet light (UV), etc

Differences between mechanical and electromagnetic waves.

Mechanical waves	Electromagnetic waves
<ul style="list-style-type: none"> ▪ They require a material medium for their transmission. ▪ They can't travel through a vacuum. ▪ They are produced by vibrating bodies ▪ They are slower. 	<ul style="list-style-type: none"> ▪ Don't require a material medium for their transmission. ▪ They can travel through a vacuum. ▪ They are produced by varying electric and magnetic fields. ▪ They are faster since they travel at a speed of light.

REPRESENTATION OF A WAVE:

Waves are normally represented in form of oscillations or cycles.

Definition:

An **oscillation** is a complete to and fro movement of a wave.

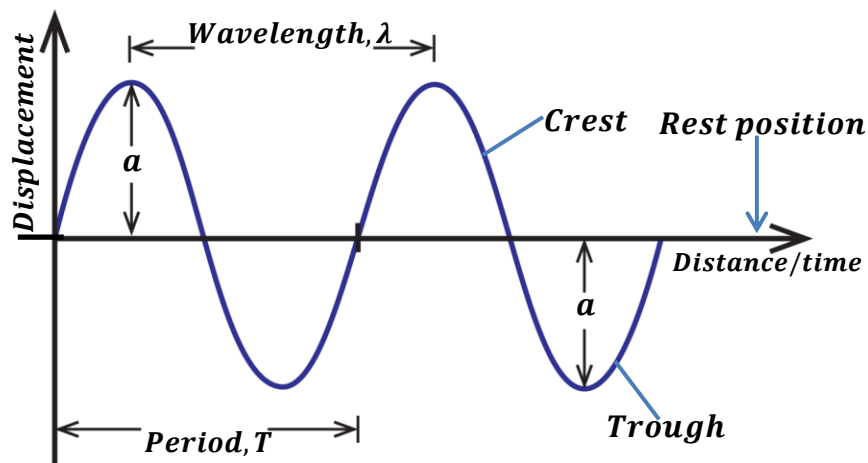
Rest position:

This is the undisturbed position of a wave.

Amplitude, a:

This is the maximum displacement of a wave particle from the rest position.

Crest:

This is the maximum displacement of a wave above the rest position.

Trough:

This is the maximum displacement of a wave below the rest position.

Wavelength, λ:

This is the distance between two successive crests or troughs of a wave.

OR

This is distance covered in one complete oscillation/cycle.

Wavelength is measured in metres.

Period, T:

This the time taken to complete one oscillation.

$$T = \frac{1}{f}$$

It is measure in seconds.

Frequency, f:

This is the number of oscillations per second.

$$f = \frac{1}{T}$$

It is measured in Hertz (**Hz**)

Wave form:

This is the shape of the wave.

Wave phase:

This is the timing of one oscillation of a wave in comparison with another oscillation of another wave.

Wave particles are in phase if they are exactly at the same point at the same time at same distance from rest position and are moving in the same direction.

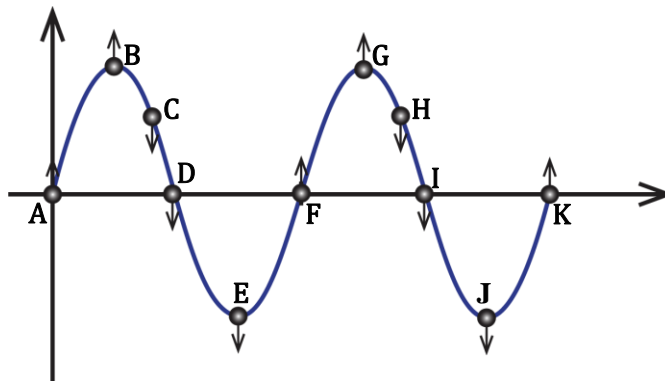

Particles A and F and K are in phase.

Particles B and G are in phase.

Particles C and F are not in phase.

Particles A and D are not in phase.

VELOCITY OF A WAVE

This is the distance travelled by a wave per unit time.

$$velocity = \frac{\text{distance}}{\text{time}}$$

Since in one complete cycle/oscillation, a wave travels a distance equal to wavelength, λ in time equal to period, T.

$$velocity = \frac{\text{wavelength}}{\text{period}}$$

$$V = \frac{\lambda}{T} \quad \text{But } T = \frac{1}{f}$$

$$\text{Therefore, } \boxed{V = \lambda f}$$

NOTE:

If the number of oscillations is not known then,

$$\text{Period, } T = \frac{t}{n}$$

Where t – time taken for n oscillations.

Examples:

1. Calculate the frequency of the wave if its velocity and wave are 5ms^{-1} and 0.5m respectively.

$$\begin{aligned} V &= f\lambda \\ 5 &= f \times 0.5 \\ f &= \frac{5}{0.5} \\ f &= 10\text{m} \end{aligned}$$

2. A vibrator of frequency 50Hz produces circular waves. If the distance between the two successive crests is 5cm . find the speed of the waves.

$$\begin{aligned} \lambda &= \frac{5}{100} = 0.05\text{m} \\ V &= f\lambda \\ V &= 50 \times 0.05 \\ V &= 2.5\text{ms}^{-1} \end{aligned}$$

3. A vibrator with a frequency of 20Hz vibrates for a distance of 25cm in 5 seconds. Find

- (i) The speed of the wave produced
(ii) Wave length of the wave produced

(i)

$$\begin{aligned} d &= \frac{25}{100} = 0.25\text{m}, & t &= 5\text{s} \\ V &= \frac{d}{t} \\ V &= \frac{0.25}{5} \\ V &= 0.05\text{ms}^{-1} \end{aligned}$$

(ii)

$$\begin{aligned} V &= f\lambda \\ 0.05 &= 20\lambda \\ \lambda &= \frac{0.05}{20} \\ \lambda &= 0.0025\text{m} \end{aligned}$$

4. A vibrator produces waves which travel a distance of 35cm in 2 seconds. If the distance between two successive crests is 5cm . find

- (i) The velocity of the waves
(ii) The frequency of the waves

(i)

$$\begin{aligned} d &= \frac{35}{100} = 0.35\text{m} & t &= 2\text{s} & \lambda &= \frac{5}{100} = 0.05\text{m} \\ V &= \frac{d}{t} \\ V &= \frac{0.35}{2} \\ V &= 0.175\text{ms}^{-1} \end{aligned}$$

(ii)

$$\begin{aligned} V &= f\lambda \\ 0.175 &= f \times 0.05 \\ f &= \frac{0.175}{0.05} \\ f &= 3.5\text{Hz} \end{aligned}$$

5. The figure below shows circular waves produced by a vibrator of frequency 32Hz. Calculate their speed.

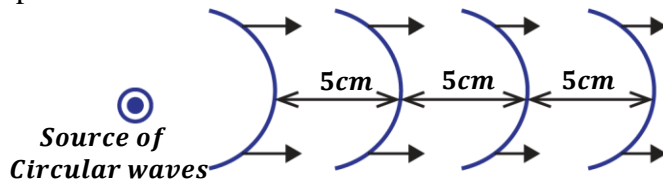

$$\text{wavelength} = \text{distance in one cycle} \text{ so } \lambda = 5\text{cm} = \frac{5}{100} = 0.05\text{m}$$

$$V = f\lambda$$

$$V = 32 \times 0.05 = 1.6\text{ms}^{-1}$$

6. A radio station produces radio waves of wavelength 10m.
- Calculate the frequency of the wave.
 - Period of the wave
 - Number of oscillations in 10s.
 - State any assumption taken.

(i)

$$\begin{aligned} V &= f\lambda \\ 3 \times 10^8 &= f \times 10 \\ f &= \frac{3 \times 10^8}{10} \\ f &= 3 \times 10^7 \text{ Hz} \end{aligned}$$

(ii)

$$\begin{aligned} T &= \frac{1}{f} \\ T &= \frac{1}{3 \times 10^7} \\ T &= 3.3 \times 10^{-8} \text{ s} \end{aligned}$$

(iii)

$$\begin{aligned} T &= \frac{t}{n} \\ 3.3 \times 10^{-8} &= \frac{10}{n} \\ n &= \frac{10}{3.3 \times 10^{-8}} \\ n &= 3.03 \times 10^8 \text{ oscillations.} \end{aligned}$$

(iv) Radio waves are electromagnetic waves so they travel at a speed of light ($3 \times 10^8 \text{ms}^{-1}$)

7. The diagram below represents a wave travelling from left to right with a velocity of 300ms^{-1}

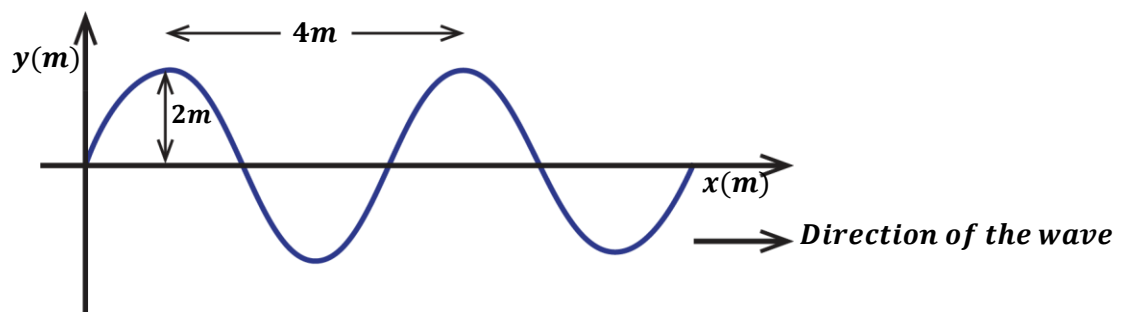

Find

- Amplitude in metres.
- Frequency of the wave.

(i)

$$a = 2\text{cm} = \frac{2}{100} = 0.02\text{m}$$

(ii)

$$V = 300\text{ms}^{-1}, \lambda = 4\text{m}$$

$$V = f\lambda$$

$$300 = f \times 4$$

$$f = \frac{300}{4}$$

$$f = 75\text{Hz}$$

8. The wave below has a velocity of 320ms^{-1} .

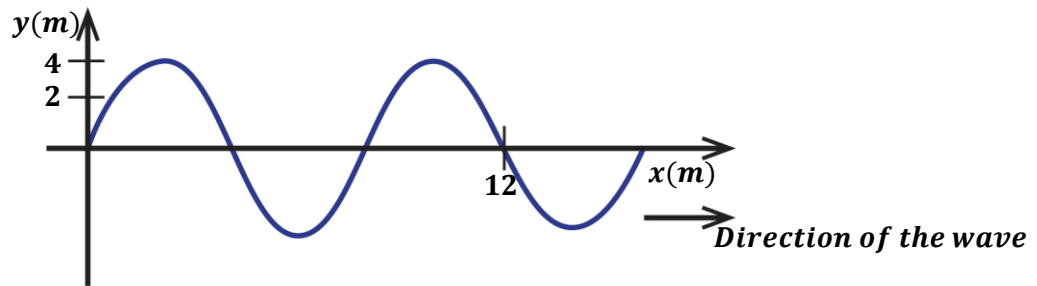

Find;

- (i) The amplitude.
- (ii) Wavelength.
- (iii) Frequency of the wave

(i) **Amplitude, $a = 4\text{m}$**

(ii)

$$\lambda = \text{distance by one oscillation.}$$

$$\frac{3}{2} \text{ oscillations} = 12\text{m}$$

$$1 \text{ oscillation} = \frac{12}{3/2} = 8\text{m}$$

therefore, $\lambda = 8\text{m}$

(iii)

$$V = 320\text{ms}^{-1}, \lambda = 8\text{m}$$

$$V = f\lambda$$

$$320 = f \times 8$$

$$f = \frac{320}{8}$$

$$f = 40\text{Hz}$$

NOTE:

If the distance, d between n successive crests or troughs then;

$$\text{Wavelength, } \lambda = \frac{\text{distance, } d}{n-1}$$

$$\lambda = \frac{d}{n-1}$$

9. If the distance between 9 successive crests is 48cm.find the wavelength of the wave.

$$d = 48\text{cm} = \frac{48}{100} = 0.48\text{m}, \quad n = 9$$

$$\lambda = \frac{d}{n-1}$$

$$\lambda = \frac{0.48}{9-1}$$

$$\lambda = 0.06$$

10. Water waves are produced at a frequency of 50Hz and the distance between 10 successive troughs is 18cm. Calculate the velocity of the waves.

$$d = 18\text{cm} = \frac{18}{100} = 0.18\text{m},$$

$$n = 10$$

$$\lambda = \frac{d}{n-1}$$

$$\lambda = \frac{0.18}{10-1}$$

$$\lambda = 0.02\text{m}$$

$$V = f\lambda$$

$$V = 50 \times 0.02 = 1\text{ms}^{-1}$$

WAVE MOTION

When a wave is setup in a medium, the particles of the medium vibrate from their rest position while carrying energy. The energy is passed from one particle to another until when the final destination is reached.

Types of waves according to their motion:

There are two types of waves which include:

- Progressive waves.
- Stationary/standing waves.

PROGRESSIVE WAVES

These are waves which carry energy away from the source and spread out continuously.

There are two forms of progressive waves namely;

- Transverse waves.
- Longitudinal waves.

TRANSVERSE WAVES

These are waves in which particles of a medium vibrate perpendicular to the direction of propagation of a wave.

They form crest and troughs.

Examples include;

- ✓ Water waves.
- ✓ Waves from vibrating strings.
- ✓ Electromagnetic waves.

A transverse wave is represented in the figure below.

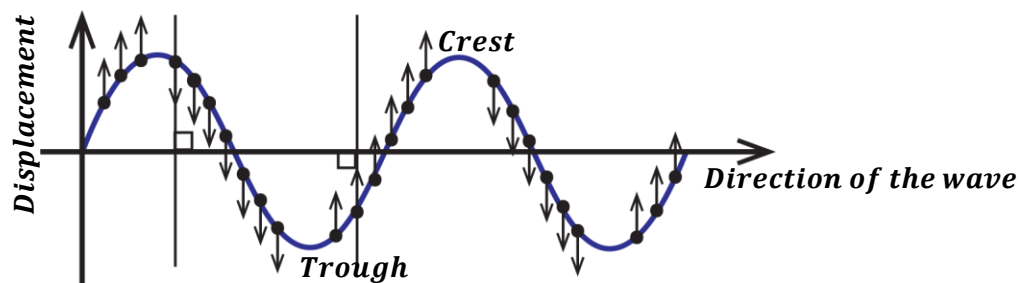

LONGITUDINAL WAVES:

These are waves in which particles of a medium vibrate parallel to the direction of propagation of a wave.

OR

These are waves in which particles of a medium vibrate in the same direction as the direction of propagation of a wave.

Longitudinal waves form compressions and rare factions.

Examples include;

- ✓ Sound waves
- ✓ Waves from compressed or stretched strings.

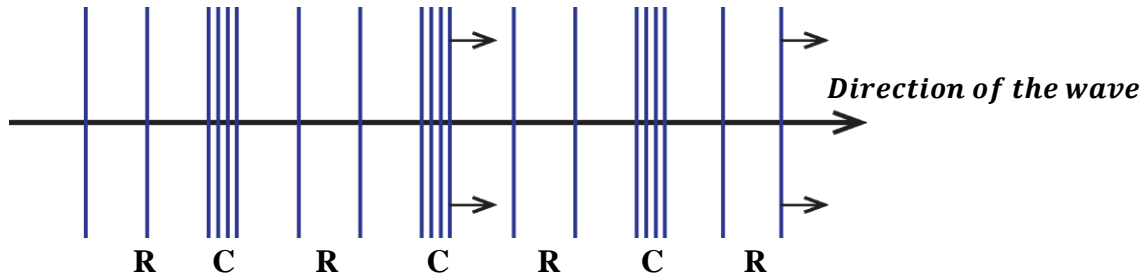

Where **C** – Compressions
R – Rare factions

Compression: This is a region where particles of a wave are close together.

Rare faction: This is a region where particles of a wave are far apart from each other.

Longitudinal waves

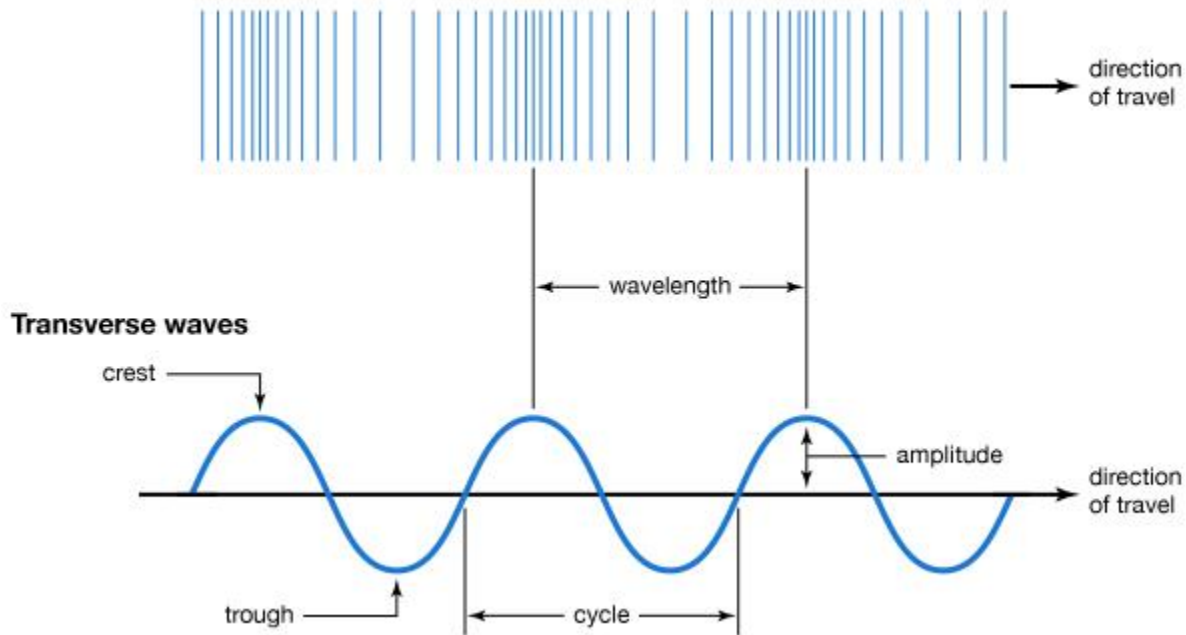

NOTE:

Wavelength of a longitudinal wave is the distance between two successive compressions or rarefactions of a wave.

Example: The distance between two successive compressions is 20m. Find the speed of a wave if its frequency is 16Hz.

$$\begin{aligned}\lambda &= 20m, & f &= 16Hz \\ V &= f\lambda \\ V &= 16 \times 20 \\ V &= 320ms^{-1}\end{aligned}$$

DIFFERENCES BETWEEN LONGITUDINAL AND TRANSVERSE WAVES.

Transverse waves	Longitudinal waves
<ul style="list-style-type: none"> ▪ Particles vibrate perpendicular to direction of propagation of a wave. ▪ Forms crests and troughs. ▪ Distance between successive crests or troughs is the wavelength. 	<ul style="list-style-type: none"> ▪ Particles vibrate parallel to direction of propagation of a wave. ▪ Forms compressions and rare factions. ▪ Distance between successive compressions or rare factions is wavelength.

Question; State differences between light waves (transverse) and sound waves (longitudinal)

ELECTROMAGNETIC SPECTRUM/BAND

Electromagnetic waves are categorized in terms of their wavelength.

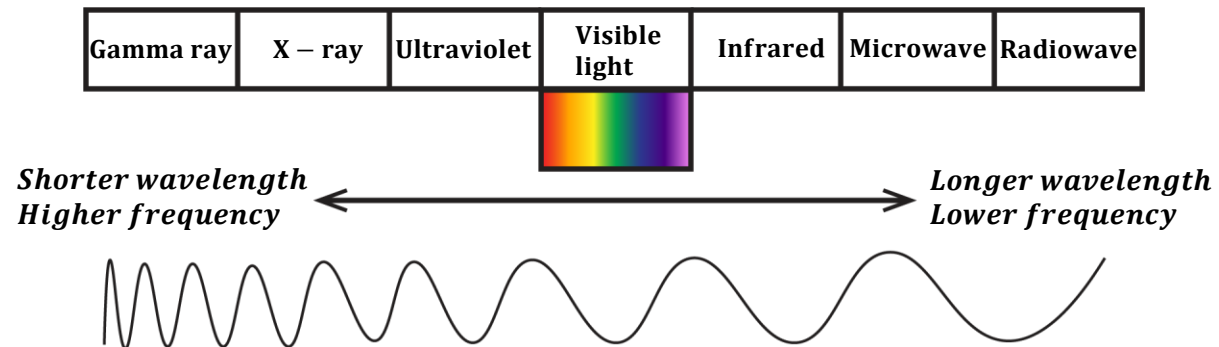
Gamma rays:

- They have the shortest wavelength.
- They have the highest frequency.
- They have the greatest penetrating power.
- They destroy body tissues if exposed for a long time.
- They harden rubber solutions.
- They are emitted from radioactive substances.

X-rays:

- They have a longer wavelength than the gamma rays.
- They are produced by fast moving electrons (cathode rays) on hitting the metal target in the X-ray tube.
- They destroy body tissues if exposed for a long time.
- They are used in industries to detect leakages in pipes and in hospitals to detect fractures of bones.

Ultra violet light (UV):

- These are radiations got from very hot bodies (e.g. sun) and also through gases (e.g. mercury vapour)
- It causes sun burn.
- Causes blindness if there is too much exposure.
- It causes electrons to give off electrons by the process called photo-electric emission.
- Used to detect forged bank notes.

Visible light:

- This is the light that enables us to see.
- It's got from lamps, flames etc.
- It determines the colour and appearance of an object.
- It makes objects appear bent due to refraction.
- Used in photosynthesis.

Infrared:

- All objects emit infrared radiations.
- They cause the body temperature to rise because most of the heat in light is carried by infrared. Infrared enables us to get vitamin D.
- Used in production of night vision cameras.
- Used in T.V remotes.

Micro-waves:

- They are used to cook food in micro-ovens.
- They transmit information in radar systems.

Radio waves:

- They are produced when electrons are accelerated in an aerial.
- They have the longest wavelength and shortest frequency.
- Used in broadcasting radio and T.V signals.

Properties of electromagnetic waves:

- They are transverse waves.
- They can travel through a vacuum.
- They travel at a speed of light $(3 \times 10^8)ms^{-1}$
- They carry energy.
- They do not need a material medium for their propagation.
- They can be reflected, refracted and diffracted.

Similarities between mechanical waves and electromagnetic waves:

- Both carry energy from one place to another.
- Both are subject to interference.
- Both can be reflected, refracted and diffracted

WAVE FRONT

This is the surface of a wave in which every particle is at the same distance from the source of the wave.

OR

This is a line that joins particles of a wave that are in phase.

There are two types of wave fronts namely;

Circular wave fronts

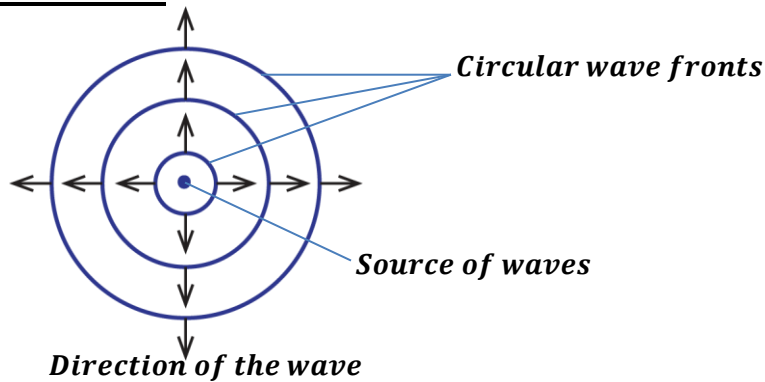

Plane/straight wave fronts

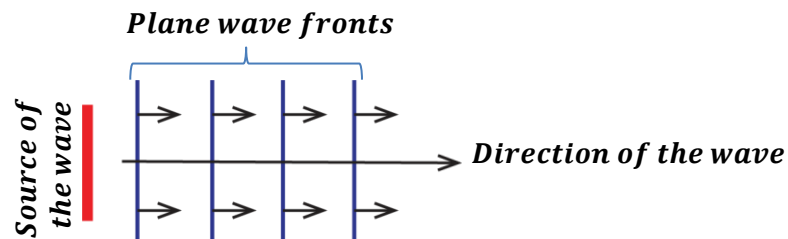

NB: The distance between successive wave fronts is equal to wavelength.

RIPPLE TANK

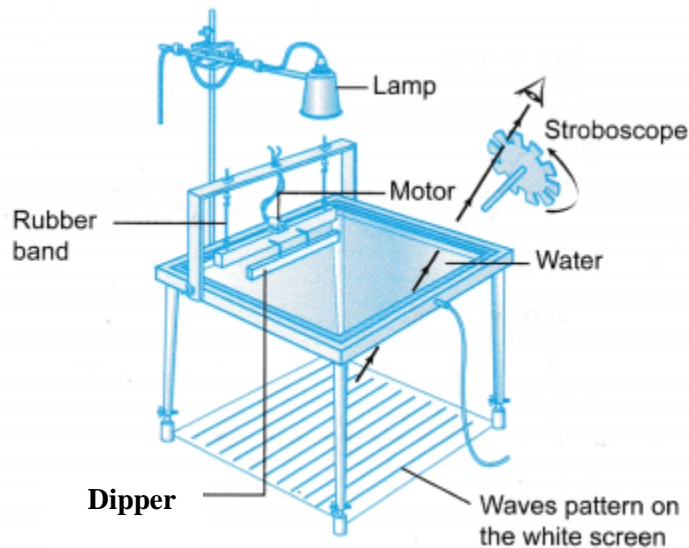

A ripple tank is an instrument used to study the properties of water waves. It has a transparent glass trough containing water.

The images of the waves are formed on the white screen placed below it.

The ripple tank is illuminated with a source of light (lamp) in order to observe the wave patterns clearly.

The waves are produced by means of a dipper when it hits the surface of the water.

The dipper is vibrated by an electric motor which is connected to it.

The stroboscope helps to make the waves stationary so they can be studied very well.

How to produce wave fronts:

- Circular wave fronts are produced when a spherical dipper is vibrated on the surface of water by an electric motor.
- Plane wave fronts are produced when a straight rod dipper is vibrated on the surface of water by an electric motor.

PROPERTIES OF WAVES

Waves undergo the following properties;

- Reflection.
- Refraction.
- Diffraction.
- Interference.

REFLECTION OF WAVES.

This is the bouncing off of waves as they meet a barrier.

The shape of the reflected waves depends on the shape of the barrier.

Reflection of plane waves:

(a) On a plane surface.

Plane wave fronts are reflected as plane wave fronts.

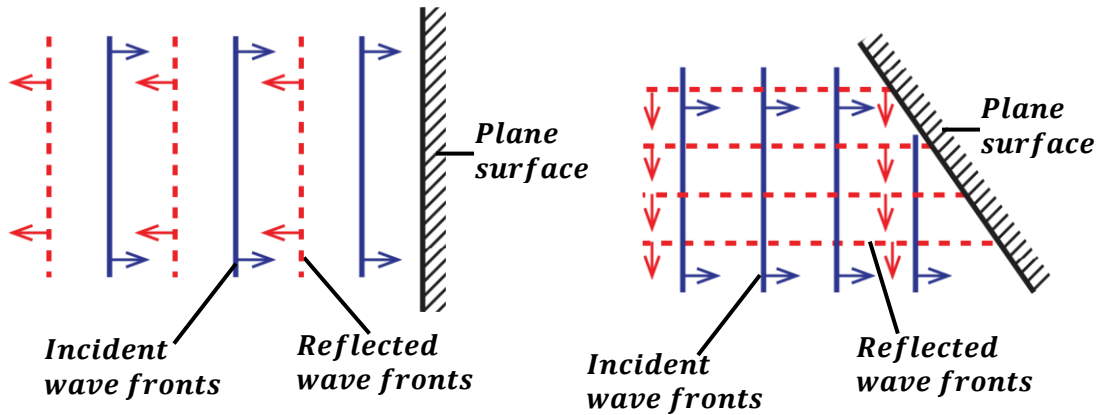
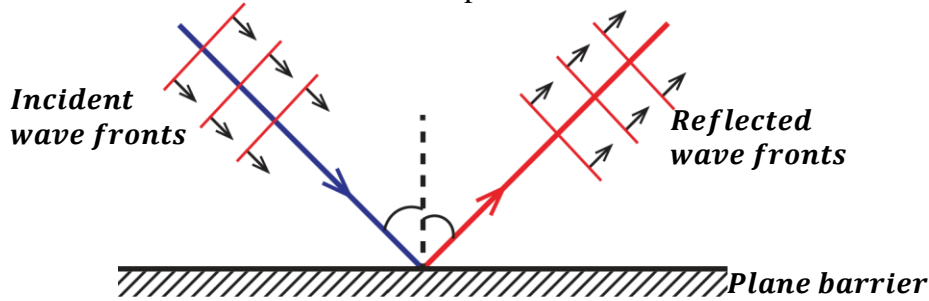

(b) On curved surfaces.

Plane wave fronts incident on a concave reflector are reflected as concave wave fronts.

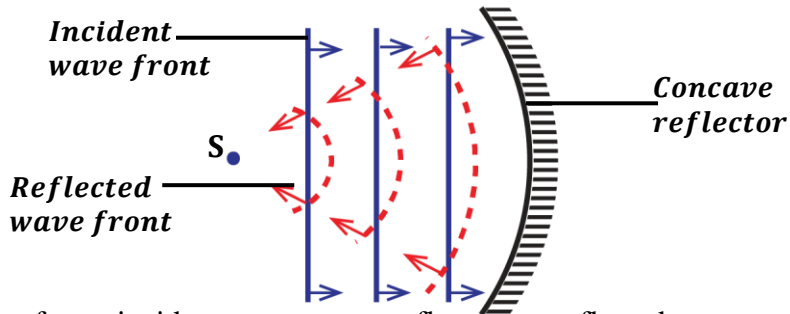

Plane wave fronts incident on a convex reflector are reflected as convex wave fronts.

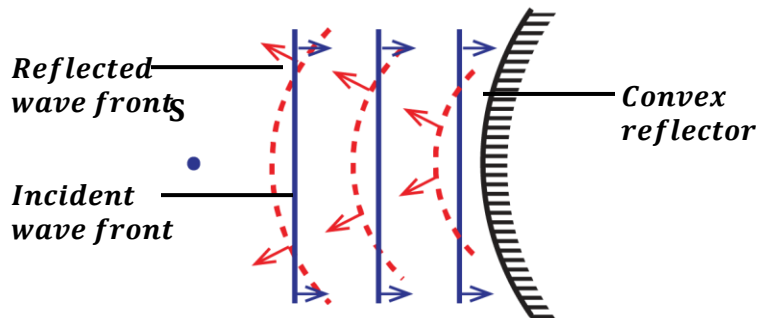

Reflection of circular waves;
(a) On plane surfaces.

Concave wave fronts incident on a plane surface are reflected as convex wave fronts.

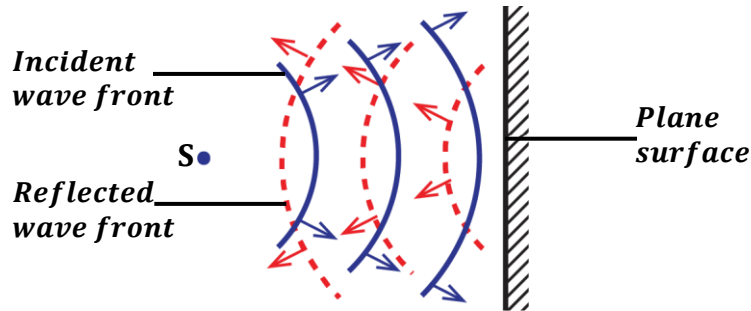

Convex wave fronts incident on a plane surface are reflected as concave wave fronts.

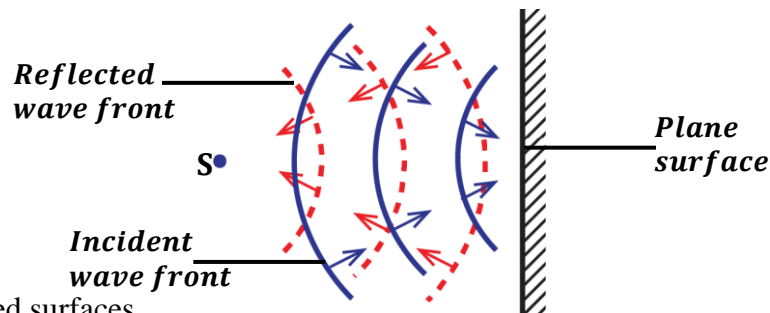
(b) On curved surfaces.

(i) **Concave reflector:** Concave circular wave fronts incident on a concave reflector are reflected as plane wave fronts

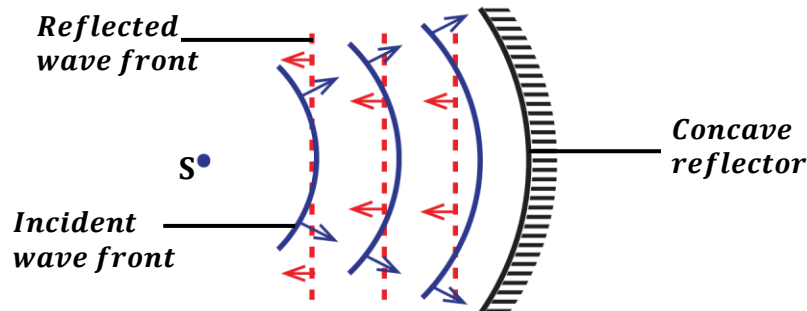

Convex circular wave fronts incident on a concave reflector are reflected as concave wave fronts.

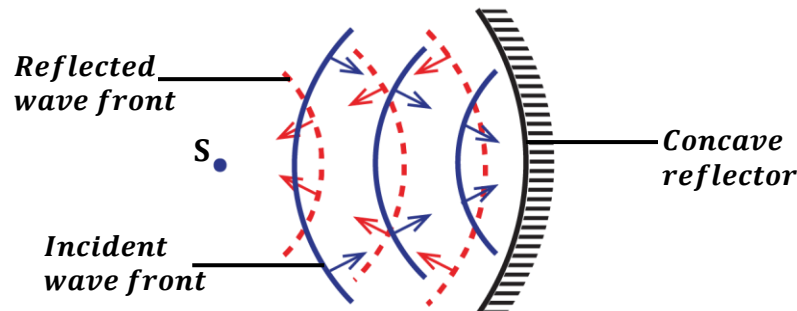

- (ii) **Convex reflector:** Convex circular wave fronts incident on a convex reflector are reflected as plane wave fronts.

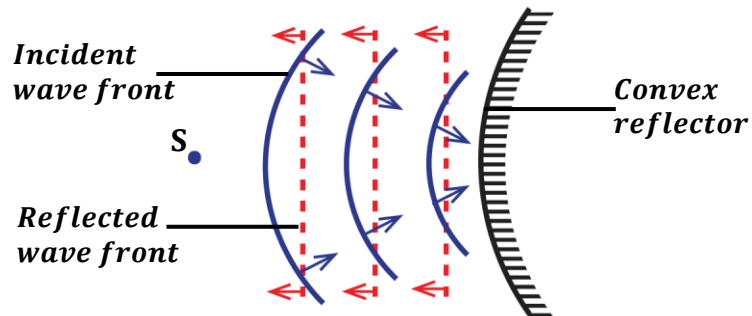

Concave circular wave fronts incident on a convex reflector are reflected as convex circular wave fronts.

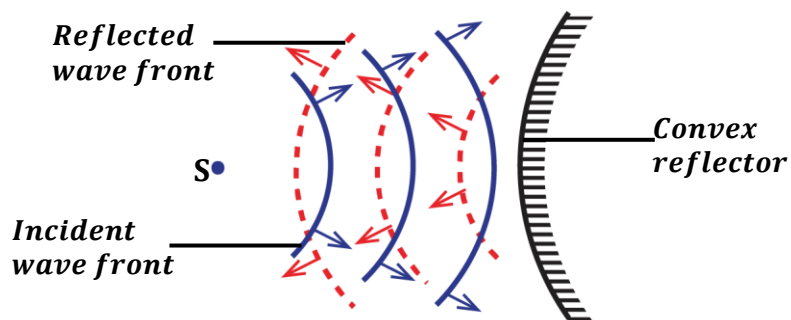

REFRACTION OF WAVES:

This is the change in direction of a wave as it moves from one medium to another of different depth.

Water waves can be refracted in a ripple tank by placing a sheet of glass in water to make it shallow.

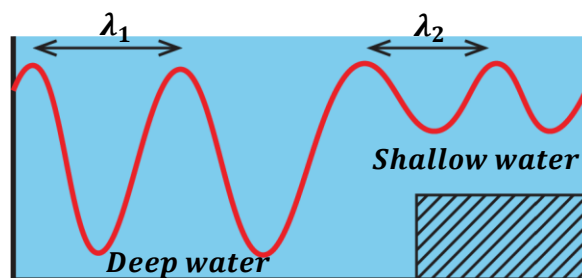

When a wave is refracted, there is change in wavelength and speed but frequency remains constant.

NOTE:

When waves move from deep water to shallow water, it's;

- Wavelength decreases
- Speed decreases in the shallow water.
- Frequency remains constant
- Waves bend towards the normal.

Wave fronts become close to one another in shallow water than in deep water as shown in the diagram below.

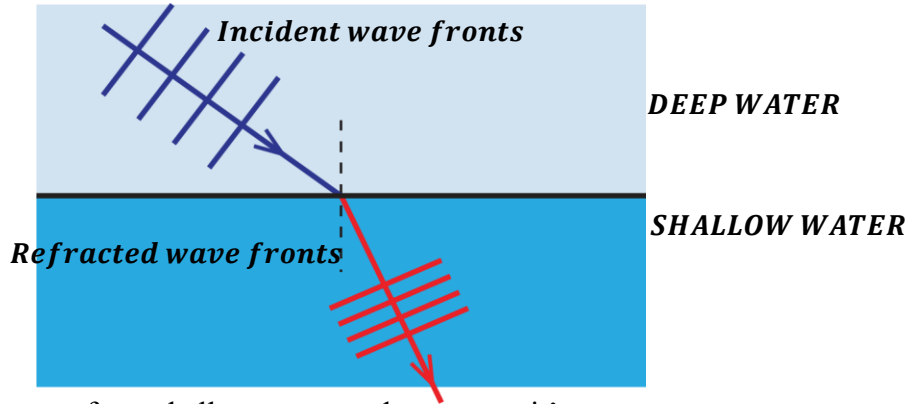

When waves move from shallow water to deep water, it's;

- Wavelength increases.
- Speed increases in the deep water.
- Frequency remains constant
- Waves bend away from the normal.

Wave fronts become further apart from one another in deep water than in shallow water as shown in the diagram below.

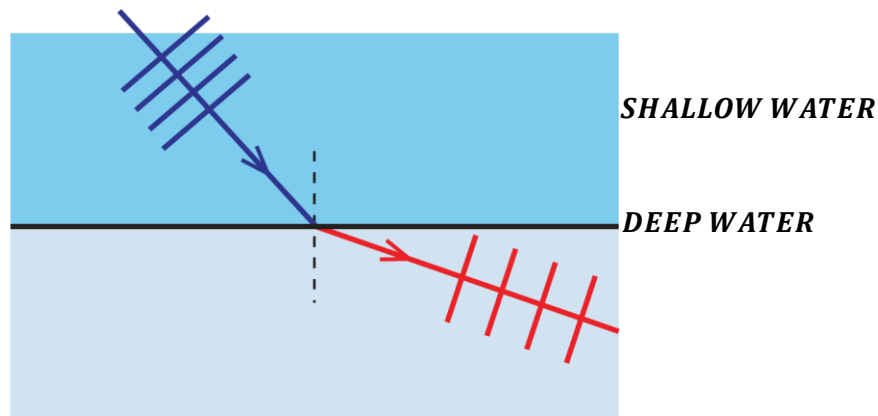

$$\text{Refractive index of water} = \frac{\text{velocity in deep water } (V_1)}{\text{velocity in shallow water } (V_2)}$$

$$n = \frac{\lambda_1 f}{\lambda_2 f}$$

$$n = \frac{\lambda_1}{\lambda_2}$$

Refraction of plane wave fronts at lenses:

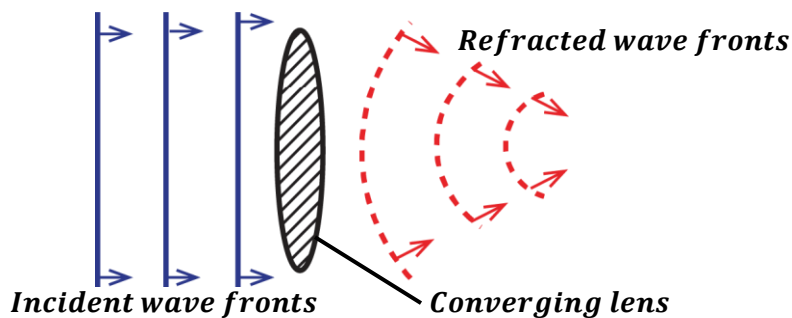

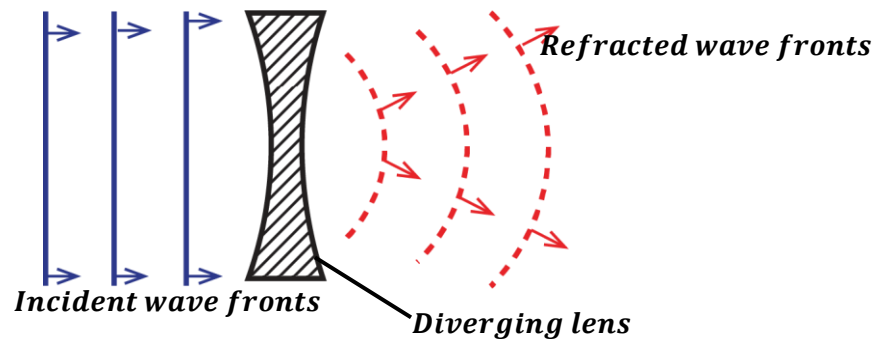

DIFFRACTION OF WAVES:

This is the spreading of waves as they pass through holes, around corners or edges of an obstacle.

In a ripple tank, diffraction can be made by placing two barriers with a gap between them.

- If the gap between two barriers is small (narrow), then plane wave fronts with a circular shape and then spread out.
- If the gap between the two barriers is wide, then plane wave fronts emerge when slightly bent at the edges.

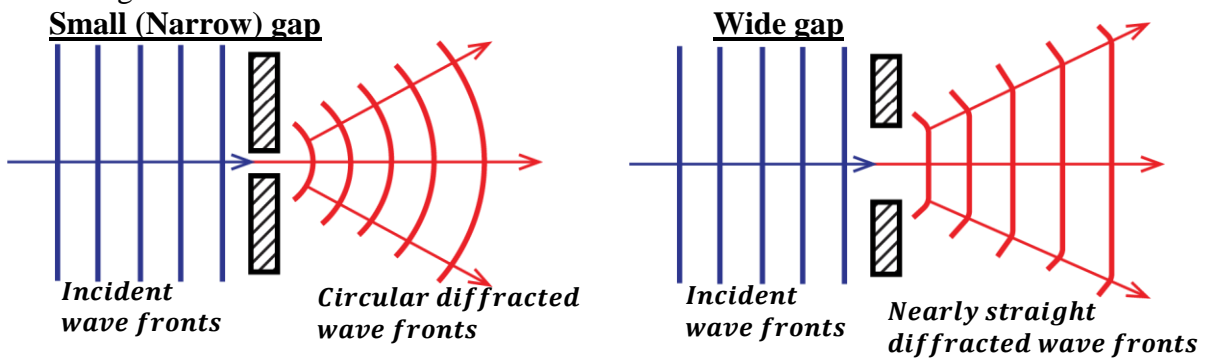

At a corner or edge of an obstacle:

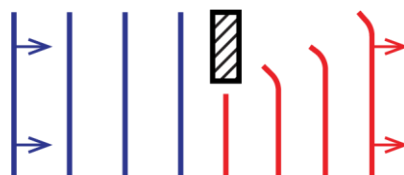

EFFECT OF LONG AND SHORT WAVELENGTH:

- Waves are greatly diffracted (spread out more) when the wavelength is longer and they are less diffracted (spread out less) when the wavelength is small.

QUESTION 1: Explain why sound can be heard in corners yet light can't be seen in corners (corners are always dark)

This is because sound waves are more diffracted than light waves since they have a longer wavelength than the light waves. Therefore, light can't spread out to all the corners of the room since it has a shorter wavelength hence the darkness.

- Waves of short wavelength are easily scattered than waves of long wavelength i.e. blue light are more scattered when it strikes different molecules than red light.

QUESTION 2: Explain why the sky appears red during sun-rise or sun-set.

When rising/setting of the sun, light rays travel a longer distance in the earth's atmosphere to reach our eyes. So blue light scatters away easily and is removed before reaching our eyes. Therefore, only light of longer wavelength reach straight to our eyes and that light is red.

QUESTION 3: Explain why the sky appears blue during day-time.

During day, the sun is overhead the atmosphere so light travels a shorter distance to reach our eyes. The blue light which has a short wavelength is easily scattered throughout all directions in the atmosphere hence the blue appearance of the sky.

When two or more gaps are in a barrier, the waves will be diffracted and interference occurs.

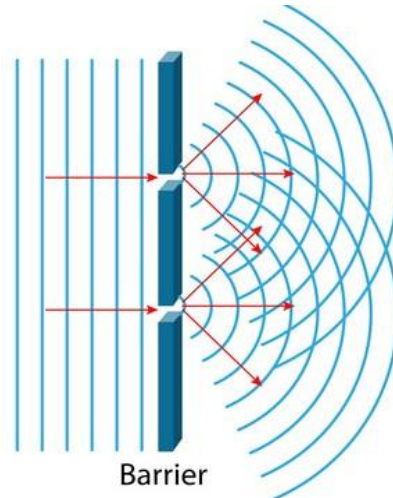

INTERFERENCE OF WAVES:

This is the superposition of two identical waves travelling in the same direction to form a single wave with lower or greater amplitude.

OR

This is the overlapping of two identical waves travelling in the same direction to form a single wave with lower or greater amplitude.

Conditions for interference to occur:

- The two waves should have the same frequency.
- The two waves should have the same speed.
- The two waves should have the same wave length.
- The two waves should have the same amplitude.
- The two waves should be moving in the same direction

Types of interference:

There are two types of interference namely;

- Constructive interference.
- Destructive interference.

CONSTRUCTIVE INTERFERENCE

This is the type of interference which occurs when a crest of one wave meets a crest of another wave or a trough of one wave meets a trough of another wave forming a single wave with greater amplitude.



For light: Constructive interference would give increased brightness.

For sound: Constructive interference would give increased loudness.

DESTRUCTIVE INTERFERENCE

This is the type of interference which occurs when a crest of one wave meets a trough of another wave forming a single wave with no amplitude.

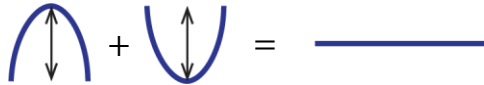

For light: Destructive interference gives darkness or reduced brightness.

For sound: Destructive interference gives reduced loudness or no sound at all.

NOTE:

When two sources of waves are placed close to each other, both destructive and constructive interference occur.

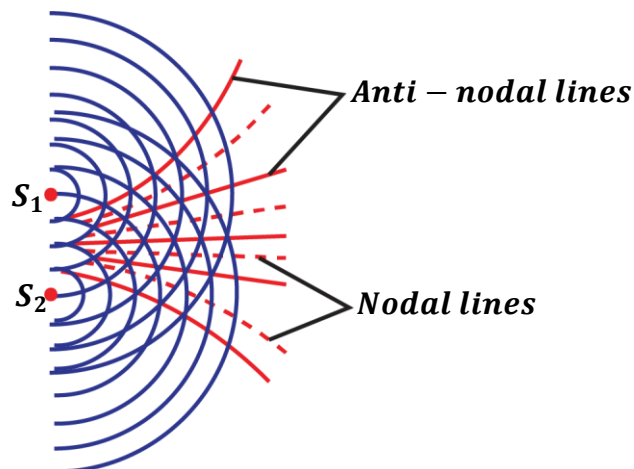

Anti-nodal lines: These are lines joining points of constructive interference.

Nodal lines: These are lines joining points of destructive interference.

EXERCISE:

1. The wave length of a radio wave is 10m. Given that the speed of the radio wave is $3 \times 10^8 \text{ms}^{-1}$. Find the frequency and period of the wave
Ans: ($3.0 \times 10^7 \text{Hz}$, $3.33 \times 10^{-8} \text{s}$)
2. The frequency of a radio wave is $6.0 \times 10^7 \text{Hz}$. Given that the speed of the radio wave is $3 \times 10^8 \text{ms}^{-1}$. Find the wave length of the wave.
Ans: (5m)
3. Water waves travel a distance of 36cm in 6 seconds and the separation between two successive troughs is 3.0cm. Calculate the velocity and the frequency of the waves
Ans: ($6 \times 10^{-2} \text{ms}^{-1}$, 2Hz)
4. A source produces waves which travel a distance of 140cm in 0.08 seconds and the separation between two successive crests is 20cm. Calculate the velocity and the frequency of the waves.
Ans: (17.5ms^{-1} , 87.5Hz)
5. Water waves of frequency of 6Hz travel a distance of 24m in 10 seconds. Calculate the velocity and wave length of the waves
Ans: (2.4ms^{-1} , 0.4m)
6. A vibrator in a ripple tank vibrates at 500Hz. If the distance between 10 successive crests is 37.8cm. Calculate the wave length and the velocity of the waves
Ans: (4.2cm, 21.0ms^{-1})
7. A vibrator produces waves which travel a distance of 315cm in 20 seconds and the separation between two successive crests is 20cm. Calculate the velocity and the frequency of the waves
Ans: (0.1575ms^{-1} , 0.7875Hz)
8. The frequency of a sound wave is $6.8 \times 10^5 \text{Hz}$. Given that the speed of the sound wave is 340ms^{-1} . Find the wave length of the wave.
Ans: ($5 \times 10^{-4} \text{m}$)

SOUND WAVES

This is the form of energy produced by vibrating objects.

Sound waves are produced when particles of a medium are set into vibrations e.g. plucking a guitar string, drumming etc.

Sound waves are longitudinal waves and mechanical waves so they require a medium for their transmission e.g. solids, liquids and gases.

PROPERTIES OF SOUND WAVES:

- They are longitudinal waves.
- They require a material medium to travel so they can't travel through a vacuum.
- They can be reflected, refracted and diffracted.
- They undergo interference.
- They travel at a lower speed.



TRANSMISSION OF SOUND

Sound is a mechanical wave; therefore, it requires a material medium for its transmission so it cannot travel through a vacuum.

Experiment to show that sound waves need a material medium for its transmission:

(Describe an experiment to show that sound is a mechanical wave)

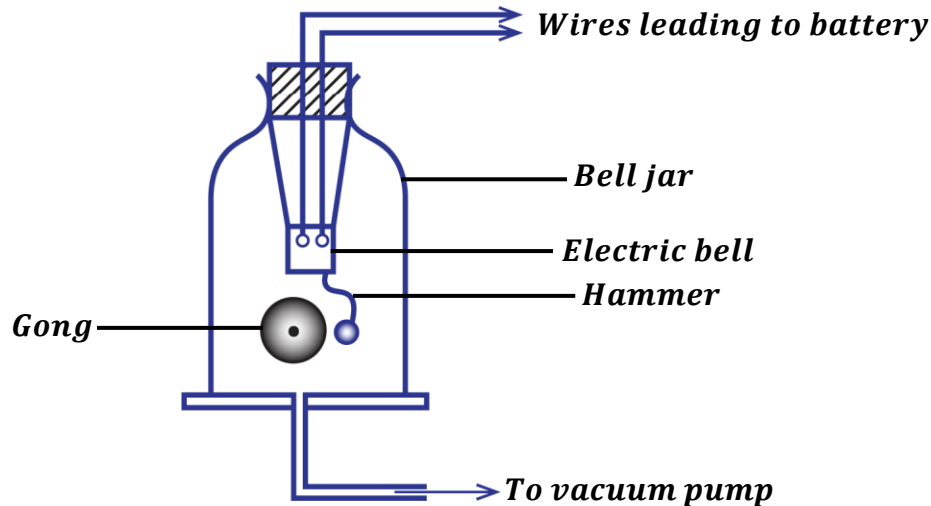

- When an electric bell inside a bell jar is switched on, a loud sound is heard.
- When the air inside the bell jar is gradually removed by means of a vacuum pump, the loudness starts to fade out/ die away.
- When all the air is completely removed from the bell jar, no sound is heard even though the hammer is seen hitting the gong.
- When air is again allowed in the bell jar, sound is heard again.
- This shows that sound requires a material medium for its transmission.

Factors that affect the speed of sound in a medium:

The speed of sound in a medium depends on; -

Temperature:

Increase in temperature increases the speed of sound. This is because temperature increases the speed of molecules of the medium.

Sound travels faster in hot air than in cold air.

Density of medium:

Speed of sound is more in denser medium than in a less dense medium.

Sound travels faster in solids than in liquids and gases. This is because molecules of a solid are closely packed together; therefore, movement of sound energy from one molecule to another is very easy.

Wind:

Speed of sound is increased if sound travels in the same direction of wind.

Altitude:

Sound travels faster at lower altitude and slower at higher altitudes because temperature is higher at low altitudes than at high altitudes.

Humidity:

Humidity is the amount of water vapour in the air.

The higher the humidity, the higher the speed of sound.

QUESTION: Explain why a person hears sound of a moving train at a distance further away from where he is when he places his ears on the rails.

The rails are solids, sound from the train travels faster in solids because the molecules of solids are closely packed together so it is easy for sound to move from one molecule to another.

REFLECTION OF SOUND WAVES:

This is the bouncing off of sound waves as they meet a barrier.

Laws of reflection of sound:

1st law: The incident wave, reflected wave and the normal at the point of incidence all lie in the same plane.

2nd law: The angle of incidence of the wave is equal to angle of reflection of the wave.

ECHOES

An echo is a reflected sound.

Echoes are produced when sound waves are move to and fro from the reflecting surface e.g. on walls, mountains, etc.

The time taken before an echo returns back depends on; -

- Distance from the reflecting surface.
- Speed of sound in the medium.

QUESTION: Explain why echoes are not heard in small rooms.

In small rooms, echoes are not heard because reflected sound from the walls of the room returns very quickly and mix up with the original sound so the ear cannot differentiate between the two sounds.

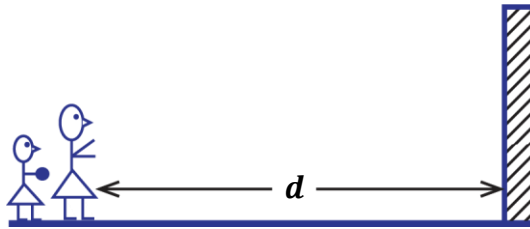
EXPERIMENT TO MEASURE THE SPEED OF SOUND IN AIR BY ECHO METHOD

- Two people stand at a distance, d from a tall vertical wall.
- One person claps and the other immediately starts a stop clock.
- On hearing the echo, a stop clock is stopped and time, t is noted.
- The speed of sound is then calculated from;

$$\text{speed, } V = \frac{2d}{t}$$

EXAMPLES:

1. A man stands at 495m away from a cliff and makes a loud sound, he hears the echo after 3 seconds. Calculate the speed of sound.

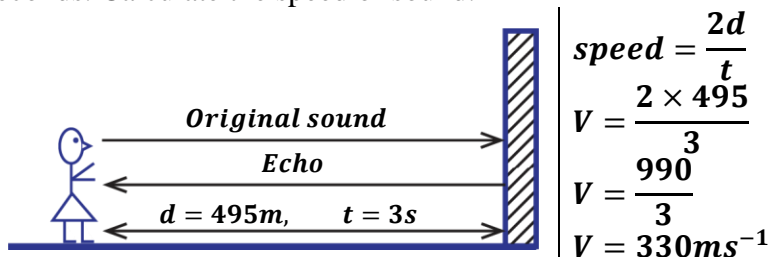

2. A girl stands 34m away from a wall. She makes sound and hears an echo 0.2seconds after. Find the velocity of sound.

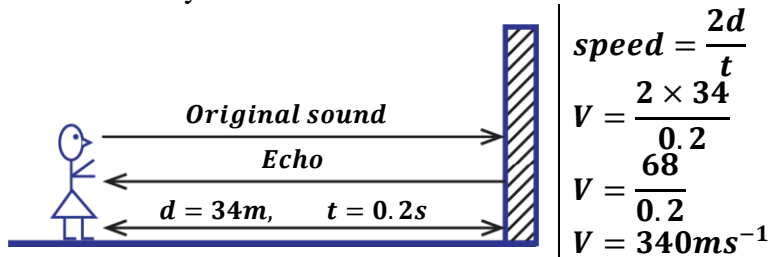

3. A gun was fired and an echo from a cliff was heard 8 seconds later. If the velocity of sound is 340ms^{-1} , how far was the gun from the cliff.

$$\begin{aligned} V &= \frac{2d}{t} \\ 340 &= \frac{2d}{8} \\ d &= \frac{340 \times 8}{2} \\ d &= 1360\text{m} \end{aligned}$$

4. A man stands between two cliffs and makes a loud sound. He hears the first echo after one second and the second echo after 2 seconds. Find the distance between the two cliffs if the speed of sound in air is 330ms^{-1} .



For first echo;

$$v = \frac{2d_1}{t_1}$$

$$330 = \frac{2d_1}{1}$$

$$d_1 = 165\text{m}$$

For second echo;

$$v = \frac{2d_2}{t_2}$$

$$330 = \frac{2d_2}{2}$$

$$d_2 = 330\text{m}$$

Total distance

$$d = d_1 + d_2$$

$$d = 165 + 330$$

$$d = 495\text{m}$$

5. A man is standing midway between two cliffs. He claps his hands and hears an echo after 3 seconds. Find the distance between the two cliffs. (speed of sound in air is 330ms^{-1})

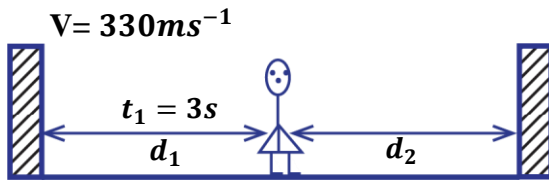

$v = 330\text{ms}^{-1}$

$$v = \frac{2d_1}{t_1}$$

$$330 = \frac{2d_1}{3}$$

$$d_1 = 495\text{m}$$

Total distance

$$d = d_1 + d_2$$

$$d = 495 + 495$$

$$d = 990\text{m}$$

6. A sound wave of frequency 200Hz is produced 300m away from a high wall. If the echo is received after 2s . Find the wavelength of the sound wave.

$$f = 200\text{Hz}, d = 300\text{m}, t = 2\text{s}$$

$$v = \frac{2d}{t}$$

$$v = \frac{2 \times 300}{2}$$

$$v = 300\text{ms}^{-1}$$

$$v = f\lambda$$

$$300 = 200 \times \lambda$$

$$\lambda = 1.5\text{m}$$

EXERCISE:

- A person standing 99m from a tall cliff claps his hands and hears an echo 0.6s later. Calculate the velocity of sound in air.
Ans: (330ms^{-1})
- A gun was fired and an echo from the cliff was heard 8s later. If the velocity of sound is 330m/s , how far was the gun from the cliff?
Ans: (1320m)
- A girl standing between two cliffs hears the first echo after 2s and hears another after a further 3s . If the velocity of sound is 330m/s , calculate the distance between the two cliffs.
Ans: (1155m)
- A child stands between 2 cliffs and makes a loud sound, if the child hears the first echo after 1.5s and the second after 2s . Find the distance between the two cliffs if the speed of sound in air is 330m/s .
Ans: (560m)

- A boy standing between two cliffs **A** and **B** claps his hands and hears the first echo from **A** after **4s** and the second echo from **B** after **5s**. If the velocity of sound in air is **330m/s**, find the distance between **A** and **B**.
- A sound wave is produced 600m away from a high wall. If an echo is received after 4 seconds. Find the frequency of sound wave with the wavelength of 2m.
- A man standing midway between two cliffs makes sound. He hears the first echo after 3s. Calculate the distance between the two cliffs. (velocity of sound is 330m/s)
- A man stands between two cliffs and fires a gun. He hears the first echo after 2 seconds and second echo after $3\frac{1}{2}$ seconds. Calculate the distance between the two cliffs. (speed of sound in air is 330m/s)

USES/APPLICATION OF ECHOES:

- Used in measurement of speed of sound.
- Used in echo sounding.
- Used in ultrasound scanning e.g. scanning womb in pregnant women.
- Used in radar equipment e.g. determining speed of vehicles by traffic officers.

ECHO SOUNDING:

Echo sounding is used in measurement of depth of a sea.

The device used is called an echo sounder.

An echo sounder consists of a transmitter and a hydrophone (microphone)

MEASUREMENT OF DEPTH OF A SEA

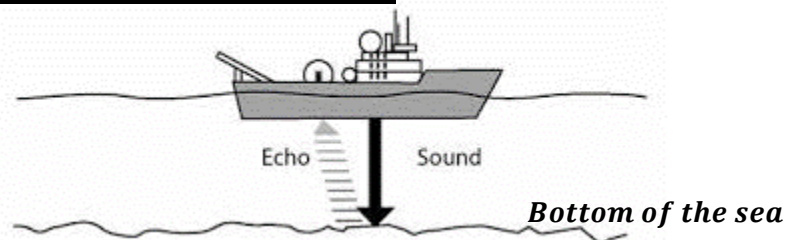

- The transmitter of an echo sounder sends out sound of very high frequency to the bottom of the sea at regular time intervals.
- The echo from the bottom of sea is received by the hydrophone which is connected to an electric timing circuit.
- The circuit automatically calculates the depth of sea from the graph plotted.

ULTRASONIC SOUNDS:

This is the sound of very high frequency which the human can't hear.

The human ear has a range of sound frequencies which it can hear.

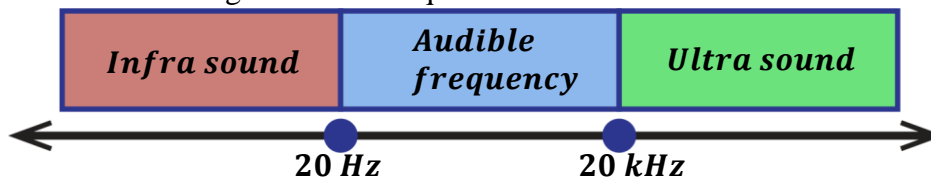

The lowest limit of audibility of human ear is 20Hz and the highest limit of audibility is 20 kHz. Therefore, sounds above 20 kHz cannot be heard by the ear.

Applications of ultrasonic sounds:

- They are used in measuring the depth of the sea.
- They are used in ultrasonic scanning e.g. scanning the womb of a pregnant woman.
- They enable bats and dogs to communicate and navigate.

The bats send out repeated ultrasonic sounds, hear and process the echo. This enables them to;

- ✓ Distinguish between an obstacle and flying insects.
- ✓ Determine direction, speed and size of flying objects

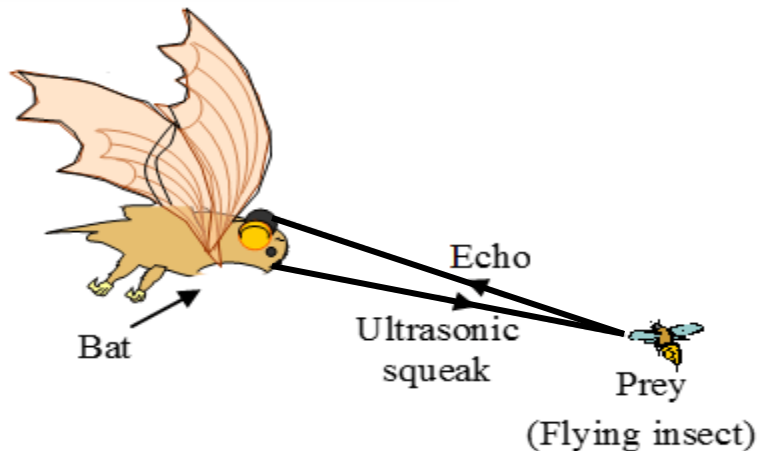
**REVERBERATION**

This occurs in large halls with many reflecting surfaces or walls where many echoes are produced due to multiple reflections. Therefore, sound lasts longer and it appears as if it is prolonged.

If the time taken to hear the echo is less than 0.1s, the human ear cannot distinguish between the original sound and the echo. If the time is just 0.1s, the original sound appears to be prolonged. This prolonged sound is called reverberation.

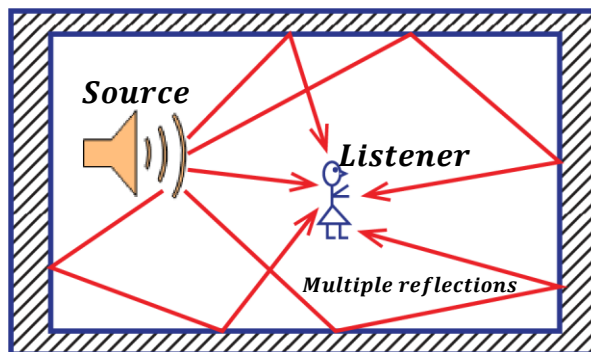
**Definition:**

Reverberation is the prolonged sound due to multiple reflections.

Advantage of reverberation:

- Reasonable reverberation makes speeches audible.

Disadvantage of reverberation:

- Unreasonable reverberation produces disorganized sound so sound becomes unclear.

Reverberation in large halls is minimized by using sound absorbing materials e.g. soft boards, curtains, carpets and cushioning seats.

QUESTION: Explain why reverberation time in a church filled with people is less than when the church is empty.

In an empty church, only the roof, walls, floor and furniture can absorb the sound but when the church is filled with people, human bodies and clothes are included to absorb sound.

REFRACTION OF SOUND WAVES:

Refraction occurs when the speed of sound waves changes as it crosses the boundary between two media. The speed of sound is affected by temperature.

Refraction of sound waves during day:

During day, air around the ground is warm (less dense) and air above the ground is cold (more dense). The sound waves move from a less dense medium to a more dense medium hence they are refracted away from the ground thus moving upwards.

This explains why;

- Sound is not easily heard during day.
- Radio signals are not clear during day.

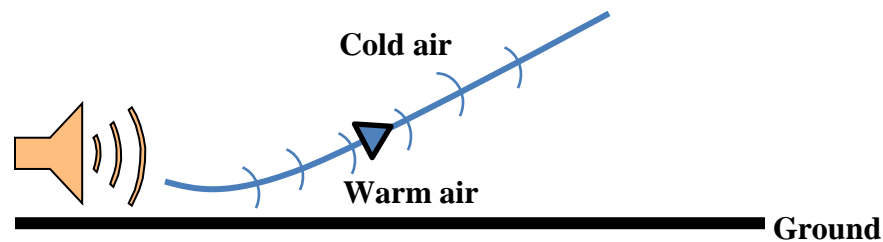

Refraction of sound waves during night:

During night, air around the ground is cold (more dense) and air above the ground is warm (less dense). The sound waves move from a more dense medium to a less dense medium hence they are refracted towards the ground after undergoing through total internal reflection.

This explains why;

- Sound is easily heard during night.
- Radio signals are clear during clear.

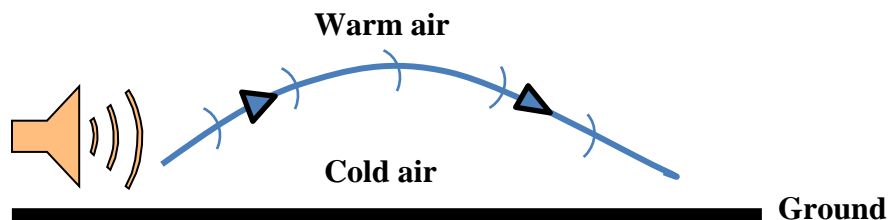

Differences between sound waves and light waves:

Sound waves	Light waves
<ul style="list-style-type: none"> ▪ They are longitudinal waves. ▪ They are mechanical waves so they require a material medium for their travel. ▪ They can't travel through a vacuum. ▪ They have a longer wavelength. ▪ They travel at a low speed i.e. 330ms^{-1} 	<ul style="list-style-type: none"> ▪ They are transverse waves. ▪ They are mechanical waves so they require a material medium for their travel. ▪ They can travel through a vacuum. ▪ They have a short wavelength. ▪ They travel at a high speed i.e. $3 \times 10^8\text{ms}^{-1}$

MUSICAL SOUNDS

These are sounds of regular and uniform vibrations.

Musical sounds are also called musical notes or tones.

Definition:

A musical note is a sound of regular frequency produced by a musical instrument.

A combination of musical notes gives out music.

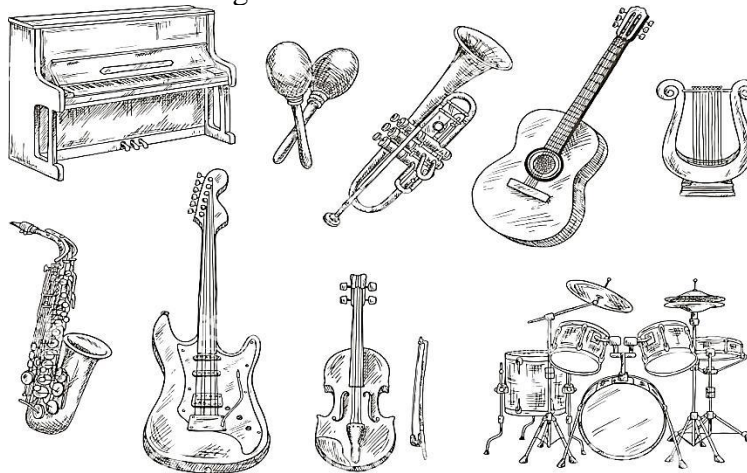
MUSIC AND NOISE:

Music: This is an organized sound produced by regular vibrations.

Noise: This is a disorganized sound produced by irregular vibrations.

Characteristics of musical sounds:

There are properties of music namely; -

- Pitch
- Loudness
- Quality/timbre

Pitch:

This is the loudness or softness of sound.

It depends on the frequency of sound produced. The higher the frequency, the higher the pitch.

Loudness of sound:

This is the amount of sound energy that enters the ear per second.

It depends on the:

- Amplitude i.e. a loud note has higher amplitude and a soft note has a low amplitude.
- Sensitivity of the ear i.e. a more sensitive ear will hear a soft note as being loud.
- Intensity of sound i.e. rate of flow of sound per unit area.

Quality/Timbre:

This is the characteristic which helps the ear to differentiate between sounds of same pitch and loudness.

It depends on the frequency and amplitude of a note therefore, the number of overtones produced by a musical instrument determines the quality of music.

VIBRATING STRINGS

Many musical instruments produce sound by plucking their strings e.g. guitar, violins



Violin



Guitars

FACTORS AFFECTING FREQUENCY OF STRETCHED VIBRATING STRINGS

(a) Length, L:

Frequency is inversely proportional to length of the string. Increasing the length of a string produces a note of low frequency and decreasing the length gives a note of high frequency.

Experiment to show how length affects frequency of sound waves using a sonometer:

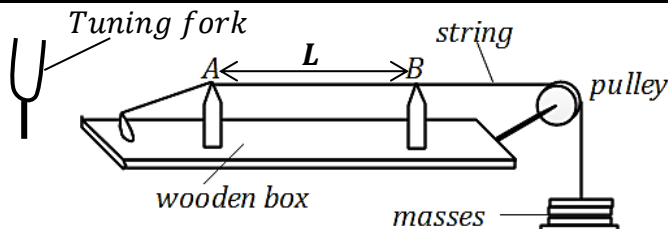

- Known masses are hung at the end of the string passing over the bridges A and B.
- A tuning fork of known frequency, f is sounded.
- Keeping A fixed, B is moved until a note heard by plucking in the middle of the string is same as that from the fork.
- The length between A and B is measured and recorded.

- The experiment is repeated with tuning forks of different frequencies.
- A graph of f against L is plotted and it is a non-straight graph showing that frequency is inversely proportional to length.

$$f \propto \frac{1}{L}, \quad f = K \frac{1}{L}$$

$$fL = K \text{ hence } f_1L_1 = f_2L_2$$

EXAMPLES:

1. A string has length of 0.75m and the first frequency of 200Hz. Find the new frequency if the length is increased to 1m.

$$f_1 = 200\text{Hz} \quad L_1 = 0.75\text{m} \quad f_2 = ? \quad L_2 = 1\text{m}$$

$$f_1L_1 = f_2L_2$$

$$200 \times 0.75 = f_2 \times 1$$

$$f_2 = 150\text{Hz}$$

2. A musical note has frequency of 420Hz and length, L . If the length of the string reduced by a half. Find the new frequency.

$$f_1 = 420\text{Hz} \quad L_1 = L \quad f_2 = ? \quad L_2 = \frac{L}{2}$$

$$f_1L_1 = f_2L_2$$

$$420 \times L = f_2 \times \frac{L}{2}$$

$$f_2 = 420 \times 2$$

$$f_2 = 840\text{Hz}$$

(b) Tension, T:

The higher the tension in the string, the higher the frequency of the note produced. Therefore, increasing tension increases the frequency.

In the above experiment, adding more masses will increase the frequency of note.

Note: This explains why drummers first warm their drums before using them.

(c) Mass per unit length (thickness of string):

Thin strings/wires normally produce notes of high frequency while thick strings/wires normally produce notes of low frequency.

WAVES PRODUCED BY A VIBRATING STRING

When the ends of a string are fixed and it is plucked in the middle, two transverse waves are formed and travel in opposite directions along the string forming a stationary wave.

STATIONARY (STANDING) WAVE:

This is the wave formed when two progressive waves of the same frequency and wavelength travelling in opposite direction meet.

Stationary waves produce nodes and antinodes.

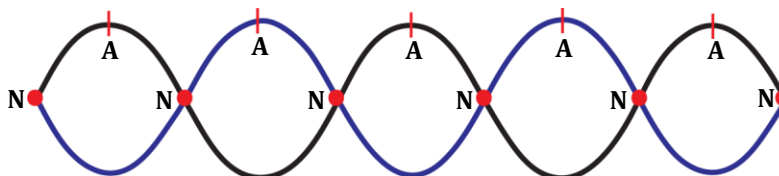

NODE (N): This is a point on a stationary wave where wave particles are at rest.

The amplitude of a wave is zero at this point.

ANTINODE: This is a point on a stationary wave where wave particles have maximum displacement.

The amplitude of a wave at this point is maximum.

NOTE:

The distance between two successive nodes or antinodes is equal to half of wavelength ($\frac{1}{2}\lambda$)

EXAMPLES:

1. The distance between two successive nodes is 12cm. Find the wavelength of the wave.

$$\frac{1}{2}\lambda = 12$$
$$\lambda = 24\text{cm}$$

Conditions necessary for stationary waves to be formed:

- The waves should have the same frequency.
- The waves should have the same speed.
- The waves should have the same wavelength.
- The waves should have the same amplitude.
- The waves should be moving in opposite directions.

IMPORTANT TERMS:

Fundamental note:

This is the lowest audible note produced by a musical instrument.

Fundamental frequency (f_1):

This is the frequency of the fundamental note.

Overtone:

This is the note whose frequency is higher than the fundamental frequency.

- Overtones are used to determine the quality of sound.

Harmonic:

This is a note whose frequency is an integral multiple of the fundamental frequency.

i.e. $f_1, 2f_1, 3f_1, 4f_1 \dots$

Octave:

This is the interval between one note and another note which is half or double its frequency. i.e.

$$f_2 = 2^n f_1 \text{ where } f_1 \text{ is the lower frequency}$$
$$f_2 \text{ is the higher frequency}$$
$$n \text{ is the number of octaves.}$$

Examples:

1. Find the frequency of a note four octaves above a note of frequency 20Hz.

$$f_1 = 20\text{Hz}, f_2 = ?, n = 4$$
$$f_2 = 2^n f_1$$
$$f_2 = 2^4 \times 20$$
$$f_2 = 320\text{Hz}$$

2. Find the frequency of a note 2 octaves below a note of frequency 512Hz.

$$f_2 = 512\text{Hz}, f_1 = ?, n = 2$$

$$f_2 = 2^n f_1$$

$$512 = 2^2 \times f_1$$

$$f_1 = \frac{512}{4}$$

$$f_1 = 128\text{Hz}$$

NOTE:

Consider a string of length, L fixed at both ends.

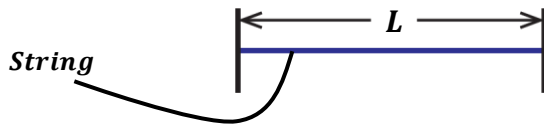

1st harmonic (fundamental note):

This is produced when the string is plucked half-way from one end (middle). The frequency of the note is the fundamental frequency, f_1 .

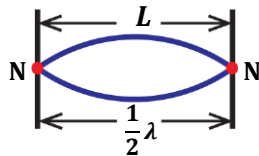

$$L = \frac{1}{2}\lambda, \quad \Rightarrow \lambda = 2L$$

from velocity $V = f_1\lambda$

$$f_1 = \frac{V}{\lambda}$$

$$f_1 = \frac{V}{2L} \dots \dots \dots (i)$$

2nd harmonic (first overtone):

This is produced when the string is plucked quarter-way from one end. The frequency of the note is f_2 .

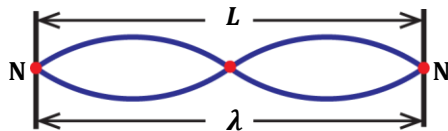

$$L = \lambda, \quad \Rightarrow \lambda = L$$

from velocity $V = f_2\lambda$

$$f_2 = \frac{V}{\lambda}$$

$$f_2 = \frac{V}{L} \dots \dots \dots (ii)$$

Combining equations (i) and (ii)

Making V the subject in equation (i) $V = 2Lf_1 \dots \dots \dots **$

Substitute equation ** into (ii)

$$f_2 = \frac{2Lf_1}{L}$$

$$\boxed{f_2 = 2f_1}$$



3rd harmonic (second overtone):

This is produced if the string is plucked a sixth-way from one end.
The frequency of the note is f_3 .

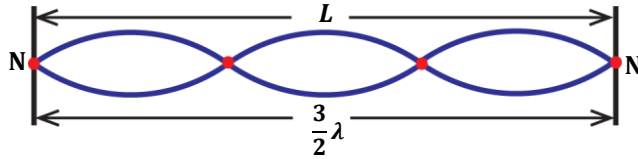

$$L = \frac{3}{2}\lambda, \quad \Rightarrow \lambda = \frac{2L}{3}$$

from velocity $V = f_3\lambda$

$$f_3 = \frac{V}{\lambda}$$

$$f_3 = \frac{V}{\frac{2L}{3}}$$

$$f_3 = \frac{3V}{2L} \dots \dots \dots (iii)$$

Substitute equation ** into (iii): $f_3 = \frac{3 \times 2Lf_1}{2L}$

$$f_3 = 3f_1$$

NOTE:

From the above, the harmonics are $f_1, 2f_1, 3f_1, 4f_1, 5f_1, 6f_1, 7f_1 \dots \dots$
Therefore, a vibrating string produces both odd and even harmonics and overtones.

EXAMPLES:

- The frequency of the third harmonic produced by a vibrating string is 660Hz. Find the length of the string if the speed of sound is 330m/s

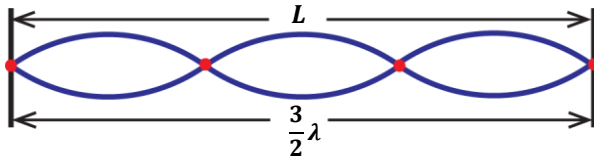

$$f_3 = 660\text{Hz} \quad L = \frac{3}{2}\lambda, \quad \Rightarrow \lambda = \frac{2L}{3}$$

from velocity $V = f_3\lambda$

$$f_3 = \frac{V}{\lambda} \quad \Rightarrow \quad f_3 = \frac{V}{\frac{2L}{3}}$$

$$f_3 = \frac{3V}{2L}$$

$$660 = \frac{3 \times 330}{2L}$$

$$\frac{1320L}{1320} = \frac{990}{1320}$$

$$L = 0.75\text{m}$$

Alternatively:

$$f_3 = 3f_1$$

$$660 = 3f_1$$

$$f_1 = \frac{660}{3}$$

$$f_1 = 220\text{Hz}$$

But $f_1 = \frac{V}{2L}$

$$220 = \frac{330}{2L}$$

$$L = 0.75\text{m}$$



2. Find the frequency of the second harmonic produced by a vibrating string whose fundamental frequency is 300Hz.

$$f_1 = 300\text{Hz}$$

$$f_2 = 2f_1$$

$$f_2 = 2 \times 300$$

$$f_2 = 600\text{Hz}$$

3. The frequency of the second overtone is 300Hz. Find the fundamental frequency.

second overtone = third harmonic, $f_3 = 300\text{Hz}$

$$f_3 = 3f_1$$

$$300 = 3f_1$$

$$f_1 = \frac{300}{3}$$

$$f_1 = 100\text{Hz}$$

WAVES PRODUCED IN PIPES

Pipes used are either closed and open.

Closed pipes:

These are pipes which are closed at one end and open at the other end. The wave formed has a node at closed end and the antinode at open end. The length of the tube is L.

1st harmonic (fundamental note):

This is the first position of resonance. The frequency is the fundamental frequency, f_1 .

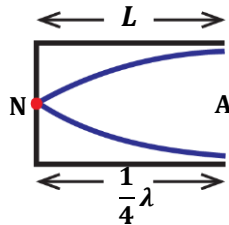

$$L = \frac{1}{4}\lambda, \quad \Rightarrow \lambda = 4L$$

from velocity $V = f_1\lambda$

$$f_1 = \frac{V}{\lambda}$$

$$f_1 = \frac{V}{4L} \dots \dots \dots (i)$$

3rd harmonic (first overtone):

This is the second position of resonance. The frequency of the note is f_3 .

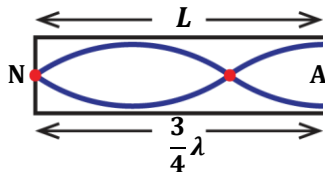

$$L = \frac{3}{4}\lambda, \quad \Rightarrow \lambda = \frac{4L}{3}$$

from velocity $V = f_3\lambda$

$$f_3 = \frac{V}{\lambda}$$

$$f_3 = \frac{V}{\frac{4L}{3}}$$

$$f_3 = \frac{3V}{4L} \dots \dots \dots (ii)$$

Combining equations (i) and (ii)

Making V the subject in equation (i) $V = 4Lf_1 \dots \dots \dots **$

Substitute equation ** into (ii)

$$f_3 = \frac{3(4Lf_1)}{4L}$$

$$\boxed{f_3 = 3f_1}$$

5th harmonic (second overtone):

This is the third position of resonance.

The frequency of the note is f_5 .

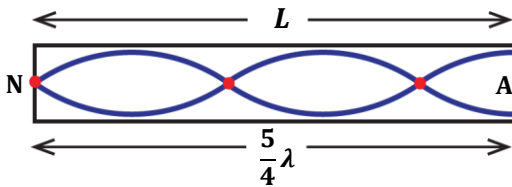

$$L = \frac{5}{4}\lambda, \quad \Rightarrow \lambda = \frac{4L}{5}$$

from velocity $V = f_5\lambda$

$$f_5 = \frac{V}{\lambda}$$

$$f_5 = \frac{V}{\frac{4L}{5}}$$

$$f_5 = \frac{5V}{4L} \dots \dots \dots (iii)$$

Substitute equation ** into (iii):

$$f_5 = \frac{5 \times (4Lf_1)}{4L}$$

$$\boxed{f_5 = 5f_1}$$

NOTE:

Closed pipes only produce odd harmonics i.e. $f_1, 3f_1, 5f_1, 7f_1, 9f_1, 11f_1, \dots$

Open pipes:

Open pipes are open at both ends.

Antinodes are formed at both ends.

1st harmonic (fundamental note):

This is the first position of resonance.

The frequency of the note is the fundamental frequency, f_1 .

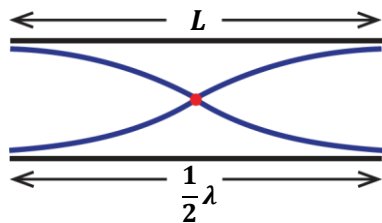

$$L = \frac{1}{2}\lambda, \quad \Rightarrow \lambda = 2L$$

from velocity $V = f_1\lambda$

$$f_1 = \frac{V}{\lambda}$$

$$f_1 = \frac{V}{2L} \dots \dots \dots (i)$$

2nd harmonic (first overtone):

This is the second position of resonance.
The frequency of the note produced is f_2 .

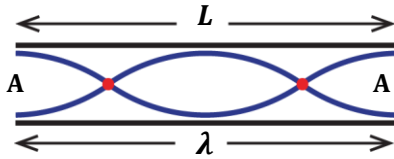

$$L = \lambda, \quad \Rightarrow \lambda = L$$

from velocity $V = f_2 \lambda$

$$f_2 = \frac{V}{\lambda}$$

$$f_2 = \frac{V}{L} \dots \dots \dots (ii)$$

Combining equations (i) and (ii)

Making V the subject in equation (i) $V = 2Lf_1 \dots \dots \dots **$

Substitute equation ** into (ii)

$$f_2 = \frac{2Lf_1}{L}$$

$f_2 = 2f_1$

3rd harmonic (second overtone):

This is the third position of resonance.
The frequency of the note produced is f_2 .

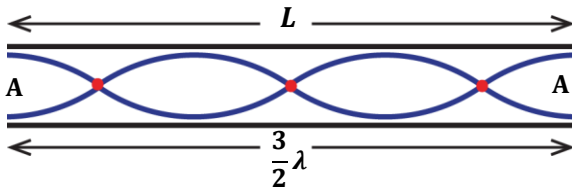

$$L = \frac{3}{2} \lambda, \quad \Rightarrow \lambda = \frac{2L}{3}$$

from velocity $V = f_3 \lambda$

$$f_3 = \frac{V}{\lambda}$$

$$f_3 = \frac{V}{\frac{2L}{3}}$$

$$f_3 = \frac{3V}{2L} \dots \dots \dots (iii)$$

Substitute equation ** into (iii):

$$f_3 = \frac{3 \times 2Lf_1}{2L}$$

$f_3 = 3f_1$

NOTE:

Open pipes produce both odd and even harmonics i.e.

$$f_1, 2f_1, 3f_1, 4f_1, 5f_1, 6f_1, 7f_1 \dots \dots \dots$$

QUESTION: Explain why open pipes are preferred more than closed pipes in making music.

Open pipes are preferred more than closed pipes because they produce high quality sound since they produce both odd and even harmonics.

EXAMPLES:

1. The frequency of the third harmonic in an open pipe is 750Hz. Find the speed of sound if the length of pipe is 0.8m.

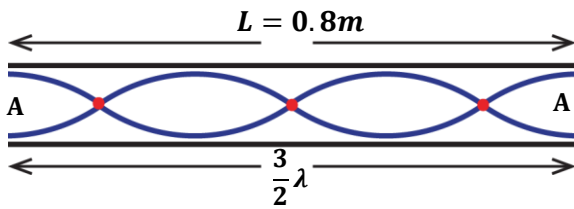

$$L = \frac{3}{2}\lambda, \quad \Rightarrow \lambda = \frac{2L}{3} = \frac{2 \times 0.8}{3} = \frac{8}{15} \text{ m}$$

from velocity $V = f_3 \lambda$

$$V = 750 \times \frac{8}{15}$$

$$V = 400 \text{ ms}^{-1}$$

Alternatively:

$$f_3 = 750 \text{ Hz}, \quad L = 0.8 \text{ m}$$

$$f_3 = 3f_1$$

$$750 = 3f_1$$

$$f_1 = \frac{750}{3}$$

$$f_1 = 250 \text{ Hz}$$

$$\text{But } f_1 = \frac{V}{2L}$$

$$V = 2Lf_1$$

$$V = 2 \times 0.8 \times 250$$

$$V = 400 \text{ ms}^{-1}$$

2. A pipe closed at one end has length 10cm. if the velocity of sound is 340m/s. find

- (i) Fundamental frequency
(ii) Frequency of third harmonic.

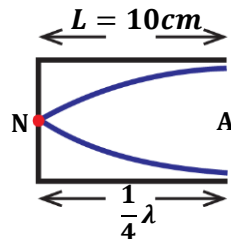

(i)

$$L = \frac{1}{4}\lambda, \quad \Rightarrow \lambda = 4L = 4 \times \frac{10}{100} = 0.4 \text{ m}$$

from velocity $V = f_1 \lambda$

$$f_1 = \frac{V}{\lambda}$$

$$f_1 = \frac{340}{0.4}$$

$$f_1 = 850 \text{ Hz}$$

Alternatively:

$$f_1 = \frac{V}{4L}$$

$$f_1 = \frac{340}{4 \times 0.1}$$

$$f_1 = 850 \text{ Hz}$$

- (ii)

$$f_3 = 3f_1$$

$$f_3 = 3 \times 850$$

$$f_3 = 2550 \text{ Hz}$$

3. A pipe open at both ends has length 40cm. If the velocity of sound is 340m/s. Find the frequency of the;

- (i) Fundamental note.
(ii) First overtone.

$$L = 40 \text{ cm} = \frac{40}{100} = 0.4 \text{ m}, \quad V = 340 \text{ m/s}$$

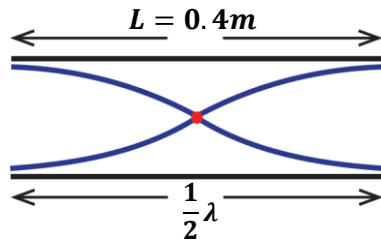

(i)

$$L = \frac{1}{2}\lambda, \quad \Rightarrow \lambda = 2L = 2 \times 0.4$$

$$= 0.8m$$

from velocity $V = f_1\lambda$

$$f_1 = \frac{V}{\lambda}$$

$$f_1 = \frac{340}{0.8}$$

$$f_1 = 425Hz$$

Alternatively:

$$f_1 = \frac{V}{2L}$$

$$f_1 = \frac{340}{2 \times 0.4}$$

$$f_1 = 425Hz$$

(i) **First overtone (2nd harmonic)**

$$f_2 = 2f_1$$

$$f_2 = 2 \times 425$$

$$f_2 = 850Hz$$

4. The frequency of third harmonic in an open pipe is 660Hz, if the speed of sound in air is 330m/s. Find;

- (i) the length of the air column
- (ii) the fundamental frequency

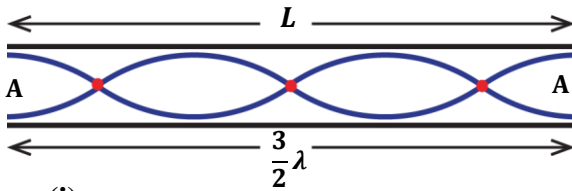

(i)

$$f_3 = 660Hz \quad V = 330m/s$$

from velocity $V = f_3\lambda$

$$\lambda = \frac{V}{f_3}$$

$$\lambda = \frac{330}{660}$$

$$\lambda = 0.5m$$

But $L = \frac{3}{2}\lambda$

$$L = \frac{3}{2} \times 0.5$$

$$L = 0.75m$$

(ii)

$$f_3 = 3f_1$$

$$f_1 = \frac{f_3}{3}$$

$$f_1 = \frac{660}{3}$$

$$f_1 = 220Hz$$

5. A third harmonic (first overtone) of a closed pipe occurs when the length of the air column is 30cm, if the speed of sound in air is 330m/s. Find the;

- (i) frequency of the sound wave
(ii) fundamental frequency

$$L = 30\text{cm} = \frac{30}{100} = 0.3\text{m}, \quad V = 330\text{m/s}$$

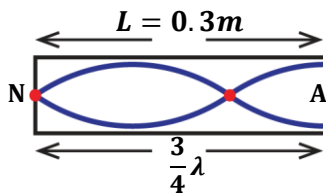

(i)

$$L = \frac{3}{4}\lambda, \quad \Rightarrow \lambda = \frac{4L}{3} = \frac{4 \times 0.3}{3}$$

$$\lambda = 0.4\text{m}$$

from velocity $V = f_3\lambda$

$$f_3 = \frac{V}{\lambda}$$

$$f_3 = \frac{330}{0.4}$$

$$f_3 = 825\text{Hz}$$

(ii) Fundamental frequency

$$f_3 = 3f_1$$

$$f_1 = \frac{f_3}{3}$$

$$f_1 = \frac{825}{3}$$

$$f_1 = 275\text{Hz}$$

6. The frequency of the 4th overtone in an open pipe is 900Hz when the length of the air column is 0.4m. Find the

- (i) Frequency of the fundamental note
(ii) Speed of sound in air.

4th overtone = fifth harmonic

(i) $f_5 = 900\text{Hz}$ $L = 0.4\text{m}$

$$f_5 = 5f_1$$

$$f_1 = \frac{f_5}{5}$$

$$f_1 = \frac{900}{5}$$

$$f_1 = 180\text{Hz}$$

(ii)

$$f_1 = \frac{V}{2L}$$

$$V = 2Lf_1$$

$$V = 2 \times 0.4 \times 180$$

$$V = 144\text{ms}^{-1}$$

RESONANCE

This occurs when a body is set into vibrations at its own natural frequency by another nearby body vibrating at the same frequency.

The resonating body will then vibrate strongly with a greater amplitude.

Examples of resonance in daily life.

- Shaking of window glasses as a heavy vehicle passes by.
- Swinging of legs in a swing so as to swing higher.
- Breaking of wine glass by an opera singer's sound.
- A working generator makes dust to move up and down
- Tuning a radio changes the frequency of the radio waves until it is exactly same as frequency of the waves at transmitting station.

NOTE:

Resonance may lead to collapse of tall buildings, bridges when they resonate with strong winds or earthquakes.

Experiment to demonstrate resonance using coupled pendulum and tubes:

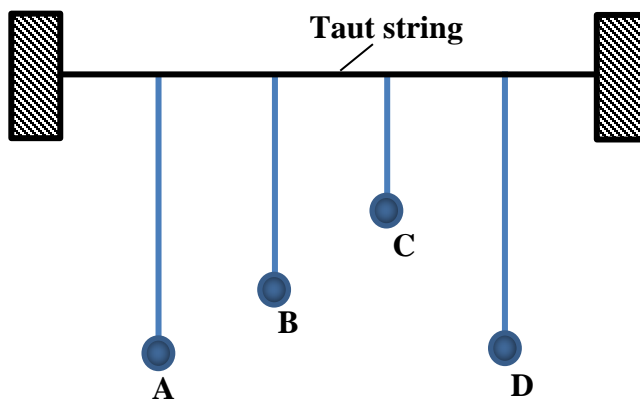

- Hang four pendulum bobs on the same taut string such that pendulum, A has a variable length and other pendulums B, C and D have different fixed lengths.
- Set pendulum, A to the same length as D and make it to swing. It is observed that pendulum, D swings with a larger amplitude but pendulums B and C swing with smaller amplitudes.
- Set pendulum, A to the same length as B and make it swing. It is observed that pendulum, B swings with noticeable amplitude but pendulums C and D just jiggle without a noticeable amplitude.

Experiment to demonstrate resonance using a closed air tube:

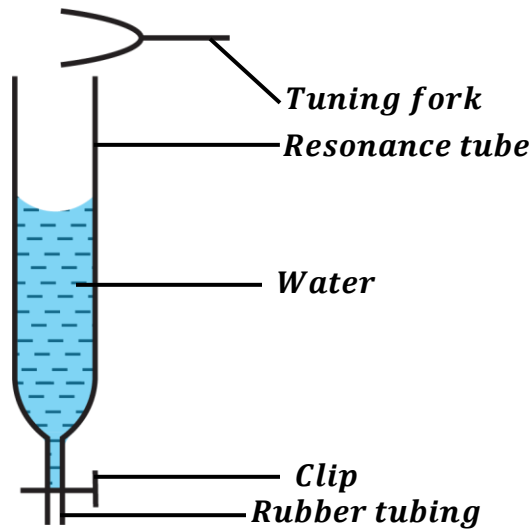

- A resonance tube is almost filled with water.
- A tuning fork is sounded near and above the mouth of the tube.
- Water level is allowed to fall gradually by means of a clip.
- It is observed that at some level of water, the sound suddenly becomes louder. Resonance is said to have occurred.

EXPERIMENT TO DETERMINE SPEED OF SOUND IN AIR BY RESONANCE TUBE

- A tuning fork of known frequency, f is held over the mouth of a resonance tube and then sounded.
- The tube is slowly raised until a first loud sound is heard. This is the first position of resonance.
- The length, L_1 of the air column is measured.

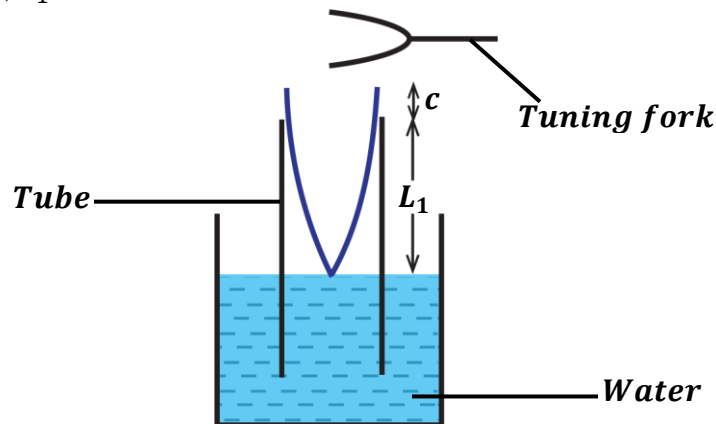

$$L_1 + c = \frac{1}{4}\lambda \dots \dots \dots (i)$$

where c is the end correction of the tube.

- The tube is again raised until a second loud sound is heard. This is the second position of resonance.
- The length, L_2 of the air column is measured.

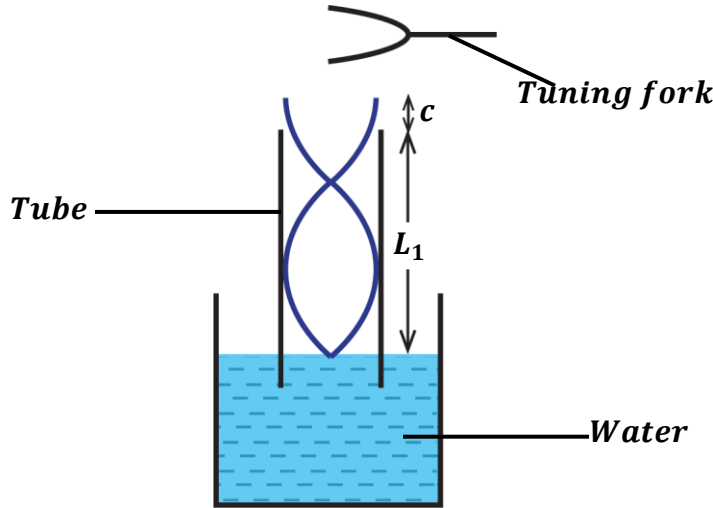

$$L_2 + c = \frac{3}{4}\lambda \dots\dots\dots (ii)$$

subtracting equation (i) from (ii)

$$\left[L_2 + c = \frac{3}{4}\lambda \right] - \left[L_1 + c = \frac{1}{4}\lambda \right]$$

$$L_2 - L_1 = \frac{3}{4}\lambda - \frac{1}{4}\lambda$$

$$L_2 - L_1 = \frac{1}{2}\lambda$$

therefore, $\lambda = 2(L_2 - L_1)$

But $V = f\lambda$

$$V = 2f(L_2 - L_1)$$

- Hence velocity can be calculated from $V = 2f(L_2 - L_1)$.

EXAMPLES:

1. A tube is partially immersed in water and a tuning fork of frequency 425Hz is sounded above it. If the tube is gradually raised, find the length of the tube when first resonance occurs. (velocity of sound is 340m/s and neglect end correction)

for first resonance, $L_1 + c = \frac{1}{4}\lambda$

But $V = f\lambda$
 $340 = 425 \times \lambda$
 $\lambda = \frac{340}{425} = 0.8m$
 $\lambda = 0.8m$

$$L_1 + c = \frac{1}{4}\lambda$$

$$L_1 = \frac{1}{4}\lambda$$

$$L_1 = \frac{1}{4} \times 0.8$$

$$L_1 = 0.2m$$

2. A tube closed at one end resonates first at length 28.5cm and again at 88.5cm when a tuning fork of frequency 285Hz is held near the open end. Find the velocity of sound.

$$f = 285\text{Hz} \quad L_1 = 28.5\text{cm} = \frac{28.5}{100} = 0.285\text{m} \quad L_2 = 88.5\text{cm} = \frac{88.5}{100} = 0.885\text{m}$$

$$V = 2f(L_2 - L_1)$$

$$V = 2 \times 275 \times (0.885 - 0.285)$$

$$V = 330\text{ms}^{-1}$$

3. A tuning fork produces resonance in a tube at a length of 15.0cm and also at length 40.0cm. Find the frequency of the tuning fork if the speed of sound is 330m/s.

$$L_1 = 15\text{cm} = \frac{15}{100} = 0.15\text{m} \quad L_2 = 40\text{cm} = \frac{40}{100} = 0.4\text{m} \quad V = 330\text{m/s}$$

$$V = 2f(L_2 - L_1)$$

$$330 = 2 \times f \times (0.4 - 0.15)$$

$$330 = 0.5f$$

$$f = 600\text{Hz}$$

4. A tuning fork of frequency 256Hz was used to produce resonance at a length 32.5cm and also at length 95.0cm. Calculate the speed of sound in air.

$$f = 256\text{Hz} \quad L_1 = 32.5\text{cm} = \frac{32.5}{100} = 0.325\text{m} \quad L_2 = 95\text{cm} = \frac{95}{100} = 0.95\text{m}$$

$$V = 2f(L_2 - L_1)$$

$$V = 2 \times 256 \times (0.95 - 0.325)$$

$$V = 320\text{ms}^{-1}$$

5. In an experiment the velocity of sound in air using a resonance tube, the following results were obtained:

Length of 1st resonance = 16.1cm

Length of 2nd resonance = 51.1cm

Frequency of tuning fork = 480 Hz

Calculate:

(i) Wavelength of sound

$$L_1 = \frac{16.1}{100} = 0.161\text{m}$$

$$L_2 = \frac{51.1}{100} = 0.511\text{m}$$

$$\lambda = 2(L_2 - L_1)$$

$$\lambda = 2(0.511 - 0.161)$$

$$\lambda = 0.7\text{m}$$

(ii) Speed of sound

$$V = 2f(L_2 - L_1)$$

$$v = 2 \times 480 \times (0.511 - 0.161)$$

$$V = 2 \times 480 \times 0.35$$

$$V = 336\text{ms}^{-1}$$

(iii) End correction of tube

$$L_1 + c = \frac{1}{4}\lambda$$

$$0.161 + c = \frac{1}{4} \times 0.7$$

$$c = 0.175 - 0.161$$

$$c = 0.014\text{m}$$

COMMUNICATION BETWEEN EARTH AND MOON

Moon does not have an atmosphere so there is a vacuum (space without air) around it. So, communication is possible between earth and moon by use of electromagnetic waves called radio waves.

QUESTION: Describe how communication is possible between moon and earth yet the moon has no atmosphere.

- **Radio waves from a transmitter on earth are directed towards the moon. They are able to travel through vacuum around the moon since they are electromagnetic waves.**
- **On reaching the surface of the moon, they are reflected back to the earth's receiver.**
- **Through this process communication is possible.**

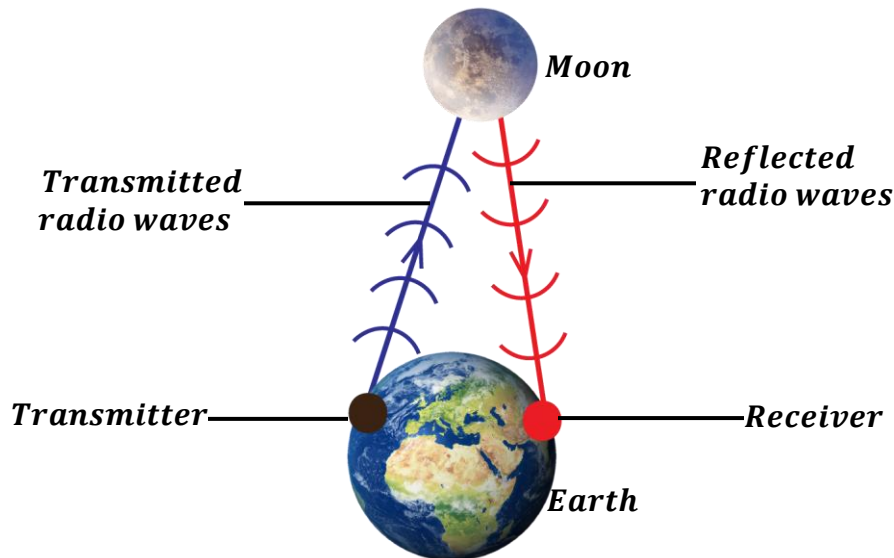

QUESTION: Describe how communication in radios and televisions.

- **Radio stations have transmitters which convert electrical signals into radio waves and send them over a wide area.**
- **On reaching the radios, the antennas (aerials) on radios convert the radio waves back to electrical signals which can be heard by a person**

EXERCISE:

1. A stretched wire adjusted to a length of 48cm produces the same note as a tuning fork whose frequency is 256Hz. If the wire is adjusted to 32cm, what frequency of the tuning fork would be in tune with the wire?
Ans: (384Hz)
2. The frequency of a vibrating wire is 280Hz, when its length is 75cm. Find its frequency when the length is reduced to 50cm
Ans: (420Hz)
3. The frequency of the third harmonic in an open pipe is 590Hz. Find the length of the air column if the speed of sound in air is 330ms^{-1}
Ans: (0.84m)
4. The length of air column in an open pipe is 1.6m. Find the frequency of the third harmonic if the speed of sound in air is 320ms^{-1}
Ans: (300Hz)
5. A pipe closed at one end has a length of 10cm. If the velocity of sound in air of the pipe is 340ms^{-1} , calculate the fundamental frequency and the frequency of the first overtone
Ans: (850Hz, 2550Hz)
6. The frequency of the second harmonic produced in a vibrating string is 600Hz. Find the length of the string given that the speed of sound is 320ms^{-1} .
Ans: (0.55m)
7. The frequency of the fourth overtone produced by a vibrating string of length 25cm given that speed of sound in air is 320ms^{-1} .
Ans: (3200Hz)
8. The length of air column in a closed pipe is 150cm. Find the frequency of the third harmonic if the speed of sound in air is 330ms^{-1}
Ans: (165Hz)
9. The frequency of the third overtone in an open pipe is 750Hz. Find the length of the air column if the speed of sound in air is 300ms^{-1}
Ans: (0.8m)

EXAMINATION QUESTIONS:

1. a) Define the following terms;
 - i) Wavelength
 - ii) Reverberation
 - iii) Stationary waves
- b) i) What is meant by resonance
- ii) State three examples and one hazard caused by resonance
- c) Describe an experiment to determine the velocity of sound in air by resonance tube method
- d) Calculate the frequency of vibration of the fundamental note and the second overtone in an open tube of 25cm long if the velocity of sound is 330ms^{-1}

Ans: 660Hz, 1980Hz.

- e) Given the factors which affect the frequency of vibrations of a stretched string
2. a) What do you understand by the following terms;
 - i) Anti-node
 - ii) Resonance
- b) State the factors which affect the frequency of wave produced by a vibrating string
- c) A sound wave of frequency 300Hz is produced 160m away from a high wall. Calculate
 - i) The wavelength of the sound wave.
 - ii) The time taken for the sound wave to travel to the wall and back to the source.

Ans: i) 1.1m ii) 0.97s

- d) A boy standing some distance from a cliff claps his hands and hears an echo after 5 seconds
 - i) What is distance between the boy and the cliff?
 - ii) How long would it take the boy to hear the echo if there was a wind blowing towards the cliff at a speed of 20ms^{-1}

Ans: i) 825m ii) 4.71s

3. a) What is a wave
- b) As regards to a wave, what is meant by the following
 - i) Frequency
 - ii) Wavelength
- c) State four properties of waves
- d) Describe how a resonance tube may be used to determine the velocity of sound in air
- e) A boy stands between two parallel cliffs but nearer to one of them. When he claps hard once he hears the first echo after 1 second and a second echo 1 second after the first. If the distance between the cliffs is 510m, find the speed of sound.

Ans: 340ms^{-1}

4. a) Define the following terms as applied to waves
 - i) Amplitude
 - ii) Frequency
- b) i) What is meant by interference of waves
- ii) Using a labeled diagram show how circular waves are reflected from a straight barrier
- c) Use a labeled diagram to show the bands of electromagnetic waves.

5. a) i) Define an echo.
 ii) State the conditions required for a stationary wave to be formed
 b) List the factors on which the frequency of a wave in a vibrating string depends
 c) Describe an experiment to demonstrate resonance in a closed pipe
 d) A child stands between two cliffs and makes a loud sound. If he hears the first echo after 1.5 seconds and the second echo after 2.0 seconds, find the distance between the two cliffs, if the speed of sound in air is 330ms^{-1} .

Ans: 577.5m

6. The diagram below is of a cross section of a ripple tank in which A is a straight dipper and B a barrier with two gaps.

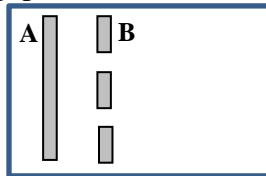

- a) Sketch a diagram showing waves produced when A vibrates perpendicular to the water surface
 b) What will happen when?
 i) The gaps are made narrower
 ii) The separation of the gaps is increased
 iii) The frequency of the vibrator A is decreased
 c) If A vibrates with a frequency of 20Hz and is 25cm from B, find
 i) The speed of the wave if the wave front takes 5s from A to B
 ii) The wavelength of the waves

Ans: i) 0.05ms^{-1} ii) $2.5 \times 10^{-3}\text{m}$

- d) State differences between water waves and light waves

7. a) Give three similarities and three differences between sound waves and radio waves
 b) i) Describe how the speed of sound in air can be determined by an echo method
 ii) A student standing between two vertical cliffs produces sound by clapping his hands together. He hears the first echo after 3seconds and a second echo after 5seconds. Calculate the distance between the two cliffs

Ans: ii) 1320m

- c) A radio station broadcasts at 100m band
 i) What is meant by this statement?
 ii) Calculate the frequency of the broadcast.

Ans: ii) $3.0 \times 10^6\text{Hz}$.

8. a) State two differences between sound and light waves
 b) i) Describe a simple experiment to determine the velocity of sound in air
 ii) Explain why the speed of sound is higher in solids than in air
 c) Two people X and Y stand in a line at a distance of 330m and 660m respectively from a high wall. Find the time interval taken for X to hear the first and sounds when Y makes a loud sound if the speed of sound in air is 330ms^{-1}

Ans: 2.0s

- d) i) What is meant by a stationary wave
 ii) Give any two conditions
 iii) Name one musical instrument which produces stationary waves
9. a) With aid of a diagram explain the terms amplitude and wavelength as applied to wave motion
 b) i) Derive an equation relating velocity, V frequency, f and wavelength, λ of a wave
 ii) A radio wave is transmitted at a frequency of 150Hz. Calculate its wavelength

Ans: $2.0 \times 10^6 \text{ Hz}$.

- c) i) List four properties of electromagnetic waves
 ii) A long open tube is partially immersed in water and a tuning fork of frequency 425Hz is sounded and held above it. If the tube is gradually raised, find the length of air column when resonance first occurs. Neglect end correction and take speed of sound in air = 340 ms^{-1}
- Ans: ii) 0.2m**
10. a) Explain the difference between transverse and longitudinal waves. Give one example of each
 b) The diagram in the figure below represents a plane view of horizontal ripple tanks set up to study characteristics of water waves.

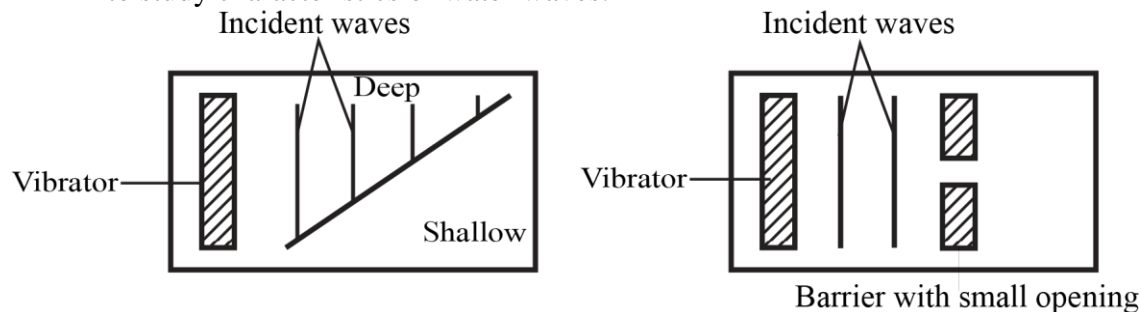

The vibrators were set up to produce waves

- (i) Draw diagrams to show wave patterns in A and B.
 (ii) Explain what happens to plane waves in each case.
11. a) i) Describe how the speed of waves in a ripple tank can be decreased
 ii) Explain the effect of decreasing the speed of the wave in (a) (i) on frequency
 b) With the aid of sketch diagrams, explain the effect of size of a gap on diffraction of waves
 c) i) Give two reasons why sound is louder at night than during the day
 ii) An echo-sounding equipment on a ship receives sound pulses reflected from the sea bed 0.02 seconds after they were sent out from it. If the speed of sound in water is 1500 ms^{-1} , calculate the depth of water under the ship.

Ans: ii) 15m

- d) Identify two differences between water and sound waves
12. a) Define the following terms as applied to waves;
 i) Amplitude
 ii) Frequency
 b) i) What is meant by interference of waves
 ii) Using a labeled diagram show how circular water waves are reflected from a straight barrier

- c) i) Use a labeled diagram to show the bands of an electromagnetic spectrum
 ii) Calculate the frequency of a radio wave of wavelength 2m

Ans: ii) $1.5 \times 10^3 \text{ Hz}$

- d) i) State any three effects of electromagnetic radiation on matter
 ii) State two properties that electromagnetic waves have in common
13. a) i) Explain each of the following observations;
 ii) Sound from a distant source is louder at night than during day time
 b) Describe an experiment to show interference of sound waves
 c) A man stands between two cliffs and makes a loud sound. He hears the first echo after 1 second and the second echo after a further 1 second. Find the distance between the cliffs

Ans: 495m

- d) Straight water waves travel from deep to shallow water as shown below

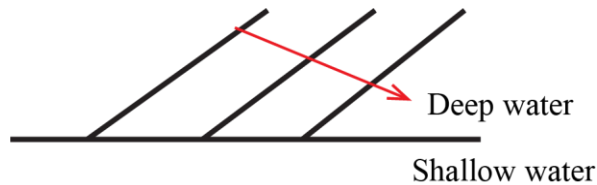

Copy and complete the wave front pattern in shallow water

14. a) State differences between sound and light waves
 b) i) Explain how stationary waves are formed
 ii) State three main characteristics of stationary waves
 c) i) Define the terms frequency and wavelength as applied to sound
 ii) Describe an experiment to demonstrate resonance in sound
 d) The velocity and frequency of sound in air at a certain time were 320ms^{-1} and 200Hz respectively. At a later time, the air temperature changed and the velocity of sound in air was found to be 340ms^{-1} . Determine the change in wavelength of sound.

Ans: 0.1m

15. a) List three differences between sound waves and radio waves
 b) Figure below shows waves propagating towards a concave reflector

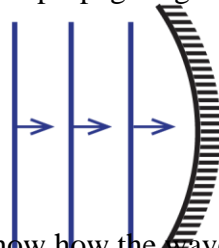

- i) Draw a diagram to show how the waves are reflected
 ii) If the velocity of the waves is 320ms^{-1} and the distance between two successive crests is 10cm, find the period of the waves

Ans: $3.125 \times 10^{-4} \text{ s}$

- c) Describe a simple echo method of determining the speed of sound in air.
16. a) What is meant by sound
 b) Describe an experiment to show that sound waves require a material medium for transmission
 c) Explain briefly the following;
 i) A dog is more able than a human being to detect the presence of a thief tiptoeing at

night

- ii) An approaching train can easily be detected by human ears placed close to the rails
 d) A sound frequency 250Hz is produced 120m away from a high wall. If the speed of sound in air is 330ms^{-1} , calculate the

- i) Wavelength ii) Time it takes the sound wave to travel to and from the wall.

Ans: i) 1.32m ii) 0.73s

17. a) i) State two factors which affect the frequency of the note produced by the string
 ii) Why does the quality (timbre) of the sound produced by a violin differ from that produced by a piano?
 b) Describe an experiment to show that sound waves do not travel through a vacuum
 c) A pipe is closed at one end has a length of 10cm. if the velocity of sound in the air of the pipe is 340ms^{-1} . Calculate
 i) The fundamental frequency
 ii) The first overtone

Ans: i) 850Hz ii) 2550Hz

- d) State four differences between sound waves and light waves
 18. a) i) Describe a simple experiment to determine the velocity of sound in air
 ii) What factors would affect the value of velocity of sound obtained from the experiment in (i) above
 b) Explain why a musical note played on a piano sounds different from that played on a guitar
 c) i) Calculate the wavelength of sound waves of frequency 3.3kHz and speed 330ms^{-1}
 ii) State four differences between sound and radio waves

Ans: i) 0.1m

19. a) List three differences and three similarities between sound waves and light waves
 b) The diagram below shows circular waves propagating towards a plane reflector

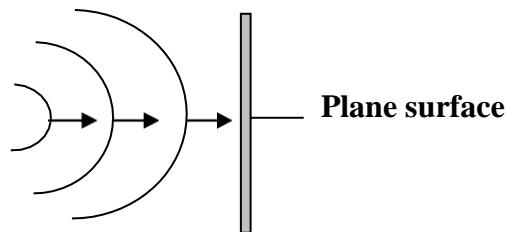

- i) Draw a diagram to show how the waves will be reflected
 ii) Calculate the frequency of the waves if their velocity and wavelength are 5.0ms^{-1} and 0.5m respectively

Ans: ii) 10Hz

- c) A man stands midway between two cliffs and makes a loud sound. He hears the first echo after 3 seconds. Find the distance between the cliffs, if the velocity of sound in air is 330ms^{-1} .

Ans: 990m

20. a) Define each of the following terms as applied to wave motion
 i) Wave front
 ii) Wavelength

- b) The wavelength of radio wave is 10m. Calculate
- The frequency
 - The period of the wave

Ans: i) $3.0 \times 10^7 \text{ Hz}$ ii) $3.33 \times 10^{-8} \text{ s}$

- c) Why does sound travel faster in solids than in gases

- d) i) What is meant by the term resonance

- ii) The frequency of the third harmonic in a closed pipe is 280Hz. Find the length of the air column in the pipe.

Ans: ii) 0.75m

ELECTROSTATICS

Electrostatics is the study of electric charges at rest.

These charges include;

- Positive charges (+)
- Negative charges (-)

STRUCTURE OF AN ATOM

An atom is the smallest particle of an element that can take part in a chemical reaction.

An atom consists of three particles namely;

- Electrons
- Neutrons
- Protons

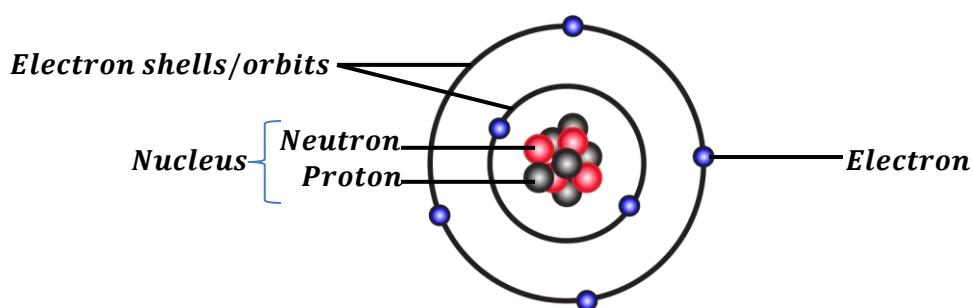

Properties and location of the particles of an atom:

Particle	Location	Charge
Proton	In the nucleus of an atom	Positive charge (+)
Electron	It orbits outside the nucleus of an atom	Negative charge (-)
Neutron	In the nucleus of an atom	No charge (neutral)

Note:

In an atom, the number of protons in the nucleus is equal to the number of electrons outside the nucleus. Therefore, an atom is said to be **neutral** (has no charge).

Since the nucleus has only protons and neutrons, then it is positively charged.

NB: Any material that loses electrons becomes positively charged and any material that gains electrons becomes negatively charged.

CONDUCTORS AND INSULATORS

Conductors:

A **conductor** is a material with free electrons and can allow heat and electricity to pass through it easily.

The electrons in a conductor are free to move because they are loosely held outside the nucleus of an atom.

Examples of conductors include; all metals, carbon in form of graphite, acids, bases and salt solutions.

Insulators:

An **insulator** is a material without free electrons and cannot allow heat and electricity to pass through it easily.

The electrons in an insulator are not free to move because they are tightly or strongly held outside the nucleus of an atom.

Examples of insulators include; rubber, dry wood, glass plastic, ebonite, fur, polythene, etc.

Differences between conductors and insulators:

Conductors	Insulators
<ul style="list-style-type: none"> • Electrons are free to move. • Electrons are loosely held outside the nucleus of an atom. • They are good conductors of heat and electricity. 	<ul style="list-style-type: none"> • Electrons are not free to move. • Electrons are tightly held outside the nucleus of an atom. • They are poor conductors of heat and electricity.

LAW OF ELECTROSTATICS

It states that like charges repel while unlike charges attract each other.

ELECTRIFICATION (CHARGING MATERIALS)

This is the process of producing electric charges.

There various methods of charging materials and they include:

- Charging by friction/rubbing
- Charging by contact/conduction
- Charging by induction (electrostatic induction)

Charging by friction/rubbing:

This is the best method for charging insulators

- Two insulators are rubbed together and electrons are transferred from one insulator to another.
- The insulator that gains electrons becomes negatively charged and the insulator that loses electrons becomes positively charged.
- Therefore, the two insulators acquire equal but opposite charges.

The table below shows insulators gaining and losing electrons when rubbed:

Loses electrons	Gains electrons
Glass	Ebonite
Fur	Silk
Cellulose	Polythene

Example:

- ❖ When silk and glass are rubbed against each other, the glass atoms lose electrons hence acquiring a positive charge and the silk atoms gain electrons hence acquiring a negative charge.

The resulting electric force can attract small pieces of paper.

Question 1: Describe how fur and silk can be charged by friction.

- *Fur and silk are rubbed against each other.*
- *Fur atoms lose electrons and acquire a positive charge.*
- *Silk atoms gain electrons and acquire a negative charge.*
- *Therefore, fur and silk acquire equal but opposite charges.*

Question 2: Describe how ebonite and glass can be electrified.

- *Glass and ebonite are rubbed against each other.*
- *Glass atoms lose electrons and acquire a positive charge.*
- *Ebonite atoms gain electrons and acquire a negative charge.*
- *Therefore, glass and ebonite acquire equal but opposite charges.*

Charging by contact/conduction:

This method is only good for conductors. The charges are shared among the conductors.

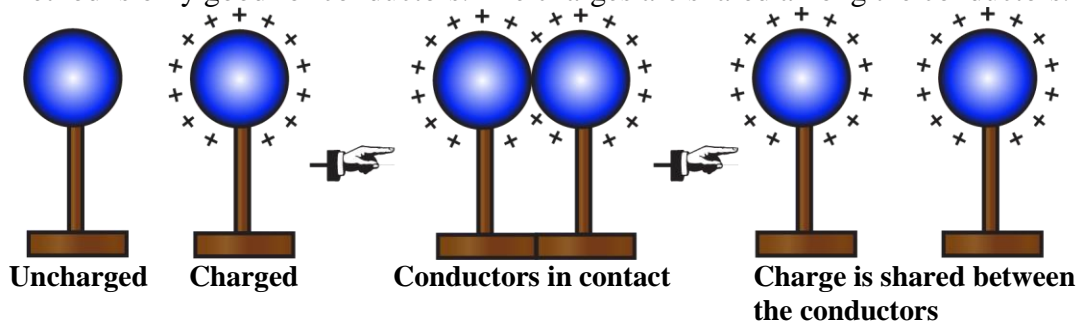

- Bring the uncharged conductor in contact with a charged conductor.
- Separate the two conductors after short period of time.
- The uncharged conductor will acquire a similar equal charge to that of a charged conductor.

Charging by electrostatic induction:

This is the method of charging a conductor without touching it with a charged body.

It involves bringing a charged body near the body to be charged.

The uncharged body acquire a charge opposite to that of a charging body.

Charging a conductor positively by induction:

- Bring a negatively charged body near one side of a conductor placed on an insulated stand.
- Positive charges are induced on the side near the charged body and negative charges are repelled to the other side.

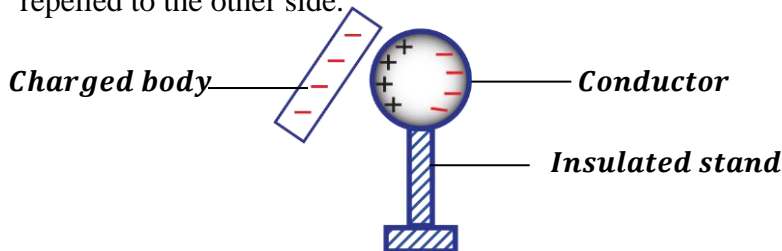

- With the charged body still in position, the other side of the conductor is earthed by connecting it with an earth wire to the ground. Electrons flow to the ground through the earth wire.

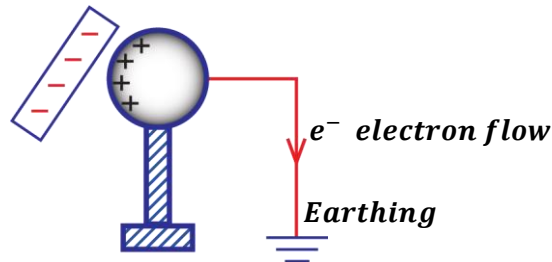

- With the charged body still in position, the earthing is removed and then the charged body is also removed.
- Positive charges distribute themselves all over the conductor and the conductor is left with a net positive charge.



Charging a conductor negatively by induction:

- Bring a positively charged body near one side of a conductor placed on an insulated stand.
- Negative charges are induced on the side near the charged body and positive charges are repelled to the other side.

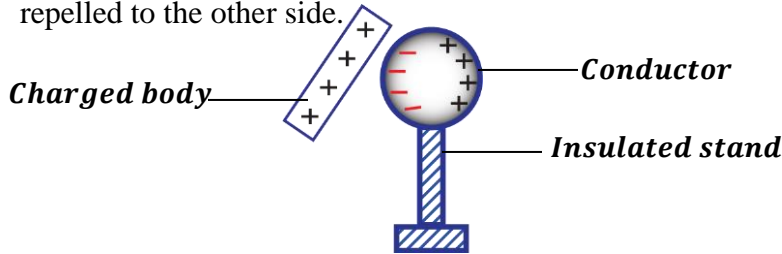

- With the charged body still in position, the other side of the conductor is earthed by connecting it with an earth wire to the ground. Electrons flow from the ground and neutralize the positive charges on the conductor.

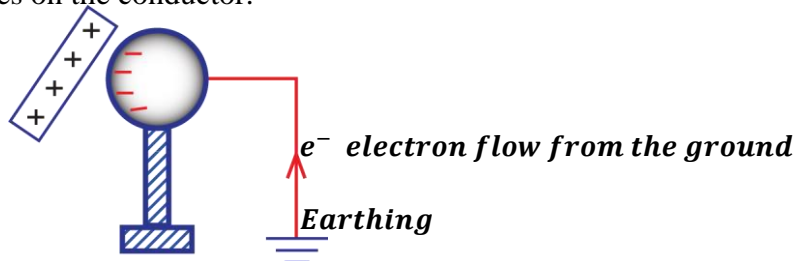

- With the charged body still in position, the earthing is removed and then the charged body is also removed.
- Negative charges distribute themselves all over the conductor and the conductor is left with a net negative charge.



NOTE:

Earthing a conductor may also be done by touching it with the fingers since human bodies are good conductors of electricity.

Charging two conductors simultaneously with an opposite charge by induction:

- Place two conductors A and B in contact and on an insulated stand.
- Bring a negatively charged body near conductor A.
- Positive charges are induced on conductor A and negative charges repelled to conductor B.

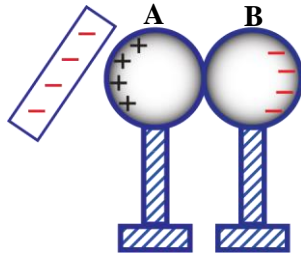

- With the charged body still in position, the conductors are separated. On removing the charged body, the charges distribute all over the conductors.
- Conductor A acquires a net positive charge and conductor B acquires a net negative charge.

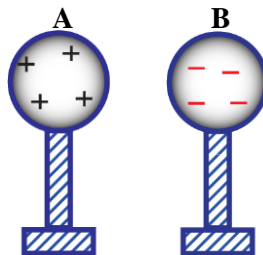
Charging two conductors simultaneously with the same charge by induction:

- Place two conductors A and B in contact and on an insulated stand.
- Bring a negatively charged body near conductor A.
- Positive charges are induced on conductor A and negative charges repelled to conductor B.

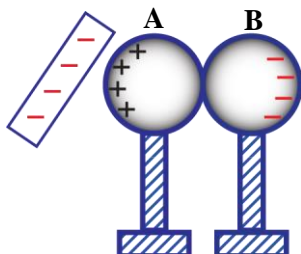

- With the charged body still in position, conductor B is earthed by connecting it with an earth wire to the ground. Electrons flow to the ground.

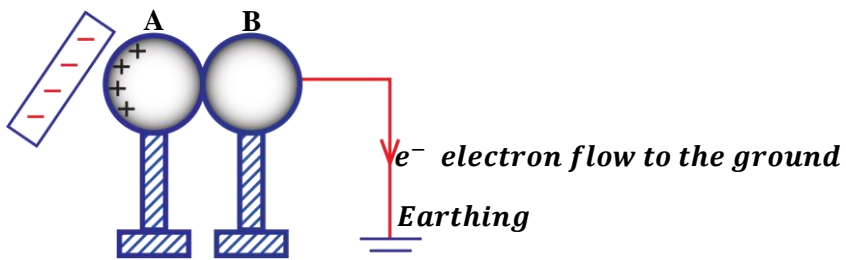

- With the charged body still in position, the earthing is removed and then the charged body is also removed.
- Positive charges distribute themselves all over the two conductors and the conductors are left with a net positive charge.

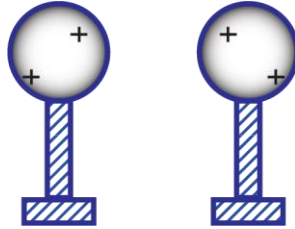

GOLD LEAF ELECTROSCOPE (GLE)

A gold leaf electroscope is an instrument used to detect the presence of charge and differentiate between the charges.

Structure of a gold leaf electroscope:

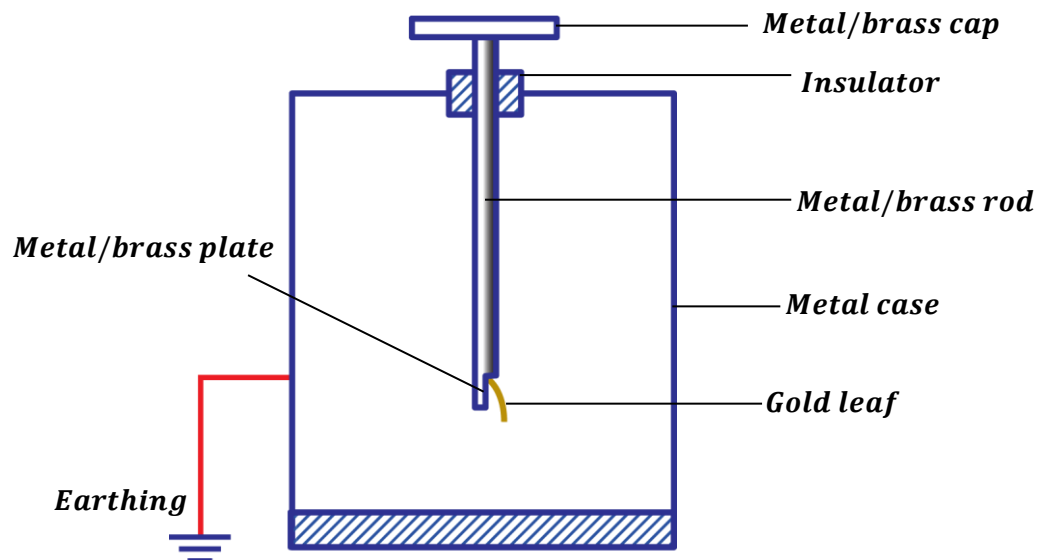

It consists of a metal cap and metal plate joined together by a metal rod.
 It consists of a metal case with glass windows to protect it from draught.
 The metal case is always earthed to keep it at zero potential.
 The electroscope is insulated so that there is no inflow and outflow of charges

Mode of action of a gold leaf electroscope:

- When a charged body is brought near the cap of the electroscope, the cap will acquire an opposite charge to that on the charged body by induction.
- The charge on the body will repel all charges similar to it down to the metal rod, to the plate and the leaf.
- Due to presence of like or similar charges on the plate and gold leaf, the leaf diverges as it is repelled by the plate.
- Therefore, leaf divergence means that the body brought near with the cap carries a charge.

Charging a Gold Leaf Electroscope positively by induction:

- Bring a negatively charged rod near the cap of an uncharged gold leaf electroscope.
- Positive charges are induced on the cap and negative charges are repelled down to the plate and the gold leaf. The leaf diverges due to presence of like charges at the plate and the leaf.

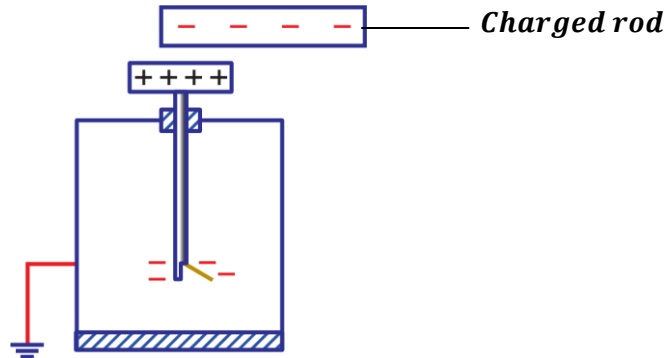

- With the charged rod still in position, the gold leaf electroscope is earthed by connecting it with an earth wire to the ground. Electrons flow from the plate and the leaf to the ground through the earth wire. This causes the leaf to collapse (decrease in divergence of the leaf)

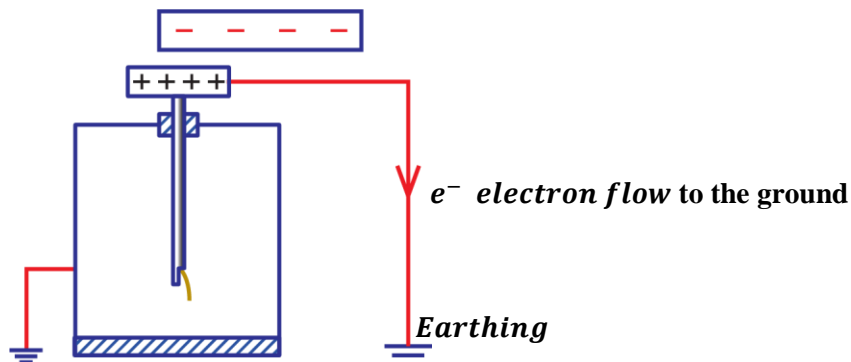

- With the charged rod still in position, the earthing is removed and then the charged rod is also removed.
- Positive charges distribute themselves all over the metal cap, plate and gold leaf. The leaf diverges again due to presence of like charges at the plate and the leaf.

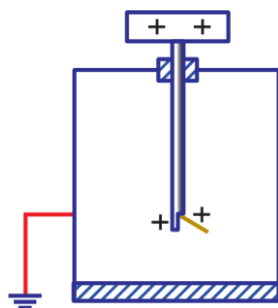

Charging a Gold Leaf Electroscope negatively by induction:

- Bring a positively charged rod near the cap of an uncharged gold leaf electroscope.
- Negative charges are induced on the cap and positive charges are repelled down to the plate and the gold leaf. The leaf diverges due to presence of like charges at the plate and the leaf.

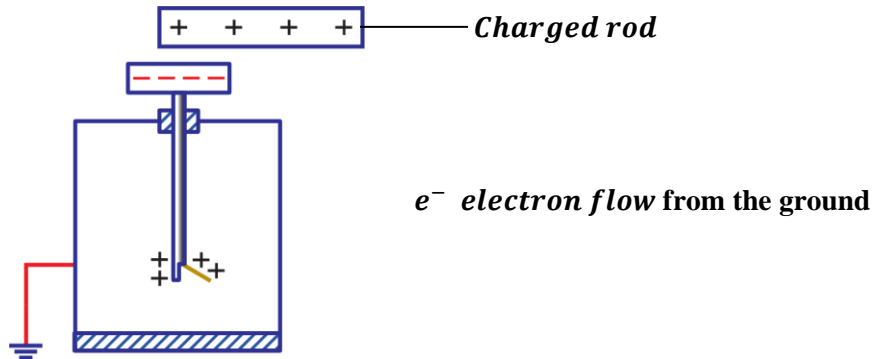

- With the charged rod still in position, the gold leaf electroscope is earthed by connecting it with an earth wire to the ground. Electrons flow from the ground through the earth wire to neutralize the positive charges at the plate and the leaf. This causes the leaf to collapse (decrease in divergence of the leaf)

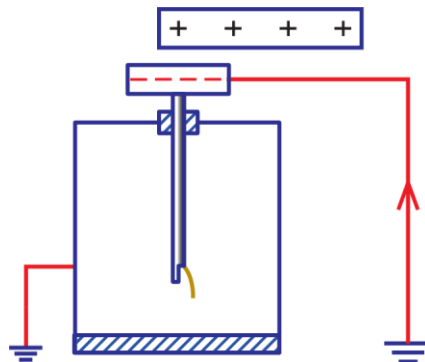

- With the charged rod still in position, the earthing is removed and then the charged rod is also removed.
- Negative charges distribute themselves all over the metal cap, plate and gold leaf. The leaf diverges again due to presence of like charges at the plate and the leaf.

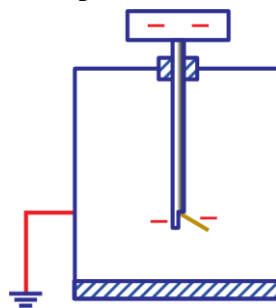

USES OR APPLICATIONS OF A GOLD LEAF ELECTROSCOPE:
(i) To detect the presence of charge on a body:

- Bring the body to be tested near the cap of an uncharged gold leaf electroscope.
- If the leaf diverges, then the body has a charge.
- If the leaf remains unchanged, then the body has no charge (neutral).

(ii) To test the sign or nature of charge on a body:

- Bring the body to be tested near the cap of a charged gold leaf electroscope.
- If the leaf divergence increases, then the body has a charge similar to that on the electroscope.
- If the leaf collapses (decrease in divergence), then the body either has a charge opposite to that on the electroscope or the body is neutral. In this case, we cannot conclude. But the G.L.E is discharged by touching its cap with a finger (earthing) and then given a charge opposite to the one it had previously and the experiment is repeated. If still the leaf collapses, then the body is neutral.

NOTE:

Increase in divergence is the only sure way of testing for sign of charge on the gold leaf electroscope.

Charge on G. L. E	Charge on a body	Effect of divergence of the leaf.
+	-	<i>Decrease</i>
+	+	<i>Increase</i>
-	-	<i>Increase</i>
-	+	<i>Decrease</i>
+	<i>No charge</i>	<i>Decrease</i>

(iii) To identify whether a body is an insulator or conductor:

- Bring a body to be tested in contact with the cap of a positively charged gold leaf electroscope.
- If the leaf collapses suddenly/immediately, then the body is a good conductor e.g. copper
- If the leaf collapses gradually/slowly, then the body is a semi-conductor e.g. silicon.
- If there is no change in divergence of the leaf, then the body is an insulator.

(iv) To test the magnitude of charge on the body:

- Two bodies of different sizes are similarly charged simultaneously.
- Each body is brought near the cap of the uncharged gold leaf electroscope one at a time.
- It is observed that a smaller body causes a smaller divergence of the leaf and the bigger body cause a greater divergence of the leaf.

(v) To compare and measure potentials:

- Two bodies are similarly charged simultaneously.
- Each body is brought in contact with the cap of a gold leaf electroscope one at a time.
- The divergences of the gold leaf in the two cases are noted and compared.
- The body which causes more divergence is at a higher potential than the other one.

Precautions taken when carrying out electrostatic experiments:

- The experiments should be carried out on a dry. *This because moisture/water conducts electricity thus giving out inaccurate values.*
- The plate and the cap of a gold leaf electroscope should always be kept clean and dry.
- The apparatus used must be insulated.
- Accidental touches from hands and clothes should be avoided.

Sample questions:

1. A charged rod was brought close to the cap of a negatively charged electroscope. It is observed that the leaf divergence increased as the rod was moved closer to the cap. Identify the charges on the rod.
A. Positive
B. Positive and negative
C. Negative
D. No charge.
2. State and explain the observation on the leaf of a positively charged electroscope when a negatively charged rod is brought close to its cap as shown below.

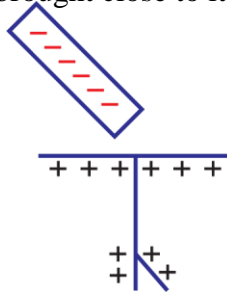

Observation: The leaf collapses.

Explanation: When a negatively charged rod was brought near the cap of the electroscope, it induced positive charges at the cap and repelled negative charges down to the plate and the gold leaf leading to neutralization of the positive charges thus the gold leaf collapses.

ELECTROPHORUS

This is a metal disk with an insulated handle placed on an insulating sheet previously charged by rubbing.

An electrophorus is used to produce unlimited charges by induction.

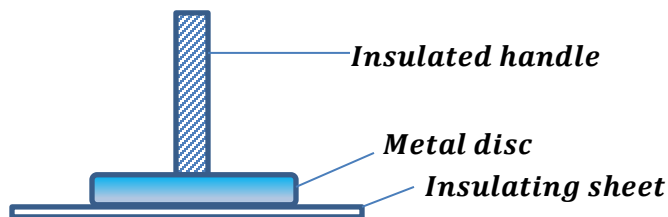

QN: Briefly describe how an electrophorus produces a positive charge.

- *An insulating sheet is given a negative charge by rubbing.*
- *A positive charge is induced on the lower part of the metal disc and a negative charge is repelled to the upper part.*
- *The upper part of the metal disc is earthed by touching it with a finger to remove the negative charges.*
- *Therefore, the metal disc is left with a net positive charge.*

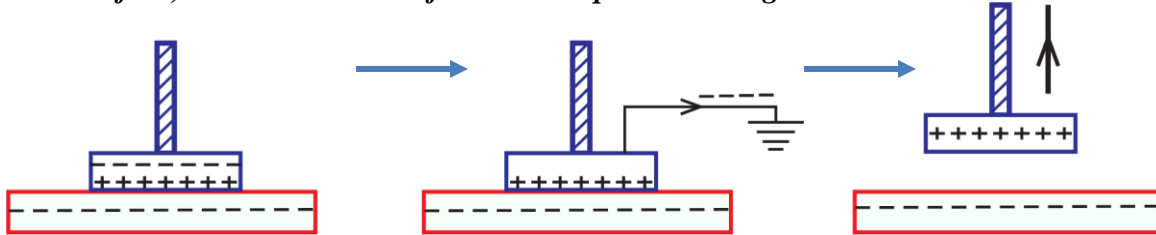

PROOF PLANE:

This is a device used to transfer charge from one conductor to another. It is the upper part of the electrophorus.

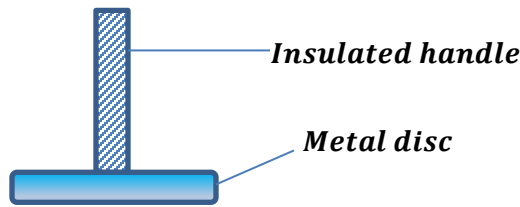

DISTRIBUTION OF CHARGE ON A CONDUCTOR

The distribution of charge on the surface of a conductor depends on the shape of that conductor. Charge is more concentrated at pointed edges of a conductor thus, there is a high surface charge density at sharp points.

Definition:

Surface charge density is the quantity of charge per unit area of the surface of a conductor.

Charge distribution over surfaces of conductors of different shapes:

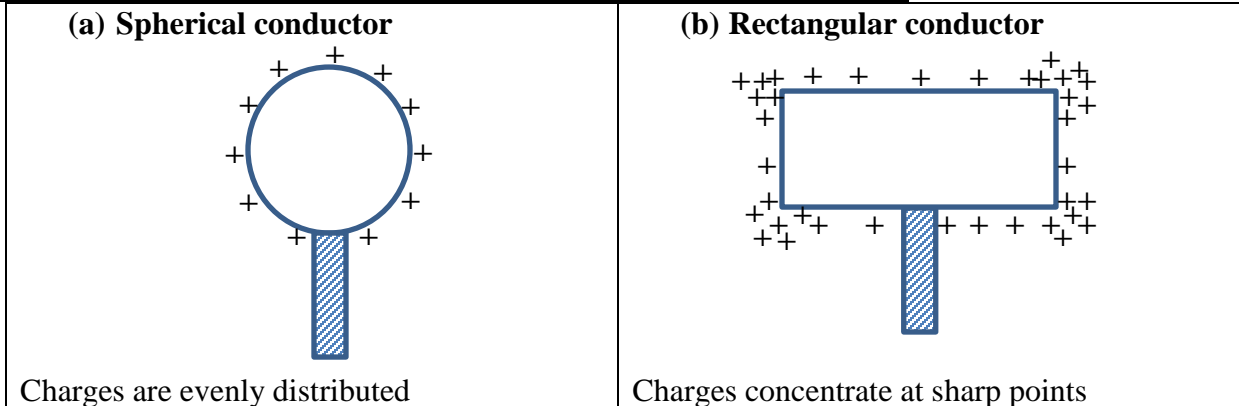

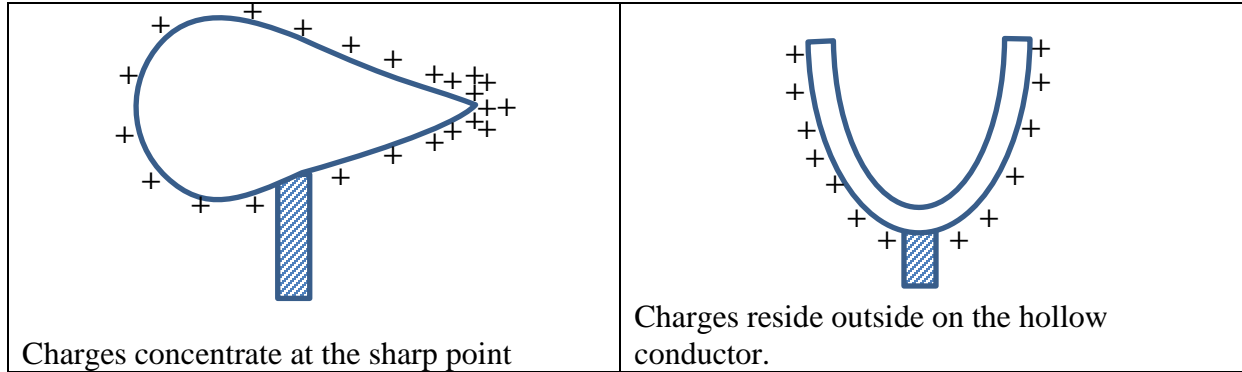

NOTE:

In a hollow conductor charges always reside outside the conductor. This was experimented by Faraday.

FARADAY'S ICE-PAIL EXPERIMENT

(An experiment to show charge distribution in a hollow conductor)

- Place an uncharged metal ice pail on the uncharged gold leaf electroscope.
- Suspend a positively charged metal sphere on a thread and lower it into the pail without touching the pail.

Observation: The gold leaf diverges indicating that charge has been induced on the outside of the pail.

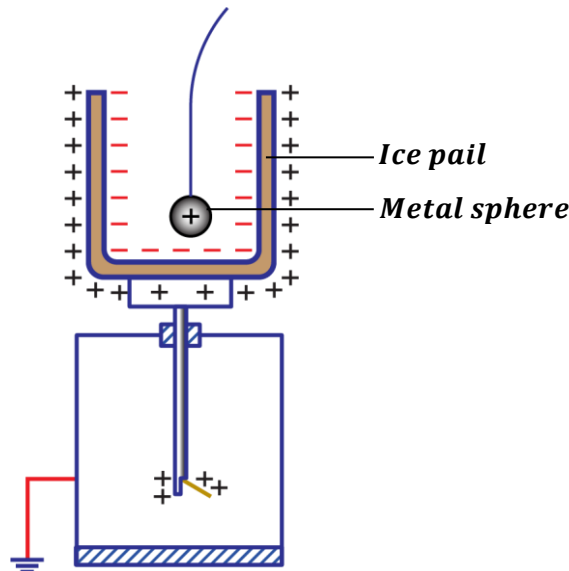

- Move the metal sphere in different positions inside the pail without touching the pail.

Observation: The divergence of the gold leaf does not change and when the metal sphere is completely removed from the pail and tested, it had all its charge.

- The metal sphere is again lowered in the pail and allowed to touch the bottom of the pail.

Observation: There is no change in divergence of the leaf but when the metal sphere is completely removed from the pail and tested, it had no charge.

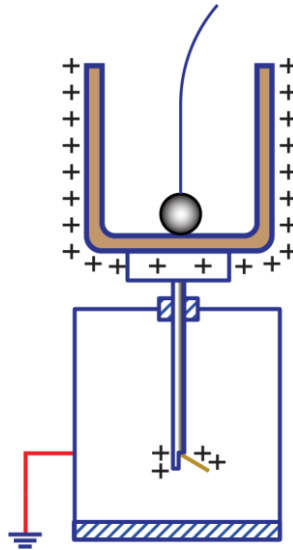
Conclusion:

- When the positively charged metal sphere touches the inside of the pail, the induced negative charges in the inside part of the pail neutralize the positive charge on the ball hence the ball remains with no charge.
- The net charge on the hollow conductor reside outside. This shows that there is no charge residing inside a charged hollow conductor.

Example:

1.

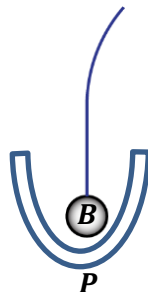

The figure above shows a negatively charged ball, B inside a metal conductor, P.

(a) Describe the distribution of charge on the metal conductor.

(i) Before B touches P

Positive charges are induced on the inside part of conductor, P and negative charges are to the outside part of conductor, P.

(ii) After B touching P

The negative charges on the ball, B neutralize the positive charges on the inside part of the conductor, P. therefore, conductor, P remains with no charge inside.

(b) After touching conductor, P, the ball is transferred to a positively charged electroscope and tested for its charge. State and explain what was observed.

There was no change in divergence of the gold leaf because the ball, B had lost its charge due to neutralization when it touched conductor, P.

ACTION AT SHARP POINTS

- The sharp points of a conductor have a high charge density which creates a strong electric field.
- The strong electric field ionizes the air around the sharp points forming positive and negative ions.
- Ions which have the same charge as that on the sharp points are repelled away and ions which have an opposite charge to that on the sharp points are attracted towards the sharp points resulting into neutralization of charge hence corona discharge.

Definition:

Corona discharge (charge leakage) is the process by which a pointed conductor apparently loses its charge.

NOTE:

The repelled ions from the sharp points form an electric wind which can blow a candle flame as shown below.

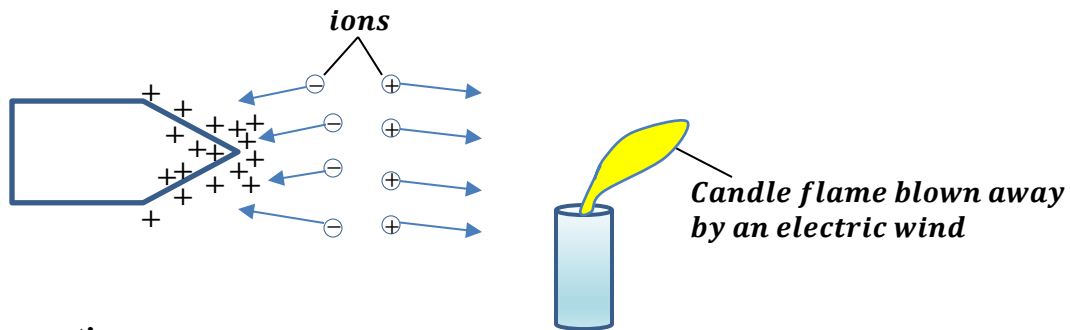
**Sample question:**

A highly charged positive sharp point is brought closer to a Bunsen burner flame.

- (i) State your observation.

The flame is blown away from the sharp points.

- (ii) Explain your observation.

Due to high charge density around the sharp point, the air around the sharp point is ionized forming positive and negative ions. Negative ions are attracted to the sharp point and positive ions are repelled away from the sharp point forming an electric wind which blows the candle flame.

EXERCISE:

1. What is meant by action at sharp points
2. Describe how corona discharge occurs at sharp points.

Application of action at sharp points (corona discharge):

- Used in a lightning conductor
- Used in electrostatic generators e.g Van de Graaff generator
- Used in electrostatic photocopying machines.

LIGHTNING

Lightning is a gigantic (very large) discharge between charges in clouds and the earth or between charges in the atmosphere and the earth.

- ❖ *Lightening occurs when strong negative charges in the clouds attract positive charges from the grounds and tall buildings. Due to neutralization of charges, a strong spark is developed which is seen as lightening.*

NOTE:

In order to minimize the effects of lightning, a lightning conductor is used to minimize the build-up of both charges at the clouds and the buildings by neutralizing them.

LIGHTNING CONDUCTOR OR ARRESTOR:

This is a device used to safe guard tall buildings from being struck/destroyed by lightning.

A lightning conductor consists of;

- **Spikes;** placed on top of a building.
- **Copper strip;** fixed to the ground and on the walls of the building from the spikes.
- **Copper plate;** buried under the ground.

How a lightning conductor works:

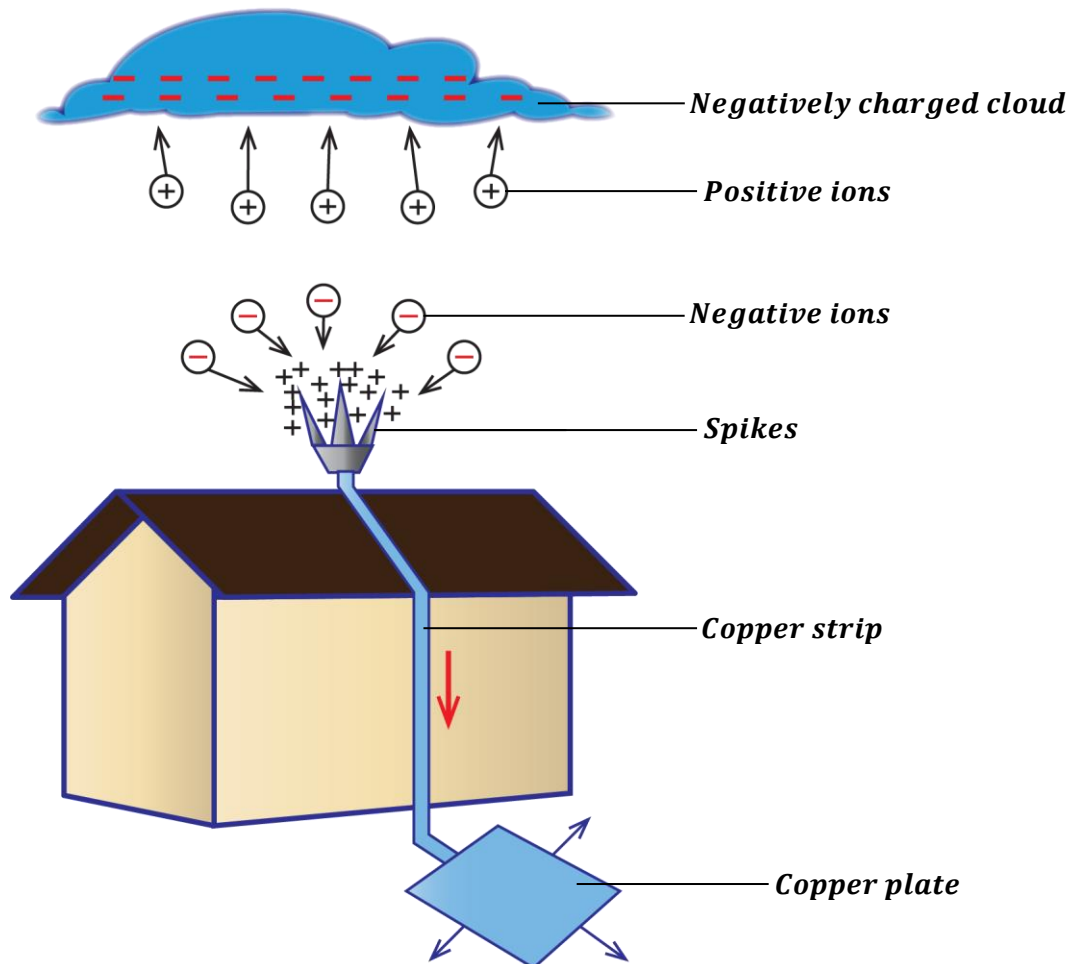

- When a negatively charged cloud passes over the lightning conductor, it induces positive charges on the spikes and repels negative charges to the ground through the copper strip.
- Due to the high charge density on the spikes, the air around the spikes is ionized forming positive and negative ions.
- Positive ions are repelled to the cloud and neutralize some of the negative charges on the cloud.
- Negative ions are attracted to the spikes and neutralize some of the positive charges at the spikes.
- This charge leakage on the clouds and building reduces the chances of lightning to occur.

Sample questions:

1. Explain why strips of a lightning conductor are made of thick copper wires.
 - *This is because copper is one of the best good conductors of electricity so it can easily allow the negatives charges (electrons) to pass through it to the ground.*
 - *When the copper wire is thick, it offers a low resistance to the flow of electrons through it.*
2. Explain why it's not advisable to touch the copper strip of a lightning conductor when it is raining.
When a negatively charged cloud passes over a lightning conductor, negative charges (electrons) are repelled to the ground through the copper strip. These moving electrons is electricity which can cause electric shocks to a person touching the copper strip.
3. Explain why the handle of an umbrella is made from a plastic material.
During a lightning, electric discharge (electricity) can shock a person holding an umbrella. Since a plastic material is an insulator, it does not allow electric discharge from lightning to reach the hands of the person holding the umbrella.
4. Explain why a person is not advised to take shelter under a tree when it is raining.
When its raining, lightning always strike/destroy tall objects. Most trees are tall and have pointed tips therefore, therefore there is a high charge density at these sharp points. As lightning strikes the tall tree, it can also strike the person under it.

ELECTRIC FIELD

This is the region around an electric charge where an electric force is experienced.
Electric fields are represented by electric field lines.

Definition:

An **electric field line** is a line drawn at any point in an electric field to show the direction of an electric force at that point.

Properties of electric field lines:

- They move from positive charge to negative charge.
- They do not cross each other.
- They repel one another side ways.
- They are in a state of tension.
- The number of electric field lines at certain point indicates the strength of the electric field.

ELECTRIC PATTERNS:

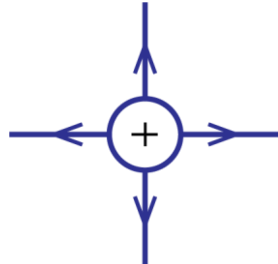
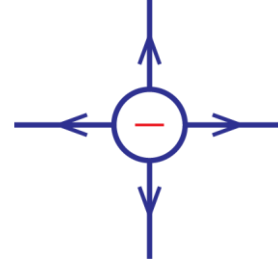
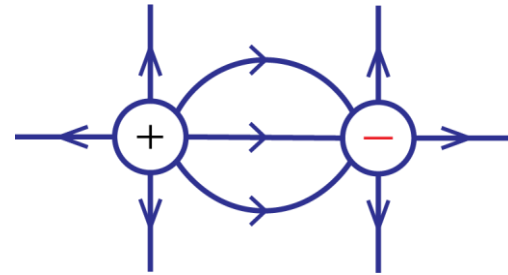
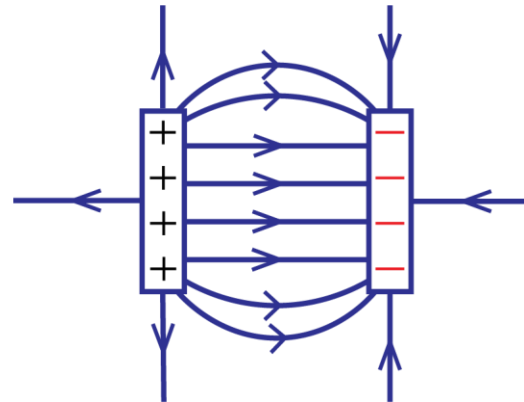
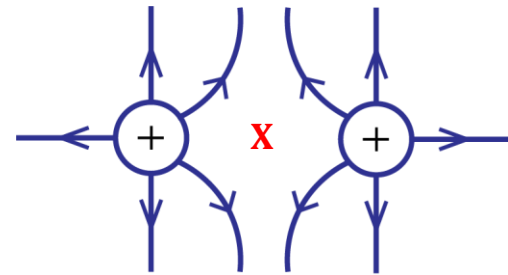
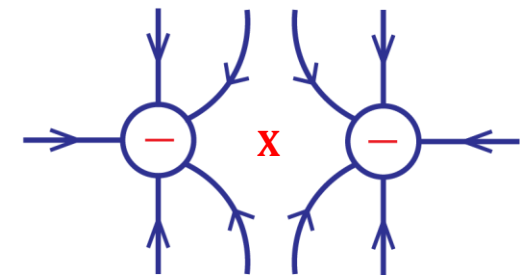
<p>(a) Isolated positive charge;</p> 	<p>(b) Isolated negative charge;</p> 
<p>(c) Two unlike charges;</p> 	<p>(d) Two plates of unlike charges;</p> 
<p>(e) Two unlike charges;</p>  <p>X is a neutral point</p> 	

Definition:

A **neutral point** is a point in an electric field where the net electric force is zero.

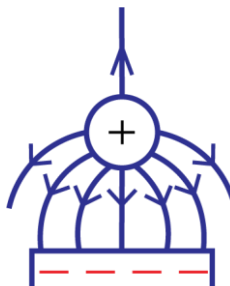
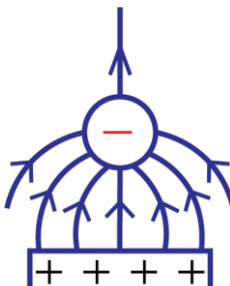
<p>(f) A positive charge near a negative plate;</p> 	<p>(g) A negative charge near a positive plate;</p> 
---	--

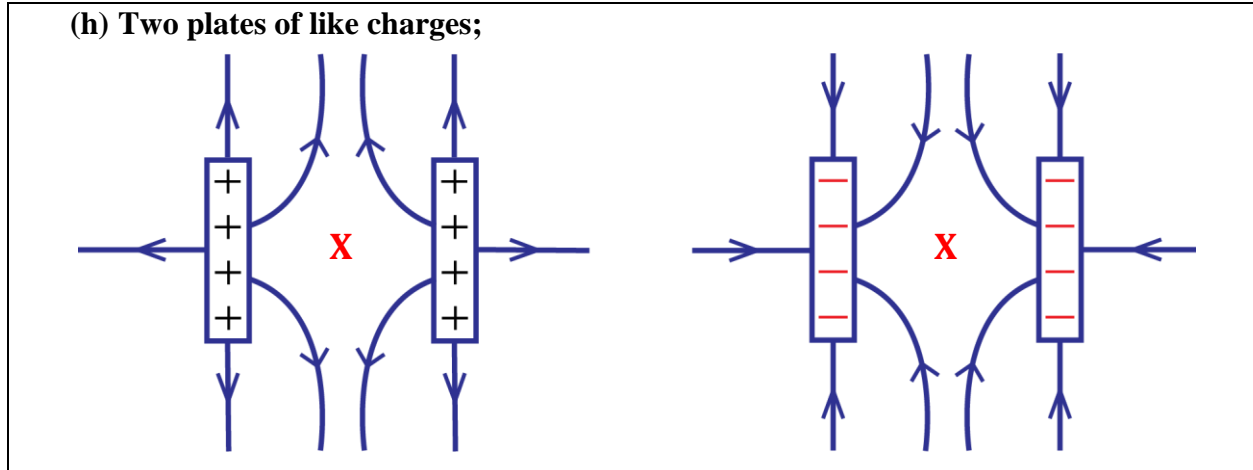

Applications of electrostatic physics:

- Used in a lightning conductor
- Used in electrostatic generators e.g. Van de Graaff generator
- Used in electrostatic photocopying machines.
- Used in laser printers.
- Used in electrostatic precipitators for cleaning air.

EXERCISE:

1. (a) Explain why a pen rubbed with a piece of cloth attracts small pieces of paper.
 (b) Why is it difficult to perform electrostatic experiments under damp conditions?
 (c) Explain why a handle of a proof plane is made of an insulator.
 (d) State three applications of electrostatic physics in the real world.

2. (a) sketch electric field patterns for the following.
 - (i) Two negative charges close to each other.
 - (ii) A positively charged conducting sphere.
 - (iii) Two oppositely charged parallel plates
 (b) Explain how an insulator gets charged by rubbing.
 (c) Describe how lightning conductors safe guard tall buildings from being destroyed by lightning.

CURRENT ELECTRICITY

Current electricity is the flow of charged particles from one point to another e.g. electrons. Electrical devices which use electricity are called electrical appliances.

Sources of electricity/emf include;

- Batteries
- Generators
- Solar panels/solar energy.
- Wind mills

TERMS USED IN ELECTRICITY;

CHARGE(Q):

This is the quantity of electricity which passes any point in a conductor. The SI unit of charge is a coulomb (C).

ELECTRIC CURRENT (I):

Charges move from one point to another in a given time. This rate of flow is called electric current.

Definition:

Electric current is the rate of flow of charge in a conductor.

The SI unit of current is the ampere (A).

$$\text{Current (I)} = \frac{\text{Charge (Q)}}{\text{Time (t)}}$$

$$I = \frac{Q}{t}$$

Note:

- The time should always be in seconds.
- Current is measured by an instrument called an ammeter.

Definition:

An **ampere** is the constant current when a charge of 1C flows in a conductor in one second.

OR

An **ampere** is current which when flowing in two straight parallel wires of infinite length placed one meter apart in a vacuum produce a force of $2 \times 10^{-7} Nm^{-1}$ on each of the wires.

But also $Q = It$ implying that $1C = 1A \times 1s$

Definition:

A **coulomb** is the quantity of charge which passes any point of a conductor in one second when a current of one ampere is flowing in the conductor.

Other units of current include;

$$1mA = 1 \times 10^{-3}A$$

$$1\mu A = 1 \times 10^{-6}A$$

Examples:

1. A current of 6A flows for 2 hours in a circuit. Calculate the quantity of electricity that flows in this time.

$$Q = It$$

$$Q = 6 \times 2 \times 3600$$

$$Q = 43200C$$

2. A charge of 2550C flows past a point in a circuit in 25minutes. Find the current flowing.

$$Q = 2550C, \quad t = 25mins = 25 \times 60 = 1500s$$

$$Q = It$$

$$2550 = I \times 1500$$

$$I = \frac{2550}{1500}$$

$$I = 1.7A$$

3. A current of 6mA flows for 2 hours in a circuit. Find the quantity of charge.

$$Q = ?, \quad t = 2 hrs = 2 \times 3600 = 7200s, \quad I = 6mA = \frac{6}{1000} = 0.006A$$

$$Q = It$$

$$Q = 0.006 \times 7200$$

$$Q = 43.2C$$

4. A charge of 20 kC crosses two sections of a conductor in 1minute. Find the current through the conductor.

$$Q = 20kC = 20 \times 1000 = 20000C, \quad t = 1min = 1 \times 60 = 60s$$

$$Q = It$$

$$20000 = I \times 60$$

$$I = \frac{20000}{60}$$

$$I = 333.3A$$

POTENTIAL DIFFERENCE (p.d):

This is the work done in joules when one coulomb of charge moves from one point to another in a circuit.

If two points in a conductor are of different electric potentials, then a charge can move from one point to another and work is said to be done. Potential difference is sometimes referred to as **voltage**. The instrument used to measure potential difference is a **voltmeter**.

The SI unit of potential difference is the Volt (V).

Definition:

A **volt** is the potential difference between two points in a circuit when one joule of work is done to move one coulomb of charge from one point to another.

ELECTROMOTIVE FORCE (emf):

This is the work done in joules when one coulomb of charge moves from one point to another in a circuit in a cell is connected.

The SI unit of emf is the Volt (V).

Sources of emf include; cells, generators, solar cells etc.

ELECTRICAL RESISTANCE (R):

This is the opposition to flow of current in a conductor.

The SI unit of resistance is an ohm (Ω).

Definition:

An **Ohm** is the resistance of a conductor in which a current of 1A flows when a potential difference of one volt is applied across its ends.

INTERNAL RESISTANCE OF A CELL (r):

This is the opposition to flow of current within the cell.

FACTORS THAT AFFECT RESISTANCE OF A CONDUCTOR:
(i) Length:

The resistance of a conductor is directly proportional to the length of a conductor ($R \propto L$).

Resistance of a conductor increases when its length increase. Therefore, the shorter the wire, the lower the resistance and the longer the wire, the higher the resistance.

(ii) Cross-sectional area:

The resistance of a conductor is inversely proportional to its cross-sectional area. ($R \propto \frac{1}{A}$).

Thin wires have a high resistance while thicker wires have a low resistance.

(iii) Temperature:

The resistance of a pure metals like copper increase when their temperatures increase.

(iv) Nature of conductor:

Good conductors like metals have a lower resistance compared to the bad conductors.

Note; The first two factors can be combined as

$$R \propto \frac{L}{A}$$

$$R = \rho \frac{L}{A}$$

where ρ is resistivity in Ωm

Examples:

1. A conductor of length 20m has a cross sectional area of $2 \times 10^{-4} m^2$. Its resistance is 0.6Ω . Find the resistivity of the conductor.

$$R = \rho \frac{L}{A}$$

$$0.6 = \rho \times \frac{20}{2 \times 10^{-4}}$$

$$\rho = \frac{0.6 \times 2 \times 10^{-4}}{20}$$

$$\rho = 6 \times 10^{-4} \Omega m$$

2. A wire of cross-sectional area of $0.002 m^2$ and length 2m has its resistivity as $1.0 \times 10^{-7} \Omega m$. What is its resistance?

$$R = \rho \frac{L}{A}$$

$$R = 1.0 \times 10^{-7} \times \frac{2}{0.002} = 0.0001 \Omega$$

ELECTRIC CIRCUIT:

This is the path followed by current.

Types of circuits include;

- **Open circuit:** This is a circuit in which current is not flowing to the external circuit.

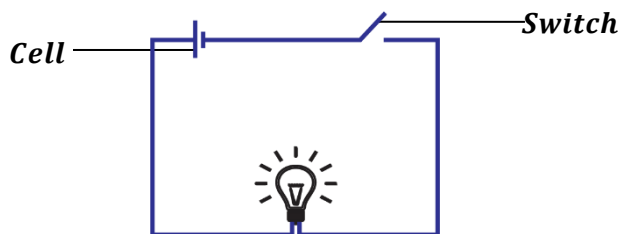



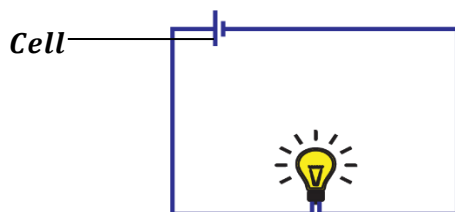









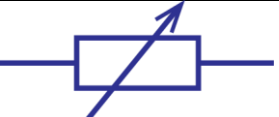

- **Closed circuit:** This is a circuit in which current is flowing to the external circuit.

Note:

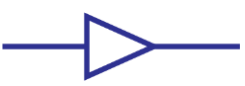
A **short circuit** is a low resistance path for the flow of current.

It occurs when two points in a circuit are directly connected so that current flows through a shorter distance. This increases the flow of current hence damaging the circuit.

ELECTRICAL SYMBOLS IN ELECTRICAL CIRCUITS.

SYMBOL	NAME	SYMBOL	NAME
	Standard resistor		Galvanometer
	Variable resistor (Rheostat)		Alternating current supply
	Switch	 	Bulbs/lamps
	Cell		Capacitor
	Diode		Crossing wires
	Battery/accumulator		Connected wires
	Ammeter		Voltmeter

OHM'S LAW

It states that current flowing through a metallic conductor is directly proportional to the potential difference across its ends provided temperature and other physical conditions are remain constant.

$p.d \propto \text{current}$

$$V \propto I$$

$$V = RI$$

$$\boxed{V = IR}$$

Where **R**-resistance of conductor.

V-potential difference.

I-current.

Examples:

1. Calculate the potential difference across a 10Ω resistor carrying a current of 2A.

$$\begin{aligned} V &= IR \\ V &= 2 \times 10 \\ V &= 20V \end{aligned}$$

2. The voltage across a 2Ω resistor is 4V. What is the current flowing?

$$\begin{aligned} V &= IR \\ 4 &= I \times 2 \\ I &= \frac{4}{2} \\ I &= 2A \end{aligned}$$

3. Find the potential difference across a conductor of resistance 2Ω if the charge of 180C flows for 2 minutes.

$R = 2\Omega,$	$Q = 180C,$	$t = 2\text{mins} = 2 \times 60 = 120s$	
	$\text{But } I = \frac{Q}{t}$	$V = IR$	
	$I = \frac{180}{120}$	$V = 1.5 \times 2$	
	$I = 1.5A$	$V = 3V$	

4. What voltage is needed to make a current of 0.4A flow through when the appliance has resistance of 20Ω ?

$$\begin{aligned} V &= IR \\ V &= 0.4 \times 20 \\ V &= 8V \end{aligned}$$

5. A current of 4A flows through an electric kettle when the p.d. across it is 8V. Find the resistance.

$$\begin{aligned} V &= IR \\ 8 &= 4 \times R \\ R &= \frac{8}{4} \\ R &= 2\Omega \end{aligned}$$

Experiment to verify ohm's law.

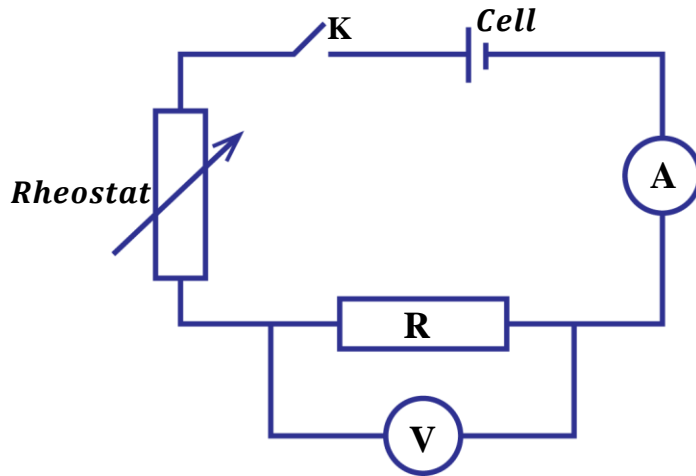

- The circuit is connected as shown above.
- Switch **K** is closed and the current flows through the circuit.
- Read and record the ammeter and voltmeter readings **I** and **V** respectively.
- The rheostat is adjusted to obtain several values of **I** and **V** and the results are tabulated.
- Plot a graph of **V** against **I**.

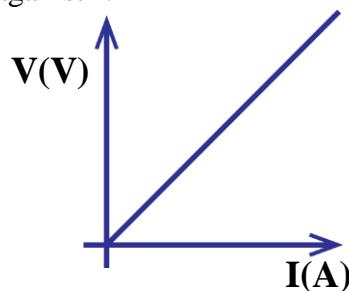

- A straight line is obtained showing that potential difference, **V** is directly proportional to current, **I**.

Limitations of ohm's law:

- The law only applies when the physical conditions of a conductor are constant e.g. temperature.
- The law doesn't apply to semiconductors e.g. diodes and electrolytes.

OHMIC AND NON OHMIC CONDUCTORS

Ohmic conductors:

These are conductors which obey ohm's law.
They include; metals e.g. copper, iron. Zinc etc.
When a graph of **I** against **V** is plotted, a straight line is obtained.

Non-ohmic conductors:

These are conductors which do not obey ohm's law.
They include; filament lamps, diodes, neon gas etc.
When a graph of I against V is plotted, a non-straight line is obtained.

Graphs of current against voltage for different conductors (characteristic curves):

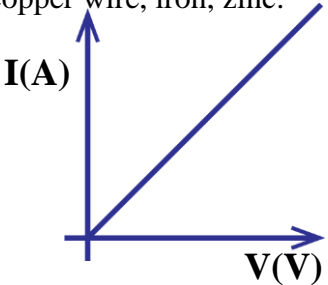
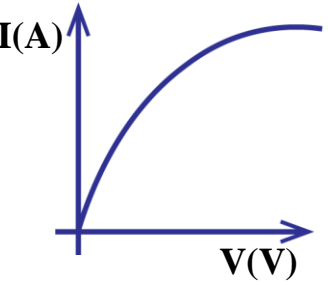
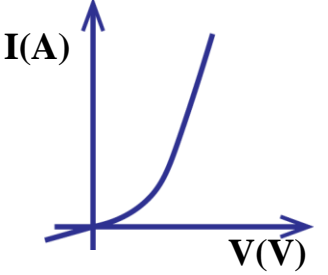
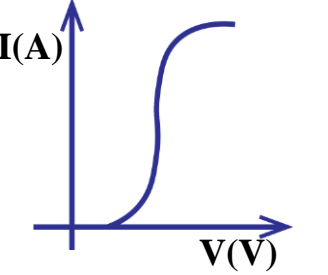
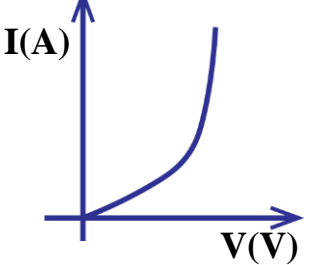
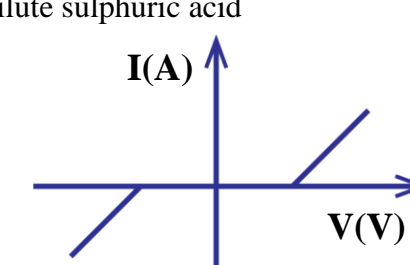
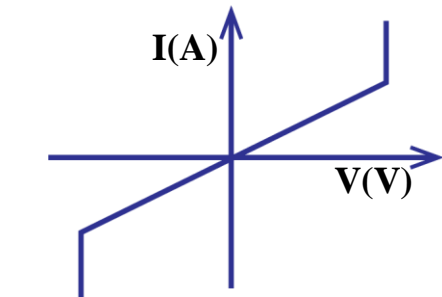
<p><u>Ohmic conductor;</u> e.g. copper wire, iron, zinc.</p> 	<p><u>Filament lamp;</u></p> 
<p><u>Semi-conductor diode;</u></p> 	<p><u>Vacuum or Thermionic diode;</u></p> 
<p><u>Thermistor or Carbon resistor;</u></p> 	<p><u>Electrolyte;</u> e.g. dilute sulphuric acid</p> 
<p><u>Neon gas;</u></p> 	

CIRCUITS CONNECTION
Ammeter:

This is an electrical device used to measure current in a physics laboratory.

An ammeter has a very low resistance i.e. 0Ω

QN: Why is an ammeter constructed with a low resistance.

*To allow all the current to be accurately measured without being affected by the resistance.
The low resistance ensures that all the current to be measured passes through the ammeter without being opposed/resisted.*

The ammeter is always connected in series i.e. it is placed in the path of current.

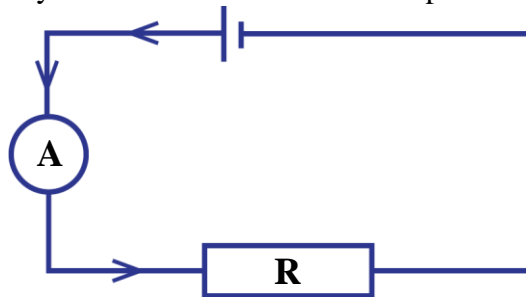
Ammeter:

This is an electrical device used to measure potential difference or voltage in a physics laboratory.

A voltmeter has a very high resistance.

QN: Why is a voltmeter constructed with a very high resistance.

It has a very high resistance so as to draw a very low current from the source thus not affecting the total current in the circuit.

The voltmeter is always connected in parallel with the source of current.

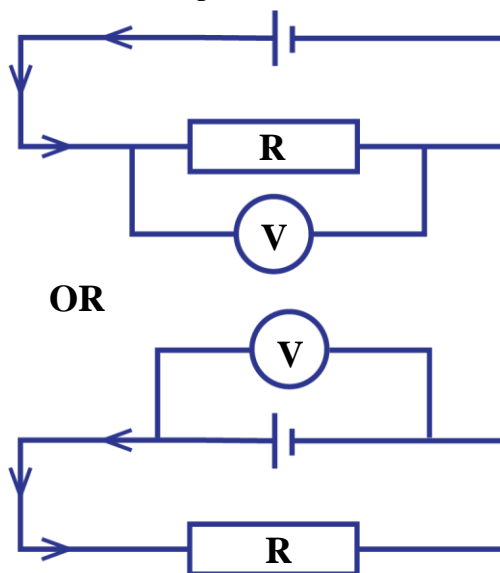

RESISTORS

A **resistor** is a device which opposes the flow of current in a circuit.
In a circuit, resistors are either arranged in series or in parallel.

Types of resistors:

(i) **Standard resistors:**

These are resistors whose resistances are known e.g. 2Ω , 5Ω , 10Ω etc.

(ii) **Variable resistors/Rheostats:**

These are resistors whose resistances can be varied by moving a slider.

The amount of current in the circuit can be varied by adjusting the rheostat.

Series arrangement of resistors:

Resistors are said to be in series if they are connected end to end so that the same current passes through them.

Note: In series;

- The same amount of current flows through each resistor.
- P.d or voltage across each resistor is different.
- Total voltage is equal to sum of individual voltages across each resistor.

Consider three resistors R_1 , R_2 and R_3 connected in series across a potential difference, V .

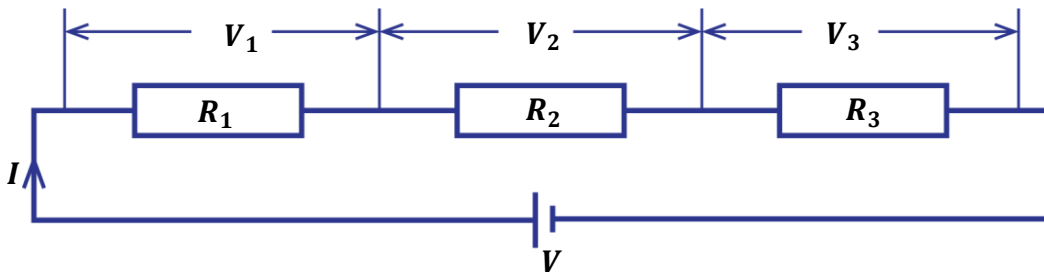

$$V = V_1 + V_2 + V_3$$

from ohm's law $V = IR$ i.e. $V_1 = IR_1, V_2 = IR_2, V_3 = IR_3$

$$IR = IR_1 + IR_2 + IR_3$$

$$IR = I(R_1 + R_2 + R_3)$$

$$\frac{IR}{I} = \frac{I(R_1 + R_2 + R_3)}{I}$$

$R = R_1 + R_2 + R_3$

Effective resistance

Note:

All electrical appliances e.g. lamps, bulbs etc. connected in series have the same amount of current flowing through them.

Parallel arrangement of resistors:

Resistors are said to be in parallel if they are connected side by side with their adjacent ends joined together at a common point.

Note: In parallel;

- P.d across each resistor is the same.
- Current flow in the circuit splits and therefore, current through each resistor is different.
- Total current is equal to sum of individual currents through each resistor.

Consider three resistors R_1 , R_2 and R_3 connected in parallel across a potential difference, V .

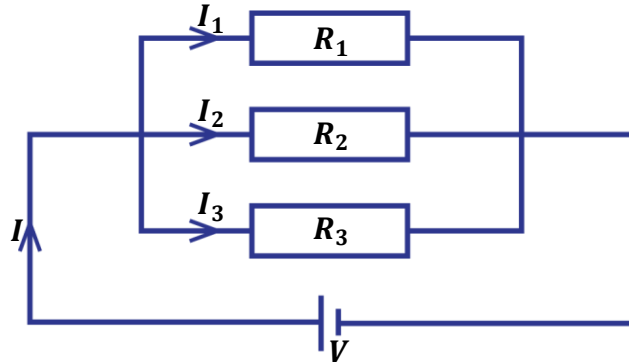

$$I = I_1 + I_2 + I_3$$

from ohm's law $V = IR$ i.e. $I = \frac{V}{R}$, $I_1 = \frac{V}{R_1}$, $I_2 = \frac{V}{R_2}$, $I_3 = \frac{V}{R_3}$

$$\frac{V}{R} = \frac{V}{R_1} + \frac{V}{R_2} + \frac{V}{R_3}$$

$$\frac{V}{R} = V\left(\frac{1}{R_1} + \frac{1}{R_2} + \frac{1}{R_3}\right)$$

dividing through by V on both sides

$$\boxed{\frac{1}{R} = \frac{1}{R_1} + \frac{1}{R_2} + \frac{1}{R_3}}$$

Where R is **Effective resistance**

Note:

For two resistors connected in parallel;

$$\frac{1}{R} = \frac{1}{R_1} + \frac{1}{R_2}$$

$$\frac{1}{R} = \frac{R_1 + R_2}{R_1 R_2}$$

$$\boxed{R = \frac{R_1 R_2}{R_1 + R_2}}$$

Therefore, effective resistance,

$$R = \frac{\text{Product}}{\text{Sum}}$$

Examples:

Find the effective resistance in the following diagrams.



$$R = R_1 + R_2$$

$$R = 10 + 11$$

$$R = 21\Omega$$

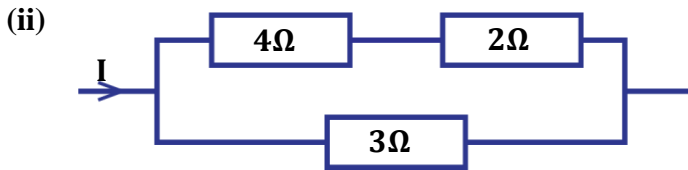

for series connection;

$$R_s = R_1 + R_2$$

$$R_s = 4 + 2$$

$$R_s = 6\Omega$$

for parallel connection;

$$\frac{1}{R} = \frac{1}{R_s} + \frac{1}{R_3}$$

$$\frac{1}{R} = \frac{1}{6} + \frac{1}{3}$$

$$\frac{1}{R} = \frac{1}{6} + \frac{2}{6}, \quad R = \frac{6}{3}$$

effective resistance, $R = 2\Omega$

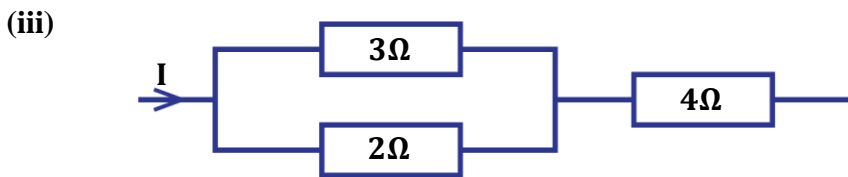

for parallel connection;

$$\frac{1}{R_p} = \frac{1}{R_1} + \frac{1}{R_2}$$

$$\frac{1}{R_p} = \frac{1}{3} + \frac{1}{2}$$

$$\frac{1}{R_p} = \frac{2}{6} + \frac{3}{6}, \quad R_p = \frac{6}{5}$$

$$R_p = 1.2\Omega$$

OR

for series connection;

$$R = R_p + R_3$$

$$R = 1.2 + 4$$

effective resistance, $R = 5.2\Omega$

$$R = \frac{3 \times 2}{3 + 2} + 4$$

$$R = 1.2 + 4$$

$$R = 5.2\Omega$$

(iv)

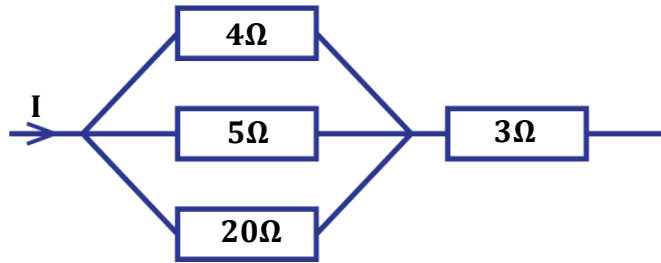

for parallel connection;

$$\frac{1}{R_p} = \frac{1}{R_1} + \frac{1}{R_2} + \frac{1}{R_3}$$

$$\frac{1}{R_p} = \frac{1}{4} + \frac{1}{5} + \frac{1}{20}$$

$$\frac{1}{R_p} = \frac{10}{20}, \quad R_p = \frac{20}{10}$$

$$R_p = 2\Omega$$

for series connection;

$$R = R_p + R_3$$

$$R = 2 + 3$$

effective resistance, $R = 5\Omega$

(v)

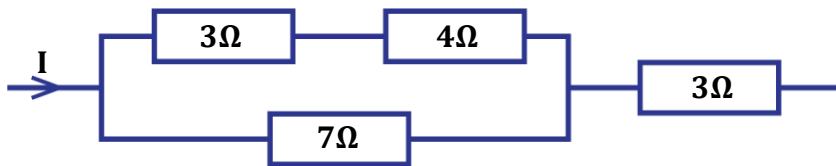

for series connection;

$$R_s = R_1 + R_2$$

$$R_s = 3 + 4$$

$$R_s = 7\Omega$$

$$\text{then } R = \frac{R_s R_2}{R_s + R_2} + R_3$$

$$R = \frac{7 \times 7}{7 + 7} + 3$$

$$R = 3.5 + 3$$

$$R = 6.5\Omega$$

(vi)

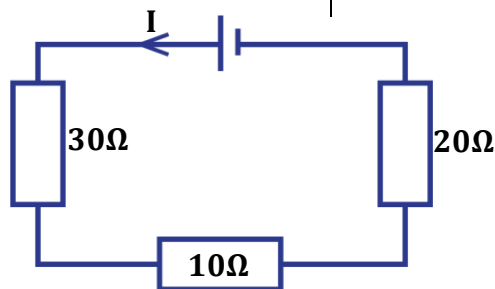

$$R = R_1 + R_2 + R_3$$

$$R = 30 + 10 + 20$$

$$R = 60\Omega$$

(vii)

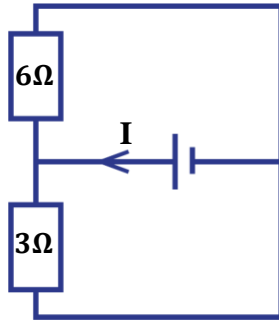

$$R = \frac{R_1 R_2}{R_1 + R_2}$$

$$R = \frac{6 \times 3}{6 + 3}$$

$$R = 2\Omega$$

(viii)

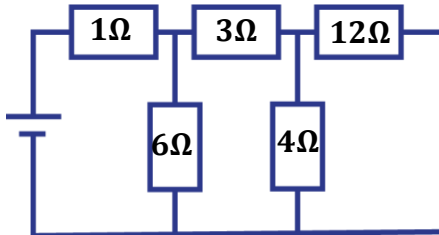

$$R = R_1 + \frac{R_2 R_3}{R_2 + R_3} + \frac{R_4 R_5}{R_4 + R_5}$$

$$R = 1 + \frac{3 \times 6}{3 + 6} + \frac{4 \times 12}{4 + 12}$$

$$R = 1 + 2 + 3$$

$$R = 6\Omega$$

EXERCISE:

Find the effective resistance in the following diagrams.

<p>1.</p>	<p>2.</p>
<p>3.</p>	<p>4.</p>

CONNECTION OF CELLS:

Cells provide us with emfs and these emfs can be arranged in series or in parallel.

Series arrangement of cells:

Cells are said to be in series if the positive terminal of one cell is connected to negative terminal of another cell.

The total emf of the cells is equal to the sum of individual emfs.

Consider three cells each of emf, E and internal resistance, r connected in series as shown below.

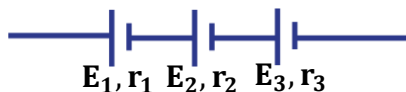

$$\begin{aligned} \text{Total emf, } E &= E_1 + E_2 + E_3 \\ \text{Total internal resistance, } r &= r_1 + r_2 + r_3 \end{aligned}$$

Parallel arrangement of cells:

Cells are said to be in parallel if the positive terminals of the cells are connected to one point and the negative terminals of cells are connected to another point.

The total emf is equal to one of the emfs of the cell.

Consider three cells each of emf, E and internal resistance, r connected in series as shown below.

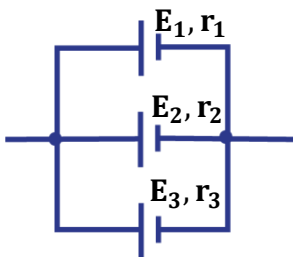

$$\begin{aligned} \text{Total emf, } E &= E_1 = E_2 = E_3 \\ \text{Total internal resistance, } \frac{1}{r} &= \frac{1}{r_1} + \frac{1}{r_2} + \frac{1}{r_3} \end{aligned}$$

Note:

Consider a cell of emf, E and internal resistance, r connected in series to a standard resistor, R .

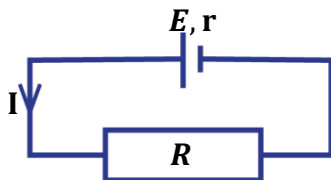

total/effective resistance = $(R + r)$
from ohm's law $V = IR$
therefore $E = I(R + r)$
 $E = IR + Ir$

$$E = IR + Ir$$

Terminal p.d lost p.d due to internal resistance

Definition:

Terminal p.d is the voltage across the terminals of a cell when current is being delivered to an external circuit.

QN: Explain why terminal p.d is less than the actual emf of a cell.

Terminal p.d is always less than the emf because of the opposition to flow of current within a cell i.e. internal resistance.

EXAMPLES:

1. Find the total emf and total internal resistance in the following circuits if each cell has an emf of 1.5V and internal resistance of 1Ω



$$\begin{aligned} \text{Total emf,} \\ E &= E_1 + E_2 + E_3 \\ E &= 1.5 + 1.5 + 1.5 + 1.5 \\ E &= 6V \end{aligned}$$

$$\begin{aligned} \text{Total internal resistance,} \\ r &= r_1 + r_2 + r_3 + r_4 \\ r &= 1 + 1 + 1 + 1 \\ r &= 4\Omega \end{aligned}$$

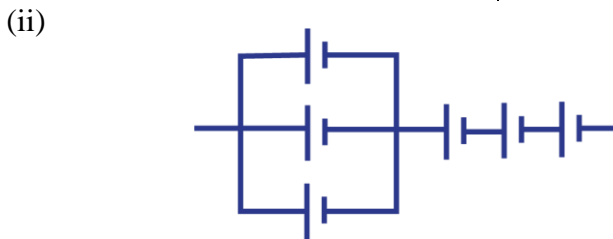

$$\begin{aligned} \text{Total emf,} \\ E &= 1.5 + 1.5 + 1.5 + 1.5 \\ E &= 6V \end{aligned}$$

$$\begin{aligned} \text{Total internal resistance,} \\ r &= \left[\frac{1}{r_1} + \frac{1}{r_2} + \frac{1}{r_3} \right] + r_4 + r_5 + r_6 \\ r &= \left[\frac{1}{1} + \frac{1}{1} + \frac{1}{1} \right] + 1 + 1 + 1 \\ r &= 6\Omega \end{aligned}$$

2. Find the ammeter reading in the circuit diagram below.

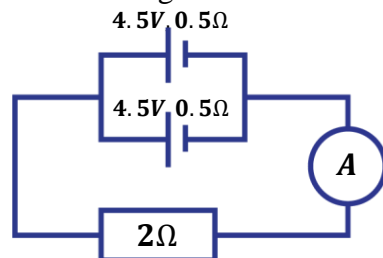

$$\begin{aligned} \text{total emf, } E &= 4.5V \\ \text{total internal resistance, } r &= \frac{0.5 \times 0.5}{0.5 + 0.5} \\ r &= 0.25\Omega \\ \text{effective resistance, } R &= 2\Omega \end{aligned}$$

$$\begin{aligned} E &= I(R + r) \\ 4.5 &= I(2 + 0.25) \\ 4.5 &= I(2.25) \\ I &= \frac{4.5}{2.25} \\ \text{Ammeter reading } I &= 2A \end{aligned}$$

3. Eight identical cells each of emf 1.5V and internal resistance 0.1Ω are connected in a circuit as shown below. Find the current flowing.

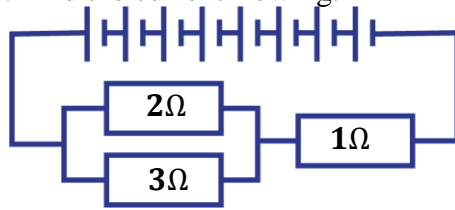

<p>total emf, $E = 1.5 \times 8 = 12V$</p> <p>total internal resistance, $r = 0.1 \times 8$ $r = 0.8\Omega$</p> <p>effective resistance, $R = \frac{R_1 R_2}{R_1 + R_2} + R_3$</p> <p>$R = \frac{2 \times 3}{2 + 3} + 1$</p> <p>$R = 1.2 + 1$</p> <p>$R = 2.2\Omega$</p>	<p>$E = I(R + r)$</p> <p>$12 = I(2.2 + 0.8)$</p> <p>$12 = I(3)$</p> <p>$I = \frac{12}{3}$</p> <p>current $I = 4A$</p>
---	--

4. A battery of 4 cells each of emf 1.5V and negligible internal resistance are connected in the circuit with 3 bulbs each of resistance 0.8Ω . Calculate the current flowing in the circuit.

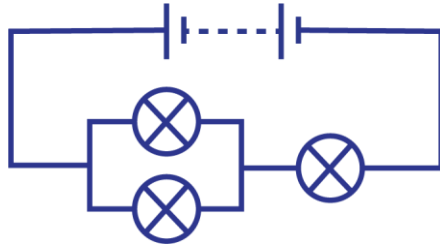

<p>total emf, $E = 1.5 \times 4 = 6V$</p> <p>total internal resistance, $r = 0\Omega$</p> <p>effective resistance, $R = \frac{R_1 R_2}{R_1 + R_2} + R_3$</p> <p>$R = \frac{0.8 \times 0.8}{0.8 + 0.8} + 0.8$</p> <p>$R = 0.4 + 0.8$</p> <p>$R = 1.2\Omega$</p>	<p>$E = I(R + r)$</p> <p>$6 = I(1.2 + 0)$</p> <p>$6 = I(1.2)$</p> <p>$I = \frac{6}{1.2}$</p> <p>current $I = 5A$</p>
--	---

EXPERIMENT TO DETERMINE INTERNAL RESISTANCE OF A CELL
Method 1: Using a voltmeter and standard resistor

- Measure the emf, E of the cell by connecting the terminals of the cell to the voltmeter.
- Connect a cell in series with a switch, K and a standard resistor, R .
- Connect a voltmeter across the standard resistor as shown below.

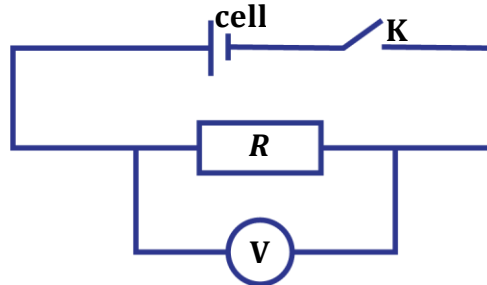

- Switch, K is then closed and the voltmeter reading V is noted and recorded.
- The internal resistance, r is got from $r = \frac{R(E-V)}{V}$

$$\begin{aligned}
 E &= IR + Ir \\
 &\text{from Ohm's, law} \\
 V &= IR \text{ and } I = \frac{V}{R} \\
 \text{then } E &= V + \frac{V}{R}r \\
 \text{therefore, } r &= \frac{R(E-V)}{V}
 \end{aligned}$$

Method 2: Using a voltmeter, ammeter and standard resistor

- Measure the emf, E of the cell by connecting the terminals of the cell to the voltmeter.
- Connect a cell in series with a switch, K , an ammeter, A and a standard resistor, R .
- Connect a voltmeter across the standard resistor as shown below.

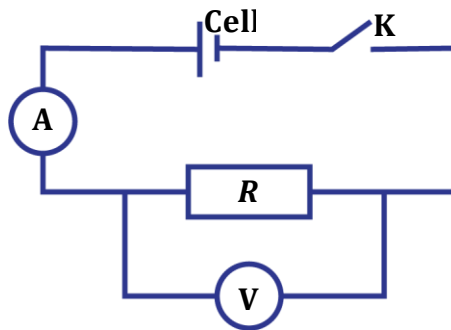

- Switch, K is then closed and the ammeter and voltmeter readings I and V are noted and recorded.
- The internal resistance, r is got from $r = \frac{E-V}{I}$

$$\begin{aligned}
 E &= IR + Ir \\
 &\text{from Ohm's, law} \\
 V &= IR \\
 \text{then } E &= V + Ir \\
 \text{therefore, } r &= \frac{E-V}{I}
 \end{aligned}$$

ELECTRICAL ENERGY AND POWER
ELECTRICAL ENERGY:

Electrical energy is the work done in moving an electric charge by an electric force.

The SI unit of electrical energy is the Joule (**J**)

This electrical energy is accompanied with a rise in temperature so this energy may be given out as heat energy.

This explains why wires become hot when electricity passes through them.

QN: Explain electrical wires (metals) heat up when electricity passes through them.

As current is switched on, electrons start moving through the wire. Due to resistance of the wire, the electrons are opposed from moving and they collide with the molecules of the wire. They lose some of their kinetic energy to the molecules of the wire which causes a rise in temperature (heat energy).

Simple derivations for work done

Work done = potential difference × charge

$$W = QV$$

$$\text{but } Q = It$$

$$\boxed{W = VIt} \text{ ---(1)}$$

But from Ohm's law $V = IR$ (substitute in equation 1)

$$\text{then } W = IR \times I \times t$$

$$\boxed{W = I^2Rt}$$

But from Ohm's law $V = IR \Rightarrow I = \frac{V}{R}$ (substitute in equation 1)

$$\text{thus } W = V \times \frac{V}{R} \times t$$

$$\boxed{W = \frac{V^2}{R}t}$$

ELECTRICAL POWER:

This is the rate of doing work on a charged particle.
The SI unit of electrical power is the Watt (**W**).

$$Power = \frac{Work\ done}{Time}$$

but work done, $W = VIt$

$$P = \frac{VIt}{t}$$

$$\boxed{P = IV} \text{ ----- (2)}$$

but from Ohm's law $V = IR$ (substitute in equation 2)
 $P = I \times IR$

$$\boxed{P = I^2 R}$$

But from Ohm's law $V = IR \Rightarrow I = \frac{V}{R}$ (substitute in equation 2)
 $P = \frac{V}{R} \times V$

$$\boxed{P = \frac{V^2}{R}}$$

EXAMPLES:

1. How much energy is consumed by a 0.5kW electrical kettle in 30 minutes?

$P = 0.5kW = 0.5 \times 1000$	$W = VIt$
$P = 500W$	<i>but</i> $P = IV = 500W$
$t = 30\ mins = 30 \times 60$	$W = 500 \times 1800$
$t = 1800s$	$W = 900,000J$

2. How much energy is consumed by a 60W lamp in 10 hours?

$P = 60W$	$W = VIt$
$t = 10\ hours = 10 \times 3600$	<i>but</i> $P = IV = 60W$
$t = 36000s$	$W = 60 \times 36000$
	$W = 2,160,000J$

CALCULATIONS IN ELECTRICAL CIRCUITS
Steps and tips taken;

- Find the total or effective resistance in the circuit.
- When finding current through a resistor in parallel, first find the potential difference (voltage) across the parallel connection.
- Power dissipated in any resistor is $P = I^2 R$
- Power expended in the whole circuit is $P = I^2(R + r)$ where R is effective resistance.

EXAMPLES:

1. In the diagram below, a battery of emf 12V and internal resistance 0.6Ω is connected to 3 resistors.

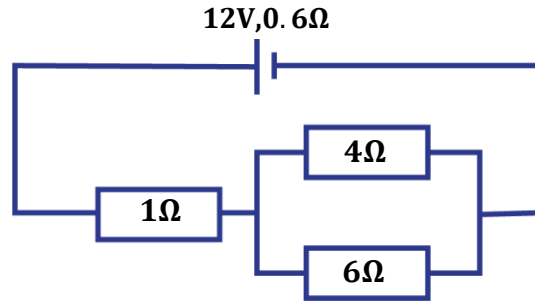

Calculate;

- (i) Current through the circuit.
- (ii) Current through the 4Ω and 6Ω resistor.
- (iii) Power dissipated in the 4Ω resistor.
- (iv) Power expended in the circuit.

$$E = 12V \quad r = 0.6\Omega$$

effective resistance

$$\text{In parallel, } R_p = \frac{R_1 R_2}{R_1 + R_2}$$

$$R_p = \frac{4 \times 6}{4 + 6}$$

$$R_p = 2.4\Omega$$

$$\text{thus } R = 1 + R_p$$

$$R = 1 + 2.4$$

$$R = 3.4\Omega$$

(i)

current through the circuit

$$E = I(R + r)$$

$$12 = I(3.4 + 0.6)$$

$$12 = I \times 4$$

$$I = \frac{12}{4}$$

$$I = 3A$$

(iii)

power dissipated in 4Ω resistor

$$P = I^2 R$$

$$P = 1.8^2 \times 4$$

$$P = 12.96W$$

(ii)

p.d across parallel connection

$$V = IR_p$$

$$V = 3 \times 2.4$$

$$V = 7.2V$$

current through 4Ω resistor

from $V = IR$

$$7.2 = I \times 4$$

$$I = \frac{7.2}{4}$$

$$I = 1.8A$$

current through 6Ω resistor

from $V = IR$

$$7.2 = I \times 6$$

$$I = \frac{7.2}{6}$$

$$I = 1.2A$$

(iv)

power dissipated in 4Ω resistor

$$P = I^2(R + r)$$

$$P = 3^2 \times (3.4 + 0.6)$$

$$P = 9 \times 4$$

$$P = 36W$$

2. In the diagram below, two cells of emf 1.5V and internal resistance of 1Ω each are connected to a network of resistors.

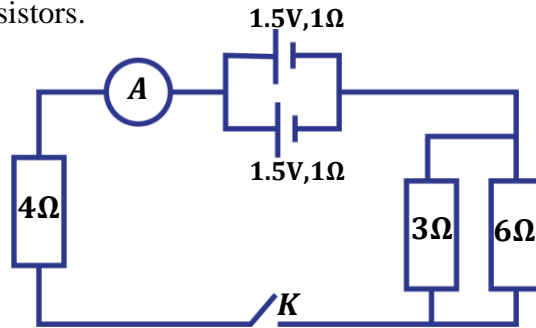

- (i) What will be the ammeter reading when switch K is closed?
(ii) Calculate the current through the 3Ω resistor.
(iii) Calculate power dissipated in 3Ω resistor.
(iv) Calculate power developed in 4Ω resistor.

total emf, $E = 1.5V$ (cells in parallel)

total internal resistance, $r = \frac{r_1 r_2}{r_1 + r_2}$

$$r = \frac{1 \times 1}{1 + 1} = 0.5\Omega$$

effective resistance

In parallel, $R_p = \frac{R_1 R_2}{R_1 + R_2}$

$$R_p = \frac{3 \times 6}{3 + 6}$$

$$R_p = 2\Omega$$

thus $R = 4 + R_p$

$$R = 4 + 2$$

$$R = 6\Omega$$

(i)

current through the circuit

$$E = I(R + r)$$

$$1.5 = I(6 + 0.5)$$

$$1.5 = I \times 6.5$$

$$I = \frac{1.5}{6.5}$$

$$I = 0.23A$$

The ammeter reading will be **0.23A**.

(ii)

p. d across parallel connection

$$V = IR_p$$

$$V = 0.23 \times 2$$

$$V = 0.46V$$

current through 3Ω resistor

from $V = IR$

$$0.46 = I \times 3$$

$$I = \frac{0.46}{3}$$

$$I = 0.15A$$

(iii)

power dissipated in 3Ω resistor

$$P = I^2 R$$

$$P = 0.15^2 \times 3$$

$$P = 0.068W$$

(iv)

power developed in 4Ω resistor

Since it is in series, the current passing through it is the current through the whole circuit.

$$P = I^2 R$$

$$P = 0.23^2 \times 4$$

$$P = 0.212W$$

3. A battery of emf 2V and negligible internal resistance is connected as shown below. Find the ammeter reading.

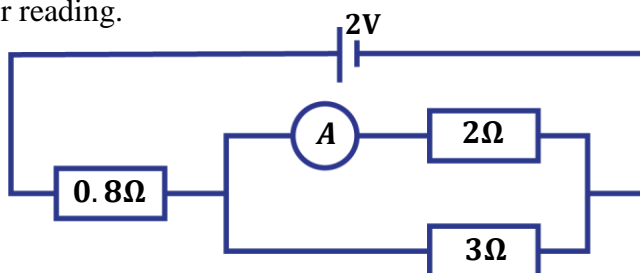

$$E = 2V \quad r = 0\Omega$$

effective resistance

$$\text{In parallel, } R_p = \frac{R_1 R_2}{R_1 + R_2}$$

$$R_p = \frac{2 \times 3}{2 + 3}$$

$$R_p = 1.2\Omega$$

$$\text{thus } R = 0.8 + R_p$$

$$R = 0.8 + 1.2$$

$$R = 2\Omega$$

current through the circuit

$$E = I(R + r)$$

$$2 = I(2 + 0)$$

$$2 = I \times 2$$

$$I = \frac{2}{2}$$

$$I = 1A$$

The ammeter is reading the current through the 2Ω.

p.d across parallel connection

$$V = IR_p$$

$$V = 1 \times 1.2$$

$$V = 1.2V$$

current through 2Ω resistor

from $V = IR$

$$1.2 = I \times 2$$

$$I = \frac{1.2}{2}$$

$$I = 0.6A$$

The ammeter reading is **0.6A**

4. A battery of emf 10V and internal resistance 1.0Ω is connected to a system of resistors as shown below.

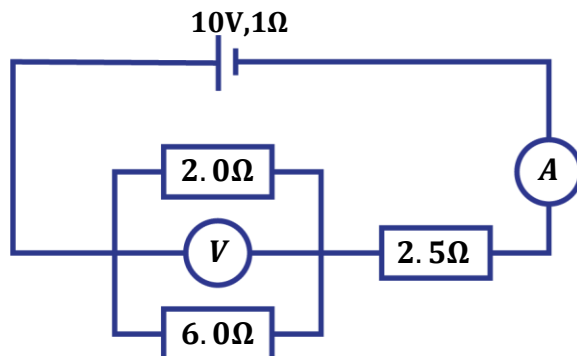

- Calculate the ammeter and voltmeter readings.
- Find the current through the 2Ω resistor.
- Find the power dissipated in 2Ω resistor.
- Find also the total power expended in the circuit.

$$E = 10V \quad r = 1\Omega$$

effective resistance

$$\text{In parallel, } R_p = \frac{R_1 R_2}{R_1 + R_2}$$

$$R_p = \frac{2 \times 6}{2 + 6}$$

$$R_p = 1.5\Omega$$

$$\text{thus } R = 2.5 + R_p$$

$$R = 2.5 + 1.5$$

$$R = 4\Omega$$

(i)

current through the circuit

Since the ammeter is in series with the battery, it reads the total current through the whole circuit.

$$E = I(R + r)$$

$$10 = I(4 + 1)$$

$$10 = I \times 5$$

$$I = \frac{10}{5}$$

$$I = 2A$$

The ammeter reading is 2A

p.d across parallel connection

Since the voltmeter is connected across the resistors in parallel, it is reading the p.d across the parallel connection.

$$V = IR_p$$

$$V = 2 \times 1.5$$

$$V = 3V$$

The voltmeter reading is 3V.

(ii)

current through 2Ω resistor

from $V = IR$

$$3 = I \times 2$$

$$I = \frac{3}{2}$$

$$I = 1.5A$$

(iii)

power dissipated in 2Ω resistor

$$P = I^2 R$$

$$P = 1.5^2 \times 2$$

$$P = 4.5W$$

(iv)

total power expended in circuit

$$P = I^2 (R + r)$$

$$P = 2^2 \times (4 + 1)$$

$$P = 20W$$

5. Three resistors are connected as shown in the circuit diagram below.

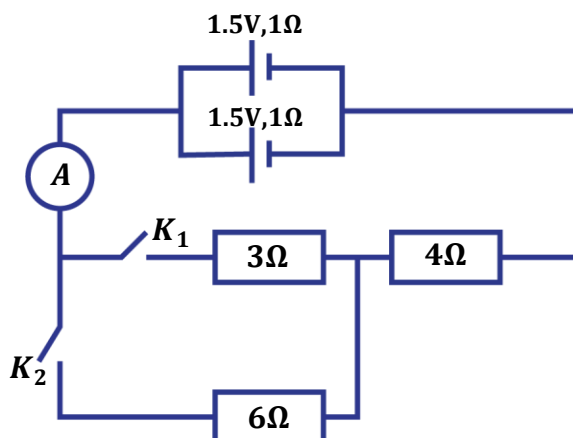

Calculate;

- (i) The ammeter reading when K_1 and K_2 are closed.
- (ii) The ammeter reading only if K_1 is closed.

total emf, $E = 1.5V$ (cells in parallel)

total internal resistance, $r = \frac{r_1 r_2}{r_1 + r_2}$

$$r = \frac{1 \times 1}{1 + 1} = 0.5\Omega$$

(i)

when switches K_1 and K_2 are closed, current flows through all the resistors

effective resistance

In parallel, $R_p = \frac{R_1 R_2}{R_1 + R_2}$

$$R_p = \frac{3 \times 6}{3 + 6}$$

$$R_p = 2\Omega$$

thus $R = 4 + R_p$

$$R = 4 + 2$$

$$R = 6\Omega$$

current through the circuit

$$E = I(R + r)$$

$$1.5 = I(6 + 0.5)$$

$$1.5 = I \times 6.5$$

$$I = \frac{1.5}{6.5}$$

$$I = 0.23A$$

The ammeter reads **0.23A**.

(ii)

when only switch only K_1 is closed, current only flows through the 3Ω and 2Ω resistors

effective resistance

$$R = 3 + 4$$

$$R = 7\Omega$$

current through the circuit

$$E = I(R + r)$$

$$1.5 = I(7 + 0.5)$$

$$1.5 = I \times 7.5$$

$$I = \frac{1.5}{7.5}$$

$$I = 0.2A$$

The ammeter reads **0.2A**.

6.

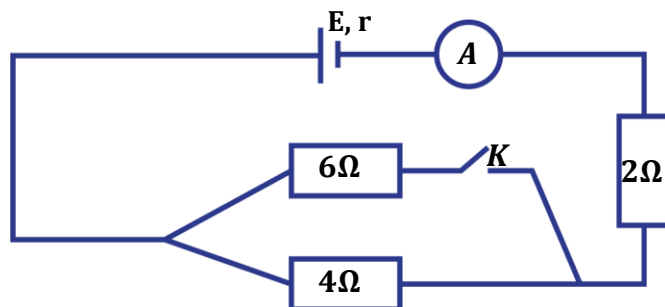

In the diagram above, when the switch is open the ammeter reads 2A and when its closed, the ammeter reads 2.64A. Calculate;

- Explain what happens when the switch is left open and then closed.
- The emf E and internal resistance of the battery.
- Rate at which electrical energy is converted to when the switch is open.
- Lost voltage (potential drop) when the switch is open.

(i)

When the switch is left open, current from the battery flows only through the 4Ω and 2Ω resistors and the 6Ω resistor is left out since its circuit is not complete.

When the switch is closed, current flows through all the resistors.

(ii)

when the switch is open

Current only flows through 4Ω and 2Ω resistors and they are in series

$$I = 2A$$

effective resistance

$$R = 4 + 2$$

$$R = 6\Omega$$

current through the circuit

$$E = I(R + r)$$

$$E = 2(6 + r)$$

$$E = 12 + 2r$$

$$E - 2r = 12 \text{ --- (1)}$$

when the switch is closed

Current only flows through all the resistors and

$$I = 2.64A$$

effective resistance

$$R = \frac{R_1 R_2}{R_1 + R_2} + R_3$$

$$R = \frac{6 \times 4}{6 + 4} + 2$$

$$R = 2.4 + 2$$

$$R = 4.4\Omega$$

current through the circuit

$$E = I(R + r)$$

$$E = 2.64(4.4 + r)$$

$$E = 11.616 + 2.64r$$

$$E - 2.64r = 11.616 \text{ --- (2)}$$

Solving equations 1 and 2 simultaneously.

$$E - 2r = 12$$

$$- \underline{E - 2.64r = 11.616}$$

$$0 + 0.64r = 0.384$$

$$r = \frac{0.384}{0.64}$$

$$r = 0.6\Omega$$

from equation 1, $E - 2r = 12$

$$E = 12 + 2r$$

$$E = 12 + 2 \times 0.6$$

$$E = 12 + 1.2$$

$$E = 13.2V$$

(iii)

total power or rate at which work is done

$$P = I^2(R + r)$$

$$P = 2^2 \times (6 + 0.6)$$

$$P = 26.4W$$

(iv)

$$\text{voltage drop} = Ir$$

$$\text{voltage drop} = 2 \times 0.6$$

$$\text{voltage drop} = 1.2V$$

7. The battery X has an internal resistance of 0.2Ω . When its connected in the circuit below, the ammeter reads $0.2A$.

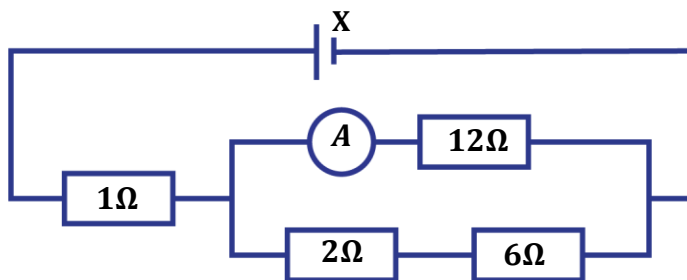

Calculate;

- (i) Current through 2Ω resistor.
- (ii) Emf X of the battery.

(i)

p.d across parallel connection

This p.d is the same as p.d across the 12Ω resistor.

ammeter reading $I_1 = 0.2A$

$$V = I_1 R$$

$$V = 0.2 \times 12$$

$$V = 2.4V$$

total resistance in series

$$R_s = 2 + 6$$

$$R_s = 8\Omega$$

current through 2Ω

$$V = I_1 R$$

$$2.4 = I_1 \times 8$$

$$I_1 = \frac{2.4}{8}$$

$$I_1 = 0.3A$$

(ii)

total current in the circuit

$$I = I_1 + I_2$$

$$I = 0.2 + 0.3$$

$$I = 0.5A$$

effective resistance in the circuit

$$R = \frac{R_s \times R_2}{R_s + R_2} + R_3$$

$$R = \frac{8 \times 12}{8 + 12} + 1$$

$$R = 4.8 + 1$$

$$R = 5.8\Omega$$

(iii)

$$r = 0.2\Omega$$

$$E = I(R + r)$$

$$E = 0.5(5.8 + 0.2)$$

$$E = 0.5 \times 6$$

$$E = 3V$$

EXERCISE:

1. In the diagram below, what will be the voltmeter reading when switch K is closed?

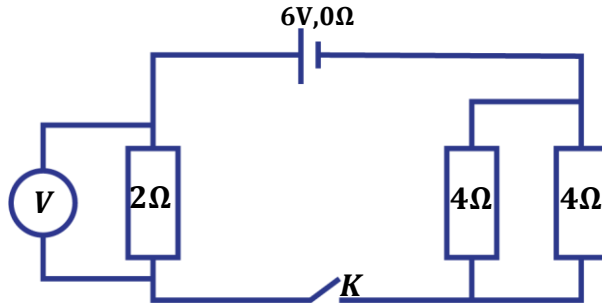

2. In the diagram below, a battery of emf 12V and negligible internal resistance is connected across resistors as shown below.

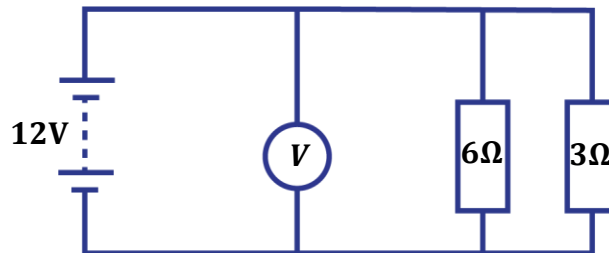

Calculate;

- Current through the circuit.
- Voltmeter reading.
- Current through the 6Ω resistor.
- Total power expended in the circuit.

3. An accumulator of 24V and internal resistance 2Ω is connected as shown below.



Calculate;

- Lost voltage.
 - Current through the 6Ω resistor.
 - Power dissipated in the 6Ω resistor.
 - Total power expended in the circuit
4. A dry cell of emf, E and internal resistance, r drives a current of $0.25A$ through a resistor of 5.5Ω and also drives a current of $0.3A$ through a resistor of 4.5Ω as shown in the figures. Determine the emf, E and internal resistance, r .



5. A dry cell of emf, E is connected in the circuit as shown below.

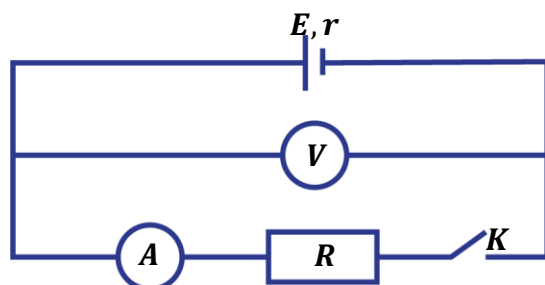

When switch K is open, the voltmeter reading is $1.4V$. When the switch K is closed, the ammeter reading is $1.0A$ and the voltmeter reading is $0.9V$.

- Write an expression relating E , ammeter reading, I , voltmeter reading, V , and internal resistance, r of the cell.
- Calculate the internal resistance of the cell.
- Find the value of the resistance, R .

COMMERCIAL ELECTRICITY

In Uganda, electricity is sold by electricity boards such as UMEME. They use our meters to estimate the electrical energy consumed. The energy consumed is measured in kilowatt hours (kWh).

Definition:

A **kilowatt hour** is the amount of electrical energy consumed by a device of power 1000W in one hour.

$$1kWh = 1kW \times 1hour$$

$$1kWh = 1000W \times 3600s$$

$$1kWh = 3,600,000Ws$$

$$1kWh = 3,600,000J$$

Calculations for cost of electricity:

Number of units of electricity = Power (kilo Watts) \times time (hours)

$$\text{Number of units of electricity} = P \text{ (kW)} \times t \text{ (hrs)}$$

Total cost of electricity = Power (kilo Watts) \times time (hours) \times unit cost

$$\text{Total cost of electricity} = P \text{ (kW)} \times t \text{ (hrs)} \times \text{unit cost}$$

NOTE:

All electrical appliances are marked (rated) showing the power rating in Watts and voltage in Volts. E.g.

An electrical appliance rated 240V, 60W means that the appliance supplies or consumes 60J every second when connected to a 240V mains supply.

EXAMPLES:

- How much will it cost to run four bulbs rated at 40W each for 2 days, if the cost of each unit of electricity is shs. 30.?

$$P = 4 \times 40 = 160W$$

$$\text{In kW, } P = \frac{160}{1000} = 0.16kW$$

$$t = 2\text{days} = 2 \times 24 = 48 \text{ hours}$$

$$\text{unit cost} = 30 \text{ shs}$$

$$\text{cost of electricity} = \text{Power(kW)} \times t(\text{hours}) \times \text{unit cost}$$

$$\text{cost of electricity} = 0.16 \times 48 \times 30$$

$$\text{cost of electricity} = 230.4 \text{ shs}$$

- Find the cost to run two bulbs rated at 60W each and an electric iron rated at 120W for 35 minutes, if the unit is 415 shs.

<u>for bulbs</u>		<u>for electric iron</u>
$P = 2 \times 60 = 120W$		$P = 120W$
$\text{Total power, } P = 120 + 120 = 240W$		

$$\text{In kW, } P = \frac{240}{1000} = 0.24kW$$

$$t = 35 \text{ mins} = \frac{35}{60} \text{ hours}$$

$$\text{unit cost} = 415 \text{ shs}$$

$$\text{cost of electricity} = \text{Power(kW)} \times t(\text{hours}) \times \text{unit cost}$$

$$\text{cost of electricity} = 0.24 \times \frac{35}{60} \times 415$$

$$\text{cost of electricity} = 58.1 \text{ shs}$$

3. An electrical heater is rated at 3000W, 240V.
- What is meant by the statement.
 - Calculate;
 - Current and resistance of the heater.
 - Total number of units it consumes in $1\frac{1}{2}$ hours.
 - The cost of electricity if each unit costs 9,000 shs after using the heater for 3 hours every day for 10 days.

(a) An electrical heater supplies or consumes 3000J every second when connected to a 240V mains supply.

(b) (i) Given $P = 3000W$, $V = 240V$

$$P = IV$$

$$3000 = I \times 240$$

$$I = \frac{3000}{240}$$

$$I = 12.5A$$

$$V = IR$$

$$240 = 12.5 \times R$$

$$R = \frac{240}{12.5}$$

$$R = 19.2\Omega$$

OR

$$P = I^2R$$

$$3000 = 12.5^2 \times R$$

$$R = \frac{3000}{12.5^2}$$

$$R = 19.2\Omega$$

(ii)

$$\text{number of units} = \text{Power(kW)} \times t(\text{hours})$$

$$\text{number of units} = \frac{3000}{1000} \times 1\frac{1}{2}$$

$$\text{number of units} = 3 \times \frac{3}{2}$$

$$\text{number of units} = 4.5\text{kWh}$$

(iii)

$$\text{cost of electricity} = \text{Power(kW)} \times t(\text{hours}) \times \text{unit cost}$$

$$\text{cost of electricity} = \left(\frac{3000}{1000}\right) \times (3 \times 10) \times 9000$$

$$\text{cost of electricity} = 810,000 \text{ shs}$$

4. Jane paid an electricity bill of 1800shs after using two identical bulbs for 2 hours every day for 10 days at a cost of 600shs per unit. Determine the power consumption by each of the bulbs.

$$\text{total cost of electricity} = \text{Power(kW)} \times t(\text{hours}) \times \text{unit cost}$$

$$1800 = P(\text{kW}) \times (2 \times 10) \times 600$$

$$1800 = P(\text{kW}) \times 12000$$

$$P(\text{kW}) = \frac{1800}{12000}$$

$$P(kW) = 0.15kW$$

$$\text{for each bulb } P = \frac{0.15}{2} = 0.075kW = 75W$$

Therefore, each bulb consumes power of **75W**.

EXERCISE:

- Find the cost of running five 60W lamps and four 100W lamps for 8 hours if the electrical energy costs 5shs per unit.
- Mr. Ssekwe uses 3 kettles of 800W each, a flat iron of 1000W, 3 bulbs of 60W each and 4 bulbs of 75W each. If they are used for 3hours every day for 30 days and one unit of electricity costs 200shs, find the total cost of running the appliances.
- A television is rated 240V, 60W.
 - What do you understand by the statement above.
 - Calculate the current flowing through the TV.
 - Calculate the resistance of the television.
 - Calculate the cost of running the television for 600 minutes if the unit cost is 60shs.

GENERATION AND TRANSMISSION OF ELECTRICITY

(a) Generation of electricity:

Electricity is generated at power stations by using coal, nuclear reactions, wind, sun, running water etc.

(b) Transmission of electricity:

Electricity generated at power stations is stepped up to higher voltages before transmission using step transformers.

The power transmitted is usually alternating current and it is stepped down as it reaches factories, industries, towns and homes using step down transformers.

Transmission can either be overhead or underground.

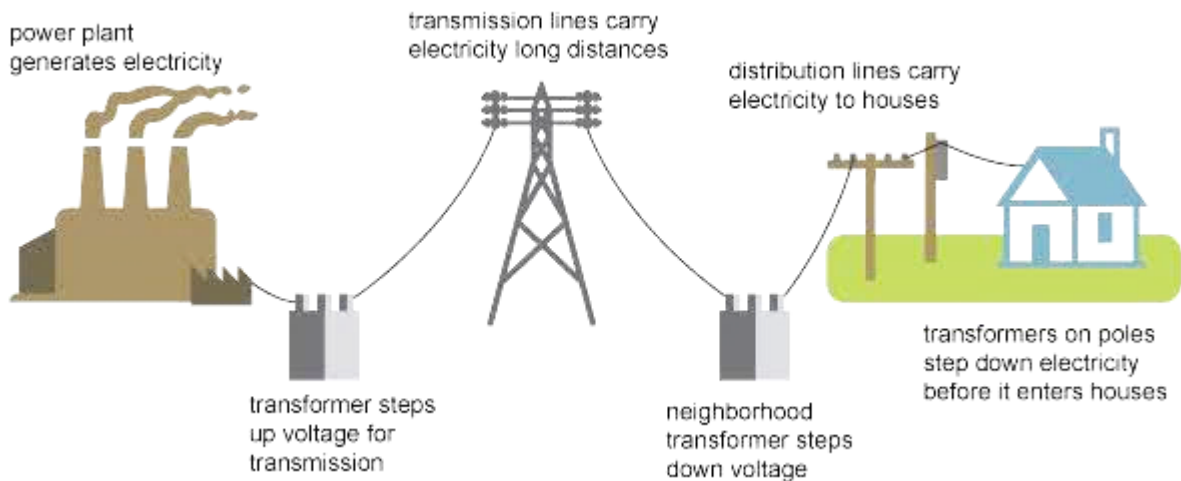

How power losses are reduced during transmission of electricity:

- Electricity is transmitted at high voltages to reduce power loss due to the heating effect in the transmission cables.
- The transmission cables are made thick to reduce its resistance hence minimizing power loss.



(c) House wiring (domestic electrical installation):

Electricity is connected in a house by thick cables called the **mains** from the electricity poles to the meter box or fuse box and then to the main distribution box. From here electricity is supplied to the electrical appliances.

The electricity supply cables in a house consist of the following wires.

TYPE OF WIRE	COLOUR	USE
Live wire	Red or brown	It carries current to the appliance.
Neutral wire	Blue or black	It completes the circuit. Thus, it carries current away from the source.
Earth wire	Yellow or green or yellow with green stripes	It is connected to the metal case of an appliance to provide an alternative path for stray current in case the appliance becomes live.

When wiring a house, the following should be included in the circuits.

DEVICE NAME	CONNECTION AND USE
(i) Switch 	<ul style="list-style-type: none"> ▪ It controls the flow of current in the circuit. ▪ It is connected to the live wire such that it cut off and switch on current whenever needed.
(ii) Fuse 	<ul style="list-style-type: none"> ▪ It contains a thin wire of a very low melting point. ▪ The thin wire melts whenever current exceeds the rated value. ▪ It is connected to the live wire.
(iii) Sockets 	<ul style="list-style-type: none"> ▪ These are power points usually put on the walls. ▪ They have three holes leading to the live wire, neutral wire and the earth wire.

Precautions taken when wiring a house:

- The right colour codes must be followed i.e. red for live wire, black for neutral wire and yellow for earth wire.
- All switches should be connected to the live wire.
- Wires should be insulated.
- Keep hands dry when dealing with electricity.
- Earthing should always be done to prevent electrical shocks in case an appliance gets a fault.

LIGHT CIRCUITS

Electrical appliances e.g. bulbs and lamps are usually connected in parallel with the mains supply. The switches of these lamps are connected to the live wire. The neutral wire completes the circuit.

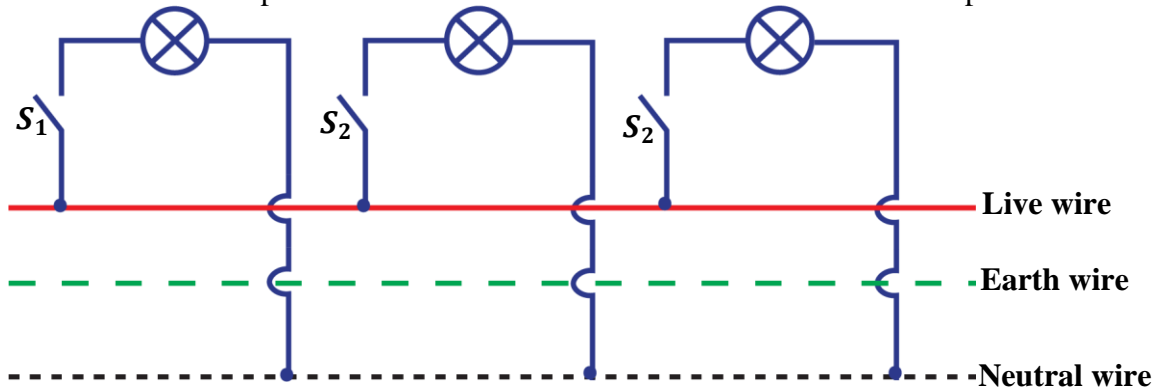
Advantages of connecting lamps in parallel:

- Lamps have the same voltage as the source.
- If one lamp gets a fault, the other lamps continue working.
- It enables switching on and off of the lamps independently (i.e. each lamp can have its own switch.)

Example:

The diagram below is a circuit connection

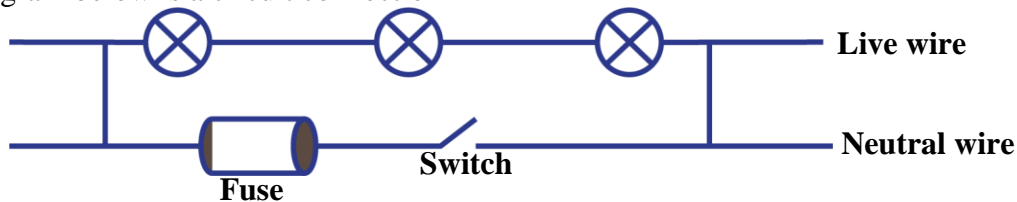

Identify the wrong corrections in the circuit.

- Bulbs were connected in series yet they have to be connected in parallel.
- Fuse was connected to the neutral wire yet it is supposed to be connected on the live wire.
- The switch was connected to the neutral wire yet it is supposed to be connected on the live wire.

FILAMENT LAMPS (INCANDESCENT LAMPS)

These are lamps that produce light by heating a filament to a high temperature.

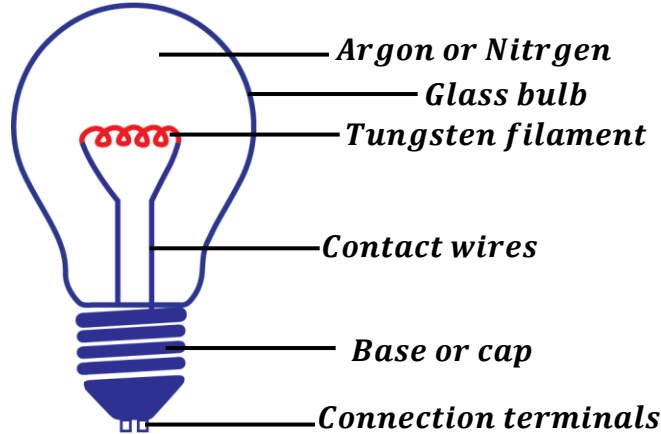

Mode of operation of a filament lamp:

When switched on, the coiled tungsten filament is heated and it becomes white hot thus emitting light.

The higher the temperature of the filament, the greater the light given off.

Note:

- The filament is made of tungsten because tungsten has a high melting point. Therefore, it can't melt easily when heated to very high temperatures.
- The filament is coiled to reduce the space it occupies in the glass bulb thus reducing heat through convection.
- The glass bulb contains inert gases (i.e. Argon/Nitrogen) at low pressure to reduce evaporation of the filament otherwise it would condense on the bulb and blacken it.

FLUORESCENT LAMPS (DISCHARGE LAMPS)

Fluorescent tube is a gas discharge lamp that uses electricity to energize or excite mercury vapour. It has electrodes at the ends and the inside wall is coated with fluorescent substance e.g. phosphor.

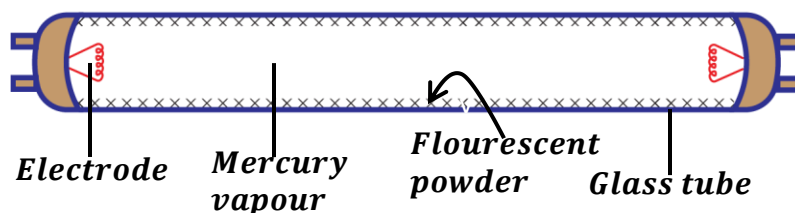

When switched on, mercury vapour is excited/energized and it emits ultra-violet radiations. The radiations strike the fluorescent substance causing it to produce visible light.

NB: Fluorescent substance is a substance that gives off light when radiations fall on it.

Advantages of fluorescent tubes/lamps over filament lamps:

- They are long lasting.
- They don't produce much heat.
- They consume less power.

Disadvantages of fluorescent lamps:

- They are expensive.
- They require high installation costs.
- They may not start when the supply voltage is low.

MOTION IN FLUIDS

A fluid is a substance which can flow e.g. liquids and gases.

When a body falls through a fluid, it will be acted upon by the following forces.

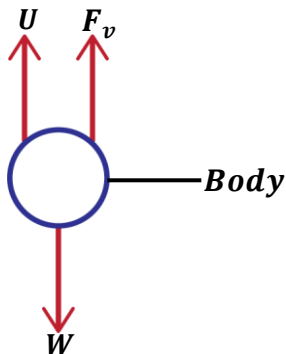

- ❖ Upthrust (U) acting upwards.
- ❖ Viscous drag or Viscous force (F_v) acting upwards.
- ❖ Weight of the body (W) acting downwards.

Upthrust (Buoyancy):

This is the upward force that a fluid exerts on a body falling through it.

For example;

- When pushing a jerrycan into water, our fingers experience an upward force.
- A balloon filled with air or hydrogen rises up due to upthrust.

Viscous drag (Viscous force):

This the force that opposes motion of a body in a fluid.

Viscous drag increases with an increase in velocity or speed of the body in a body.

Describing motion of a body falling in a viscous fluid (e.g. oil)

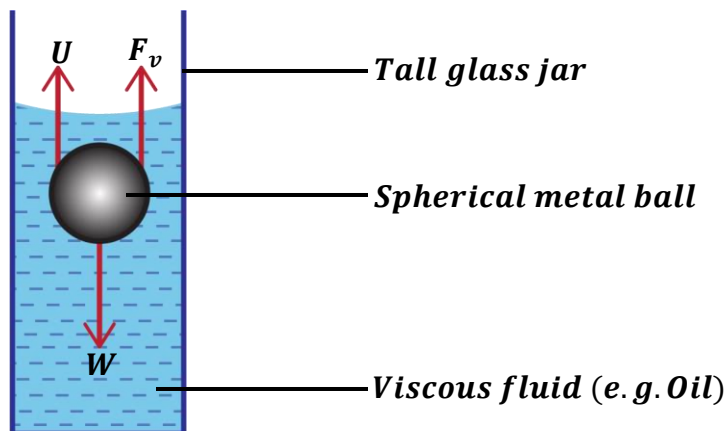

When the ball falls through a fluid, it first accelerates downwards until it attains a constant velocity called **terminal velocity**. At this velocity, the weight of the ball is equal to sum of upthrust and viscous drag.

$$i.e. \text{ Weight} = \text{Upthrust} + \text{Viscous drag}$$

$$W = U + F_v$$

The ball continues with this constant velocity until it hits the bottom of the tall glass jar.

NOTE:

As the body accelerates downwards, the viscous drag continues to increase with the increasing velocity and eventually the body can no longer accelerate. Therefore, it has a constant velocity.

Terminal velocity:

This is a constant velocity attained by the body falling in a fluid when the resultant force on the body is zero.

i.e. when upward forces (viscous drag and upthrust) = downward forces (weight of the body).

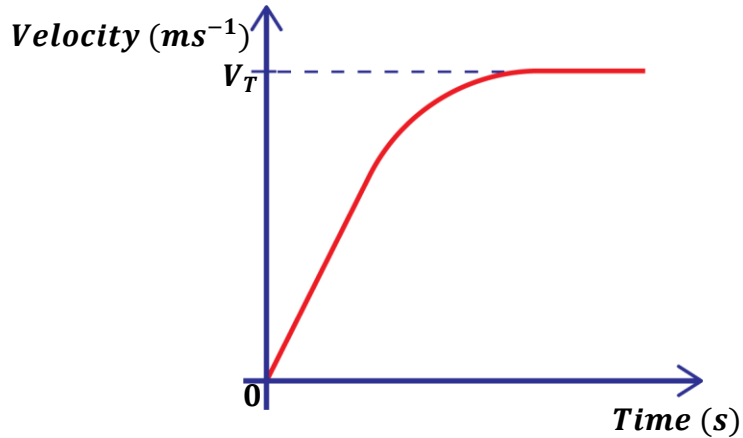
Velocity-time graph for a body falling in a fluid

V_T – Terminal velocity

Note: In case the object is moving in air (e.g. a balloon floating in air), the viscous drag is composed of the air resistance.

Question:

Explain what happens to a parachutist diving from an aero plane.

- *At first, the parachutist accelerates downwards as he/she begins to fall.*
- *As the parachutist's velocity (speed) increases, the viscous drag also increases until the parachutist is unable to accelerate any more. At this point the parachutist attains a constant velocity called terminal velocity.*
- *At terminal velocity, weight of the parachutist is equal to the upthrust and viscous drag. Therefore, the resultant force on the parachutist is zero.*

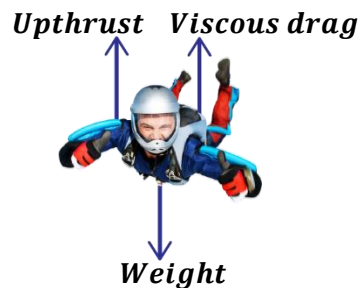

FLUID FLOW

Fluid flow describes how fluids move and how they behave and interact with the surrounding environment. The flow of a liquid may either be steady (orderly) or unsteady (unorderly).

Flow of a fluid depends on three factors namely;

- Characteristics of the fluid (i.e. density, compressibility and viscosity)
- Speed or velocity of flow.
- Shape of surface on which the fluid is flowing.

Types of fluid flow:

There are two types of fluid flow namely;

- Streamline flow (Laminar flow).
- Turbulent flow.

STREAMLINE FLOW (LAMINAR FLOW):

Streamline flow is the type of fluid flow where all the fluid particles that pass any point follow the same path at the same velocity (uniform velocity).

In streamline flow, the fluid particles move or travel in the same direction and with the same speed.

Therefore, streamline flow is a steady, orderly and uniform flow of a fluid.

Streamline flow occurs when the fluid is moving at a low speed.

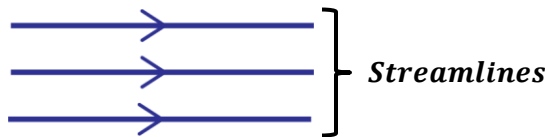

Definition:

A **streamline** is a line showing particles of a fluid having streamline flow.

TURBULENT FLOW:

Turbulent flow is the type of fluid flow where the speed (velocity) and the direction of fluid particles passing any point vary with time.

In turbulent flow, the fluid particles travel in different directions with different speeds.

Therefore, turbulent flow is an unsteady, disorderly and non-uniform flow of the fluid.

Turbulent flow occurs when the fluid is moving with a high speed.

Practical example:

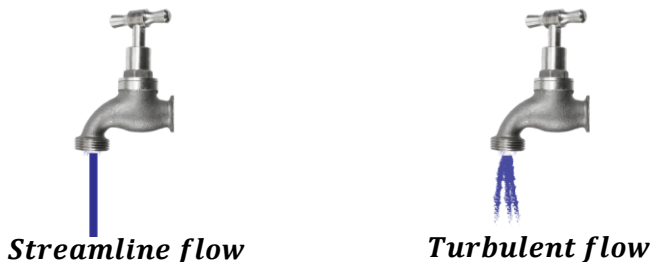

When a tap is opened slightly, the water flows out slowly in form of a thin smooth orderly stream. At this point, the type of fluid flow is streamline flow.

As the tap is opened further, the water flows out fast in a disorderly way. At this point, the type of fluid flow is turbulent flow.

BERNOULLI'S PRINCIPLE

Bernoulli's principle states that when the speed of a moving fluid increases, the pressure in the fluid decreases and vice versa.

This relationship between speed and pressure was formulated by a scientist called **Daniel Bernoulli**.

Rate of flow of a fluid:

This is the volume of the fluid that passes a point of a tube in a given time.

$$\text{Rate of fluid flow} = \frac{\text{Volume of fluid}}{\text{Time}}$$

$$\text{Rate of fluid flow} = \frac{\text{Cross sectional Area of tube} \times \text{distance moved by fluid}}{\text{Time}}$$

$$\text{Rate of fluid flow} = \frac{A \times d}{t}$$

But speed, $v = \frac{d}{t}$

$$\text{Rate of fluid flow} = A \times v$$

Therefore, **Rate of fluid flow = Av**

where A – Cross sectional area.

v – Velocity or speed of the fluid.

NOTE:

- ❖ The rate of flow at any section of the pipe is the same.
- ❖ In streamline flow of a fluid, the larger the pipe, the lower speed of the fluid and vice versa

Examples:

1. Water flows in through a horizontal pipe of cross-sectional area 0.01m^2 . At the outlet section, the cross-sectional area is 0.005m^2 . If the velocity of water at the larger cross-section is 1.25ms^{-1} , find;

- i) rate of flow of water in the larger pipe.
- ii) Speed of water in the smaller pipe,

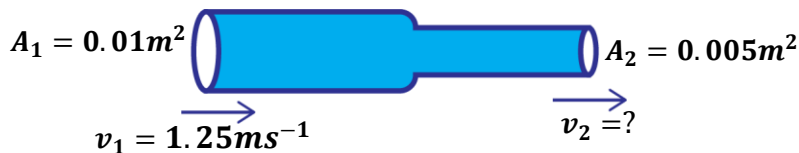

i)

$$\begin{aligned} \text{Rate of flow} &= A_1 v_1 \\ \text{Rate of flow} &= 0.01 \times 1.25 \\ \text{Rate of flow} &= 0.0125\text{m}^3\text{s}^{-1} \end{aligned}$$

ii)

$$\begin{aligned} \text{Rate of flow} &= A_2 v_2 \\ 0.0125 &= 0.005 \times v_2 \\ v_2 &= \frac{0.0125}{0.005} \\ v_2 &= 2.5\text{ms}^{-1} \end{aligned}$$

2. Water flows through a horizontal pipe of varying cross-section area as shown in the figure below. the velocity of water in pipe **A** is 2m/s . Determine the velocity of water in pipe **B**.

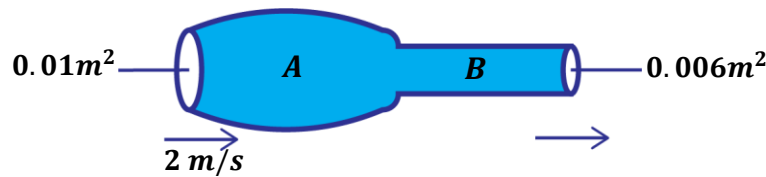

since the rate of flow is the same through the pipe;

Rate of flow in A = Rate of flow in B

$$A_1 v_1 = A_2 v_2$$

$$0.01 \times 2 = 0.006 \times v_2$$

$$v_2 = \frac{0.01 \times 2}{0.006}$$

$$v_2 = 3.33\text{m/s}$$

Demonstrating Bernoulli's principle in liquids

Consider a liquid flowing through a horizontal uniform tube from left to right as shown below.

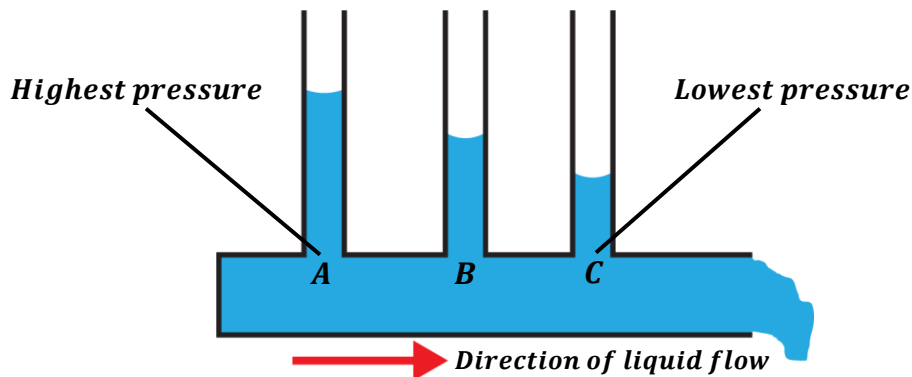

Height of the liquid in the tube goes on decreasing as water flow. This indicates that the liquid pressure decreases from left to right.

This explains that liquids flow from places with higher pressure to place with lower pressure.

However, if a venturi tube (non-uniform tube) is used where the diameter at **B** is made smaller than **A** and **C**, the liquid level become lowest at **B** and water level rises again at **C**.

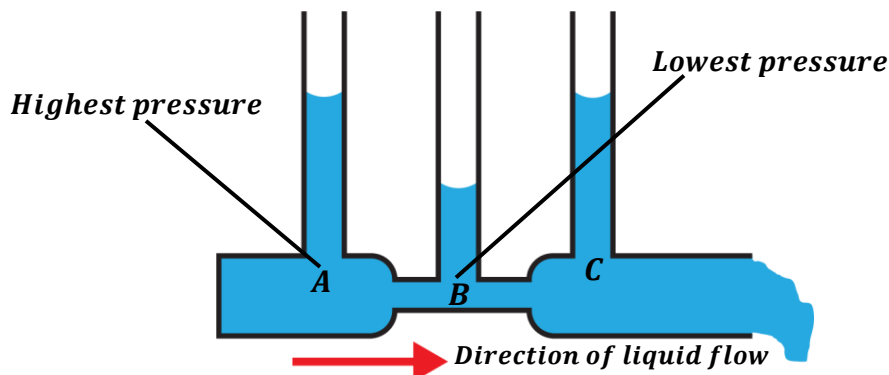

The liquid level falls at B indicating a decrease in pressure.

This is because the liquid flows fastest at B and according to Bernoulli's principle, the faster the liquid flow, the lower the liquid pressure.

Demonstrating Bernoulli's principle in gases

- When air is blown between two sheets of paper;

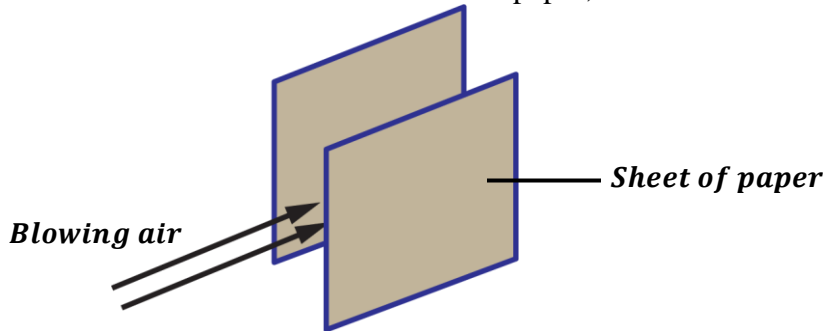

Observation: The two sheets come together.

Explanation: When air is blown between them, the air molecules move faster resulting to a decrease in pressure in between. Therefore, the external pressure out exceeds the inside pressure and forces the sheets to come closer.

- When air is blown between two balloons filled with a gas;

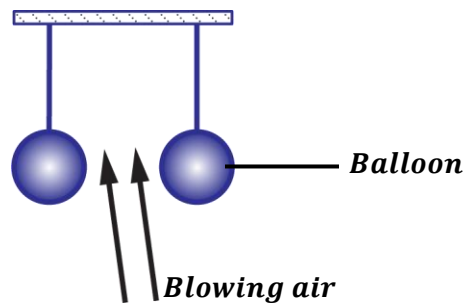

Observation: The two balloons come together.

Explanation: When air is blown between them, the air molecules move faster resulting to a decrease in pressure in between. Therefore, the external pressure out exceeds the inside pressure and forces the balloons to come closer.

- When air is blown below a paper placed on two wooden blocks.;

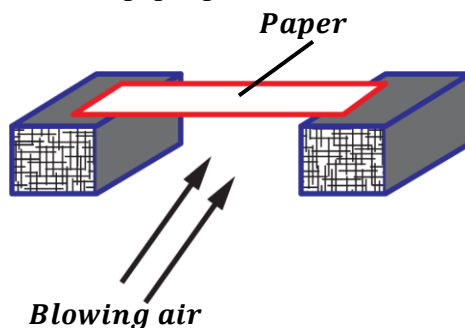

Observation: The paper curves upwards.

Explanation: When air is blown below the paper, the air molecules under the paper move faster resulting to a decrease in pressure. Therefore, the external pressure on top of the paper exceeds the the pressure below and forces the paper down thus curving upwards.

APPLICATIONS OF BERNOULLI'S PRINCIPLE

Bernoulli's principle is applied in:

Spray guns:

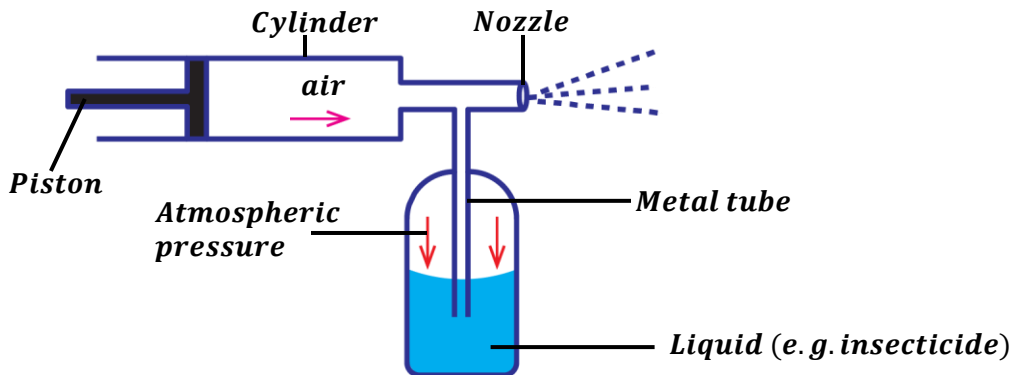

- When the piston is pushed in, it forces the air in the cylinder to move with a high velocity through the nozzle.
- The movement of air with a high velocity causes a decrease in pressure inside the cylinder.
- Since the pressure in the cylinder is less than the pressure acting on the liquid (atmospheric pressure), the atmospheric pressure forces the liquid to rise through the metal tube.
- The rising liquid is sprayed out through the nozzle.

Bunsen burner:

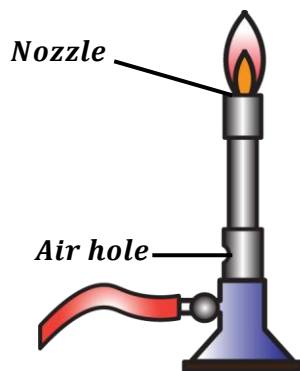

- When a Bunsen burner is connected to a gas supply, the gas is made to move with a high velocity inside the burner through the nozzle. This creates a region of low pressure inside the burner.
- Since the atmospheric pressure outside the burner is now more than the pressure inside, it forces air from outside atmosphere to enter in the burner and mixes with the gas.
- The mixture of air and gas enables the gas to burn completely and produce a clean, hot and smokeless flame.

Aero foil:

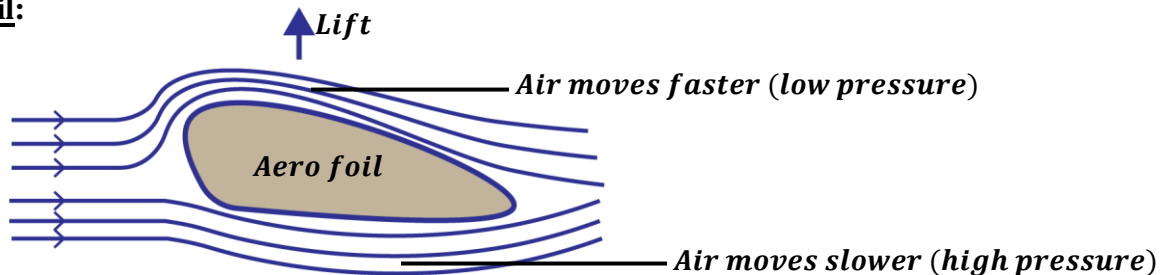

- The wing of an aero plane is the form of an aero foil i.e. the upper surface is curved and the surface below is flat. This makes the air passing over the top of the wing to move a longer distance thus the air travels faster at top than at the bottom.
- Since the speed of air is higher on the top surface than the bottom, the pressure is lower than that at the bottom surface. This causes a pressure difference which causes a net upward lifting force which helps the plane to rise.

Practical examples:

1. Explain why a thatched roof of a house can be completely lifted off the house by a strong wind.

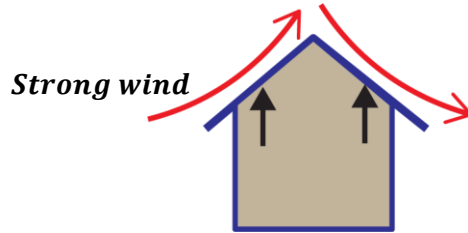

A strong wind moves over the roof top with a high speed thus creating a lower pressure above the roof top than the pressure below the roof.

Since the pressure below the roof is higher than that at the top, it causes an upward force which lifts up the roof resulting into blowing of the roof.

2. Explain using Bernoulli's principle why it is dangerous to stand near the edge of a platform in a railway station, when a fast-moving train is passing by.



This is because a person standing near a fast-moving train will tend to fall towards it according to Bernoulli's principle.

The speed of air molecules between the fast-moving train and the person is high thus creating a region of low pressure. Since the pressure behind the person is now greater than pressure in front of the person, it pushes the person towards the train.

VISCOSITY:

When water is poured on a person's head, it runs through his/her hair and then flows over the face quickly. But when honey is poured on the person's head, it takes a lot of time to flow through the person's head. This is because of a property of fluids called **viscosity**.

Definition:

Viscosity is the measure of fluid's resistance to flow.

Therefore, honey is thicker than water so it has a high viscosity than water.

Viscous fluid:

This is a fluid with a high viscosity. Therefore, a viscous fluid doesn't flow easily.

Examples of viscous fluids include;

- ♦ Honey
- ♦ Oil
- ♦ Glues
- ♦ Syrups

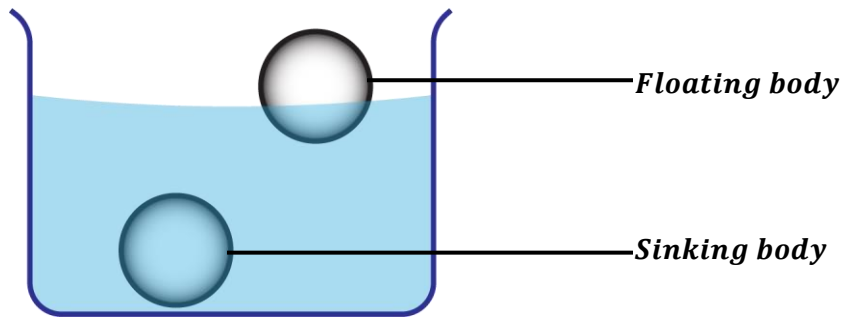
FLOATING AND SINKING

- ❖ If you lift a bucket of water from a tank, the bucket appears to be lighter inside the water and suddenly heavy when it comes out of water.
 - ❖ When we go swimming, we feel a little weightless in the water than our actual weight.
 - ❖ A large ship made of metal (steel) floats on water while a small steel pin sinks in water.
- Therefore, an object weighs less in water than it does in air. This loss of weight is due to the upthrust of water acting on the object.
- All the above experiences can be explained by Archimedes' principle formulated by a Greek mathematician called **Archimedes**.

ARCHIMEDES' PRINCIPLE:

It states that when a body is wholly or partially immersed in a fluid, it experiences an upthrust equal to the weight of the fluid displaced.

$$\text{Upthrust} = \text{Weight of the fluid displaced}$$

Terms used in Archimedes' principle:

- **Upthrust (Buoyancy):**
This is the upward force that a fluid exerts on a body falling through it.
- **Actual weight:**
This is the weight of the body in air.
- **Apparent weight:**
This is the weight of the body when completely immersed or submerged in a fluid.
Apparent weight is always less than the actual weight.
- **Apparent loss in weight:**
This is the difference between actual weight of a body and apparent weight of the body.
 $\text{Apparent loss in weight} = \text{Actual weight} - \text{Apparent weight}$

Apparent loss in weight is also equal to upthrust.

Therefore,

$$\text{Upthrust} = (\text{actual weight} - \text{apparent weight})$$

Also,

$$\text{Apparent weight} = \text{Actual weight} - \text{Upthrust}$$

Factors affecting upthrust acting on the body

Density of the fluid:

Denser liquids exert greater upthrust on a body immersed in it than less dense liquids.

E.g. salty water is denser than fresh water therefore, an object immersed in salty water displaces a greater weight of the salty water (upthrust) than when in fresh water. Thus, the body feels weightless.

Volume of body immersed the fluid:

A body experiences a greater upthrust when fully or wholly immersed in a fluid than when it is partially immersed.

Practical examples:

- ❖ The figure below shows a uniform bar in equilibrium with two equal masses suspended at an equal distance from the pivot from either ends.

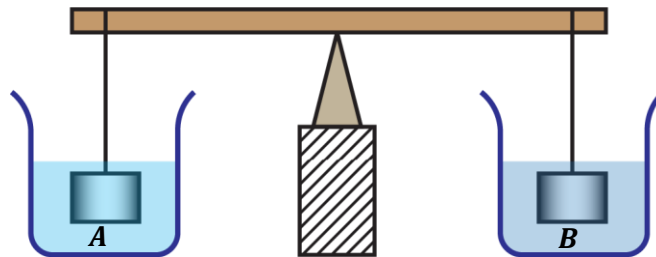

Salt water is added into beaker **A** and fresh water in beaker **B** until the masses are fully submerged. It is observed the bar tips towards beaker **B**. Explain this observation.

Salt water is denser than fresh water so it exerts a greater upthrust on the mass immersed in beaker A. Therefore, the mass in beaker A displaces a greater weight of the salty water.

The apparent weight of mass in beaker A is therefore lower than the apparent weight of mass in beaker B. This causes the bar to tilt towards B.

- ❖ The figure below shows weights of a ball suspended on a spring balance when weighed in air and water respectively.

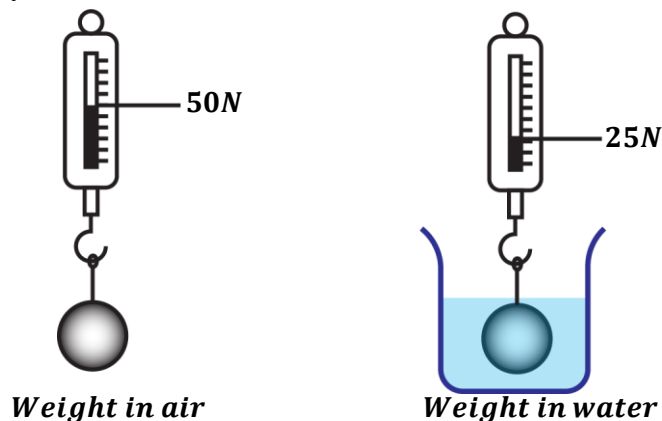

Explain why the weight of the ball in water is less than the weight of the ball in air.

This is because when the ball is submerged in water, it experiences an upthrust thus lowering the apparent weight of the ball.

Recall, $\boxed{\text{Apparent weight} = \text{Actual weight} - \text{Upthrust}}$

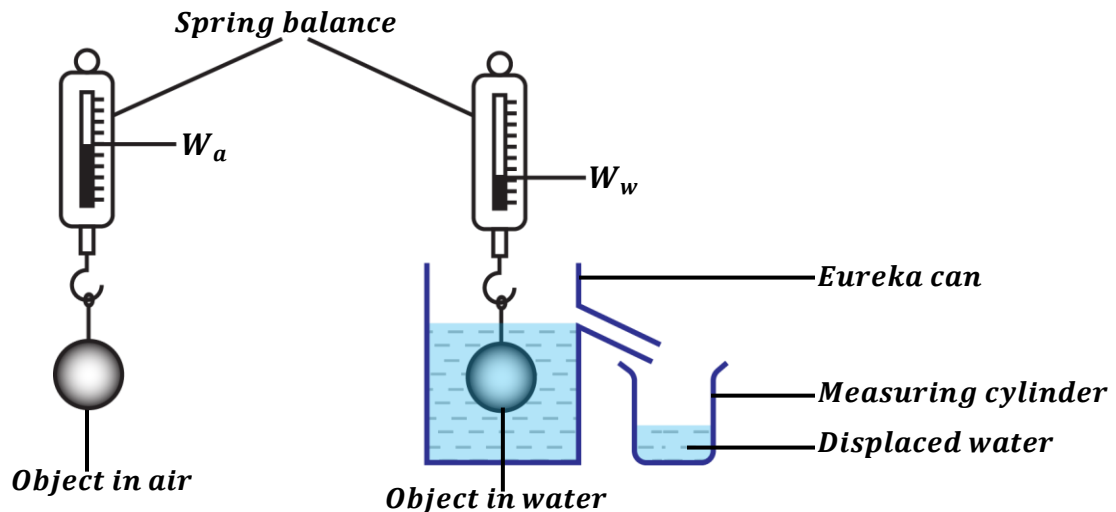
EXPERIMENT TO VERIFY ARCHIMEDES' PRINCIPLE

- An object is weighed in air using a spring balance and its weight in air, W_a is recorded.
- An eureka can (displacement can) is completely filled with water up to its spout.
- An empty beaker of known weight, W_b is placed under the spout of the eureka can.
- The object is then weighed when completely immersed in water using a spring balance and its weight in water, W_w is recorded.
- The weight of the beaker and displaced water, W_{b+d} is measured and recorded.
- The weight of displaced water is then calculated from $W_d = W_{b+d} - W_b$.
- Since upthrust is equal to apparent loss in weight, it is calculated from $U = W_a - W_w$.
- It is found out that upthrust is equal to weight of displaced water (i.e. $U = W_d$) thus verifying Archimedes' principle.

CALCULATIONS INVOLVING ARCHIMEDES' PRINCIPLE

- ❖ When a body is immersed in a fluid, it experiences an apparent loss in weight which is equal to the upthrust acting on the body.

Therefore, *Upthrust = Apparent loss in weight*

$$\text{Upthrust} = \text{weight in air} - \text{weight in fluid}$$

$$\boxed{\text{Upthrust} = W_a - W_f}$$

- ❖ According to Archimedes' principle;

$$\text{Upthrust} = \text{weight of displaced fluid}$$

$$\text{Upthrust} = \text{mass of displaced fluid} \times \text{acceleration due to gravity}$$

$$\text{Upthrust} = m_f \times g$$

But mass = density \times volume

$$\text{Upthrust} = \rho_f \times V_f \times g$$

$$\boxed{\text{Upthrust} = V_f \rho_f g}$$

Where V_f – density of water.

ρ_f – volume of displaced water.

NOTE:

The volume of displaced fluid is equal to the volume of the body immersed in the fluid.

Recall: Displacement of finding volume of an irregular object.

Examples:

(Where necessary use density of water as 1000kgm^{-3})

1. A block weighs 25N in air. When completely immersed in water, it weighs 10N. Calculate;
- upthrust on the block.
 - volume of water displaced.

$$W_a = 25\text{N}, \quad W_w = 10\text{N}$$

i)

$$\begin{aligned} \text{Upthrust} &= W_a - W_w \\ \text{Upthrust} &= 25 - 10 \\ \text{Upthrust} &= 15\text{N} \end{aligned}$$

ii)

$$\begin{aligned} \text{Upthrust} &= \text{weight of displaced water} \\ \text{Upthrust} &= V_w \rho_w g \\ 15 &= V_w \times 1000 \times 10 \\ V_w &= \frac{15}{10000} \\ V_w &= 0.0015\text{m}^3 \end{aligned}$$

2. A metal weighs 20N in air and 15N when fully immersed in water. Calculate;
- upthrust.
 - weight of displaced water.
 - volume of displaced water.

$$W_a = 20\text{N}, \quad W_w = 15\text{N}$$

i)

$$\begin{aligned} \text{Upthrust} &= W_a - W_w \\ \text{Upthrust} &= 20 - 15 \\ \text{Upthrust} &= 5\text{N} \end{aligned}$$

ii)

$$\begin{aligned} \text{Weight of displaced water} &= \text{Upthrust} \\ \text{Weight of displaced water} &= 5\text{N} \end{aligned}$$

iii)

$$\begin{aligned} \text{Upthrust} &= \text{weight of displaced water} \\ \text{Upthrust} &= V_w \rho_w g \\ 5 &= V_w \times 1000 \times 10 \\ V_w &= \frac{5}{10000} \\ V_w &= 0.0005\text{m}^3 \end{aligned}$$

3. A concrete block of mass $3.0 \times 10^3\text{kg}$ and volume 1.2m^3 is totally immersed in a fluid of density $2.0 \times 10^3\text{kgm}^{-3}$. Find;
- weight of the block in air.
 - Weight of the block in the fluid.

$$m_b = 3.0 \times 10^3\text{kg}, \quad V_b = V_f = 1.2\text{m}^3 \quad \rho_f = 2.0 \times 10^3\text{kgm}^{-3}$$

i)

$$\begin{aligned} W_a &= m_b g \\ W_a &= (3.0 \times 10^3) \times 10 \\ W_a &= 30000\text{N} \end{aligned}$$

ii)

$$\begin{aligned} \text{Upthrust} &= \text{weight of displaced fluid} \\ \text{Upthrust} &= V_f \rho_f g \\ \text{Upthrust} &= (1.2) \times (2.0 \times 10^3) \times (10) \\ \text{Upthrust} &= 24000\text{N} \\ \text{Upthrust} &= W_a - W_f \\ 24000 &= 30000 - W_f \\ W_f &= 6000\text{N} \end{aligned}$$

4. An object weighs 30N in air and 25N when immersed in water. Calculate;
- upthrust.
 - volume of the object.
 - density of the object.

$$W_a = 30N, \quad W_w = 25N$$

i)

$$\begin{aligned} \text{Upthrust} &= W_a - W_w \\ \text{Upthrust} &= 30 - 25 \\ \text{Upthrust} &= 5N \end{aligned}$$

ii)

Upthrust = weight of displaced water

$$\begin{aligned} \text{Upthrust} &= V_w \rho_w g \\ 5 &= V_w \times 1000 \times 10 \\ V_w &= \frac{5}{10000} \end{aligned}$$

$$V_w = 0.0005m^3$$

volume of object = volume of displaced water

$$\begin{aligned} V_o &= V_w \\ V_o &= 0.0005m^3 \end{aligned}$$

iii) Density of object

$$\begin{aligned} W_a &= V_o \rho_o g \\ 30 &= 0.0005 \times \rho_o \times 10 \\ \rho_o &= \frac{30}{0.005} \end{aligned}$$

$$\rho_o = 6000kgm^{-3}$$

OR

$$\rho_o = \frac{\text{mass of object } (m_o)}{\text{volume of object } (V_o)}$$

From $W_a = m_o g$

$$m_o = \frac{30}{10} = 3kg$$

$$\begin{aligned} \rho_o &= \frac{3}{0.0005} \\ \rho_o &= 6000kgm^{-3} \end{aligned}$$

5. A body weighs 50N in air and 30N when fully immersed in water. Calculate the mass of water displaced.

$$W_a = 50N, \quad W_w = 30N$$

$$\begin{aligned} \text{Upthrust} &= W_a - W_w \\ \text{Upthrust} &= 50 - 30 \\ \text{Upthrust} &= 20N \end{aligned}$$

Upthrust = weight of displaced water

$$\begin{aligned} \text{Upthrust} &= m_w g \\ 20 &= m_w \times 10 \\ m_w &= \frac{20}{10} \\ m_w &= 2kg \end{aligned}$$

6. A piece of metal of density $2500kgm^{-3}$ weighs 1N in air. Find the weight of the metal when completely submerged in water.

$$W_a = 1N, \quad W_w = ?, \quad \rho_m = 2500kgm^{-3}$$

Volume of metal

$$\begin{aligned} W_a &= V_m \rho_m g \\ 1 &= V_m \times 2500 \times 10 \\ V_m &= \frac{1}{25000} \end{aligned}$$

$$V_m = 0.00004m^3$$

volume of metal = volume of displaced water

$$V_w = V_m = 0.00004m^3$$

Upthrust = weight of displaced water

$$\begin{aligned} \text{Upthrust} &= V_w \rho_w g \\ \text{Upthrust} &= 0.00004 \times 1000 \times 10 \\ \text{Upthrust} &= 0.4N \end{aligned}$$

$$\begin{aligned} \text{Upthrust} &= W_a - W_w \\ 0.4 &= 1 - W_w \\ W_w &= 0.6N \end{aligned}$$

7. An object weighs 50N in air and 30N when wholly submerged in water. Calculate;
- Buoyant force on the object.
 - volume of the object.
 - density of object.

$$W_a = 50N, \quad W_w = 30N$$

i)

$$\text{Upthrust} = W_a - W_w$$

$$\text{Upthrust} = 50 - 30$$

$$\text{Upthrust} = 20N$$

ii)

Upthrust = weight of displaced water

$$\text{Upthrust} = V_w \rho_w g$$

$$20 = V_w \times 1000 \times 10$$

$$V_w = \frac{20}{10000}$$

$$V_w = 0.002m^3$$

volume of object = volume of displaced water

$$V_o = V_w$$

$$V_o = 0.002m^3$$

iii) *Density of object*

$$W_a = V_o \rho_o g$$

$$50 = 0.002 \times \rho_o \times 10$$

$$\rho_o = \frac{50}{0.02}$$

$$\rho_o = 2500kgm^{-3}$$

OR

$$\rho_o = \frac{\text{mass of object } (m_o)}{\text{volume of object } (V_o)}$$

From $W_a = m_o g$

$$m_o = \frac{50}{10} = 5kg$$

$$\rho_o = \frac{5}{0.002}$$

$$\rho_o = 2500kgm^{-3}$$

8. A solid of volume $800cm^3$ is totally immersed in oil of density $0.8gcm^{-3}$. Calculate the
- mass of oil displaced.
 - upthrust on the solid.

i)

$$V_s = 800cm^3 \quad V_o = 800cm^3 \quad \rho_o = 0.8gcm^{-3}$$

$$\text{mass of oil} = \text{density of oil} \times \text{volume of oil}$$

$$m_o = \rho_o \times V_o$$

$$m_o = 0.8 \times 800$$

$$m_o = 640g$$

ii)

Upthrust = weight of displaced oil

$$\text{Upthrust} = m_o g$$

$$\text{Upthrust} = \left(\frac{640}{1000}\right) \times 10$$

$$\text{Upthrust} = 6.4N$$

NOTE:

When a body is partially immersed in a fluid, it displaces a volume of a fluid equal to the fraction of its volume that is immersed in the fluid.

i.e. *Volume of displaced fluid = fraction of the volume of body immersed in the fluid.*

9. An iron cube of mass $480g$ and density $8gcm^{-3}$ is suspended by a string so that it is half immersed in oil of density $0.9gcm^{-3}$. Find
- upthrust acting on the cube.
 - the tension in the string.

$$m_c = 480g = \frac{480}{1000} = 0.48kg,$$

$$\rho_c = 8gcm^{-3} = (8 \times 1000) = 8000kgm^{-3}$$

$$\rho_o = 0.9gcm^{-3} = (0.9 \times 1000) = 900kgm^{-3}$$

volume of iron cube

$$V_c = \frac{m_c}{\rho_c}$$

$$V_c = \frac{0.48}{8000} = 0.00006m^3$$

volume of displaced oil

$$V_o = \frac{1}{2} \times \text{volume of iron cube}$$

$$V_o = \frac{1}{2} \times 0.00006 = 0.00003m^3$$

i)

Upthrust = weight of displaced oil

$$Upthrust = V_o \rho_o g$$

$$Upthrust = 0.00003 \times 900 \times 10$$

$$Upthrust = 0.27N$$

ii)

weight of cube in air

$$W_a = m_c g = 0.48 \times 10$$

$$W_a = 4.8N$$

Tension = Apparent weight (W_o)

Apparent weight = weight of cube in oil

$$Upthrust = W_a - W_o$$

$$0.27 = 4.8 - W_o$$

$$W_o = 4.53N$$

EXERCISE:

(Where necessary use density of water as $1000kgm^{-3}$)

- A body weighs $100N$ in air and $80N$ in water. Calculate.
 - upthrust on the body.
 - volume of displaced water.
 - density of the body.
 - mass of the body.
- A string supports a solid block of mass $1kg$ and density $9000kgm^{-3}$ which is completely immersed in water. Calculate the tension in the string.
- A stone of volume $200cm^3$ and density $2.7gcm^{-3}$ is completely immersed in Kerosene.
 - Determine the upthrust exerted on the stone.
 - Determine how much it will weigh in kerosene (*density of kerosene = $0.8gcm^{-3}$*)
- A glass block of mass 2.0×10^3kg and volume $2.4m^3$ is totally immersed in a fluid of density $1.0 \times 10^3kgm^{-3}$. Find;
 - weight of the block in air.
 - Weight of the block in the fluid.
- An iron cube of volume $800cm^3$ is totally immersed in
 - Water
 - oil of density $0.8gcm^{-3}$
 Calculate the upthrust in each case.

DETERMINING RELATIVE DENSITY OF A SOLID USING ARCHIMEDES' PRINCIPLE

- The solid is weighed in air and its weight, W_a is recorded.
- The solid is then weighed when completely immersed in water and its weight, W_w is recorded.

$$\text{Relative density of solid} = \frac{\text{Weight of solid in air}}{\text{Apparent loss of weight in water}}$$

$$\text{Relative density of solid} = \frac{\text{Weight of solid in air}}{\text{Upthrust}}$$

$$\boxed{R.D = \frac{W_a}{W_a - W_w}}$$

Recall:

$$\text{Relative density} = \frac{\text{Density of substance}}{\text{Density of equal volume of water}}$$

Examples:

(Where necessary use density of water as 1000kgm^{-3})

1. A solid weighs 25N. It weighs 15N when completely immersed in water. Calculate;
 - i) relative density of a solid.
 - ii) density of a solid.

<p>i) $W_a = 25\text{N}, \quad W_w = 15\text{N}$</p> $R.D = \frac{W_a}{W_a - W_w}$ $R.D = \frac{25}{25 - 15}$ $R.D = 2.5$		<p>ii)</p> $R.D = \frac{\text{Density of solid}}{\text{Density of water}}$ $R.D = \frac{\rho_s}{\rho_w}$ $2.5 = \frac{\rho_s}{1000}$ $\rho_s = 2500\text{kgm}^{-3}$
--	--	---

2. A metallic solid weighs 24N and 16N when completely immersed in water. Calculate;
 - i) relative density of the metal.
 - ii) density of the metal.

<p>i) $W_a = 24\text{N}, \quad W_w = 16\text{N}$</p> $R.D = \frac{W_a}{W_a - W_w}$ $R.D = \frac{24}{24 - 16}$ $R.D = 3$		<p>ii)</p> $R.D = \frac{\text{Density of metallic solid}}{\text{Density of water}}$ $R.D = \frac{\rho_s}{\rho_w}$ $3 = \frac{\rho_s}{1000}$ $\rho_s = 3000\text{kgm}^{-3}$
--	--	--

3. An object has a relative density of 7 and weighs 70N in air. Find its weight when it is fully immersed in water.

$$W_a = 70N, \quad W_w = ? \quad R.D = 7$$

$$R.D = \frac{W_a}{W_a - W_w}$$

$$7 = \frac{70}{70 - W_w}$$

$$490 - 7W_w = 70$$

$$W_w = \frac{490 - 70}{7}$$

$$W_w = 60N$$

4. A body weighs 600g in air and 400g in water. Calculate;

- upthrust on the body.
- volume of the body.
- relative density of the solid.

From **weight = mg**

$$W_a = \frac{600}{1000} \times 10 = 6N$$

$$W_w = \frac{400}{1000} \times 10 = 4N$$

a) **Upthrust** = $W_a - W_w$
Upthrust = $6 - 4$
Upthrust = $2N$

b) **Upthrust** = **weight of displaced water**

$$\text{Upthrust} = V_w \rho_w g$$

$$2 = V_w \times 1000 \times 10$$

$$V_w = \frac{2}{10000}$$

$$V_w = 0.0002m^3$$

c)

$$R.D = \frac{W_a}{W_a - W_w}$$

$$R.D = \frac{6}{6 - 4}$$

$$R.D = 3$$

DETERMINING RELATIVE DENSITY OF A LIQUID USING ARCHIMEDES' PRINCIPLE

- The solid is weighed in air and its weight, W_a is recorded.
- The solid is then weighed when completely immersed in water and its weight, W_w is recorded.
- The solid is then weighed when completely immersed in another liquid and its weight, W_l is recorded.

$$\text{Relative density of solid} = \frac{\text{Apparent loss of weight in liquid}}{\text{Apparent loss of weight in water}}$$

$$\text{Relative density of solid} = \frac{\text{Upthrust in liquid}}{\text{Upthrust in water}}$$

$$R.D = \frac{W_a - W_l}{W_a - W_w}$$

Examples:

(Where necessary use density of water as 1000kgm^{-3})

1. A metal weighs 25N in air and 20N in water and 15N in a liquid. Calculate;
 a) relative density of the liquid.
 b) density of the liquid.

	$W_a = 25N,$	$W_w = 20N$	$W_l = 15N$
a)			b)
	$R.D = \frac{W_a - W_l}{W_a - W_w}$		$R.D = \frac{\text{Density of liquid}}{\text{Density of water}}$
	$R.D = \frac{25 - 15}{25 - 20}$		$R.D = \frac{\rho_l}{\rho_w}$
	$R.D = \frac{10}{5}$		$2 = \frac{\rho_l}{1000}$
	$R.D = 2$		$\rho_l = 2000\text{kgm}^{-3}$

2. A solid weighs 55N in air. When in a liquid, it weighs 25N and it weighs 30N when in water. Calculate;
 i) relative density of the liquid.
 ii) density of the liquid.

	$W_a = 55N,$	$W_w = 25N$	$W_l = 30N$
c)			d)
	$R.D = \frac{W_a - W_l}{W_a - W_w}$		$R.D = \frac{\text{Density of liquid}}{\text{Density of water}}$
	$R.D = \frac{55 - 25}{55 - 30}$		$R.D = \frac{\rho_l}{\rho_w}$
	$R.D = \frac{30}{25}$		$1.2 = \frac{\rho_l}{1000}$
	$R.D = 1.2$		$\rho_l = 1200\text{kgm}^{-3}$

3. An object weighs 100N in air and 40N in kerosene of relative density 0.8. Find its weight in water.

$$W_a = 100N, \quad W_l = 40N, \quad W_w = ? \quad R.D = 0.8$$

$$R.D = \frac{W_a - W_l}{W_a - W_w}$$

$$0.8 = \frac{100 - 40}{100 - W_w}$$

$$80 - 0.8W_w = 60$$

$$W_w = \frac{80 - 60}{0.8}$$

$$W_w = 25N$$

4. A body weighs 20g in air, 18.2g in milk and 18g in water. Calculate;
 a) the relative density of the body.
 b) the relative density of the milk.

From weight = mg

$$W_a = \frac{20}{1000} \times 10 = 0.2N \quad W_l = \frac{18.2}{1000} \times 10 = 0.182N \quad W_w = \frac{18}{1000} \times 10 = 0.18N$$

a) relative density of body

$$R.D = \frac{W_a}{W_a - W_w}$$

$$R.D = \frac{0.2}{0.2 - 0.18}$$

$$R.D = 10$$

b) relative density of milk

$$R.D = \frac{W_a - W_l}{W_a - W_w}$$

$$R.D = \frac{0.2 - 0.182}{0.2 - 0.18}$$

$$R.D = 0.9$$

5. When a metal is completely immersed in liquid A, its apparent weight is 20N. When immersed in another liquid B, the apparent weight is 16N. If the density of the liquid is $\frac{9}{8}$ times that of A, calculate the weight of metal in air.

$W_{LA} = 20N, \quad W_{LB} = 16N$ $R.D = \frac{\text{Density of liquid A}}{\text{Density of liquid B}}$ $R.D = \frac{\rho_A}{\rho_B}$ $R.D = \frac{\rho_A}{\frac{9\rho_A}{8}}$ $R.D = \frac{8}{9}$	$R.D = \frac{\text{Upthrust in liquid A}}{\text{Upthrust in liquid B}}$ $R.D = \frac{W_a - W_{LA}}{W_a - W_{LB}}$ $\frac{8}{9} = \frac{W_a - 20}{W_a - 16}$ $8W_a - 128 = 9W_a - 180$ $W_a = 52N$
---	---

EXERCISE

- A piece of glass weighs 0.5N in air and 0.3N in water and 0.32N in benzene. Calculate;
 - relative density of glass.
 - density of glass.
 - relative density of liquid.
 - density of benzene.
- An object weighs 5.6N in air, 4.8N in water and 4.6N when immersed in a liquid. Find the relative density of the liquid.
- A piece of iron weighs 555N in air. When completely immersed in water, it weighs 530N and weighs 535N when completely immersed in alcohol. Calculate the relative density of alcohol.
- A glass block weighs 43N in air. When wholly immersed in water, the block weighs 23N. Calculate the;
 - upthrust on the glass block.
 - density of the glass block.
 - volume of the glass block.
- A solid weighs 0.50N in air. It weighs 0.30N when fully immersed in water and 0.32N when fully submerged in a liquid. Calculate the;
 - upthrust on the body due to water.
 - volume of the solid.
 - density of the solid
 - relative density of the liquid.
 - density of the liquid.
- A solid weighs 600g in air, 450g in water and 480g in a liquid. Find the;
 - relative density of the liquid.
 - density of the liquid.

FLOATATION

Recall: A body floats in a fluid if its average density is less than the density of the fluid.

When an object is placed in liquid, it is acted upon by the upthrust and its weight.

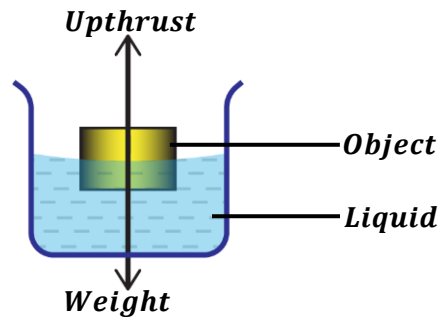

- ❖ The object sinks in the liquid if its weight is greater than upthrust.
- ❖ The object floats in the liquid if its weight is equal to upthrust. Therefore, the apparent weight (resultant force on the object) must be zero for a body to float in the liquid.

However, when a cork is held below the liquid surface (e.g. water), and released, it rises because its upthrust is greater than its weight.

Note: By Archimedes' principle, *Upthrust = weight of displaced fluid*. Therefore, for a floating body, its weight is equal to weight of displaced fluid.

LAW OF FLOATATION:

It states that a floating body displaces its own weight of the fluid in which it floats.

$$\boxed{\text{Weight of floating body} = \text{Weight of displaced fluid}}$$

Mathematically;

$$\begin{aligned} W_b &= W_f \\ m_b g &= m_f g \\ m_b &= m_f \quad [\text{mass of floating body} = \text{mass of displaced fluid}] \\ \rho_b V_b &= \rho_f V_f \end{aligned}$$

Examples:

1. A piece of wood of density 2.5 gcm^{-3} and volume 100 cm^3 floats on a liquid of density 4 gcm^{-3} . Calculate the volume of liquid displaced.

$$\rho_w = 2.5 \text{ gcm}^{-3}, \quad V_w = 100 \text{ cm}^3, \quad \rho_l = 4 \text{ gcm}^{-3}, \quad V_l = ?$$

Weight of floating wood = weight of displaced liquid

$$\begin{aligned} W_w &= W_l \\ m_w g &= m_l g \\ m_w &= m_l \\ \rho_w V_w &= \rho_l V_l \\ 2.5 \times 100 &= 4 \times V_l \\ V_l &= \frac{250}{4} \\ V_l &= 62.5 \text{ cm}^3 \end{aligned}$$

2. A piece of cork of density 0.15gcm^{-3} and volume 200cm^3 floats in water of density 1gcm^{-3} . Calculate the volume of the cork out of the water.

$$\rho_c = 0.15\text{gcm}^{-3}, \quad V_c = 200\text{cm}^3, \quad \rho_w = 1\text{gcm}^{-3}, \quad V_w = ?$$

Weight of floating cork = weight of displaced water

$$W_c = W_w$$

$$m_c g = m_w g$$

$$m_c = m_w$$

$$\rho_c V_c = \rho_w V_w$$

$$0.15 \times 200 = 1 \times V_w$$

$$V_w = \frac{30}{1}$$

$$V_w = 30\text{cm}^3$$

Volume of cork out of water = volume of cork – volume of displaced water

$$\text{Volume of cork out of water} = 200 - 30$$

$$\text{Volume of cork out of water} = 170\text{cm}^3$$

3. A piece of cork of volume 100cm^3 is floating on water. If the density of cork is 0.25gcm^{-3} . Calculate the volume of the cork immersed in water. (density of water is 1gcm^{-3}).

$$\rho_c = 0.25\text{gcm}^{-3}, \quad V_c = 100\text{cm}^3, \quad \rho_w = 1\text{gcm}^{-3}, \quad V_w = ?$$

Weight of floating cork = weight of displaced water

$$W_c = W_w$$

$$m_c g = m_w g$$

$$m_c = m_w$$

$$\rho_c V_c = \rho_w V_w$$

$$0.25 \times 100 = 1 \times V_w$$

$$V_w = \frac{25}{1}$$

$$V_w = 25\text{cm}^3$$

Volume of cork immersed in water = volume of displaced water

$$\text{Volume of cork immersed in water} = 25\text{cm}^3$$

4. A glass block of density 5gcm^{-3} and volume 200cm^3 floats on a liquid of density 8000kgm^{-3} . Calculate the volume of liquid displaced.

$$\rho_g = 5\text{gcm}^{-3} = (5 \times 1000) = 5000\text{kgm}^{-3}, \quad \rho_l = 8000\text{kgm}^{-3}$$

$$V_g = 200\text{cm}^3 = \frac{200}{1000000} = 0.0002\text{m}^3, \quad V_l = ?$$

Weight of floating glass = weight of displaced liquid

$$W_g = W_l$$

$$m_g g = m_l g$$

$$m_g = m_l$$

$$\rho_g V_g = \rho_l V_l$$

$$5000 \times 0.0002 = 8000 \times V_l$$

$$V_l = \frac{1}{8000}$$

$$V_l = 0.000125\text{m}^3$$

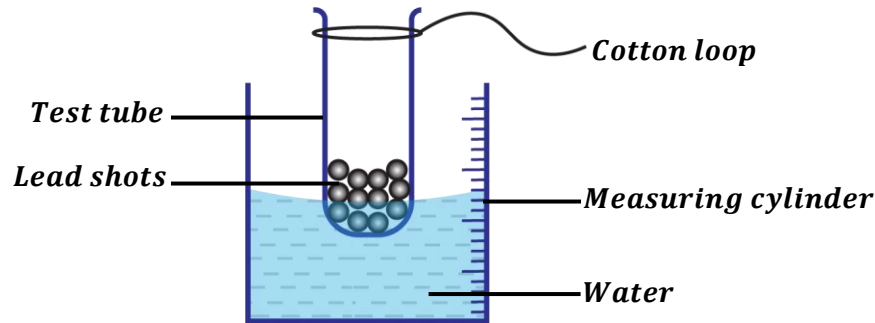
EXPERIMENT TO VERIFY THE LAW OF FLOATATION

- A measuring cylinder is filled with some water and its initial volume V_1 is recorded.
- A test tube with a cotton loop is then placed in the measuring cylinder.
- Lead shots are then added to the test tube until the test tube floats vertically.
- The reading of the new water level V_2 is recorded.
- Volume of water displaced by test tube is calculated as $(V_2 - V_1)$.
- The weight of displaced water = $\rho_w(V_2 - V_1)g$.
- The test tube with lead shots is then removed from water, dried and weighed and its weight is recorded. (The cotton loop helps to attach the test tube to the spring balance)
- It is found that (*weight of test tube + lead shots*) is equal to the weight of displaced water thus verifying the law of floatation.

OR

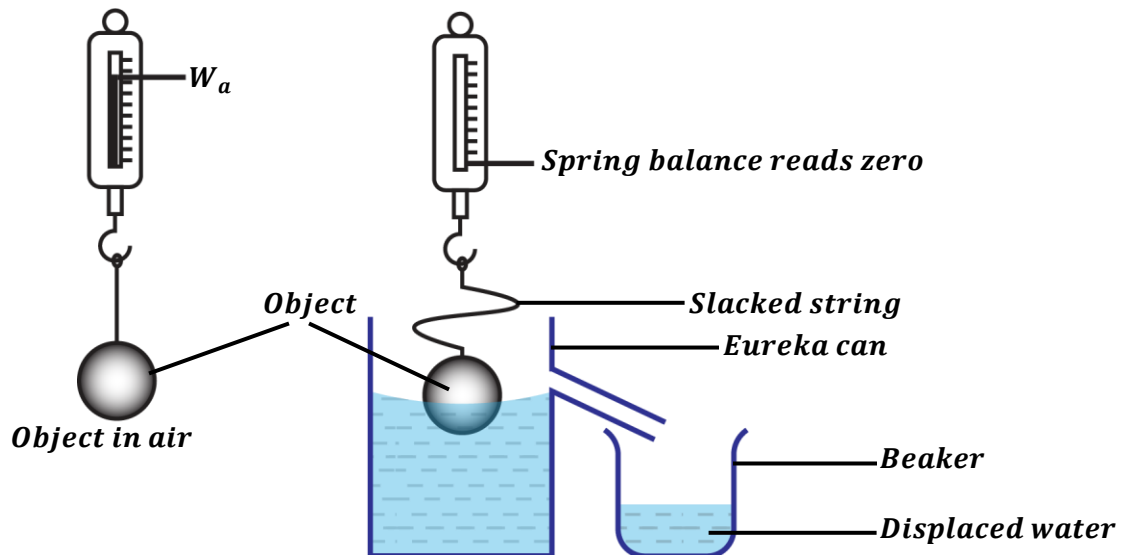

- An object is weighed in air using a spring balance and its weight in air, W_a is recorded.
- An eureka can (displacement can) is completely filled with water up to its spout.
- An empty beaker of known weight, W_b is placed under the spout of the eureka can.
- The object is made to float on water in the Eureka can (displacement can) and displaced water is collected in the beaker.
- The weight of the beaker and displaced water, W_{b+d} is measured and recorded.
- The weight of displaced water is then calculated from $W_d = W_{b+d} - W_b$.
- It is found out that weight of the object in air is equal to the weight of displaced water ($W_a = W_d$), thus verifying the law of floatation.

Fraction of a floating body submerged in a fluid:

weight of floating body = weight of displaced fluid

$$W_b = W_f$$

$$m_b g = m_f g$$

$$m_b = m_f \quad [\text{mass of floating body} = \text{mass of displaced fluid}]$$

$$\rho_b V_b = \rho_f V_f$$

Therefore,

$$\text{Fraction of body submerged} = \frac{\rho_b}{\rho_f} = \frac{V_f}{V_b}$$

$$\text{Fraction of body submerged} = \frac{\text{Density of floating body}}{\text{Density of fluid}}$$

OR

$$\text{Fraction of body submerged} = \frac{\text{Volume of displaced fluid}}{\text{Volume of floating body}}$$

Examples:

1. A piece of wood floats with $\frac{4}{5}$ of its volume under a liquid of density 800kgm^{-3} . Find the density of the wood.

$$\text{Fraction of wood submerged} = \frac{\text{Density of floating wood}}{\text{Density of liquid}}$$

$$\text{Fraction of wood submerged} = \frac{\rho_w}{\rho_l}$$

$$\frac{4}{5} = \frac{\rho_w}{800}$$

$$\rho_w = \frac{800 \times 4}{5}$$

$$\rho_w = 640 \text{kgm}^{-3}$$

2. An object of volume 240cm^3 floats with three quarters of its volume under water. Calculate the
- density of the object if the density of water is 1000kgm^{-3} .
 - volume of displaced water

i)

$$\text{Fraction submerged} = \frac{3}{4}, \quad \rho_w = 1000 \text{kgm}^{-3}$$

$$\text{Fraction of object submerged} = \frac{\text{Density of floating object}}{\text{Density of water}}$$

$$\text{Fraction of object submerged} = \frac{\rho_o}{\rho_w}$$

$$\frac{3}{4} = \frac{\rho_o}{1000}$$

$$\rho_o = \frac{1000 \times 3}{4}$$

$$\rho_o = 750 \text{kgm}^{-3}$$

ii)

$$V_o = 240\text{cm}^3 = \frac{240}{1000000} = 0.00024\text{m}^3$$

$$\text{Fraction of object submerged} = \frac{\text{Volume of displaced water}}{\text{Volume of floating object}}$$

$$\begin{aligned} \text{Fraction of object submerged} &= \frac{V_w}{V_o} \\ \frac{3}{4} &= \frac{V_w}{0.00024} \\ V_w &= \frac{0.00024 \times 3}{4} \\ V_w &= 0.00018\text{m}^3 \end{aligned}$$

OR

Weight of floating object = Weight of displaced water

$$\begin{aligned} W_o &= W_w \\ m_o g &= m_w g \\ m_o &= m_w \\ \rho_o V_o &= \rho_w V_w \\ 750 \times 0.00024 &= 1000 \times V_w \\ V_w &= \frac{0.18}{1000} \\ V_w &= 0.00018\text{m}^3 \end{aligned}$$

 3. The mass of a piece of cork of density 0.25gcm^{-3} is 20g .

 a) What fraction of the cork is immersed when it floats in water? (Density of water is 1gcm^{-3})

b) What is the volume of displaced water?

a)

$$m_c = 20\text{g}, \quad \rho_c = 0.25\text{gcm}^{-3}, \quad \rho_w = 1\text{gcm}^{-3}$$

$$\text{Fraction of cork submerged} = \frac{\text{Density of floating cork}}{\text{Density of water}}$$

$$\begin{aligned} \text{Fraction of object submerged} &= \frac{\rho_c}{\rho_w} \\ \text{Fraction of object submerged} &= \frac{0.25}{1} \\ \text{Fraction of object submerged} &= \frac{1}{4} \end{aligned}$$

b)

$$\begin{aligned} \text{volume of cork} \\ V_c &= \frac{m_c}{\rho_c} \\ V_c &= \frac{20}{0.25} = 80\text{cm}^3 \end{aligned}$$

$$\text{Fraction of cork submerged} = \frac{\text{Volume of displaced water}}{\text{Volume of floating cork}}$$

$$\begin{aligned} \text{Fraction of cork submerged} &= \frac{V_w}{V_c} \\ \frac{1}{4} &= \frac{V_w}{80} \\ V_w &= \frac{80}{4} \\ V_w &= 20\text{cm}^3 \end{aligned}$$

OR

Weight of floating cork = Weight of displaced water

$$\begin{aligned} W_c &= W_w \\ m_c g &= m_w g \\ m_c &= m_w \\ \rho_c V_c &= \rho_w V_w \\ 0.25 \times 80 &= 1 \times V_w \\ V_w &= \frac{20}{1} \\ V_w &= 20\text{cm}^3 \end{aligned}$$

4. A cube made of oak and of height 15cm floats in water with 10.5cm of its height below the surface. Calculate;

- a) fraction of oak immersed in water.
b) density of oak. (Density of water is 1gcm^{-3})

a)

$$\text{Fraction of object submerged} = \frac{10.5}{15}$$

$$\text{Fraction of object submerged} = \frac{7}{10}$$

b)

$$\text{Fraction of oak submerged} = \frac{\text{Density of floating oak}}{\text{Density of water}}$$

$$\text{Fraction of oak submerged} = \frac{\rho_o}{\rho_w}$$

$$\frac{7}{10} = \frac{\rho_o}{1 \times 7}$$

$$\rho_o = \frac{10}{7}$$

$$\rho_o = 0.7\text{gcm}^{-3}$$

5. An object of Relative density 0.8 floats in water. Find

- i) fraction of object immersed in water.
ii) fraction of object exposed.

(Density of water is 1000kgm^{-3})

i)

$$R.D = \frac{\text{Density of object}}{\text{Density of water}}$$

$$R.D = \frac{\rho_o}{\rho_w}$$

$$0.8 = \frac{\rho_o}{1000}$$

$$\rho_o = 800\text{kgm}^{-3}$$

$$\text{Fraction of object submerged} = \frac{\rho_o}{\rho_w}$$

$$\text{Fraction of object submerged} = \frac{800}{1000}$$

$$\text{Fraction of object submerged} = \frac{4}{5}$$

ii)

$$\text{Fraction exposed} = 1 - \frac{4}{5}$$

$$\text{Fraction exposed} = \frac{1}{5}$$

EXERCISE:

1. A solid of volume $10m^3$ floats in water of density 10^3kgm^{-3} with $\frac{3}{5}$ of its volume submerged. Calculate;
 - a) the mass of the solid.
 - b) the density of the solid.
2. A piece of wood of density $5gcm^{-3}$ and volume $200cm^3$ floats on a liquid of density $8gcm^{-3}$. Calculate the volume of wood immersed in the liquid.
3. A piece of wood of volume $40cm^3$ floats in water with only half of volume submerged. If the density of water is $1000kgm^{-3}$, calculate the density of wood.
4. A piece of wood of volume $30cm^3$ on a liquid of density $0.8g/cm^3$ with $\frac{2}{3}$ of its volume immersed in the liquid. Determine the weight of the piece of wood.
5. A solid of volume $2.0 \times 10^{-4}m^3$ floats in water of density 10^3kgm^{-3} with $\frac{3}{4}$ of its volume submerged. Find the mass of the solid.
6. A block of wood of volume $100cm^3$ and density $500kg/m^3$ floats in a liquid of density $800kg/m^3$. Calculate the volume of wood submerged in the liquid.
7. A slab of ice of volume $800cm^3$ and density $0.9gcm^{-3}$ floats in water of density $1.1gcm^{-3}$. What fraction of ice slab is above the salt water?

APPLICATIONS OF THE LAW OF FLOATATION
1. Ships:

A ship is able to float whenever the upthrust is equal to its weight. Thus, it displaces an amount of water equal to its weight.



Plimsoll lines

Why ships float on water

Ships float on water although they are made from iron and steel (metals) which are denser than water. This is because the ship is made hollow and contains air so that the average density of the ship is less than that of water.

If a hole develops on one side of a ship, the ship will take in water making its average density more than that of water thus it sinks.

NOTE:

The plimsoll lines (loading lines) on the sides of the ship show the level to which the ship can be safely loaded so that it can float on water.

2. Submarines:

Submarines can float on water and can sink in water. The average density of a submarine is varied by the ballast tanks.

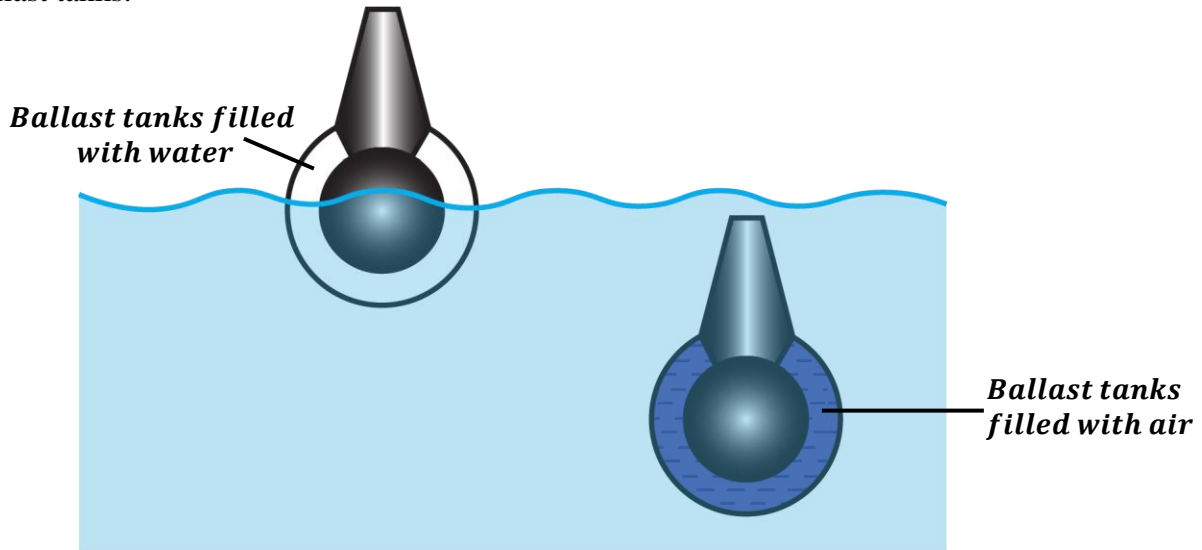

- ❖ For submarines to float, the ballast tanks are filled with air so that the average density of the submarine is less than that of water.
- ❖ For submarines to sink, the ballast tanks are filled with water so that the average density of the submarine is greater than that of water.

3. Hydrometer:

This is a device used to find the relative density of a liquid by noting how far it floats in a liquid.

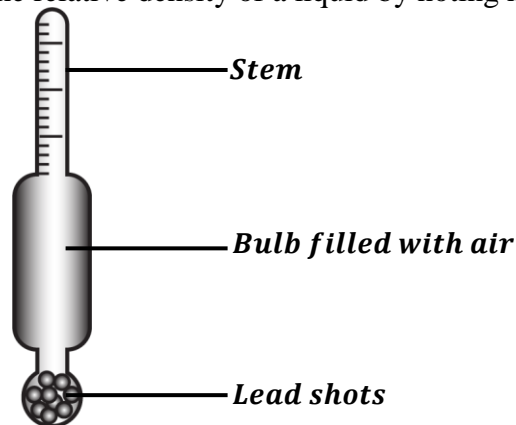

It consists of;

- a long and thin stem which makes the hydrometer more sensitive.
- a bulb filled with air with lead shots at the bottom. The lead shots keep the hydrometer upright when it floats in a liquid. Lead shots lower the centre of gravity of the hydrometer which increases its stability.

How to increase sensitivity of a hydrometer.

- By making the stem very thin (narrow)
- By making the bulb large.

Uses of a hydrometer:

- It is used to test the purity of milk.
- It is used to determine the level of sugar in some drinks (Lactometer).
- It is used to determine the relative density of a car battery acid (Car battery tester).

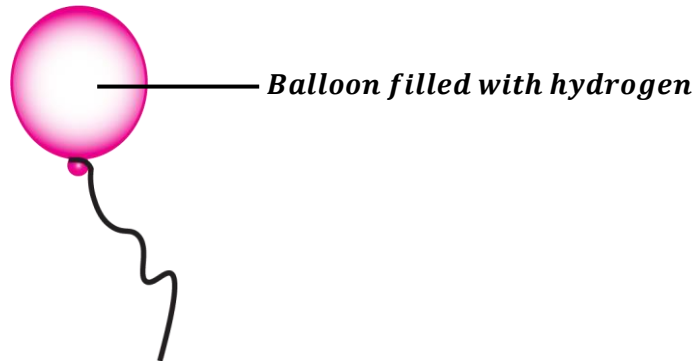
4. Balloons:

A balloon filled with hydrogen rises in air because the density of hydrogen is less than the density of air in the atmosphere. Therefore, the upthrust acting on the balloon is greater than the weight of the balloon hence causing it to rise.

The balloon rises until when it becomes stationary. At this point, the weight of the balloon is equal to upthrust hence it starts to float.

NOTE: Balloons that carry passengers control their weight by blowing in hot gases into the gas bag to make them rise and letting out gases out of the gas bag to make them go down.

When the balloon is floating in air,

$$\text{Upthrust} = \text{weight of displaced air}$$

$$\text{Upthrust} = \text{Weight of balloon} + \text{Weight of hydrogen gas} + \text{weight of load}$$

Examples:

1. A balloon of mass 0.005kg is inflated with hydrogen gas and held stationary on the ground by a string. If the volume of inflated balloon is 0.005m^3 .

- a) Calculate the upthrust acting on the balloon (Lifting force of the balloon)
 - b) Calculate the tension in the string.
- (Density of hydrogen = 0.080kgm^{-3} , Density of air = 1.150kgm^{-3})

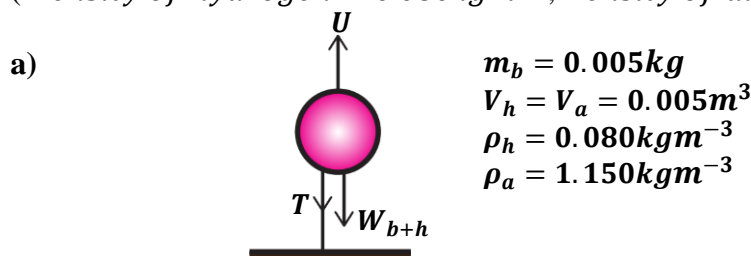

$$\text{Upthrust} = \text{Weight of displaced air}$$

$$\text{Upthrust} = m_a g$$

$$\text{Upthrust} = \rho_a \times V_a \times g$$

$$\text{Upthrust} = 1.150 \times 0.005 \times 10$$

$$\text{Upthrust} = 0.0575\text{N}$$

b) **Upthrust = Weight of balloon + Weight of hydrogen + Tension of string**
Upthrust = $m_b g + m_h g + T$
Upthrust = $m_b g + \rho_h V_h g + T$
 $0.0575 = (0.005 \times 10) + (0.080 \times 0.005 \times 10) + T$
 $0.0575 = 0.054 + T$
 $T = 0.0035N$

2. A balloon of mass 5g is inflated with hydrogen and held stationary by a string. If the volume of the balloon is $0.005m^3$, find the tension in the string.
 (Assume hydrogen is a light gas and density of air = $1.25kgm^{-3}$)

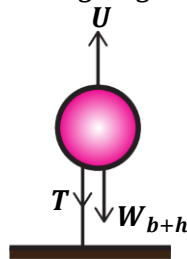

$$m_b = 5g = \frac{5}{1000} = 0.005kg$$

$$V_h = V_a = 0.005m^3$$

$$m_h = 0kg \text{ (negligible)}$$

$$\rho_a = 1.25kgm^{-3}$$

Upthrust = Weight of displaced air
Upthrust = $m_a g$
Upthrust = $\rho_a \times V_a \times g$
Upthrust = $1.25 \times 0.005 \times 10$
Upthrust = $0.0625N$

But also;

Upthrust = Weight of balloon + Weight of hydrogen + Tension of string
Upthrust = $m_b g + m_h g + T$
 $0.0625 = (0.005 \times 10) + 0 + T$
 $0.0625 = 0.05 + T$
 $T = 0.0125N$

3. A balloon has a capacity $10m^3$ and is filled with hydrogen. The balloon's fabric and container have a mass of $1.25kg$. Calculate the maximum weight in the container the balloon can lift.
 (Density of hydrogen = $0.089kgm^{-3}$, Density of air = $1.29kgm^{-3}$)

$$m_b = 1.25kg$$

$$V_h = V_a = 10m^3$$

$$\rho_h = 0.089kgm^{-3}$$

$$\rho_a = 1.29kgm^{-3}$$

Upthrust = Weight of displaced air
Upthrust = $m_a g$
Upthrust = $\rho_a V_a g$

But also;

Upthrust = Weight of balloon + Weight of hydrogen + Weight of load
 $\rho_a V_a g = m_b g + m_h g + W_L$
 $\rho_a V_a g = m_b g + \rho_h V_h g + W_L$
 $(1.29 \times 10 \times 10) = (1.25 \times 10) + (0.089 \times 10 \times 10) + W_L$
 $129 = 21.4 + W_L$
 $W_L = 107.6N$

4. Explain what happens to a balloon;
- When it is filled with air and its open end tied and released.
When a balloon is filled with air, the upthrust is less than the weight of the fabric of the balloon and the weight of air inside the balloon. The resultant force causes the balloon to move slowly downwards.
 - When it is filled with hydrogen gas and its open end tied and released.
When the balloon is filled with hydrogen (or helium), which is less dense than air, the upthrust is greater than the weight of the balloon and its contents. Therefore, the balloon rises until when upthrust is equal to the weight of balloon and its content thus making the balloon to float.

EXERCISE:

- A balloon of capacity 20m^3 and is filled with hydrogen. The balloon's fabric and container have a mass of 2.5kg . Calculate the maximum mass of the load the balloon can lift
(Density of hydrogen = 0.089kgm^{-3} , Density of air = 1.29kgm^{-3})
- A hot air balloon is made from a very light material. It displaces 360kg of air and contains 300m^3 of hydrogen gas of density 0.08kgm^{-3} . Find the maximum load the balloon can lift.
- The envelope of a hot-air balloon contains 1500m^3 of hot air of density 0.8kgm^{-3} . The mass of the balloon (not including the hot air) is 420kg . The density of the surrounding air is 1.3kgm^{-3} . Calculate the lifting force of the balloon.
- A weather forecasting balloon is made of a fabric of mass 40kg . Calculate the volume of hydrogen in the balloon which would just support an additional load of mass 80kg when floating in air.
(Density of hydrogen = 0.09kgm^{-3} , Density of air = 1.29kgm^{-3})
- A weather forecasting balloon of volume 15m^3 contains hydrogen of density 0.09kgm^{-3} . The volume of container carried by the balloon is negligible. The mass of empty balloon alone is 7.15kg . The balloon is floating in air of density 1.29kgm^{-3} . Calculate;
 - the mass of hydrogen in the balloon.
 - the mass of hydrogen and the balloon.
 - the mass of air displaced by the balloon

HEAT

When you put a cup of very hot porridge on a table, the porridge cools down after sometime. This means that some energy has been transferred from the porridge to the surrounding. This form of energy that is transferred is called heat.

Definition:

Heat is the form of energy which flows from one point to another due to temperature difference between the two points.

Heat energy flows from a region of high temperature to a region of low temperature.

The **SI** unit of heat energy is a joule (**J**).

Effects of heat on a body:

When a body absorbs heat energy,

- Its temperature increases thus becoming hot.
- Its state changes e.g. solid changes to liquid.
- It makes the body to expand.

When a body loses heat energy,

- Its temperature decreases thus becoming cold.
- It makes the body to contract.

TEMPERATURE

Temperature is a number which expresses the degree of hotness or coldness of a body on a chosen scale.

Temperature of a body depends on the average kinetic energy of the molecules in that body. Therefore, temperature can also be defined as *measure of the average kinetic energy of the molecules in the body*.

Measurement of temperature:

Temperature of a body is measured by an instrument called a **thermometer**.

The **SI** unit of temperature is the **Kelvin (K)**.

Other units include;

- Degrees Celsius ($^{\circ}C$)
- Degrees Fahrenheit ($^{\circ}F$)

Thermometers measure temperatures of a body basing on certain physical properties which change continuously with temperature. These physical properties are called thermometric properties.

Definition:

A **thermometric property** is a physical property which changes continuously with temperature.

Examples of thermometric properties:

They include;

- Length of a liquid column (e.g. liquid-in-glass thermometer).
- Electrical resistance of a wire (e.g. platinum resistance wire).
- Pressure of a fixed mass of a gas at constant volume (e.g. constant-volume gas thermometer).
- Volume of a fixed mass of a gas at constant pressure (e.g. constant-pressure gas thermometer).
- Electromotive force of a thermocouple (e.g. thermocouple thermometer).

Qualities of a good thermometric property:

- It should vary continuously and linearly with change in temperature.
- It should vary considerably for a small change in temperature.
- It should vary over a wide range of temperatures i.e. both high and low temperatures.
- It should be accurately measurable over a wide range of temperature with a simple apparatus.

TEMPERATURE SCALES

A temperature scale is a scale in which the degree of hotness or coldness can be expressed. These scales include:

- ❖ Fahrenheit scale.
- ❖ Celsius scale (centigrade scale).
- ❖ Kelvin scale (thermodynamic scale).

Fahrenheit scale:

Temperature on the Fahrenheit scale is measured in degrees Fahrenheit ($^{\circ}\text{F}$).

To convert from degrees Celsius to degrees Fahrenheit, the formula below is used.

$$^{\circ}\text{F} = \frac{9}{5}\text{C} + 32$$

Celsius scale:

Temperature on the Celsius scale is measured in degrees Celsius ($^{\circ}\text{C}$).

The lower fixed point (melting point of ice) is 0°C and the upper fixed (boiling point of water) is 100°C .

To convert from degrees Fahrenheit to degrees Celsius, the formula below is used.

$$^{\circ}\text{C} = \frac{5}{9}(\text{F} - 32)$$

Kelvin scale:

Temperature on the Kelvin or thermodynamic scale is measured in Kelvins (K).

The lower fixed point (melting point of ice) is $273K$ and the upper fixed (boiling point of water) is $373K$.

Relationship between the Celsius scale and Kelvin scale

If temperature, θ ($^{\circ}\text{C}$) on the Celsius scale is related to temperature, T (K) on the Kelvin scale, then;

$$T = \theta + 273$$

$$\theta = T - 273$$

Examples:

1. Convert the following temperature readings to Kelvins.

i) 127°C

$$T = \theta + 273$$

$$T = 127 + 273$$

$$T = 400K$$

ii) 30°C

$$T = \theta + 273$$

$$T = 30 + 273$$

$$T = 303K$$

iii) -27°C

$$T = \theta + 273$$

$$T = -27 + 273$$

$$T = 246K$$

iv) 0°C

$$T = \theta + 273$$

$$T = 0 + 273$$

$$T = 273K$$

v) -240°C

$$T = \theta + 273$$

$$T = -240 + 273$$

$$T = 33K$$

vi) 26.5°C

$$T = \theta + 273$$

$$T = 26.5 + 273$$

$$T = 299.5K$$

2. Convert the following temperature readings to degrees Celsius.

i) 23K
 $\theta = T - 273$
 $\theta = 23 - 273$
 $\theta = -250^{\circ}\text{C}$

ii) 233K
 $\theta = T - 273$
 $\theta = 233 - 273$
 $\theta = -40^{\circ}\text{C}$

iii) 54K
 $\theta = T - 273$
 $\theta = 54 - 273$
 $\theta = -219^{\circ}\text{C}$

iv) 0°C
 $\theta = T - 273$
 $\theta = 0 - 273$
 $\theta = -273^{\circ}\text{C}$

v) 600K
 $\theta = T - 273$
 $\theta = 600 - 273$
 $\theta = 327^{\circ}\text{C}$

vi) 574K
 $\theta = T - 273$
 $\theta = 574 - 273$
 $\theta = 301^{\circ}\text{C}$

FIXED POINTS OF A THERMOMETER

A **fixed point** is a constant temperature at which a physical change takes place at standard atmospheric pressure.

There are basically two types of fixed points namely;

- Lower fixed point.
- Upper fixed point.

LOWER FIXED POINT (ICE POINT):

This is the temperature of pure melting ice at standard atmospheric pressure.

The lower fixed point is 0°C on the Celsius scale and 273K on the Kelvin scale.

An experiment to determine the lower fixed point of an uncalibrated thermometer

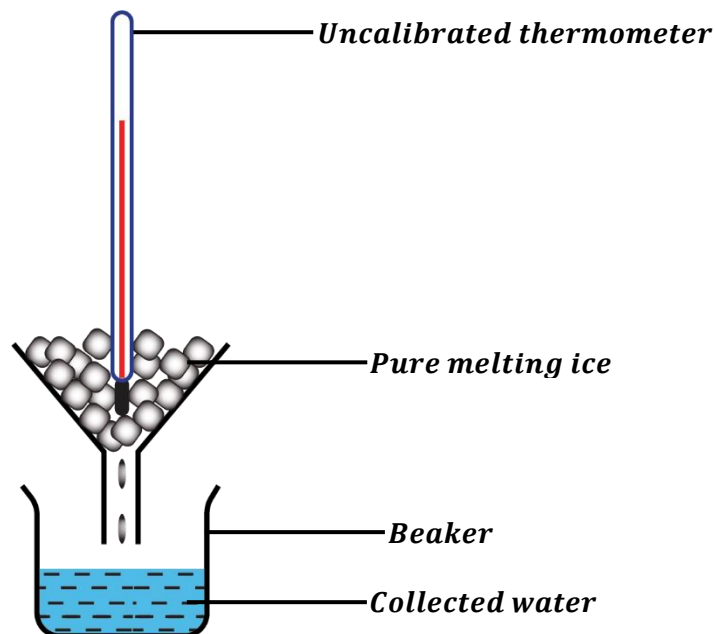

- The thermometer to be marked is placed in pure melting ice inside a funnel with ice cubes packed around its bulb.
- The thermometer is left in ice for some time until the level of mercury remains stationary.
- This level is then marked and it is the lower fixed point of the thermometer.

NOTE:

- The ice must be pure because impurities in ice lower the melting point of ice.

UPPER FIXED POINT (STEAM POINT):

This is the temperature of pure boiling water at standard atmospheric pressure.

The lower fixed point is 100°C on the Celsius scale and 373K on the Kelvin scale.

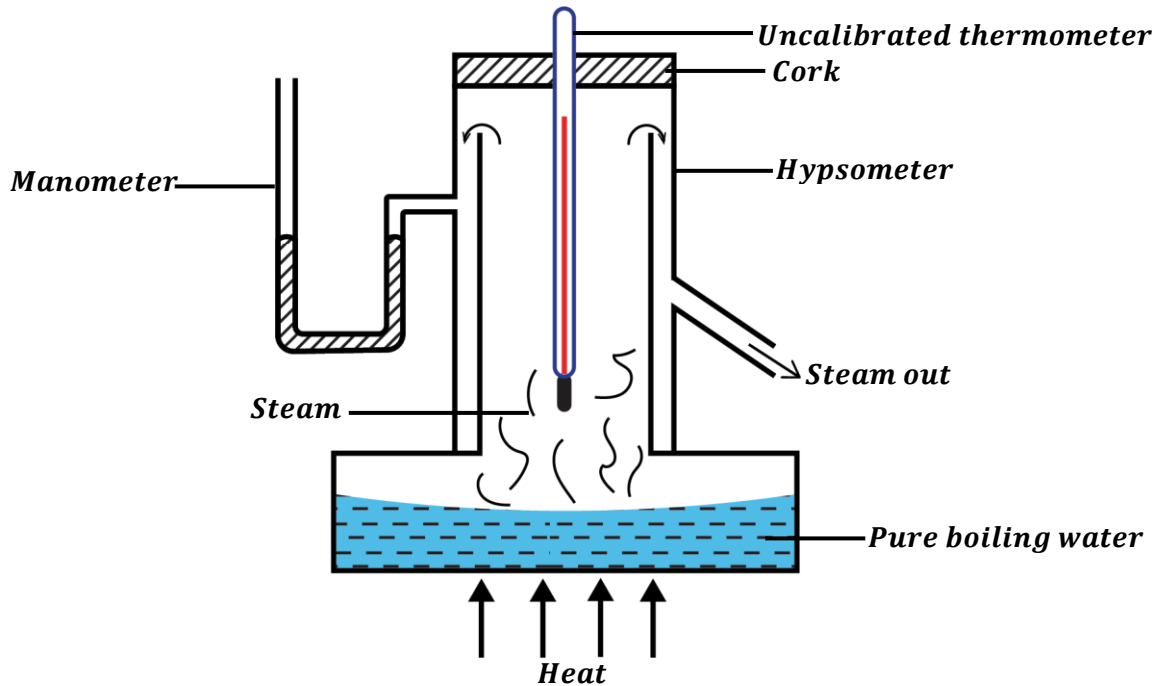
An experiment to determine the upper fixed point of an uncalibrated thermometer

- Some water is poured into a hypsometer
- The thermometer to be marked is placed in the hypsometer through a hole in the cork.
- Water is boiled to generate steam that surrounds the bulb of the thermometer.
- The thermometer is left in steam for some time until the level of mercury remains stationary.
- This level is then marked and it is the upper fixed point of the thermometer.

NOTE:

- The double walls of the hypsometer ensure that the temperature of steam is always constant (i.e. it's always 100°C). Thus, they reduce heat loss to the surrounding.
- The manometer ensures that the standard pressure is always constant (i.e. it's always 76mmHg).
- When performing the above experiment, the bulb should not touch the surface of boiling water.

LIQUID-IN-GLASS THERMOMETERS

These are the most commonly used thermometers in the world.

They use liquids in their capillary tubes to measure temperatures.

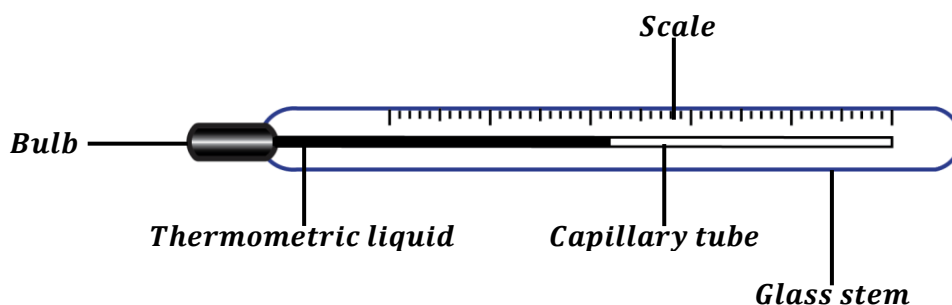
Structure of a liquid-in-glass thermometer:

It consists of a thin walled bulb at the end of a capillary tube.

The bulb and some part of the capillary tube is filled with a thermometric liquid which expands so as to measure temperature.

The common thermometric liquids used are mercury and alcohol.

How to use a liquid in thermometer:

- The bulb is kept in direct contact with the body whose temperature is to be measured.
- The thermometric liquid expands through the capillary tube.
- The thermometer is left in contact with the body for sometime until the level of thermometric liquid (mercury) remains stationary or steady.
- The thermometer reading becomes the temperature of the body

Precautions taken when designing (constructing) a liquid-in-glass thermometer:

- ❖ The walls of the glass bulb should be thin. This ensures that the thermometric liquid e.g. mercury is heated easily.
- ❖ The amount of thermometric liquid in the bulb should be small. This is because a small amount of the liquid takes less time to warm up therefore, it gives a quick response.
- ❖ The capillary tube should be uniform. This ensures that the expansion of the thermometric liquid is also uniform.
- ❖ The bore of the capillary tube should be made narrow. This makes the thermometer to be more sensitive in detecting small changes in temperature.
- ❖ The glass wall of the stem is made thick. This ensures that the inner parts of the thermometer are well protected.

NOTE:

The space above the thermometric liquid is usually evacuated to avoid excess pressure from being developed when mercury expands.

THERMOMETRIC LIQUIDS:

There are two liquids that are mainly used in a liquid-in-glass thermometer namely;

- Mercury.
- Alcohol.

Choice of a thermometric liquid:

The choice of the thermometric liquid depends on the range of temperature to be measured.

Mercury freezes at -39°C (freezing point) and boils at 357°C (boiling point).

Alcohol freezes at -115°C (freezing point) and boils at 78°C (boiling point).

Therefore, alcohol is suitable to measure very low temperatures and mercury is suitable to measure very high temperatures.

Qualities of a good thermometric liquid:

- It should be opaque so that it can easily be seen.
- It should not wet glass i.e. it should not stick on the walls of the thermometer.
- It should be a good conductor of heat. This ensures that it responds to any change in temperature.
- It should have a regular or uniform expansion. i.e. its expansion should be the same at different points of the scale.
- It should have a high boiling point so as to measure very high temperatures.
- It should have a low freezing point so as to measure very low temperatures.
- It should have a high expansivity i.e. it should expand so much for a small temperature change.

Reasons why water is not used as a thermometric liquid:

- It is transparent (not opaque) so it cannot be easily seen.
- It wets glass i.e. it sticks on the walls the thermometer.
- It doesn't expand regularly.
- It has a high freezing point (0°C) so it cannot be used to measure very low temperatures that are less than 0°C.
- It has a low boiling point (100°C) so it cannot be used to measure very high temperatures that are beyond 100°C.
- It is a poor conductor of heat.
- Its meniscus is difficult to read.

Advantages of mercury over alcohol when used as a thermometric liquid:

- Mercury is opaque so it can easily be seen.
- Mercury does not wet the glass of the thermometer.
- Mercury has a high boiling point (357°C) so, it can be used to measure very high temperatures.
- Mercury has a regular or uniform expansion.
- Mercury is a good conductor of heat.

Disadvantages of mercury over alcohol when used as a thermometric liquid:

- Mercury has a high freezing point (−39°C) so it cannot be used to measure very low temperatures.
- Mercury has a low expansivity i.e. it expands less for a small change in temperature.

Advantages of alcohol over mercury when used as a thermometric liquid:

- Alcohol has a low freezing point (−115°C) so, it can be used to measure very low temperatures.
- Mercury has a high expansivity i.e. it expands so much for a small change in temperature.

Disadvantages of alcohol over mercury when used as a thermometric liquid:

- Alcohol is not opaque (transparent) so it cannot easily be seen.
- Alcohol tends to wet the glass of the thermometer.
- Alcohol has a low boiling point (78°C) so, it cannot be used to measure very high temperatures.
- Alcohol has an irregular or non-uniform expansion compared to mercury.
- Alcohol is relatively a poor conductor of heat when compared to mercury.

DETERMINING TEMPERATURE ON AN UNCALIBRATED THERMOMETER:

The length between the lower fixed point and the upper fixed is called the **fundamental interval**.

Method 1:

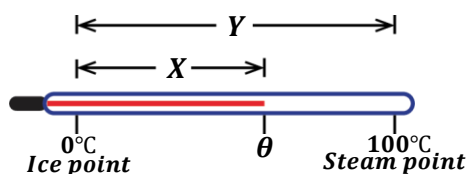

If X is the length of the mercury thread above the lower fixed point (ice point) and Y is the length between the lower and upper fixed points (fundamental interval), then the unknown temperature, θ can be obtained from the expression below.

$$\theta = \frac{\text{Length of mercury thread above the ice point}}{\text{Fundamental interval}} \times 100^\circ\text{C}$$

$$\theta = \frac{X}{Y} \times 100^\circ\text{C}$$

Method 2:

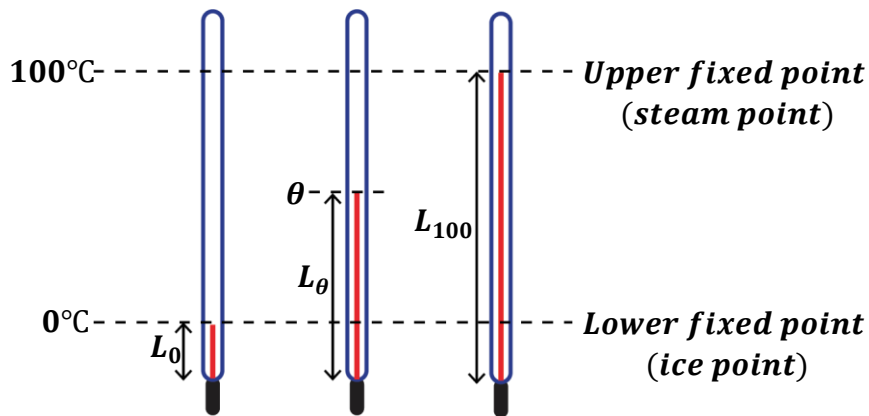

If L_0 is the length of mercury thread at lower fixed point (0°C), L_{100} is the length of mercury thread at the upper fixed point (100°C) and L_θ is the length of mercury thread at unknown temperature, θ , then the unknown temperature can be obtained from the expression below;

$$\theta = \frac{\text{Length of mercury thread above the ice point}}{\text{Fundamental interval}} \times 100^\circ\text{C}$$

$$\theta = \frac{L_\theta - L_0}{L_{100} - L_0} \times 100^\circ\text{C}$$

Examples:

- When a thermometer is placed in a boiling liquid, the mercury thread rises above the lower fixed point by 18.5cm . Find the temperature of the liquid if the fundamental interval is 20cm .

$$X = 18.5\text{cm}, \quad Y = 20\text{cm}$$

$$\theta = \frac{X}{Y} \times 100^\circ\text{C}$$

$$\theta = \frac{18.5}{20} \times 100^\circ\text{C}$$

$$\theta = 92.5^\circ\text{C}$$

- The length on the stem of a mercury-in-glass thermometer between the lower and upper fixed points is 18cm . when the bulb is dipped in a hot liquid, the mercury level is found to be 10cm above the ice point. Calculate the temperature of the liquid.

$$X = 10\text{cm}, \quad Y = 18\text{cm}$$

$$\theta = \frac{X}{Y} \times 100^\circ\text{C}$$

$$\theta = \frac{10}{18} \times 100^\circ\text{C}$$

$$\theta = 55.6^\circ\text{C}$$

- The fundamental interval of the thermometer is 18cm . How far above the ice point will the mercury level be when the bulb is in a region at a temperature of 60°C ?

$$Y = 18\text{cm}, \quad \theta = 60^\circ\text{C}$$

$$\theta = \frac{X}{Y} \times 100^\circ\text{C}$$

$$60 = \frac{X}{18} \times 100^\circ\text{C}$$

$$X = \frac{60 \times 18}{100}$$

$$X = 12\text{cm}$$

4. The length of the mercury thread of a thermometer at ice point is 22cm and that at steam point is 62cm . Calculate the reading of the thermometer when the mercury thread is 42cm long.

$$L_0 = 22\text{cm}, \quad L_{100} = 62\text{cm}, \quad L_\theta = 42\text{cm}$$

$$\theta = \frac{L_\theta - L_0}{L_{100} - L_0} \times 100^\circ\text{C}$$

$$\theta = \frac{42 - 22}{62 - 22} \times 100^\circ\text{C}$$

$$\theta = \frac{20}{40} \times 100^\circ\text{C}$$

$$\theta = 50^\circ\text{C}$$

5. In an uncalibrated thermometer, the length of the mercury above the bulb is 38mm at lower fixed point and 138mm at upper fixed point. When the thermometer is placed in a hot liquid, the length of the mercury thread above the bulb is 78mm . Calculate the temperature of the hot liquid.

$$L_0 = 38\text{mm}, \quad L_{100} = 138\text{mm}, \quad L_\theta = 78\text{mm}$$

$$\theta = \frac{L_\theta - L_0}{L_{100} - L_0} \times 100^\circ\text{C}$$

$$\theta = \frac{78 - 38}{138 - 38} \times 100^\circ\text{C}$$

$$\theta = \frac{40}{100} \times 100^\circ\text{C}$$

$$\theta = 40^\circ\text{C}$$

6. A mercury thermometer is calibrated by immersing it in melting pure ice and then in boiling pure water. If the mercury columns are 6cm and 16cm respectively, find the temperature when the mercury column is 8cm long.

$$L_0 = 6\text{cm}, \quad L_{100} = 16\text{cm}, \quad L_\theta = 8\text{cm}$$

$$\theta = \frac{L_\theta - L_0}{L_{100} - L_0} \times 100^\circ\text{C}$$

$$\theta = \frac{8 - 6}{16 - 6} \times 100^\circ\text{C}$$

$$\theta = \frac{2}{10} \times 100^\circ\text{C}$$

$$\theta = 20^\circ\text{C}$$

7. The resistance of a platinum resistance thermometer is 5.7Ω at ice point, 5.2Ω at steam point and 5.5Ω at unknown temperature. Determine the unknown temperature.

$$R_0 = 5.2\Omega, \quad R_{100} = 5.7\Omega, \quad R_\theta = 5.5\Omega$$

$$\theta = \frac{R_\theta - R_0}{R_{100} - R_0} \times 100^\circ\text{C}$$

$$\theta = \frac{5.5 - 5.2}{5.7 - 5.2} \times 100^\circ\text{C}$$

$$\theta = \frac{0.3}{0.5} \times 100^\circ\text{C}$$

$$\theta = 60^\circ\text{C}$$

CLINICAL THERMOMETER

This is an example of liquid-in-glass thermometer since it uses mercury as its thermometric liquid. It is designed to be used in clinics and hospitals to measure the temperature of human beings.

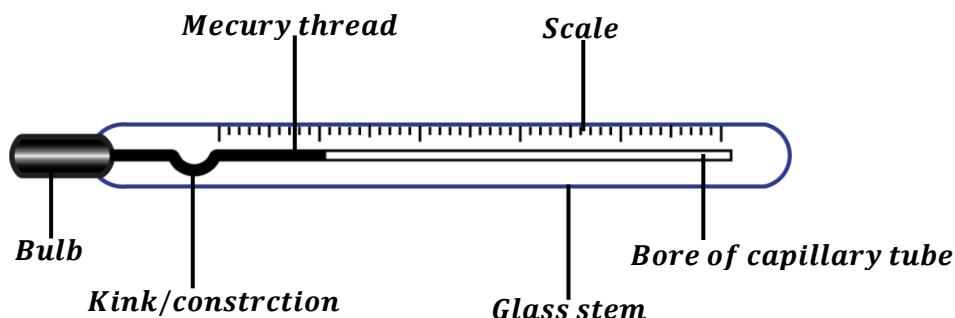

The clinical thermometer measures a small range of temperatures i.e. 35°C to 42°C since the temperature of the human body cannot go outside that.

How to use a clinical thermometer:

- The thermometer is placed in the person's arm pit (or other parts of the body) for about 2 minutes.
- The mercury from the bulb expands until it reaches a level when it is no longer changing (stationary).
- The thermometer is withdrawn from the human body and the level of mercury thread is read off.
- This mercury level gives the temperature of the human body.

NOTE:

- ❖ The use of the kink or constriction is to prevent the back flow of mercury when temperature is being read.
- ❖ It is not advisable to sterilize a clinical thermometer in boiling water, since this makes mercury to expand far beyond the space provided in the bore. Hence, this may lead to bursting of the thermometer.
- ❖ The thermometer should be shaken before it is used on another patient so as to allow mercury go back to bulb.

SENSITIVITY OF A THERMOMETER

A thermometer is said to be sensitive if it can detect or measure very small changes in temperature.

Conditions for a thermometer to be sensitive.

- The thermometer should have a large bulb.
If the bulb is large, it will contain a greater volume of mercury thus leading to greater expansion of mercury per degree.
- The thermometer should have a very narrow bore.
If the bore of the capillary tube is made narrow, a small change in volume of mercury will fill a greater length of the capillary tube.

Other types of thermometers:

Apart from liquid-in-thermometers, other thermometers include;

- Thermocouple thermometers.
- Platinum resistance thermometers.
- Constant-volume gas thermometers.
- Constant-pressure gas thermometers.

EXERCISE:

- “A thermometer is sensitive”. Explain what is meant by the statement.
 - State two ways of increasing the sensitivity of a thermometer.
- What is meant by the term thermometric property?
 - State any three thermometric properties that you know.
 - List two properties of a good thermometric liquid.
- Define the following terms.
 - Lower fixed point.
 - Fundamental interval.
 - With the aid of a diagram, describe how the upper fixed point of an uncalibrated can be determined.
- The interval between the ice and steam points on a thermometer is 192mm. Find the temperature when the length of the mercury thread is 67.2mm from the ice point.
- The distance between the lower and upper fixed points on the Celsius scale on an unmarked mercury glass thermometer is 25cm. If the mercury level is 5cm below the upper fixed point, calculate the temperature value at that level.
- Convert the following temperature readings to the Celsius scale.
 - 283K
 - 167K
 - 973K
 - 3960K
- Convert the following temperature readings to the Kelvin scale.
 - 25°C
 - 353°C
 - 237°C
- For a liquid in glass thermometer, what are the governing factors for choosing the liquid to be used?
 - Give three reasons why water is not used as a thermometric liquid.
 - When a Celsius thermometer is inserted in a boiling liquid, the mercury thread rises above the lower fixed point by 19.5cm. Find the temperature of the boiling liquid if the fundamental interval is 25cm.
- Define a fixed point as used in thermometry.
 - Under what circumstances could alcohol be preferred to mercury as a thermometric liquid?
 - When determining the lower fixed point of a mercury-in-glass thermometer, why should the ice be pure?
- In an uncalibrated thermometer, the length of the mercury above the bulb is 22mm at lower fixed point and 134mm at upper fixed point. When the thermometer is placed in a hot liquid, the length of the mercury thread above the bulb is 68mm. Calculate the temperature of the hot liquid.
- When marking the fixed points of a thermometer, it is observed that at 0°C, the mercury level is 1cm and 6cm when at 100°C. Calculate the temperature that would correspond to a length of 4cm.
- In determining the upper fixed point of an unmarked thermometer, why is the hypsometer made with double walls.
 - Why is it that boiling water is not used for sterilization of a clinical thermometer?
 - Why is the range of a clinical thermometer usually 35°C to 42°C?
- A mercury thermometer reads 10°C when dipped into melting ice and 90°C when in steam at normal pressure. Calculate the thermometer reading when it is dipped in a liquid at 20°C.
- The length of mercury column at the lower and the upper fixed points are 2cm and 5cm respectively. Given that the length of mercury at unknown temperature, θ . Determine the value of θ .

HEAT TRANSFER

Heat transfer refers to the flow of heat through matter from a region of high temperature (hot body) to a region of low temperature (cold body).

Modes of heat transfer:

There are three ways by which heat is transferred and these are;

- Conduction.
- Convection.
- Radiation.

CONDUCTION:

This is the transfer of heat through matter from a region of high temperature to a region of low temperature without movement of matter as a whole.

NOTE:

In conduction, heat flows as a result of direct contact of molecules of a substance i.e. heat is transferred when one molecule contacts another molecule.

Therefore, conduction is best in solids (closely packed particles) and worst in liquids and gases (widely spaced particles).

CONDUCTION IN SOLIDS:

Heat transfer in solids occurs a result of;

- Excess energy of vibrations being passed from one atom to another.
- The excess kinetic energy given to the free electrons near the source of heat being carried by these electrons as they move to the colder region.

Explanation of conduction in a metal (solid) using kinetic theory of matter:

When one end of a metal is heated, the temperature of the molecules of the metal near the heat source increases.

The increased temperature increases the kinetic energy of the molecules of the solid thus they begin to vibrate violently. These molecules start to collide with the nearby molecules transferring heat to them. The process continues until heat is transferred to molecules at the other end of the metal.

NOTE:

- ❖ Heat transfer in conduction takes place by vibration of molecules but not actual movement of the heated molecules.
- ❖ Conduction is faster in good conductors than in bad conductors.

Factors that affect the rate of heat in metals:

➤ **Temperature difference between the ends of a metal:**

Heat is transferred quickly when the temperature difference between the ends of the metal is high.

➤ **Length of the metal:**

Much heat is transferred in a short time when the metal bar is short. Therefore, the rate of heat transfer increases when the metal is of smaller length than when the metal is of longer length.

➤ **Cross-sectional area of the metal:**

When the metal is thicker, much heat is transferred in a shortest time than a thin metal at the same time. The rate of heat transfer in metals with large cross-sectional area and vice versa.

➤ **Nature of material of the metal:**

Different materials used to make the metal have different thermal conductivities thus different rates of heat transfer.

Good conductors of heat:

These are materials that allow heat to pass through them easily. i.e. they conduct heat easily.

Examples include;

- All metals e.g. Iron, Aluminium, Copper, Steel etc.

Bad conductors of heat:

These are materials that do not allow heat to pass through them easily. i.e. they don't conduct heat easily.

Examples include;

- All non-metals e.g. Wood, Rubber, Plastics, Glass etc.

Applications (uses) of good and bad conductors of heat:

- Good conductors of heat are used in making of cooking utensils e.g. saucepans, kettles, frying pans, etc.
- Bad conductors of heat are used in making handles of cooking utensils, insulators since they don't allow heat to pass through them.

Question 1:

Explain why a metal feels cold when touched on a cold day.

Since a metal is a good conductor of heat, it conducts all the heat away from the hands. Thus, our hands lose heat and this gives a sensation of coldness.

Question 2:

Explain why a cemented floor feels colder than a carpeted floor.

When we put our feet on a cemented floor, it conducts all the heat away from our feet since it is a good conductor of heat. Therefore, our feet lose heat and become cold.

When we put our feet on a carpeted floor, it doesn't conduct any heat from our feet since it's a bad conductor of heat. Therefore, our feet do not lose heat thus they remain warm.

An experiment to compare conductivities of different solids

QN: Describe an experiment to compare the rate of heat transfer in different conductors.

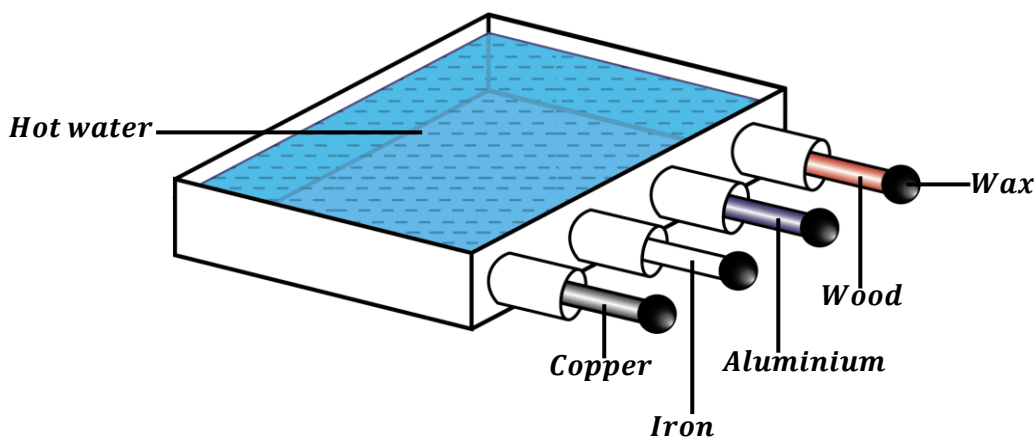

- Identical rods of different materials coated with wax are dipped in hot water.
- After sometime, the wax starts to melt along the rods.
- Wax melts fastest along the copper rod and slowest along the wood rod.
- This shows that copper is the best conductor of heat and wood is the worst conductor of heat.

Experiment to show that wood is a poor conductor of heat:

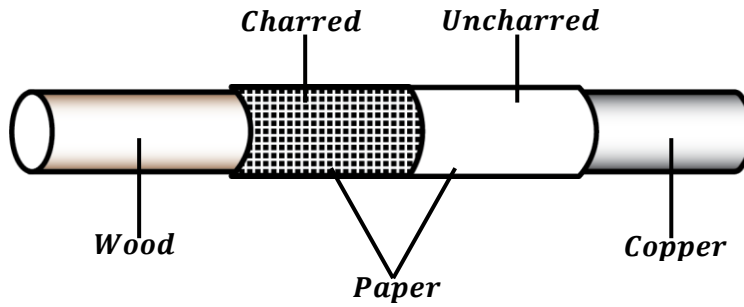

- A composite rod is made by joining a wooden rod with a copper rod.
- A piece of paper is wrapped round the composite rod around the joint so that the wooden and copper rod share the paper equally as shown below.
- The composite rod is passed through a Bunsen burner flame several times.

Observation:

- The part of the paper on the wood gets charred (burnt) while the part of paper on copper remains uncharred (not burnt).

Explanation:

- Copper is a good conductor of heat. Therefore, copper conducts away heat quickly from the paper thus the temperature of part of the paper on it remains low. Hence, the part of the paper on copper does not char.
- Wood is a poor conductor of heat. Therefore, wood does not conduct away heat from the paper thus the temperature of part of the paper on it remains high. Hence, the part of the paper on wood chars.

CONDUCTION IN LIQUIDS AND GASES:

Liquids and gases transfer heat at a very slow rate i.e. they are relatively poor conductors of heat. This is because their molecules are apart.

An experiment to show that water is a poor conductor of heat:

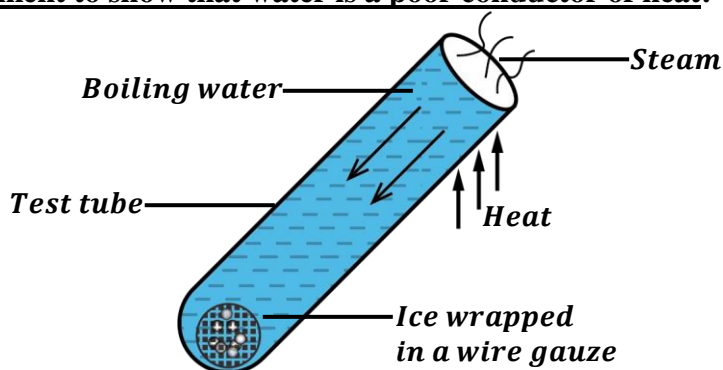

- Ice is wrapped in a wire gauze and then placed in the test tube. The wire gauze is used to keep ice at the bottom of the test tube.
- The test tube is then filled with water.
- The water near the mouth of the test tube is heated.
- It is observed that water at the top starts to boil before the ice at the bottom starts to melt.
- This shows that there is little conduction of heat from the top to the bottom by water hence water is a poor conductor of heat.

An experiment to show that mercury is a better conductor of heat than water:

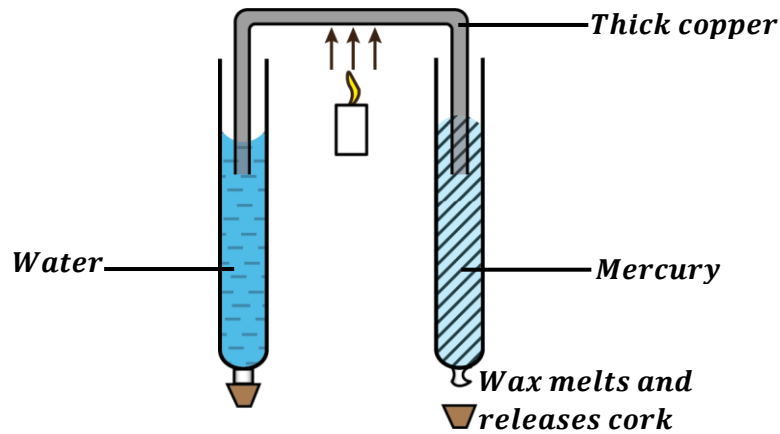

- Two test tubes are filled with equal volumes of water and mercury respectively.
- A cork is attached to the bottom of each test tube.
- A piece of thick copper rod is bent twice at right angles and its ends are put in the test tubes respectively as shown above.
- The centre of the copper rod is heated such that heat is conducted equally into water and mercury test tubes.
- After a short period of time, wax on the mercury-filled test tube melts and the cork falls while that on the water-filled test tube remains attached for a long period of time.
- This shows that heat reaches the wax faster through mercury than in water hence mercury is a better conductor of heat than water.

CONVECTION:

This is the transfer of heat through a fluid from a region of high temperature to a region of low temperature by movement of the fluid itself.

NOTE:

- Convection occurs in only fluids (i.e. liquids and gases) because they can flow easily and cannot occur in solids since they can't flow.
- Convection cannot occur in a vacuum because it requires a material medium.

Explanation of convection in fluids:

When a fluid is heated, it expands and becomes less dense than the surrounding cold fluid. The heated fluid rises upwards and the space left is filled with the surrounding cold fluid. As the warm fluid rises, it gives heat to the surrounding cold fluid thus forming a cyclic movement called **convective currents**.

Definition:

Convective currents are rising and falling fluid caused by a change in temperature and density of a fluid.

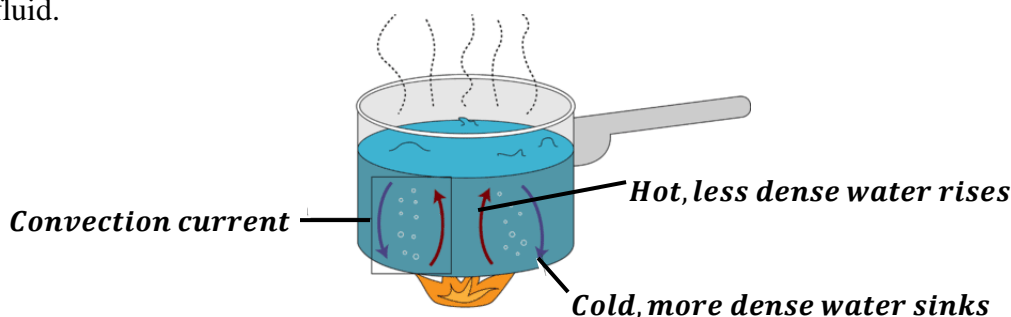

An experiment to show convectional currents in liquids:

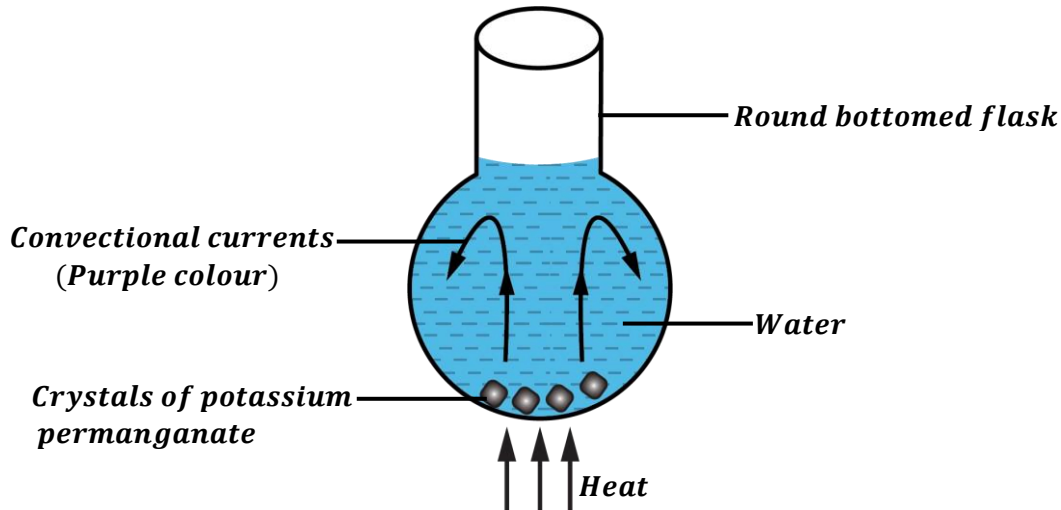

Procedures:

- A round bottomed flask is filled with clean water.
- A few crystals of potassium permanganate are placed at the bottom of the flask using a glass tube.
- The bottom of the flask is gently heated.

Observation:

- It is observed that the purple colour of potassium permanganate is seen moving upwards and on reaching the top, it spreads and then moves downwards forming convectional currents.

Explanation:

- When the solution at the bottom of the flask is heated, it expands and become less dense than the surrounding water thus moving upwards. The surrounding cold and dense water flows to the bottom to replace the risen water.
- So, the water circulates in the flask hence forming convectional currents.

An experiment to show convectional currents in gases:

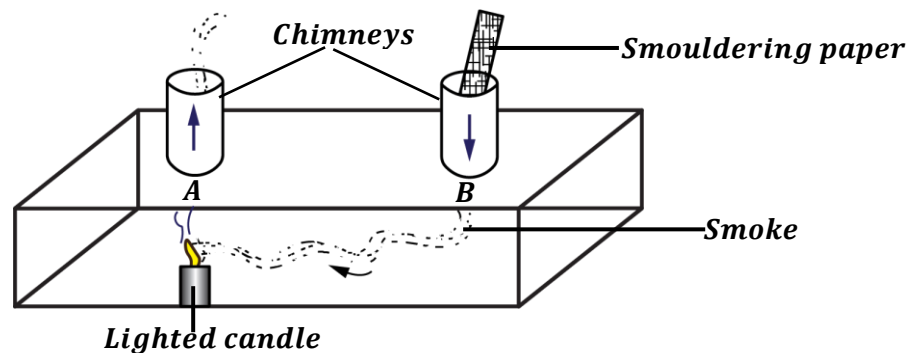

Procedures:

- Fit two glass chimneys to the top of a box with a glass window.
- Light a candle and place it below chimney A.
- Introduce smoke into the box by placing a piece of smouldering paper in the other chimney B.

Observation:

- It is observed that all the smoke from chimney B moves out of the box through chimney A above the candle.

Explanation:

- When the air above the candle is heated, it expands and becomes less dense than the surrounding air thus rises and moves out through chimney A.
- Since the surrounding air (smoke) is cooler and denser, therefore, it sinks into the box through chimney B to replace the risen hot air.
- The difference in densities of the air at the different chimneys sets up a convectional current.

NOTE:

Convection occurs much more readily in gases than in liquids because they expand much more than liquids when heated.

APPLICATIONS OF CONVECTIONAL CURRENTS IN DAILY LIFE
a) Sea breeze:

This is the cool air that blows from sea to land during day time.

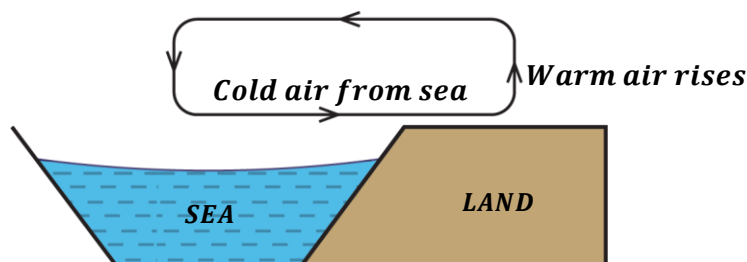

- During day, the land is heated more than the sea by the sun because land is a good absorber of heat and has a lower specific heat capacity than the sea.
- The increase in temperature of land causes the air above the land to expand and become less dense thus rising up.
- The space left by the warm air above the land is filled up by the cold air that blows from sea.
- This results into a sea breeze during day time.

b) Land breeze:

This is the cool air that blows from land to sea at night.

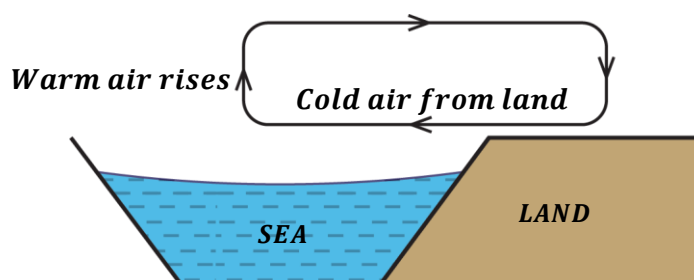

- At night, the land is no longer heated by the sun so it cools very rapidly than the sea since land is a good emitter of heat than the sea. Therefore, the sea is warmer than the land at night.
- The warm air above the sea rises up since it is less dense.
- The space left by the warm air above the sea is filled up by the cold air that blows from land.
- This results into a land breeze at night.

c) Ventilation:

- Air inside a room is heated up on a hot day. This heated air (warm air) expands and becomes less dense thus rising up and flow out through the ventilators.
- The space left by the risen warm air is filled up with fresh cool air which passes through the windows and the doors.
- This results into circulation of air in the room thus forming convectional currents.

Question1:

Explain why ventilators are constructed above the windows and doors.

The ventilators help to move out hot air from the room. Since hot air is less dense than cold air, it rises up and moves out of the room through these ventilators. The cool air which is denser sinks into the room through the windows and doors. This circulation of air helps to cool the room. If the ventilators were put near the floor, the hot air would not leave the room but just stays at the upper part of the room thus keeping the room hot.

Question 2:

Explain how a chimney makes life comfortable in a kitchen.

A chimney helps to drive out smoke and oily-filled air during cooking thus reducing indoor pollution in the kitchen.

During cooking, smoke and some oily-filled air which are denser are produced thus rising up and moves out of the kitchen through the chimneys thus making the kitchen more conducive.

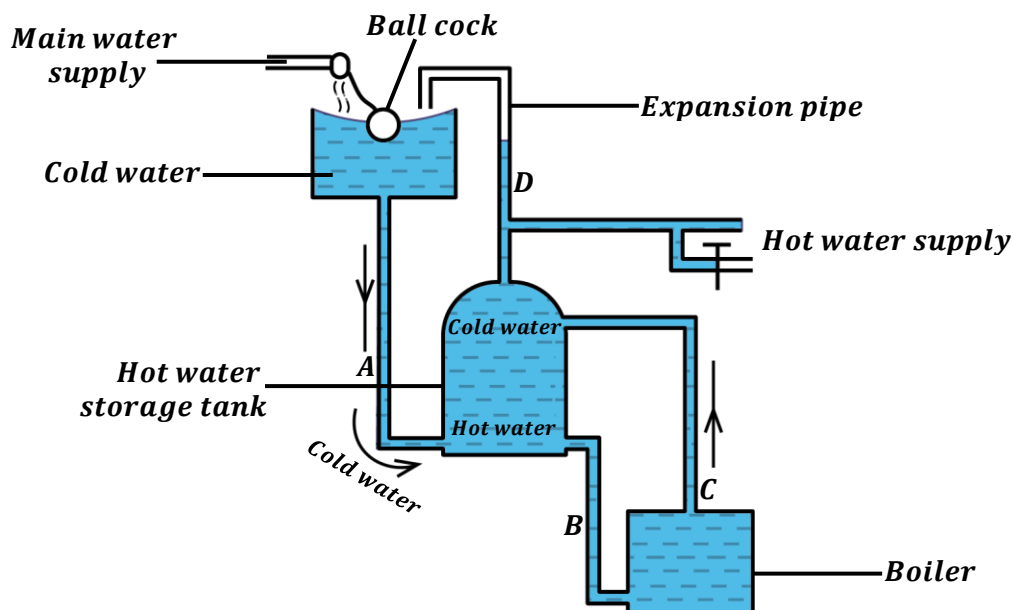
d) Hot water domestic supply system:

- Cold water is supplied to the boiler through the cold-water supply pipes A and B.
- In the boiler, cold water is heated, expands and becomes less dense thus raising up to the hot water storage tank through pipe C. At the same time an equal volume of cold water flows to the boiler through the supply.
- As more cold water is supplied to the boiler, hot water is displaced upwards and supplied to the hot water supply taps.

NOTE:

- ❖ The expansion pipe D allows escape of dissolved air which comes out of the water when it is heated. Therefore, if the expansion pipe is not there, the dissolved air which comes out when water is heated may cause air locks in the pipes thus causing explosion.

- ❖ Pipes A and B are connected to bottom part of hot water storage tank and boiler respectively because they carry cold water which is denser.
- ❖ Pipe C leaves the boiler at the top and enters the hot water storage tank at the top part because it carries hot water which is less dense.

e) **Electric kettles have their heating coil at the bottom:**

The heating coil (element) of an electric kettle is placed at the bottom. Therefore, one can boil any amount of water that can cover the element effectively. Hot water which is less dense than cold water rises above the hot element to the top of the water and the denser cold water sinks down to the hot element. This sets up convection currents which make the water to boil uniformly.

Question: State one difference between convection and conduction.

Conduction:	Convection:
Heat is transferred from a region of high temperature to region of low temperature without the movement of matter as a whole.	Heat is transferred from a region of high temperature to region of low temperature by the movement of fluid itself.

RADIATION:

This is the transfer of heat from one place to another by means of electromagnetic waves.

Since electromagnetic waves do not require a material medium to transfer their energy, therefore radiation does not need a material medium for heat energy to be transmitted.

Examples of heat transfer by radiation include;

- Heat from the sun reaching the earth.
- A hot body or fire losing heat to the surrounding.

NOTE:

- Heat transferred by means of radiation can travel through a vacuum.
- Radiation is the fastest means of heat transfer since it travels at the speed of light.
- The energy from a hot body is called radiant energy.

Factors affecting the rate of heat transfer by radiation:

- Temperature of the body: *A hotter body radiates heat faster compared to a cold body.*
- Surface area of the body: *Bodies with large surface areas (bigger areas) radiate much heat energy per second.*
- Nature of the surface of the body: *Dull surfaces radiate heat energy faster than highly polished surfaces.*

GOOD AND BAD ABSORBERS OF HEAT

<u>Good absorbers:</u>	These absorb most of the heat radiations and reflects less heat energy. Dull and black surfaces absorb most of the heat and reflect a few so they are good absorbers of heat.
<u>Bad absorbers:</u>	These don't absorb most of the heat radiations but reflect most of heat radiations. Shiny or polished surfaces reflect most of the heat radiations so they are bad absorbers of heat.

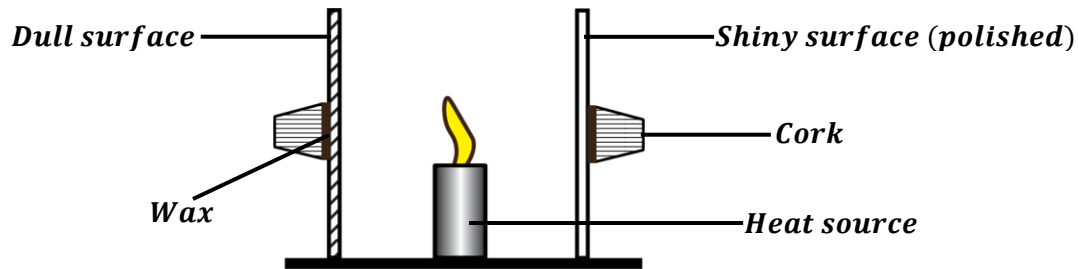
An experiment to show the absorption of radiation in a surface:

Procedures:

- A dull and shiny (polished) surface are placed vertically at a short distance from each other.
- A cork is fixed on the back side of each surface by using wax.
- A heat source is placed mid-way between the two surfaces so that each surface receives the same amount of radiation.

Observation:

- It is observed that the wax on the dull surface melts first and the cork falls off before the wax on the shiny surface melts.

Explanation:

- A dull surface absorbed much heat faster than the shiny surface thus a dull surface is a good absorber of heat radiation than the shiny one. The shiny surface just reflects the heat away from it.

Applications of good and bad absorbers

- ❖ Buildings in hot countries are painted white and roof surfaces are made shiny because white and shiny surfaces are bad absorbers of heat radiation thus keeping the rooms cool.
- ❖ Petrol tanks on vehicles are polished to reflect away radiant heat.
- ❖ White coloured clothes are worn in dry season so that they reflect away heat thus keep us cool
- ❖ Sweaters and blankets are made with dull colours to absorb heat.
- ❖ The bottoms of cooking utensils are made black to absorb heat from the fire.

GOOD AND BAD EMITTERS OF HEAT

Basically, we say that the body emits heat if it can cause the temperature of a nearby body to increase. A body relatively can't emit heat if it can't absorb it.

<u>Good emitters:</u>	These absorb most of the heat radiations and reflects less heat energy. Dull and black surfaces emit most of the heat so they are good emitters of heat.
<u>Bad emitters:</u>	These don't absorb most of the heat radiations but reflect most of heat radiations. Shiny or polished surfaces reflect most of the heat radiations so they are bad emitters of heat.

NOTE:

- ✘ Good absorbers of heat are also good emitters of heat.
- ✘ Bad absorbers of heat are also bad emitters of heat.

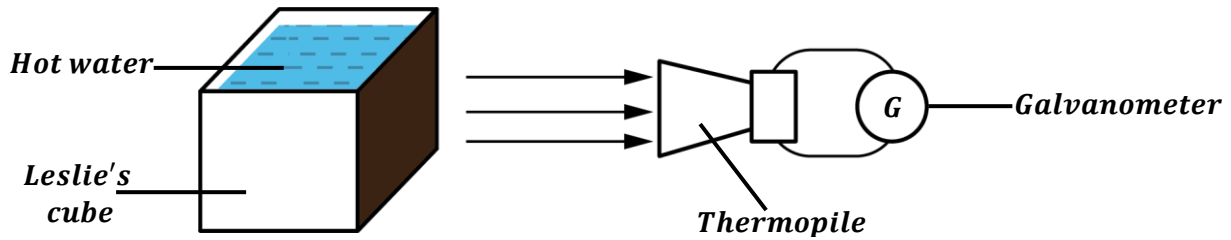
An experiment to show good and bad emitters of heat (radiators of heat)

Procedures:

- A hollow copper cube (Leslie's cube) with each side having a different surface (i.e. black, white and shiny surface) is used.
- The cube is filled with hot water.
- The radiation from each surface is detected by a thermopile and the deflection of the galvanometer observed.

Observation:

- The deflection of the galvanometer is greatest when the thermopile is facing the black surface and least when facing the shiny surface.

Explanation:

- The dull black surface emits a lot of heat radiation than the shiny surface thus a great deflection of the thermopile. Therefore, the dull and black surface is a good radiator or emitter of heat while a shiny or polished surface is a poor emitter of heat radiations.

NOTE:

- ✘ A thermopile is a device which converts heat energy to electrical energy.
- ✘ A galvanometer is a device which measures small currents and small voltages.

Applications of good and bad emitters

- ❖ Tea pots and kettles are polished so that they don't emit heat to the surrounding thus keeping liquids inside hot.
- ❖ Cooling fins on refrigerators are painted black so that they can emit heat quickly to the surrounding.

APPLICATIONS OF RADIATION
a) VACUUM FLASK (THERMOS FLASK):

This is a flask with two silvered walls enclosing a vacuum which keeps its contents at a fairly constant temperature.

The vacuum is designed to either keep hot things hot or cold things cold.

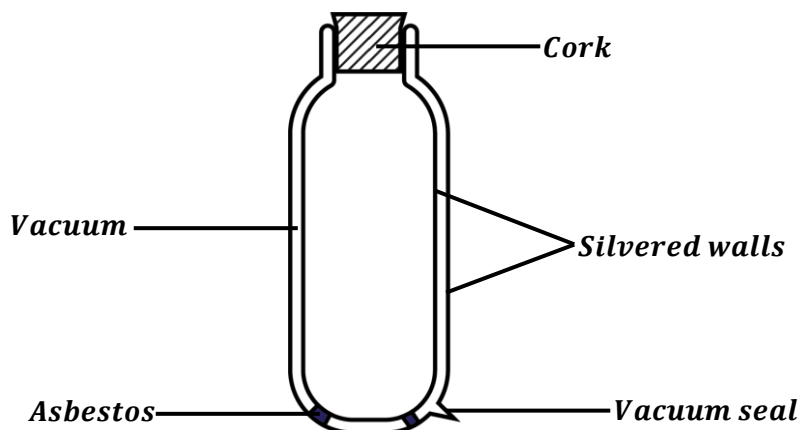

How heat losses are minimised in a vacuum flask:

- ❖ **Cork:** A cork is a poor conductor of heats so it doesn't allow heat to pass through it. Therefore, it minimizes heat loss by conduction.
- ❖ **Vacuum:** A vacuum is a space without air. It minimizes heat loss by convection and conduction.
- ❖ **Silvered surfaces:** These are highly polished surfaces which minimize heat loss by radiation.
Silvered surfaces are poor radiators (emitters) of heat, therefore no heat is allowed to go in and out of the flask.

NOTE:

- ✂ The vacuum seal seals the vacuum. Therefore, if its broken, the vacuum will no longer exist thus causing heat losses through convection and conduction.
- ✂ When the hot liquid is kept in a vacuum flask for a long period of time, it eventually gets cold. This is because little heat is lost at a smaller rate since all flasks are not too perfect whereby some corks may conduct some heat, frequent opening of the flask etc.

b) CHOICE OF DRESSES AND CLOTHES:

On a hot day, a white dress is preferred to a dull dress because it reflects most of the heat radiations that fall on it hence keeping the body cool.

On cold days, a dull or black woollen dress is preferred because it absorbs most of the heat radiations thus retaining it for a longer period of time.

c) GREEN HOUSE EFFECT:

The greenhouse effect is a natural process that warms the Earth's surface. When the radiations from the sun reaches the earth's atmosphere, some it is reflected back and the rest is absorbed by the greenhouse gases in the atmosphere. The greenhouse gases include water vapour, carbon dioxide, ozone and other gases.

After absorbing the radiations from the sun, these greenhouse gases re-radiate these heat radiations to the earth thus warming the atmosphere of the earth's surface.

NOTE:

- ✂ When human activities like land clearing, deforestation, and burning fossil fuels increase, they increase the concentration of the greenhouse gases in the atmosphere thus causing them to absorb more heat from the sun. This increased absorption of heat radiations from the sun leads to excessive warming of the earth. This is called **global warming**.

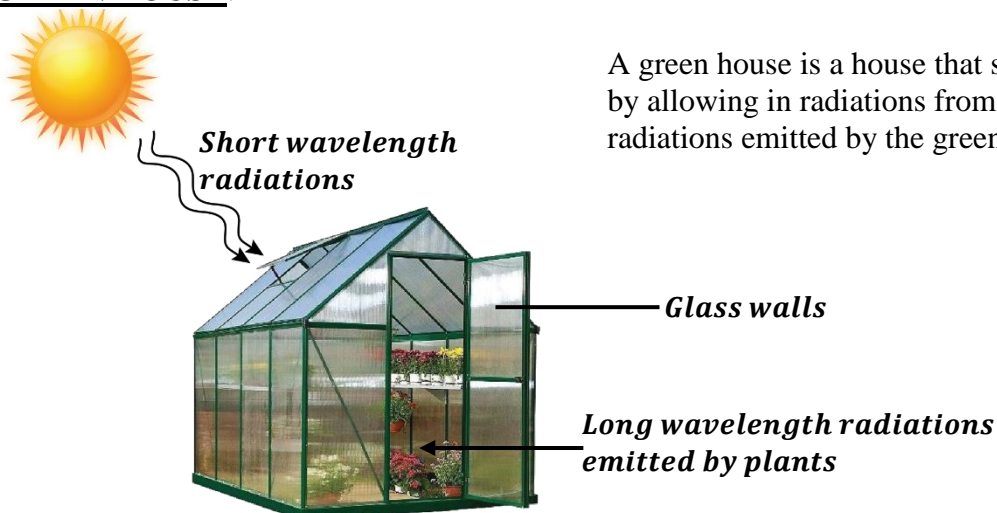
GREEN HOUSE:

How a green house works:

- The sun emits radiations of short wavelength to the earth. These radiations enter the green house through the glass walls.
- The plants and soil in the green house absorb these radiations hence their temperature is raised thus becoming warmer.
- The warm plants and soil in the green house re-radiate (re-emit) radiations of long wavelength.
- Since long wavelength radiations are less penetrative, they are unable to pass through the glass walls of the green house thus causing the temperature inside to continue rising.

EXERCISE:

1.
 - a) Explain why the sea remains cooler than land during daytime and warmer than land at night.
 - b) State two factors that affects the rate of heat transfer along a metallic rod.
 - c) Describe an experiment to show that water is a poor conductor of heat.
2.
 - a) Draw a well labelled diagram of a thermos flask.
 - b) Explain how the features on the thermos flask above enables to keep a liquid warm.
 - c) State two circumstances where the warm liquid in the flask above can get ultimately cold.
3. Explain the following observations;
 - i) A person should crawl on the floor in a smoke-filled room.
 - ii) Ventilators are put near the ceilings of houses.
 - iii) Houses in North-African countries like Egypt are painted white.
 - iv) Flames of fire move upwards.
4.
 - a) Distinguish between Conduction and radiation.
 - b) Explain why the metallic blade of the knife feels cold on a cold day.
 - c) Describe an experiment to show that wood is poor conductor of heat than copper.
5.
 - a) Explain why a black coat is usually worn on a cold otherwise not on a hot day.
 - b) In an experiment to demonstrate the poor conductivity of water, ice is wrapped in a wire gauze. Explain why this is so.
6.
 - a) Define the term radiation.
 - b) Explain how a vacuum flask is able to keep a cold liquid cool for a long period of time.
 - c) Explain how global warming occurs in the earth's atmosphere.
7. Explain the following observations;
 - i) Blankets are made of dull colours.
 - ii) Car radiators are coiled and painted black.
 - iii) A swimmer prefers to put on a wet cloth when diving in cold water.
8.
 - a) Define the term good emitter of radiation.
 - b) Describe how a green house is able to support plant growth.
9.
 - a) Explain the greenhouse effect and how it affects the earth's atmosphere.
 - b) Explain why solar panels are painted black.
10.
 - a) Describe an experiment to show convection in liquids.
 - b) Explain why electric kettles have their heating element at the bottom.

THERMAL EXPANSION OF MATTER

All the three states of matter (solids, liquids and gases) change in volume when heated

Definition:

Expansion is the increase in size of matter whenever matter is heated.
This increase in size of an object occurs in all directions.

Definition:

Contraction is the decrease in size of matter whenever matter is cooled.

EXPANSION IN SOLIDS

All solids expand when heated. Some solids expand greatly and others very little.

An experiment to demonstrate thermal expansion in solids:

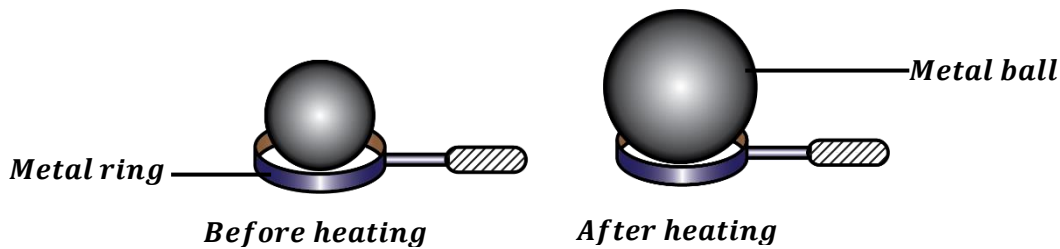

- A metal ball which just passes through the metal ring is used.
- The metal ball is heated for some time.
- It is observed that after heating the ball, it could not pass through the metal ring. This is because the ball has expanded when heated.
- When the metal ball is cooled, it passes through the metal ring again. This indicated that on cooling, the metal ball had contracted.

APPLICATIONS OF THERMAL EXPANSION

Thermal expansion in solids is applied in the following;

a) Bimetallic strip:

This is a strip made when two metals of different expansion rates are joined together e.g. Brass and Iron.

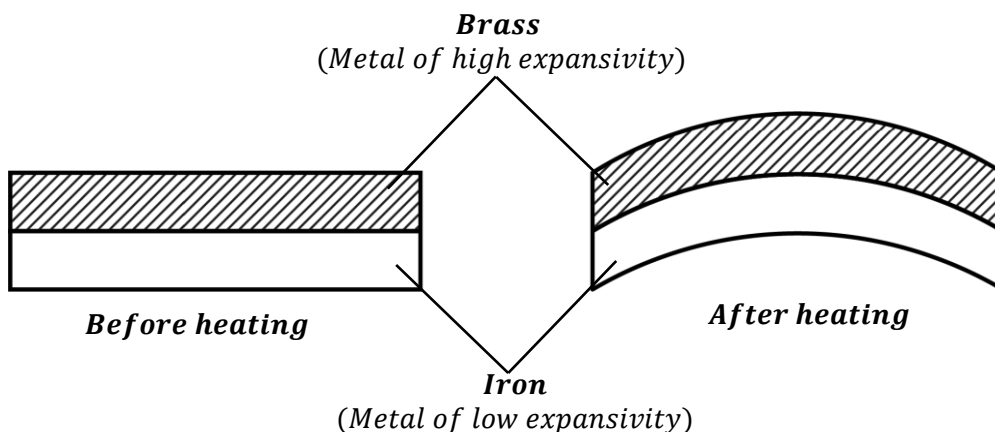

When a bimetallic strip is heated, it forms a curve with a metal that expands more on the outside and the metal that expands less on the inside.

Uses of bimetallic strips:

- They are used in ringing bells of fire alarms.
- They are used in thermostats in electrical appliances.

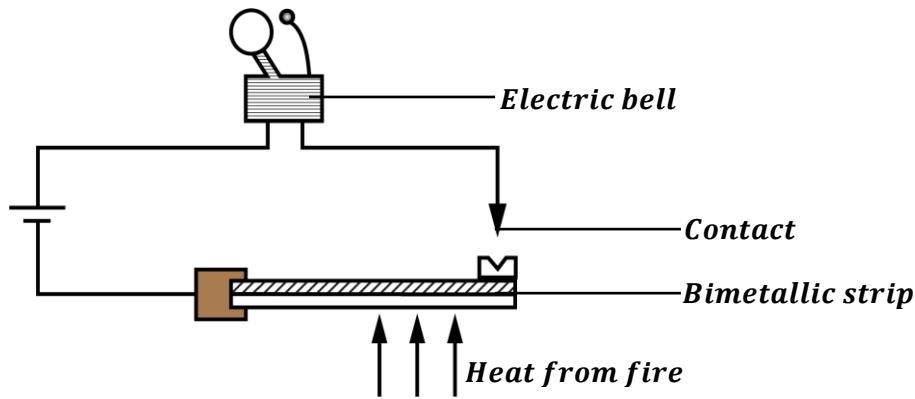
Fire alarms:

- When there is a fire outbreak in a room, the bimetallic strip is heated by fire. This causes it to bend outwards thus completing the electrical circuit.
- When the circuit is complete, current flows to the electric bell thus causing it to ring.

Thermostats:

A thermostat is a device that keeps the temperature of a room or an electrical appliance to remain constant.

Thermostats are used in the heating circuits of electric flat irons.

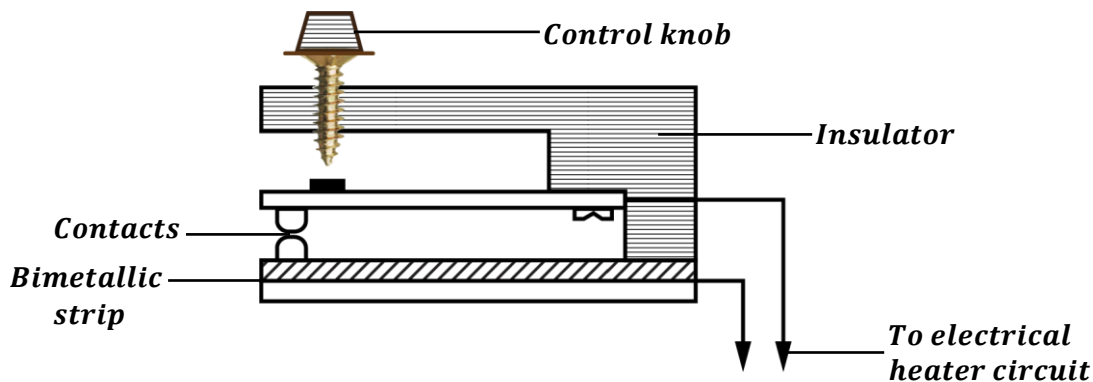

- The control knob is set to the required temperature.
- On reaching the required temperature, the bimetallic strip bends away thus breaking the circuit at the contacts. This switches off the heater.
- On cooling, the bimetallic strip makes returns back to its original shape and makes contact again thus completing the circuit. This switches on the heater.

Other applications of thermal expansion (Disadvantages of expansion):
b) Bridges:

Girders in bridges are made of mainly steel. During cold days bridges contract and during hot days, the bridges expand. In order to allow room for expansion and contraction in bridges, the bridge is constructed with one end fixed and the other end placed on rollers. This helps it contract and expand freely without damaging the bridge.

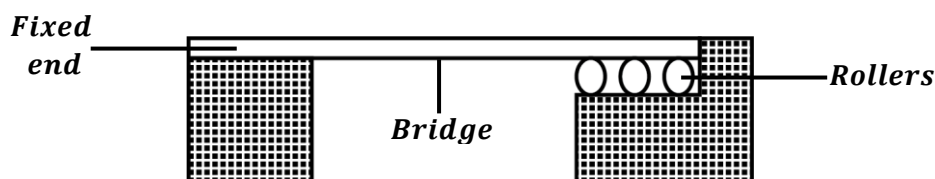

c) Railways:

On a hot day, the rails are heated and they are bent due to expansion. This causes them to get seriously damaged.

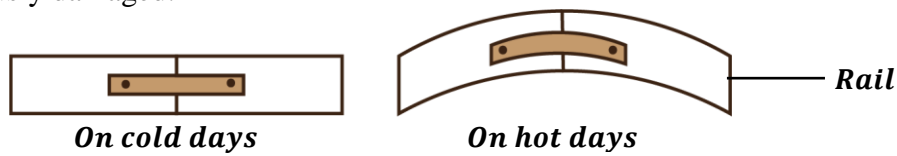

In order to give room for expansion during hot days, railway lines are constructed with gaps between the rails.

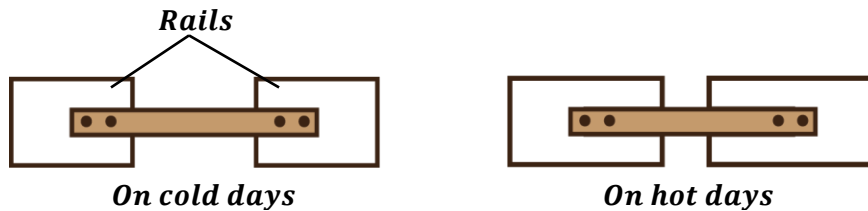

d) Transmission wires:

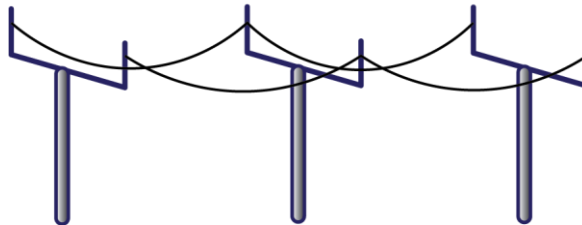
The wires used in transmission of electricity and telephone cables are loosely fixed (sag) in order to allow them expand freely during hot days and contract freely during cold days.

e) Rivets:

Rivets are tight joints obtained by riveting two metals together.

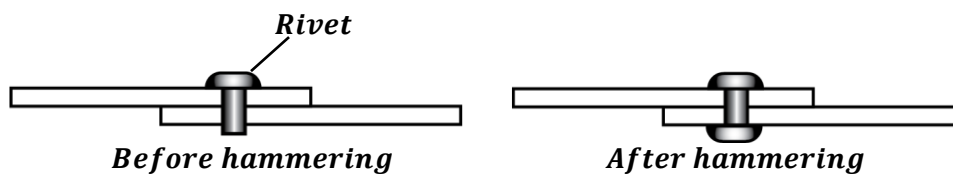
A hot rivet is pushed through a hole between two metals to be joined together and its end is hammered flat. On cooling, it contracts and pulls the two metals together.

LINEAR EXPANSIVITY OF A METAL:

When a metal is heated, its length increases after expansion and this increase in length is called linear expansion. We distinguish between the rates of expansion of different metals by finding their linear expansivities (coefficient of linear expansion).

Definition:

Linear expansivity of a material is the fraction of its original length which increases when its temperature rises by 1K.

Therefore, linear expansivity depends on;

- Length of a material.
- Rise or change in temperature.
- Nature of material

$$\text{Linear expansivity} = \frac{\text{Change in length (Linear expansion)}}{\text{Original length} \times \text{Change in temperature}}$$

$$\alpha = \frac{\Delta L}{L_0 \times \Delta \theta}$$

Where;

$$\Delta L = L_1 - L_0 \text{ (New length - Original length)}$$

$$\Delta \theta = \theta_1 - \theta_0 \text{ (Final temperature - Initial temperature)}$$

The SI unit of linear expansivity is K^{-1} or $^{\circ}C^{-1}$.

Examples:

1. The length of a metal rod is 800mm. It is found to increase to 801.36mm when heated from $15^{\circ}C$ to $100^{\circ}C$. Calculate the linear expansivity of the metal rod.

$$L_0 = 800\text{mm}, \quad L_1 = 801.36\text{mm}, \quad \Delta L = (801.36 - 800) = 1.36\text{mm}$$

$$\theta_0 = 15^{\circ}C, \quad \theta_1 = 100^{\circ}C, \quad \Delta \theta = (100 - 15) = 85^{\circ}C$$

$$\alpha = \frac{\Delta L}{L_0 \times \Delta \theta}$$

$$\alpha = \frac{1.36}{800 \times 85}$$

$$\alpha = 0.00002 /^{\circ}C$$

2. Calculate the linear expansion (change in length) of aluminium cable 50m between two electric poles when its temperature rises by $40^{\circ}C$. The linear expansivity of aluminium is $2.6 \times 10^{-5}^{\circ}C^{-1}$.

$$L_0 = 50\text{m}, \quad \Delta L = ?$$

$$\Delta \theta = 40^{\circ}C, \quad \alpha = 2.6 \times 10^{-5}^{\circ}C^{-1}$$

$$\alpha = \frac{\Delta L}{L_0 \times \Delta \theta}$$

$$2.6 \times 10^{-5} = \frac{\Delta L}{50 \times 40}$$

$$\Delta L = 50 \times 40 \times 2.6 \times 10^{-5}$$

$$\Delta L = 0.052\text{m}$$

3. A metal rod has length of 100cm at $200^{\circ}C$. At what temperature will its length be 99.4cm if the linear expansivity is $0.00002 K^{-1}$?

$$L_0 = 100\text{cm}, \quad L_1 = 99.4\text{cm}, \quad \Delta L = (99.4 - 100) = -0.6\text{cm}$$

$$\theta_0 = 200^{\circ}C, \quad \theta_1 = ?, \quad \alpha = 0.00002 K^{-1}$$

$$\alpha = \frac{\Delta L}{L_0 \times \Delta \theta}$$

$$0.00002 = \frac{-0.6}{100 \times \Delta \theta}$$

$$\Delta \theta = \frac{-0.6}{100 \times 0.00002}$$

$$\Delta \theta = -300^{\circ}C$$

$$\Delta \theta = \theta_0 - \theta_1$$

$$300 = 200 - \theta_1$$

$$\theta_1 = (200 - 300)$$

$$\theta_1 = -100^{\circ}C$$

4. A steel bridge is 2.5m long. If the linear expansivity of steel is $1.1 \times 10^{-5} K^{-1}$, how much will it expand when temperature rises by $5^{\circ}C$?

$$L_0 = 2.5m, \quad \Delta L = ?$$

$$\Delta\theta = 5^{\circ}C, \quad \alpha = 1.1 \times 10^{-5} K^{-1}$$

$$\alpha = \frac{\Delta L}{L_0 \times \Delta\theta}$$

$$1.1 \times 10^{-5} = \frac{\Delta L}{2.5 \times 5}$$

$$\Delta L = 2.5 \times 5 \times 1.1 \times 10^{-5}$$

$$\Delta L = 0.0001375m$$

EXERCISE:

- Calculate the new length of the metal given that its new length is 50cm when heated from $0^{\circ}C$ to $25^{\circ}C$. (α for metal is $1.8 \times 10^{-5} /^{\circ}C$).
- A metal rod is 64.5cm long at $12^{\circ}C$ and 64.6cm at $90^{\circ}C$. Find the coefficient of linear expansion, (α) of its material.
- A rod is found to be 0.04cm longer at $30^{\circ}C$ than it was at $10^{\circ}C$. Calculate its length at $10^{\circ}C$ if the linear expansivity is $2.0 \times 10^{-5} /^{\circ}C$.
- The length of iron rod is $100^{\circ}C$ is 300.36cm and at $150^{\circ}C$ is 300.54cm. Calculate its length at $0^{\circ}C$.

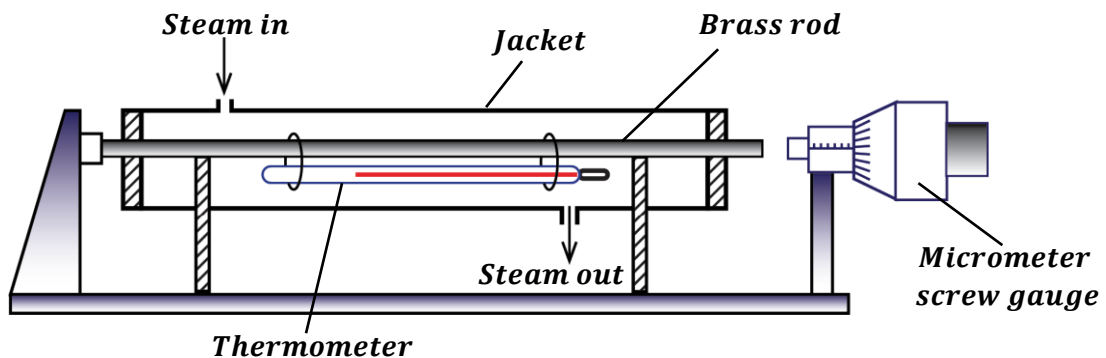
An experiment to measure the linear expansivity of a metal:

- The original length, L_0 of the brass rod is measured using a metre rule.
- The brass rod with a thermometer is placed in a steam jacket.
- The micrometer screw gauge is screwed up so that there is no gap at either ends of the brass rod. The reading, l_1 of the micrometer screw gauge is recorded.
- The initial temperature of the brass rod, θ_1 is recorded.
- The micrometer screw gauge is unscrewed to leave room for expansion of the brass rod.
- The steam is passed through the jacket for a few minutes.
- The micrometer screw gauge is screwed up again so that there is no gap at either ends of the brass rod. The reading, l_2 of the micrometer screw gauge is recorded.
- The final temperature of the brass rod, θ_2 is recorded.
- Then linear expansivity of the metal is got from;

$$\text{Linear expansivity} = \frac{(l_2 - l_1)}{L_0 \Delta\theta}$$

EXPANSION IN LIQUIDS:

Liquids expand when heated. Different liquids have different expansion rates when equally heated. Liquids expand more than solids since their molecules are far apart compared to those of solids thus their intermolecular forces are weak.

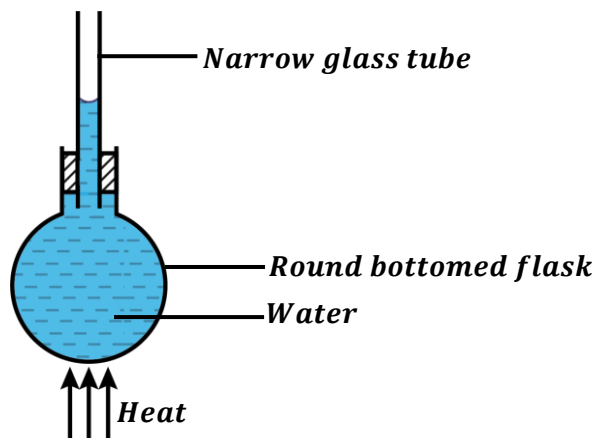
An experiment to demonstrate expansion of a liquid e.g. water:

Procedure:

- The flask is completely filled with coloured water.
- A narrow glass tube is passed through the hole of the cork and the cork is fixed tightly into the flask.
- The initial level of water in the narrow glass tube is observed.
- The bottom of the flask is then heated.
- The new level of water in the narrow glass tube is observed.

Observation:

It is observed that the level of water in the narrow glass tube first falls and then starts to rise again.

Explanation:

- When the flask is heated, the flask gets heated first before the heat is passed to the water inside it. Therefore, the flask expands first and increase in volume before the water causing a fall in the water level.
- However, when the heat reaches the water, it expands and increase in volume thus its level starts to rise in the narrow tube.

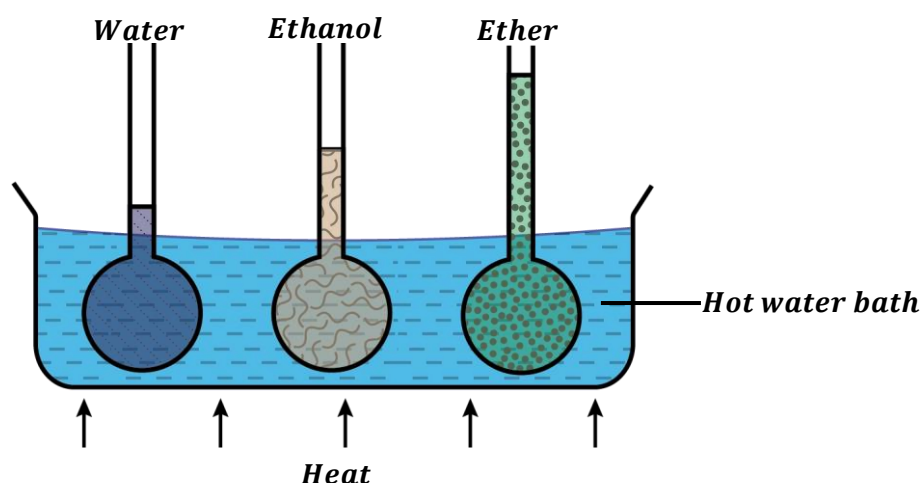
An experiment to compare the expansions of different liquids:

- Three identical glass flasks are filled with water, ethanol and ether respectively to the same level.
- The glass flasks are heated by placing them in hot water which is maintained at the same temperature.
- It is observed that after some time, the liquid levels rise to different levels. This shows that different liquids expand differently for the same temperature change.
- It is also observed that ether expands more than ethanol and water.

ANOMALOUS (ABNORMAL) EXPANSION OF WATER

Liquids expand steadily when heated i.e. when their temperature increases.

Water has an abnormal behaviour whereby when its temperature rises from 0°C to 4°C , it contracts instead of expanding. This situation is referred to as the **anomalous expansion of water**.

Definition:

Anomalous expansion of water is the abnormal behaviour of water whereby it contracts instead of expanding when its temperature rises from 0°C to 4°C .

Volume against temperature graph showing expansion of water

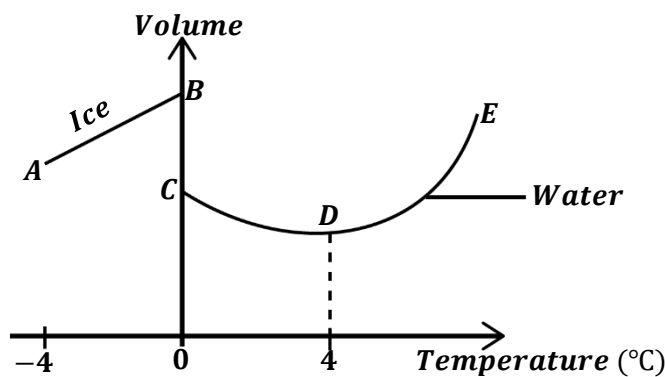

AB: As ice is heated, it expands until when its temperature reaches 0°C where it melts to form water.

BC: Ice melts to form water at 0°C .

CD: As the temperature rises, the water 0°C contracts until 4°C .

DE: As the temperature exceeds 4°C , water starts to expand steadily.

From the graph, water has its minimum volume at 4°C . Thus, the density of water is maximum when the temperature is 4°C .

Density against temperature graph showing expansion of water

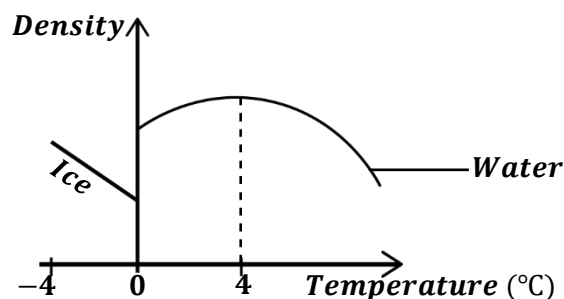

From the graph, the density of water is maximum at 4°C .

NOTE:

- ✂ At 0°C, the volume of ice is greater than the volume of water. Therefore, the density of ice is less than the density of water. This explains why ice floats when mixed with water.

Question: Explain why ice floats on water.

This is because for a given mass of ice at 0°C, its volume is always greater than the volume of water. Therefore, the density of ice is always less than the density of water thus causing it to float on water.

Biological importance of anomalous expansion of water

QN: Explain how anomalous expansion of water helps to preserve the lives of aquatic animals.

Preserving aquatic life in ponds and lakes:

The effect of anomalous expansion of water is that the coldest water always floats on top of the surface of the other water since it is less dense.

Since water at 4°C is the heaviest (denser), this water settles at the bottom of the lake and the lightest (less dense) water settles at the top layer of the lake.

During winter, the water at the top is the first to freeze to ice. Since ice is a poor conductor of heat, it insulates the rest of the water below it from the coldness of the winter.

This helps to preserve the lives of aquatic animals in water.

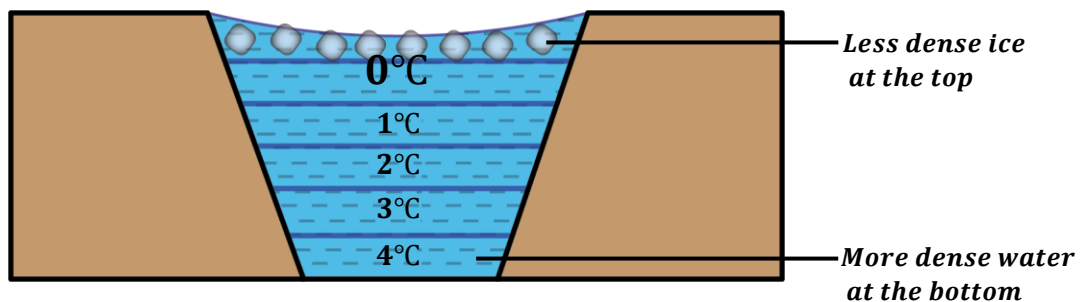

NOTE: Anomalous expansion also helps in weathering of rocks.

Disadvantages of the abnormal expansion of water:

- It prevents water from being used as a thermometric liquid.
- It causes the bursting of water pipes when water flowing through them freezes.

EXPANSION IN GASES

When a gas is heated, the gas molecules gain more energy and move further apart thus occupying more space. Therefore, gases expand more than the liquids and solids since their molecules are widely spaced and their intermolecular forces are very weak.

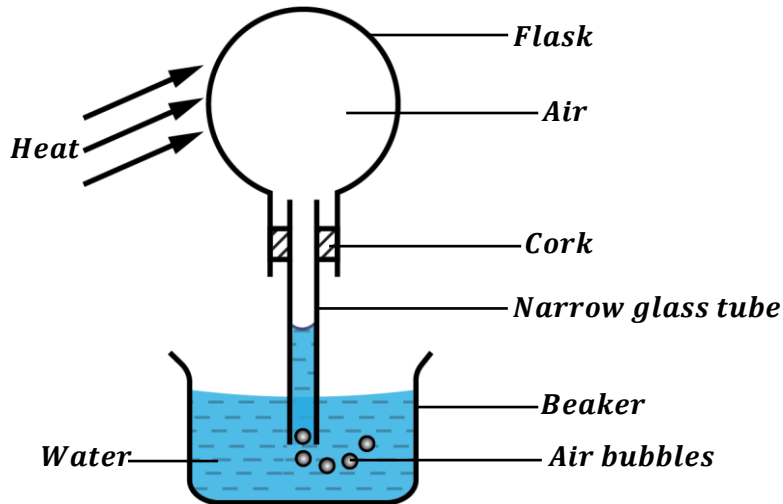
An experiment to show expansion in gases:

- Water is poured in a beaker.
- A narrow glass tube is passed through the hole of the cork and the cork is fixed tightly into the flask.
- The flask is then inverted and dipped in the beaker filled in water.
- The flask is then gently heated.
- It is observed that level of water in the narrow glass tube falls and air bubbles are seen coming out from the other end of the tube. This shows that air expands when heated and pushes the water in the tube downwards.
- On cooling the flask, air in the flask contracts and water rises up in the narrow glass tube since more space has been created in the flask.

APPLICATIONS OF EXPANSION IN GASES:

It is applied in;

Hot air balloons:

When air in the balloon is heated, it expands and becomes less dense thus rising.



EXERCISE:

1. a) Explain why gases expand much more than solids for the same temperature change.
b) State and explain the advantages and disadvantages of anomalous expansion of water.
2. The figure below shows a strip of copper and iron bonded together.



- a) Redraw the diagram to show what happens when the strip is heated.
- b) Why does the change you have shown in (a) above take place?
3. a) Define the following terms;
 - i) Contraction of a material.
 - ii) Expansion of a material.
- b) Describe an experiment to demonstrate expansion and contraction in solids.
- c) State any one application of expansion in solids.
4. a) Describe an experiment to show expansion in liquids.
c) Explain anomalous expansion of water and give its importance to aquatic life.
5. Air was trapped in a round bottomed flask as shown below. The flask is inverted in a beaker of water and then gently heated.

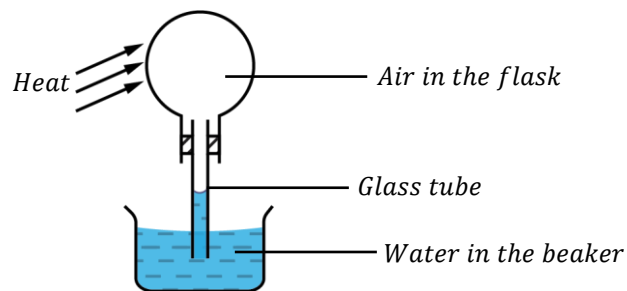

- a) State what was observed when the flask is heated.
- b) Explain your observation in (a) above.
6. Two flasks with a mercury manometer are arranged as shown in the figure below. Flask A is painted black while flask B is polished white. A flame is then placed midway between them.

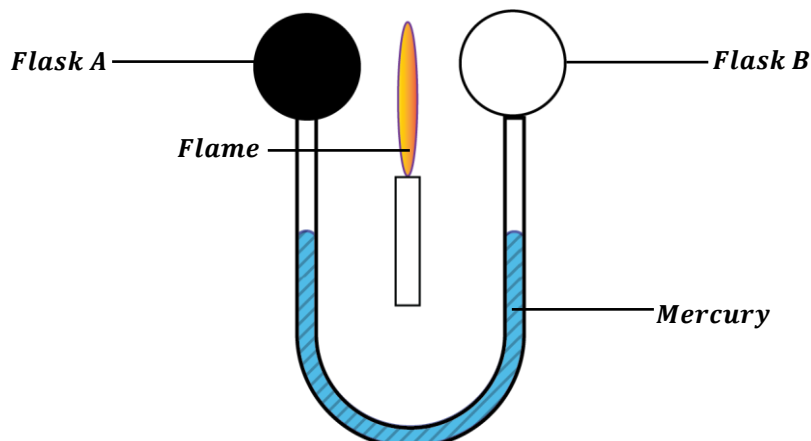

- a) State what is observed.
- b) Explain your observation.

ELECTRO-MAGNETISM

MAGNETIC EFFECT OF AN ELECTRIC CURRENT:

When current flows in a wire, a magnetic field is created around the wire.

The direction of magnetic field created is determined by the direction of current.

- ❖ If a straight vertical wire passing through the center of a card board held horizontally with iron fillings and current is passed through the wire, iron fillings sprinkled on the card board make concentric circles when the board is tapped.

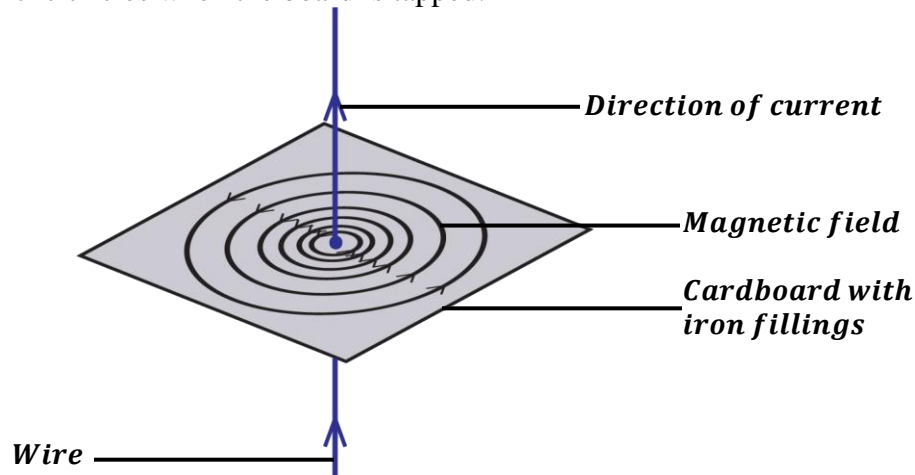

Experiment to show magnetic effect of an electric current using a compass needle.

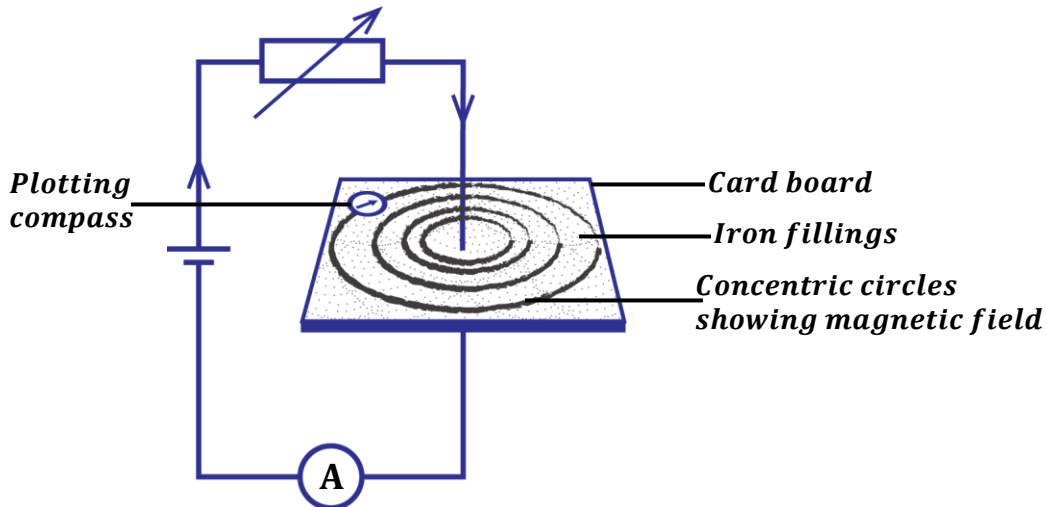

- A card board is held horizontally with a vertical copper wire passing through the centre of the card board.
- Iron fillings are sprinkled all over the card board and current is switched on.
- The card board is tapped and the iron fillings arrange themselves in series of concentric circles. This shows that a magnetic field has been created around the wire.
- A plotting compass is placed at different positions around the wire on the card board to determine the direction of magnetic field.



NOTE: The concentric circles are close to each other near the wire showing that magnetic force is stronger near the wire.

DIRECTION OF MAGNETIC FIELD AND CURRENT

The direction of the magnetic field around the wire can be determined by the following rules.

Right hand grip rule:

It states that if a wire is held in the right hand with the thumb pointing in the direction of current then the other fingers point in the direction of magnetic field.

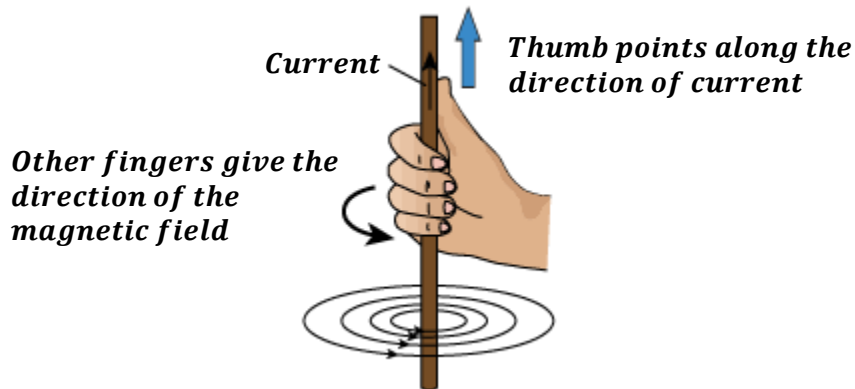

Maxwell's cork-screw rule:

It states that if the right hand is used to screw a screw a cork-screw along the wire in the direction of current, the direction of rotation of the screw gives the direction of magnetic field.

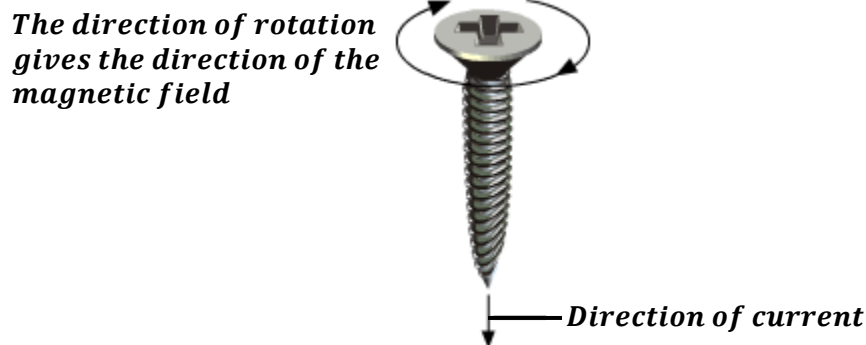

MAGNETIC FIELD PATTERN DUE TO A STRAIGHT WIRE CARRYING CURRENT.

(a) **Straight wire carrying current into a paper:**

We use a cross 

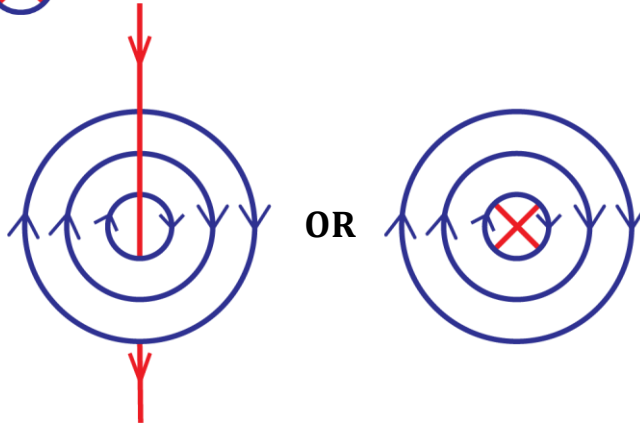

(b) **Straight carrying current out of paper:**

We use a dot 

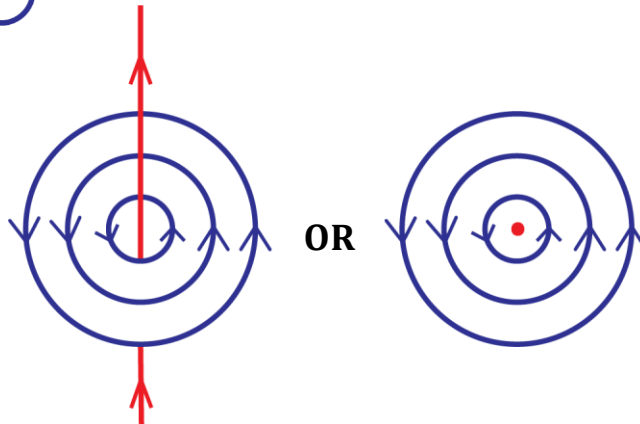

(c) **Two straight wires carrying current in the same direction:**

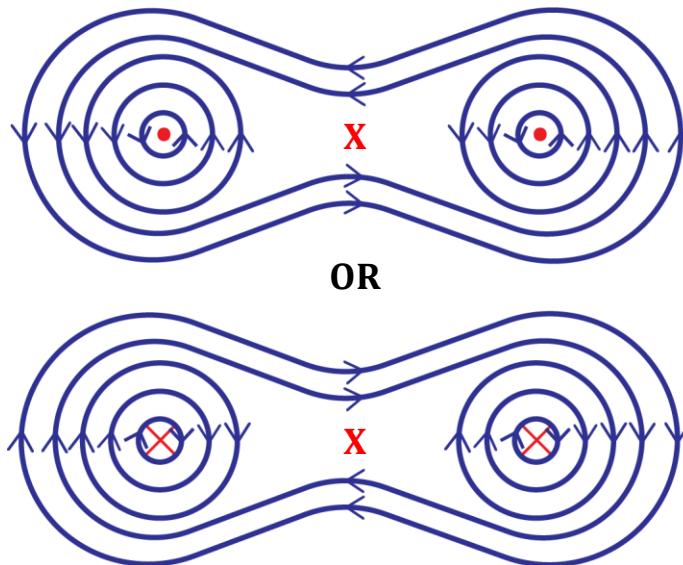

(d) Two straight wires carrying current in opposite directions:

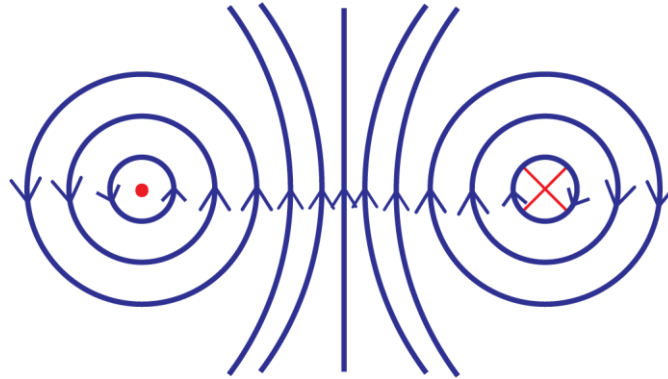

(e) Current due to a circular coil:

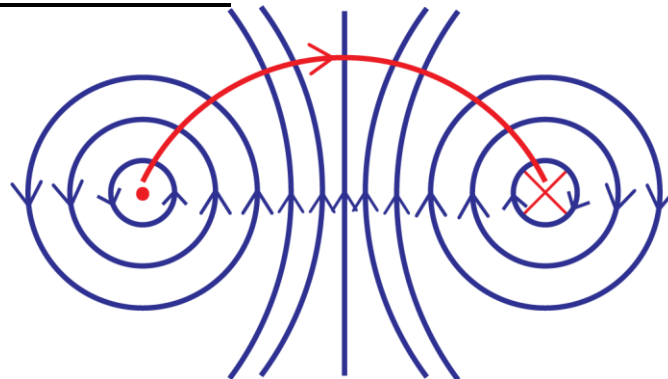

(f) Current due to a circular coil:

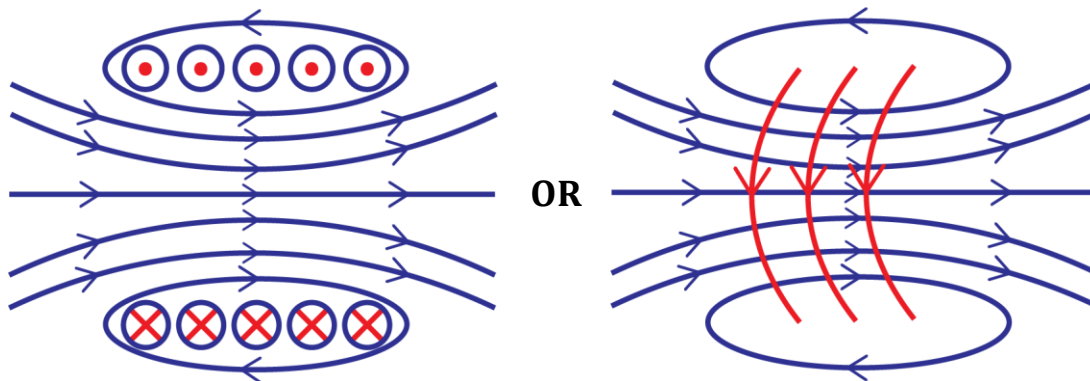

ELECTRO-MAGNETS

If a piece of iron is placed inside a solenoid, it becomes strongly magnetized when the current is flowing. When current is switched off, the iron loses its magnetism. Such a device is called an electromagnet.

Definition:

An electromagnet is a magnet produced when a magnetic material is placed in a solenoid carrying current.

Factors that affect the strength of an electromagnet:

- ❖ **Number of turns of the solenoid:**
Increasing the number of turns of the solenoid increases the strength of the electromagnet.
- ❖ **Amount of current flowing in the solenoid:**
Increasing the current flowing in the solenoid increases the strength the electromagnet.
- ❖ **Nature of magnetic material used:**
If soft iron is used, it has much strength because iron is easily magnetized and easily demagnetized.
- ❖ **Shape of magnetic material used:**
If the poles of the magnetic material are close to each other the electromagnet produced is stronger. A horse-shoe magnet produces a stronger electromagnet.

APPLICATIONS OF ELECTROMAGNETS

Electromagnets are frequently used in the following devices.

- Lifting magnets.
- Electric bells.
- Telephone receiver.
- Moving coil loud speaker.
- Magnetic relays.

LIFTING MAGNETS:

In steel industries, electromagnets are used for lifting and transporting heavy steel from one place to another in a factory.

The electromagnets are made of several coils of an insulated copper wire wound on a U-shaped soft iron so that an opposite polarity is produced.

The opposite adjacent poles increase the lifting power of the electromagnet.

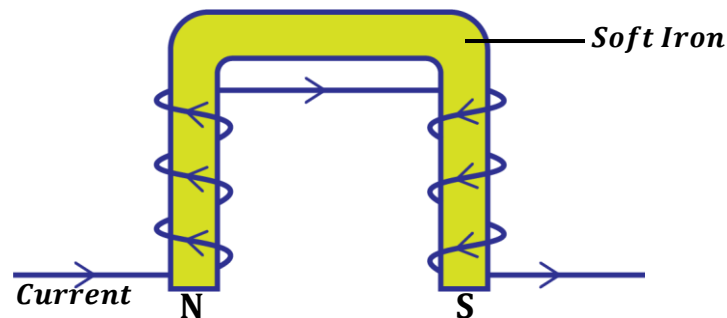

ELECTRIC BELL:

Structure:

It consists of a hammer, a gong, soft iron armature, contact adjusting screw, a push switch, steel spring and an electromagnet made of two coils wound in opposite directions on the iron cores.

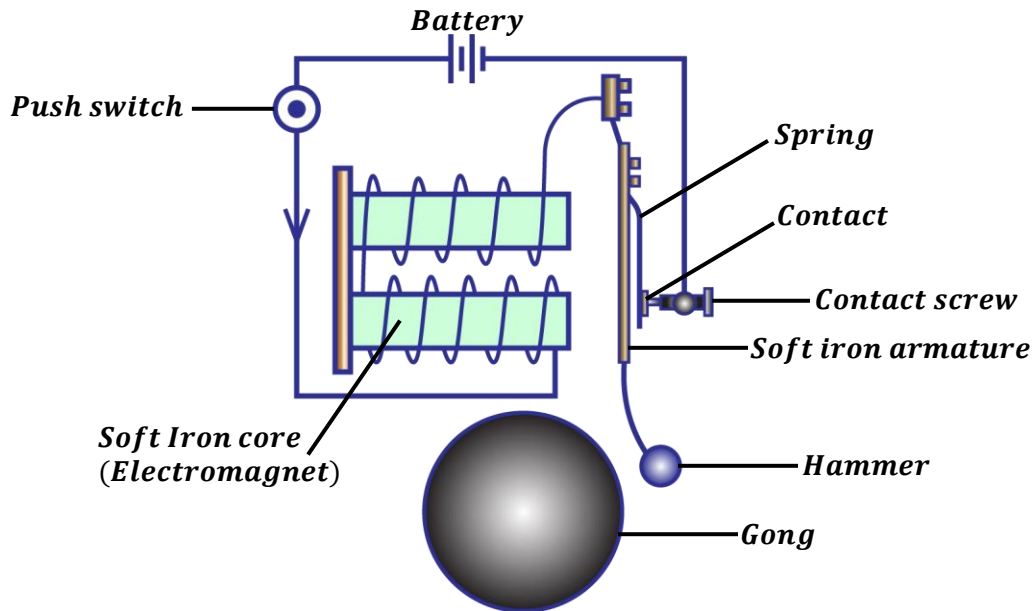

Mode of operation of an electric bell:

- When the switch is pressed, current flows in the circuit and magnetizes the soft iron core which becomes an electromagnet.
- The electromagnet attracts the soft iron armature which makes the hammer to hit the gong and a loud sound is heard.
- As the armature is attracted, the contact between the spring and the contact screw is broken thus cutting off the current.
- The electromagnet loses its magnetism and the spring returns back to its original position and makes the contact again.
- The process is repeated and the hammer hits the gong repeatedly making continuous ringing.

TELEPHONE RECEIVER (EAR PIECE):

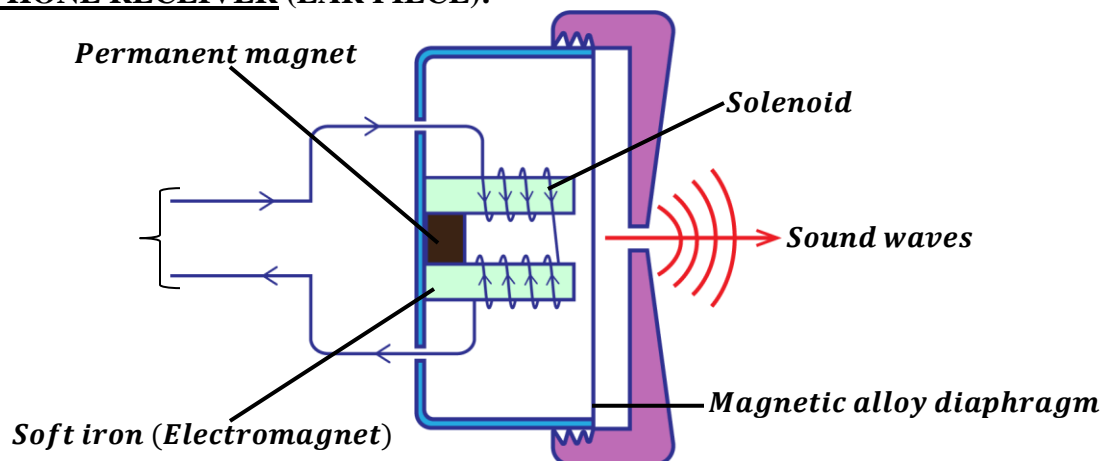

- When a person speaks into a telephone microphone, sound energy is converted into electric current. The current produced is varying and has the same frequency as the sound from the person.
- When the current passes through the solenoid in the telephone receiver, the soft iron (electromagnet) is magnetized.
- The electromagnet produces a corresponding variation in the pull of the diaphragm.
- The diaphragm then vibrates and reproduces a copy of the sound produced by the person through the microphone.



MAGNETIC RELAY:

A magnetic relay is a switch which uses a small current in a primary circuit to turn on or off a larger current in the secondary circuit.

They are used in telephone circuits, traffic light circuits etc.

Mode of operation of a magnetic relay:

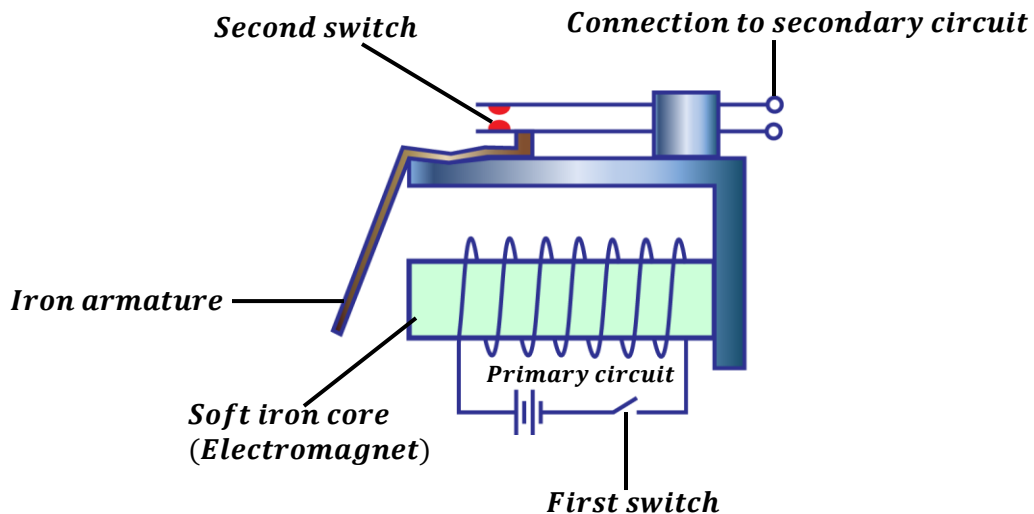

- The primary circuit supplies current to the soft iron (electromagnet).
- The soft iron gets magnetized and it then attracts the iron armature.
- As the armature is attracted, the contacts of the second switch are closed and current flows to the secondary circuit.
- When current in the primary circuit is switched off, the electromagnet loses its magnetism. This makes the iron armature to return back to its original position thus making the contacts of the second switch to become open again



CIRCUIT BREAKER:

This is an automatic switch that cuts off current in the circuit when current become too much.

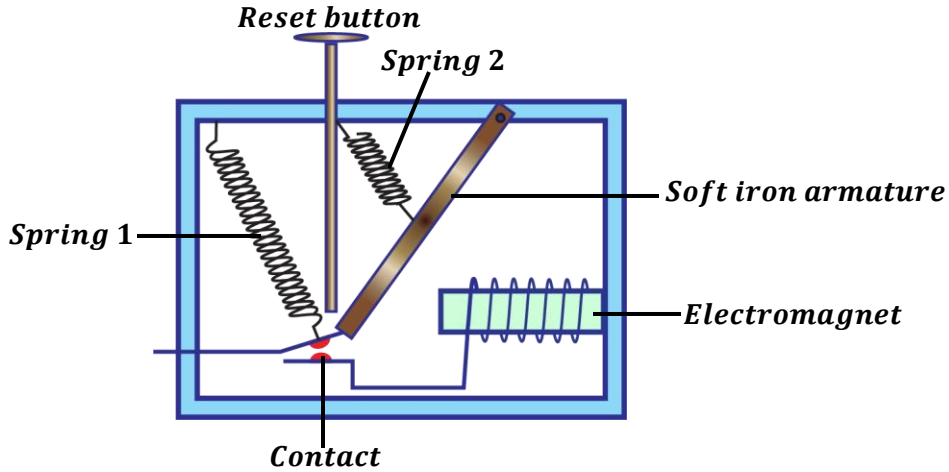

When current in the circuit increases, the strength of the electromagnet will also increase thus pulling the soft iron armature towards the electromagnet. As a result, spring 1 pulls the contact apart and disconnects the circuit immediately and current stops to flow. The circuit can be reconnected back using a reset button by pushing down in order to bring the contacts together.

**FORCE ON A CONDUCTOR CARRYING CURRENT IN A MAGNETIC FIELD
(MOTOR EFFECT)**

When a conductor carrying current is placed across a magnetic field, it experiences a force

How a force on a current carrying conductor occurs:

A magnetic field exists around a conductor carrying current. Therefore, when a conductor carrying current is placed across a magnetic field of a permanent magnet, the magnetic field due to the current in the conductor interacts with the magnetic field due to the permanent magnet. This interaction results in a force being produced on the conductor.

Magnetic field due to permanent magnet

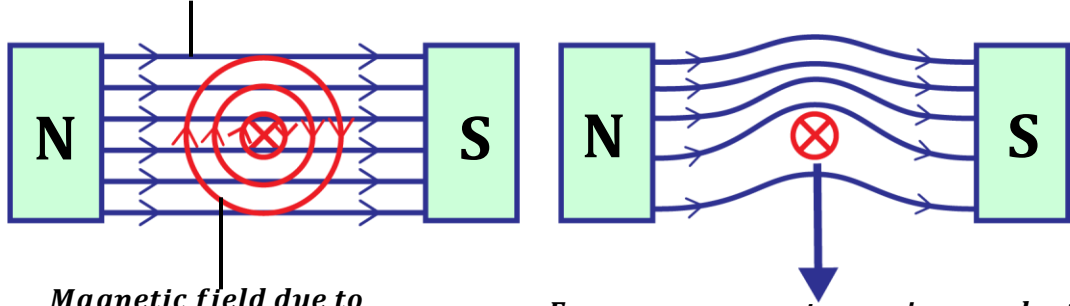

Magnetic field due to current carrying conductor

Force on a current carrying conductor

(a) Individual magnetic fields

(b) Combined magnetic fields



DIRECTION OF FORCE:

The direction of force exerted on a conductor can be found by using Fleming's left hand rule.

Fleming's left hand rule;

It states that if the left hand is held with the thumb, first finger and second finger placed at right angles to each other, the thumb points in the direction of force, the first finger points in the direction of magnetic field and second finger points in the direction of current.

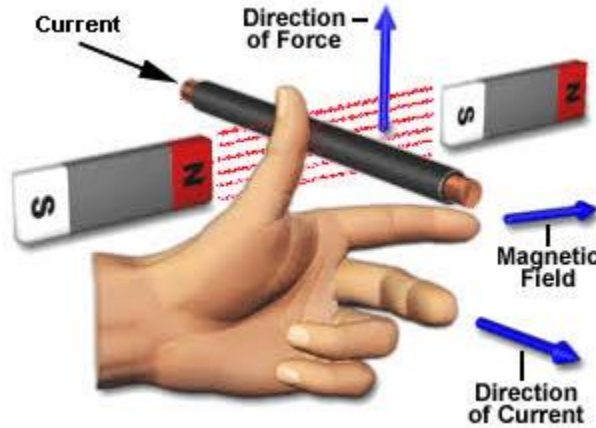
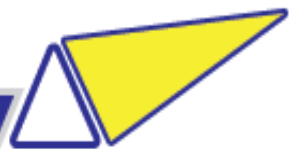
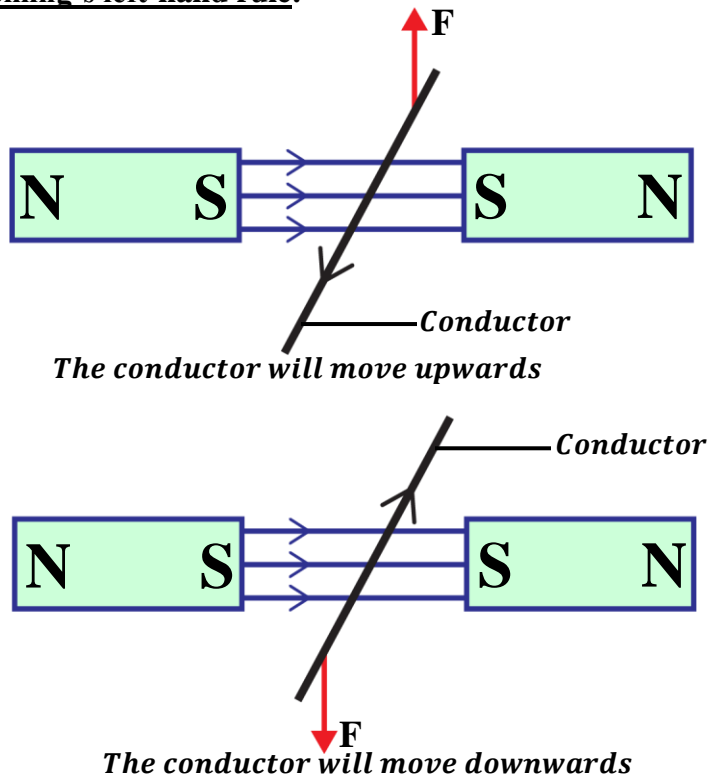
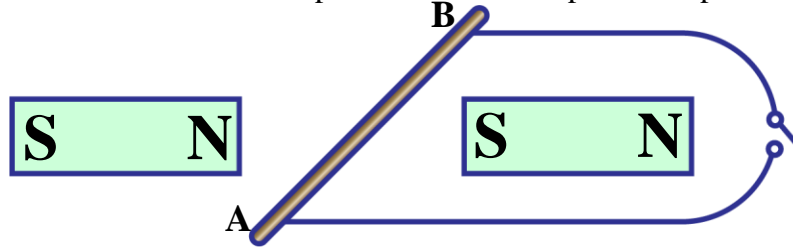

Illustration of Fleming's left-hand rule:



Example:

The diagram below shows a wire AB placed between the poles of a permanent magnet.



State what is observed when current flows in the wire using Fleming's left hand rule.

(i) In the direction AB.

The wire moves upwards

(ii) In the direction BA.

The wire moves downwards

Factors that affect magnitude of force on a current carrying conductor:

a) **Amount of current:**

Increasing the amount of current flowing in the conductor increases the magnitude of force created.

b) **Strength of magnetic field:**

Increasing the strength of magnetic field increases the magnitude of force created. This can be done by using a stronger magnet.

c) **Length of a conductor:**

Increasing the length of a conductor increases the magnitude of force created.

d) **Cross sectional area of a conductor:**

The larger the cross-sectional area of a conductor, the larger the force created.

NOTE:

When the magnetic field and current are parallel to each other, no force is exerted on the conductor.

Force between two parallel conductors carrying current in opposite directions

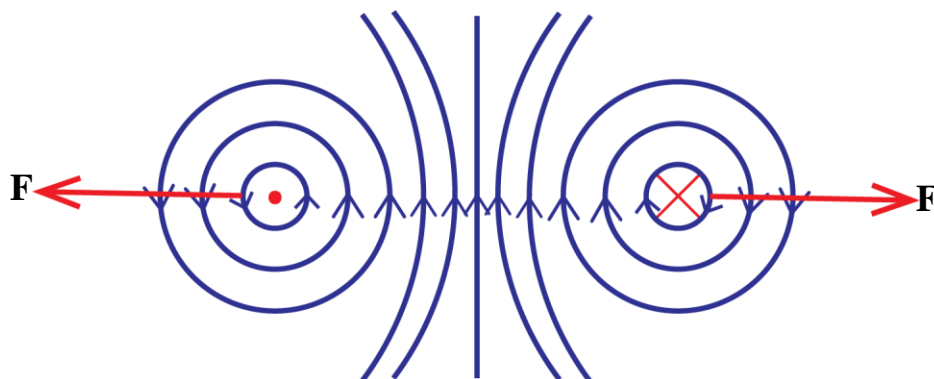

The conductor repel each other



Force between two parallel conductors carrying current in the same direction

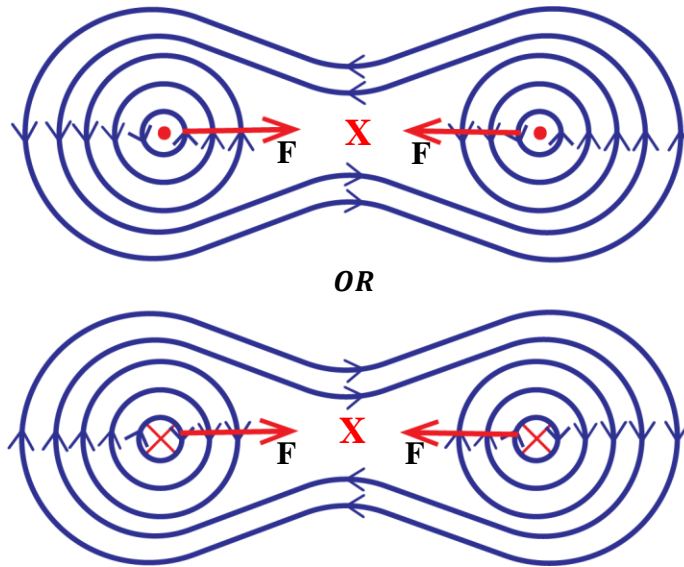

The conductor attract each other

APPLICATIONS OF MOTOR EFFECT

Force on a current carrying conductor can be applied in the following;

- Moving coil loud speaker
- D.C motor
- Moving coil galvanometer

MOVING COIL LOUD SPEAKER:

It consists of a light coil of wire known as a voice coil placed in a magnetic field provided by the permanent magnet.

Loud speakers can be used in; radios, Bluetooth speakers etc.

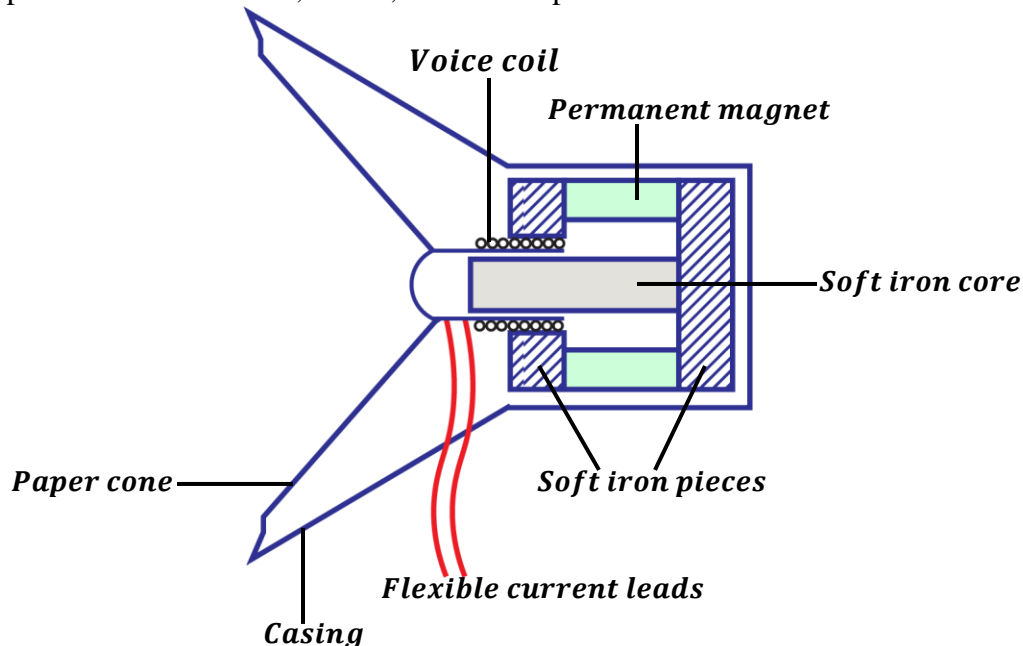

Mode of operation of a moving coil galvanometer:

- When varying current flows into the voice coil in a radial magnetic field of the permanent magnet, the voice coil experiences a varying force and vibrates at the same frequency as the current.
- This sets the paper cone to also vibrate at the same frequency as the current in voice coil.
- The vibration of the paper cone sets the air in contact with it to vibrate thus a loud sound is heard.

ELECTRIC MOTOR (D.C MOTOR)

The direct current motor converts electrical energy to kinetic energy.
They are used in; Printers, Fans, Water pumps etc.

Structure:

It consists of a rectangular coil which can rotate in a magnetic field provided by the permanent magnet. The ends of the coil are connected to two halves of a copper ring (split rings or commutators)

Two carbon brushes press against the commutators so that when the circuit is connected to a battery the coil rotates.

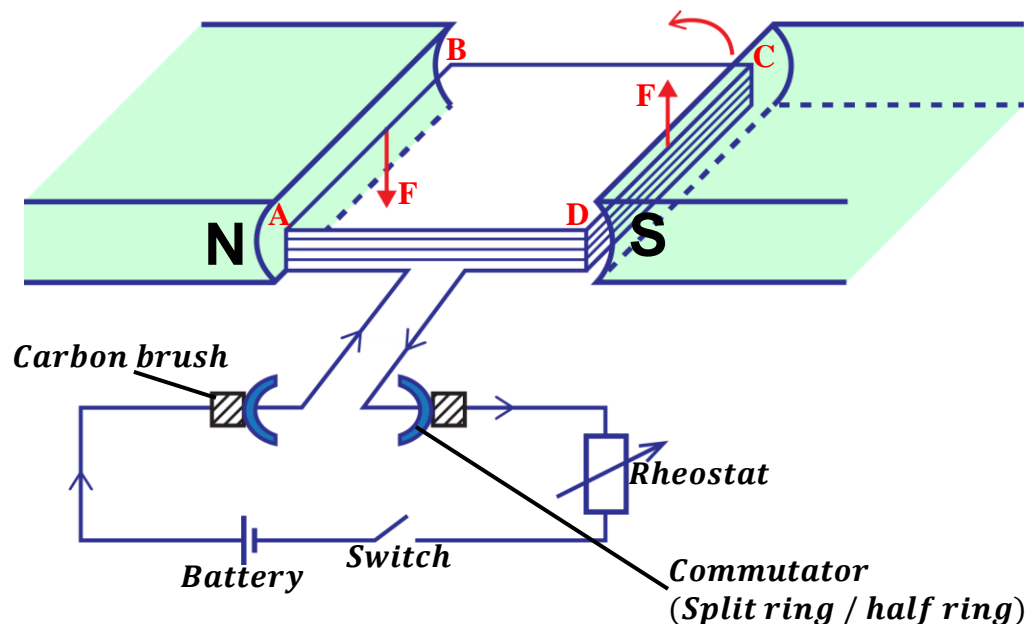
Mode of operation:

- When the switch is closed, current flows into the rectangular coil ABCD.
- Side CD experiences an upward force and side AB experiences a downward force according to Fleming's left hand rule.
- The two forces form a couple which causes the coil to rotate in the anticlockwise direction.
- When the coil rotates until it reaches the vertical position, the carbon brushes lose contact with the commutator and current is cut off.
- However, the coil continues to rotate and passes over the vertical position due to the momentum gained.
- The two commutators interchange contacts with the carbon brushes.



- This reverses the direction of current in the coil and the forces experienced by the sides of the coil.
- The coil continues to rotate as long as current is flowing.

Energy losses in an electric motor and how they are minimized.

ENERGY LOSS	HOW TO MINIMIZE IT
<ul style="list-style-type: none"> ▪ Energy loss due friction e.g. between carbon brushes and commutators. ▪ Energy loss due to heating effect in the coil due to resistance. ▪ Energy loss due to eddy currents. This is as a result of the changing magnetic flux in the coil. 	<ul style="list-style-type: none"> ▪ By lubricating i.e. oiling and greasing. ▪ By using thick copper wires of low resistance. ▪ By winding the coil on a laminated iron core.

Back emf of a motor;

When the coil cuts across the magnetic field of the permanent magnets, an emf is induced and acts in an opposite direction to the emf applied to rotate the motor.

The new emf induced is called **back emf**.

Let;

current through the armature = I_A

Initial emf applied to rotate the motor = E

Back emf induced = E_B

Resistance of the armature = R_A

Then;

$$\text{Current through the armature} = \frac{\text{Effective emf}}{\text{Resistance of the armature}}$$

$$I_A = \frac{E - E_B}{R_A}$$

$$\text{Efficiency of the motor} = \frac{\text{Power output}}{\text{Power input}}$$

$$\eta = \frac{I_A E_B}{I_A E} \times 100\%$$

$$\eta = \frac{E_B}{E} \times 100\%$$

The efficiency or strength of an electric motor can be increased by;

- Increasing current flowing through the coils.
- Increasing the number of turns in the coil.
- Using a stronger magnet to increase the strength of magnetic field.
- Winding the coil on a soft-magnetic material e.g. soft-iron.



Examples:

1. A motor whose armature resistance is 2Ω is operated on a 240V mains supply. Given the back emf in the motor is 220V.

Calculate;

- (i) the current through the armature.
 (ii) the efficiency of the motor.

$$\begin{aligned}
 & \text{(i)} \\
 R_A &= 2\Omega, \quad E = 240V, \quad E_B = 220V \\
 I_A &= \frac{E - E_B}{R_A} \\
 I_A &= \frac{240 - 220}{2} \\
 I_A &= \frac{20}{2} \\
 I_A &= 10A
 \end{aligned}$$

$$\begin{aligned}
 & \text{(ii)} \\
 \eta &= \frac{E_B}{E} \times 100\% \\
 \eta &= \frac{220}{240} \times 100\% \\
 \eta &= 91.7\%
 \end{aligned}$$

2. The current through the armature of an electric motor of resistance 6Ω is 2A. If the armature is connected to a 120V mains supply, calculate the efficiency of the motor.

$$\begin{aligned}
 R_A &= 6\Omega, \quad E = 120V, \\
 E_B &=?, \quad I_A = 2A, \quad \eta = ? \\
 I_A &= \frac{E - E_B}{R_A} \\
 2 &= \frac{120 - E_B}{6} \\
 E_B &= 120 - 12 \\
 E_B &= 108V
 \end{aligned}$$

$$\begin{aligned}
 \eta &= \frac{E_B}{E} \times 100\% \\
 \eta &= \frac{108}{120} \times 100\% \\
 \eta &= 90\%
 \end{aligned}$$

Exercise:

- A 240V vacuum cleaner motor takes a current of 0.6A. Find the efficiency of the motor if the useful mechanical power output is 72W. State how the rest of the energy is being wasted.
- An electric motor 90% efficient operates a water pump. If it raises 0.9kg of water through 20m every second, calculate;
 - Power output by the motor.
 - Back emf through the motor if the current through it is 5A.
 - Electric power supplied to the motor (power input).

MOVING COIL GALVANOMETER:

This is a device used to detect small currents and small potential differences (voltages)

Structure:

It consists of a rectangular coil wound on an aluminium former and placed over a cylindrical iron core. The coil rotates in the radial magnetic field provided by the poles of the permanent magnets. The radial magnetic field ensures that the coil is always perpendicular to magnetic flux. Current flows in and out of galvanometer through the hair springs. The hair springs also controls the rotation of the coil and the pointer.



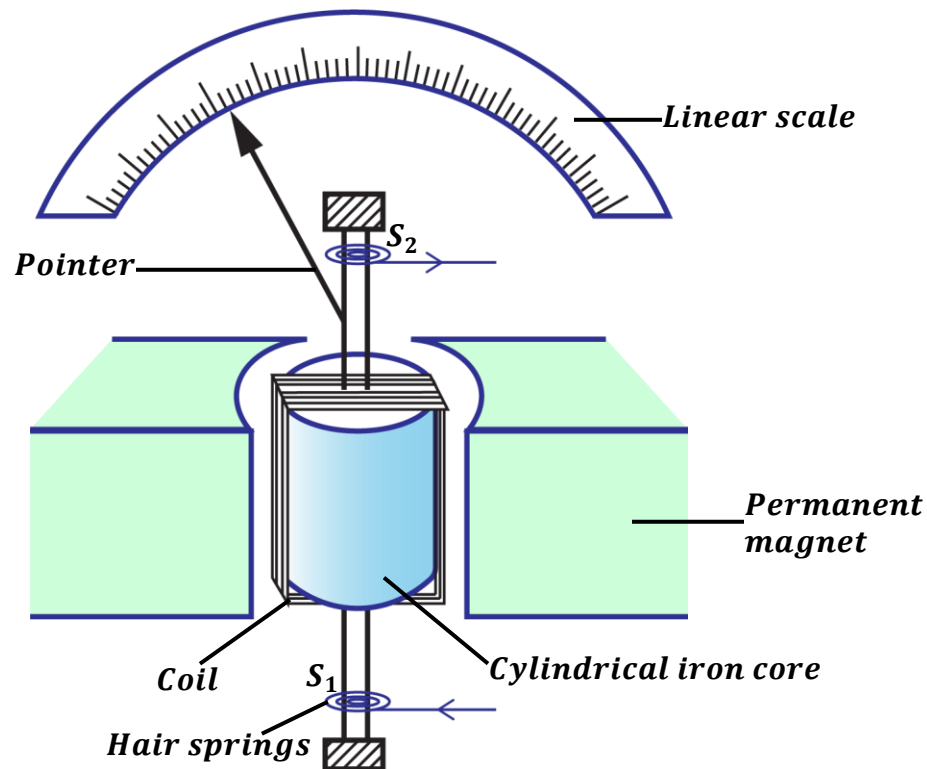

Mode of operation of a moving coil galvanometer:

- When current flows through the coil, the two vertical sides experience parallel opposite forces.
- The two forces form a couple which causes to rotate until it is stopped by the hair springs.
- As the coil rotates, the pointer deflects on the linear scale showing the amount of current flowing in the coil.
- When current stops flowing, the hair springs return the pointer to zero position on the scale.

SENSITIVITY OF A GALVANOMETER:

A galvanometer is said to be more sensitive if it can detect very small currents and very small voltages.

There are two types of sensitivity namely;

Current sensitivity: This is the deflection per unit current.

Voltage sensitivity: this is the deflection per unit voltage.

How to increase the sensitivity of a galvanometer.

- By using a strong magnet to provide a strong magnetic field.
- By increasing the number of turns on the coil.
- By using a coil of large cross sectional area.
- By using very weak hair springs.

Advantages of a moving coil galvanometer:

- It is used to measure both alternating and direct current.
- It has a linear scale.
- It is not affected by external magnetic fields.
- It is portable.



CONVERTING A GALVANOMETER INTO A VOLTMETER

Recall: A voltmeter has a high resistance so that no current can pass through it.

A galvanometer reads very small voltages in milli-voltages and can be converted into a voltmeter to read large voltages.

This can be done by connecting a **multiplier** in series with the galvanometer.

Definition:

A **multiplier** is a resistor of high resistance.

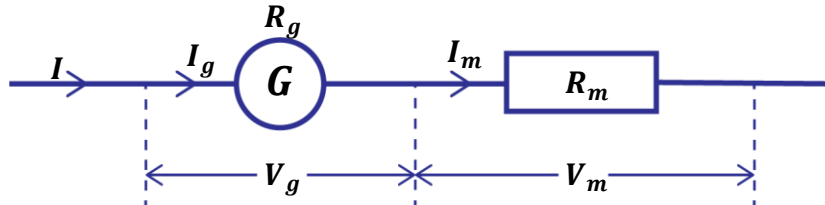

Total P.d = P.d across galvanometer + P.d across multiplier

$$V = V_g + V_m$$

But from Ohm's law $V_g = I_g R_g$, $V_m = I_m R_m$

$$V = I_g R_g + I_m R_m$$

Since the galvanometer and multiplier are in series, the current through galvanometer is equal to current through multiplier i.e. $I_g = I_m$

$$V = I_g R_g + I_g R_m$$

Examples:

1. A moving coil galvanometer of resistance 6Ω gives a full scale deflection of 15mA . How can it be converted to a voltmeter which can measure a maximum voltage of 5V ?

$$I_g = 15\text{mA} = \frac{15}{1000} = 0.015\text{A} \quad V = 5\text{V}$$

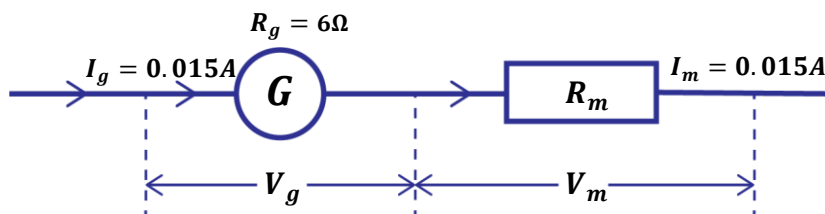

$$V = V_g + V_m$$

$$V = I_g R_g + I_m R_m$$

$$5 = 0.015 \times 6 + 0.015 \times R_m$$

$$5 = 0.09 + 0.015 R_m$$

$$\frac{5 - 0.09}{0.015} = R_m$$

$$R_m = 327.33\Omega$$

A multiplier of 327.33Ω should be connected in series with the galvanometer.



2. A moving coil galvanometer reads 0.05A at full scale deflection and has a resistance of 2Ω . Calculate the resistance that should be connected in series with the galvanometer so as to convert it to a voltmeter which reads 15V at full scale deflection.

$$I_g = 0.05A \quad V = 15V$$

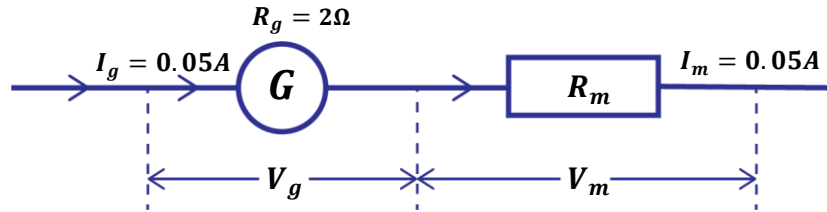

$$V = V_g + V_m$$

$$V = I_g R_g + I_m R_m$$

$$15 = 0.05 \times 2 + 0.05 \times R_m$$

$$15 = 0.1 + 0.05R_m$$

$$\frac{15 - 0.1}{0.05} = R_m$$

$$R_m = 298\Omega$$

A multiplier of 298Ω should be connected in series with the galvanometer.

CONVERTING A GALVANOMETER INTO AN AMMETER

Recall: An ammeter has a very low resistance so that a large current can pass through it. A galvanometer reads very small currents in milli-amperes and can be converted into an ammeter to read large currents.

This can be done by connecting a **shunt** in parallel with the galvanometer.

Definition:

A **shunt** is a resistor of low resistance.

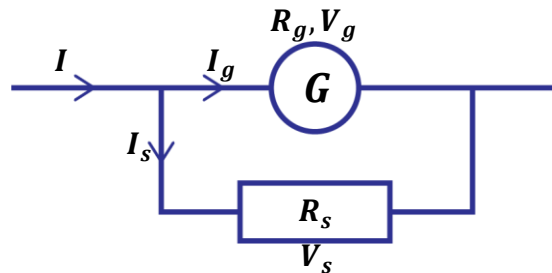

Total current = current through galvanometer + current through shunt.

$$I = I_g + I_s$$

$$I_s = I - I_g$$

Since the galvanometer and shunt are in parallel, the P.d across the galvanometer is equal to P.d across the shunt.

$$V_g = V_s$$

But from Ohm's law $V_g = I_g R_g$, $V_s = I_s R_s$

$$I_g R_g = I_s R_s$$

$$R_s = \frac{I_g R_g}{I_s}$$



Examples:

1. A galvanometer of resistance 20Ω gives a full scale deflection of 5mA . How can it be converted to an ammeter which can measure a maximum current of 2A ?

$$I_g = 5\text{mA} = \frac{5}{1000} = 0.005\text{A}$$

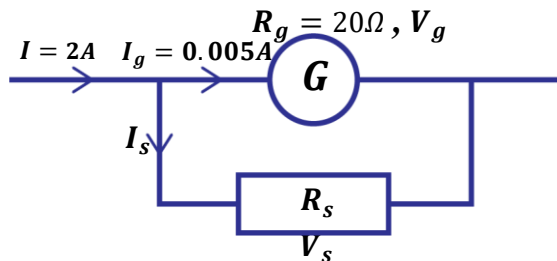

$$\begin{aligned} I &= I_g + I_s \\ I_s &= I - I_g \\ I_s &= 2 - 0.005 \\ I_s &= 1.995\text{A} \end{aligned}$$

$$\begin{aligned} V_g &= V_s \\ I_g R_g &= I_s R_s \\ 0.005 \times 20 &= 1.995 \times R_s \\ 0.1 &= 1.995 R_s \\ R_s &= \frac{0.1}{1.995} \\ R_s &= 0.05\Omega \end{aligned}$$

A shunt of resistance 0.05Ω should be connected in parallel with the galvanometer.

2. A moving coil galvanometer of resistance 4Ω gives a full scale deflection of 25mA . Calculate the value of the resistance required to convert it to an ammeter which reads 15A at f.s.d.

$$I_g = 25\text{mA} = \frac{25}{1000} = 0.025\text{A}$$

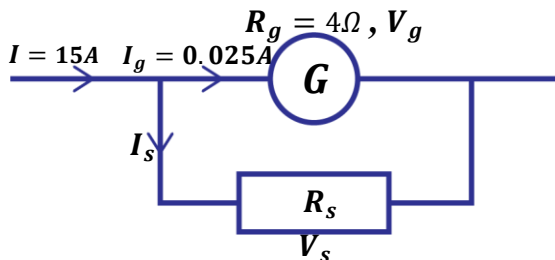

$$\begin{aligned} I &= I_g + I_s \\ I_s &= I - I_g \\ I_s &= 15 - 0.025 \\ I_s &= 14.975\text{A} \end{aligned}$$

$$\begin{aligned} V_g &= V_s \\ I_g R_g &= I_s R_s \\ 0.025 \times 4 &= 14.975 \times R_s \\ 0.1 &= 14.975 R_s \\ R_s &= \frac{0.1}{14.975} \\ R_s &= 0.006678\Omega \end{aligned}$$

A shunt of resistance 0.006678Ω should be connected in parallel with the galvanometer.

3. A moving coil galvanometer of internal resistance 4Ω gives a maximum deflection when a current of 2mA flows through it. A shunt of resistance 0.06Ω is used to convert the galvanometer into an ammeter.
- Find the current through the shunt.
 - The maximum current that can be measured by the set up.



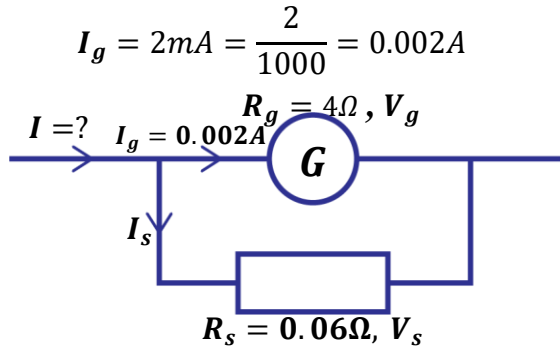

(i)

$$V_g = V_s$$

$$I_g R_g = I_s R_s$$

$$0.002 \times 4 = I_s \times 0.06$$

$$0.008 = 0.06 I_s$$

$$I_s = \frac{0.008}{0.06}$$

$$I_s = 0.133A$$

(ii)

$$I = I_g + I_s$$

$$I = 0.002 + 0.133$$

$$I = 0.135A$$

4. A moving coil galvanometer of resistance 5Ω and current sensitivity of 2 divisions per milliampere gives a full-scale deflection of 16 divisions.
- (i) Calculate current through the galvanometer.
- (ii) Calculate the voltage across the galvanometer if 1 division represents 2V.

(i)

Current sensitivity = 2div/mA
Full scale deflection = 16divisions

$$\begin{array}{l} 2div \rightarrow 1mA \\ 16div \rightarrow I_g \\ I_g = \frac{16}{2} = 8mA \end{array}$$

(ii)

Voltage sensitivity = 1div/2V
Full scale deflection = 16divisions

$$\begin{array}{l} 1div \rightarrow 2V \\ 16div \rightarrow V_g \\ V_g = 16 \times 2 = 32V \end{array}$$

EXERCISE:

- A moving coil galvanometer of resistance 4Ω gives a full scale deflection of 1.5mV. How can it be converted to voltmeter which can measure a maximum voltage of 2V?
Ans: [5329.3Ω]
- A moving coil galvanometer of resistance 10Ω gives a full scale deflection of 25mA. How can it be converted to an ammeter which can measure a maximum current of 2.5A?
Ans: [0.101Ω]
- A moving coil galvanometer of resistance 50Ω gives a full scale deflection of 5mV. How can it be converted to an ammeter which can measure a maximum current of 2A?
Ans: [0.0025Ω]
- Consider a full scale deflection when a current of 15mA flow through it. If the resistance of the galvanometer is 5Ω , find the magnitude of the resistance (multiplier) to be used for it to measure a maximum p. d of 15V
Ans: [995Ω]
- A moving coil galvanometer has resistance of 0.5Ω and full scale deflection of 2mA. How can it be modified to read current to voltage 10V
Ans: [4999 Ω]
- A moving coil galvanometer has resistance of 0.5Ω and full scale deflection of 2mA. How can it be adopted to read current 6A?
Ans: [1.67 × 10⁻⁴Ω]



7. Consider a moving coil galvanometer which has resistance of 5Ω and full scale deflection when a current of 15mA . A suppose a maximum current of 3A is to be measured using this galvanometer. What is the value of the shunt required.
Ans: [0.025 Ω]
8. A galvanometer of internal resistance of 20Ω and full scale deflection of 5mA . How can it be modified for use as;
(i) 1.0A ammeter
(ii) 100V voltmeter
Ans: (i). [1.05 Ω] (ii). [1980 Ω]
9. A milliammeter has a full scale reading of 0.01A and has resistance 20Ω . Show how a suitable resistor may be connected in order to use this instrument as a voltmeter reading up to 10V .
Ans: [980 Ω]

ELECTROMAGNETIC INDUCTION

When a conductor (e.g. wire) moves across a magnetic field such that it cuts the magnetic field lines (magnetic flux), an emf/current is induced in the conductor. Therefore, an emf is induced whenever magnetic flux changes and the induced emf causes current to flow.

Definition:

Electromagnetic induction is the process by which an emf is induced in the coil due to change in magnetic flux linking the coil.

Factors that determine the magnitude of induced emf/current:

- (i) **Number of turns;**
The magnitude of induced emf is increased by increasing the number of turns of the coil.
- (ii) **Strength of the magnet;**
The magnitude of induced emf can be increased by using a strong magnet to provide a stronger magnetic field.
- (iii) **Area of coil in magnetic field;**
The magnitude of induced emf is increased by placing a large area of coil into the magnetic field.
- (iv) **Rate at which magnetic flux changes;**
Increasing the speed of motion of a magnet in the coil increases the size of emf induced.



Direction of induced emf/current:

The direction of induced current can be found by Fleming's right hand rule.

It states that if the thumb, first and second fingers are placed at right angles to each other,

- thumb points in the direction of force (motion)
- the first finger points in the direction of magnetic field
- second finger points in the direction of induced current.

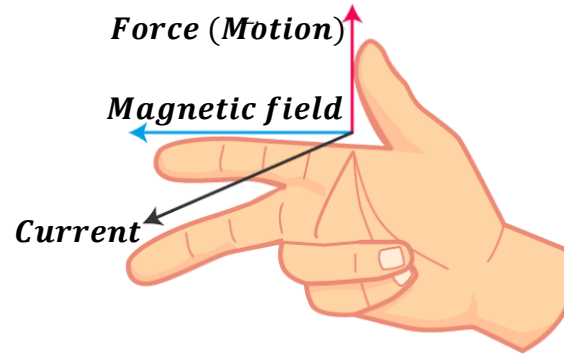

LAWS OF ELECTROMAGNETIC INDUCTION:

There are two laws of electromagnetic induction namely;

- Faraday's law
- Lenz's law

Faraday's law:

It states that the magnitude of induced emf in a coil is directly proportional to the rate of change of magnetic flux linking the coil.

Lenz's law:

It states that the induced current flows in a direction so as to oppose the change causing it.

Experiment to verify Lenz's law of electromagnetic induction:

Ends of a solenoid are connected to a galvanometer.

A magnet with its south pole facing towards the solenoid is moved into the coil and then pulled out.

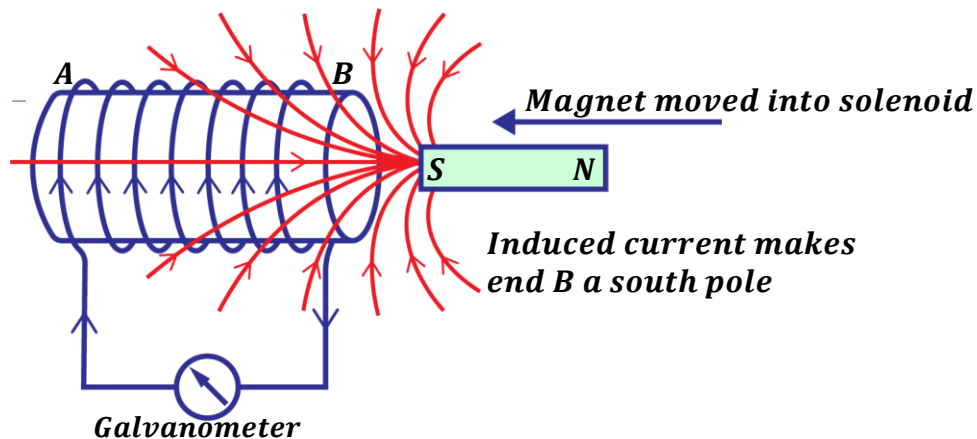

When a magnet is moved/plunged into the solenoid;

- **The galvanometer deflects to the left.** This is because current is induced in the solenoid and it flows in a clockwise direction to produce a South pole to oppose the approaching magnet. (**Fleming's right hand rule**)
- **The magnet is repelled by the solenoid.** This is because the induced current is flowing in the direction that makes end B of the solenoid to be a south pole.

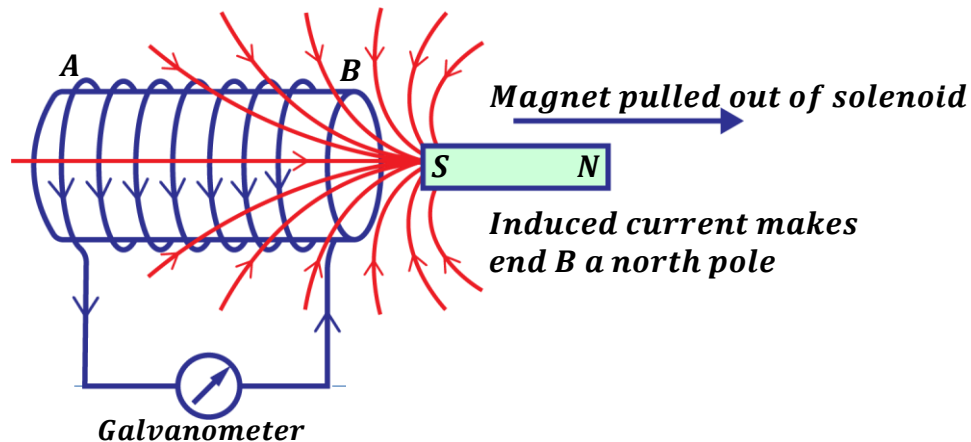

When a magnet is pulled out of the solenoid;

- **The galvanometer deflects to the right.** This is because current is induced in the solenoid and it flows in an anticlockwise direction to produce a North pole to oppose the leaving magnet. (**Fleming's right hand rule**)
- **The magnet is attracted by the solenoid.** This is because the induced current is flowing in the direction that makes end B of the solenoid to be a north pole.

Note: The speed of deflection of pointer on the galvanometer increases when the magnet is moved in and out at a faster rate.

Example:

1. The figure below shows a conductor connected to a galvanometer and placed in a magnetic field of two magnets.

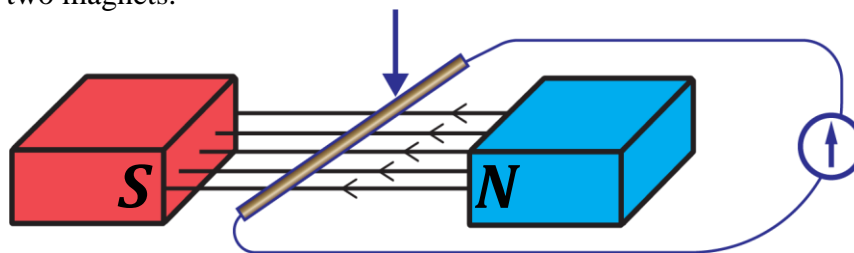

State what happens

- (a) When the conductor is moved down.

The galvanometer deflects to the left showing that current is induced in the conductor and it flows in clockwise direction.

- (b) When the conductor is moved up.

The galvanometer deflects to the right showing that current is induced in the conductor and it flows in anticlockwise direction.



- (c) when conductor is slowly moved up and then moved down faster
The galvanometer deflects to the right slowly and then to the left at a faster rate.
2. The figure below shows a magnet moved towards a cylindrical coil connected to a galvanometer.

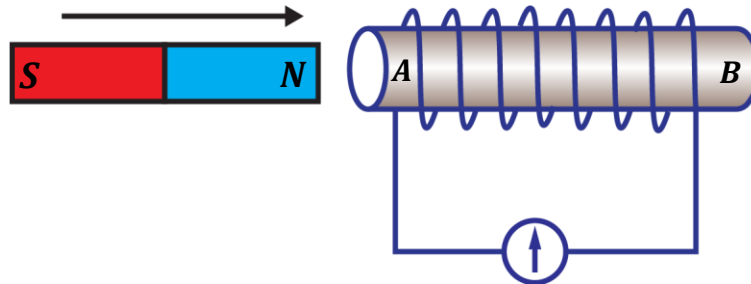

- (a) Explain what will be observed in the figure above.
The galvanometer deflects to the left because current is induced and it flows in a clockwise direction so that the end A is made a North pole to oppose the approaching magnet thus the magnet is repelled.
- (b) State how the magnitude of current induced in the figure above can be increased.
- *By increasing the number of turns of the coil.*
 - *By using a stronger magnet.*
 - *By increasing the speed at which the magnet is moving into the coil.*

APPLICATIONS OF ELECTROMAGNETIC INDUCTION

It is applied in;

- Generators
- Transformers

GENERATORS

A generator is a device that converts mechanical energy into electrical energy.

There are two types of generators namely;

- Direct current generator (dynamo)
- Alternating current generator (alternator)

D.C generator (Dynamo)

Structure:

It consists of the following;

- ❖ Permanent magnets which provide strong magnetic fields.
- ❖ An armature/ rectangular coil which rotates in the magnetic field.
- ❖ Carbon brushes which get current from split rings (commutators)



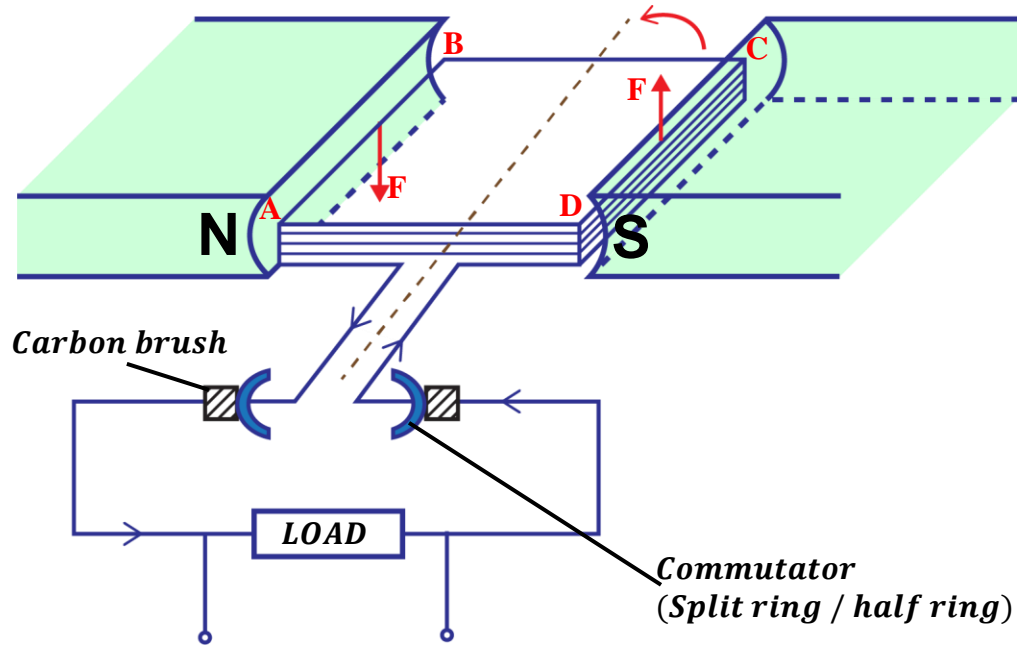

Mode of operation of a d.c generator

- When the rectangular coil ABCD rotates, the magnetic flux linking the coil changes and an emf is induced in the coil causing current to flow in the coil.
- When the coil passes over the vertical position, the split rings change contacts from one carbon brush to another. This reverses the direction of current in the coil.
- Therefore, the direction of current flowing through the load remains the same.

A graph of induced emf against time for a d.c generator.

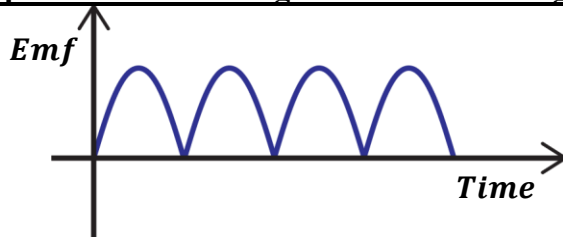

Note:

- The induced emf or current is maximum when the plane of the coil is horizontal. This is because cutting of the magnetic field lines is greatest at this point by the moving coil (*i. e.* 90°)
- The induced emf or current is minimum when the plane of the coil is vertical. This is because cutting of the magnetic field lines is minimum at this point by the moving coil (*i. e.* 0°)

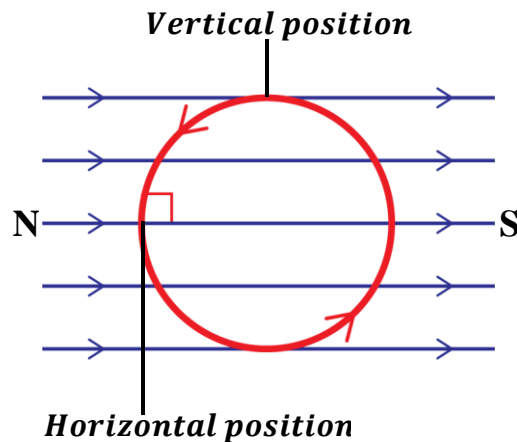

A.C generator (Alternator):

In A.C generators slip rings are used instead of split rings.

Note: A slip ring is a device that connects a stationary object (carbon brush) to a rotating object (rectangular coil)

Therefore, slip rings are always fixed.

Structure:

It consists of the following;

- ❖ Permanent magnets which provide strong magnetic fields.
- ❖ An armature / rectangular coil which rotates in the magnetic field.
- ❖ Carbon brushes which get current from the slip rings

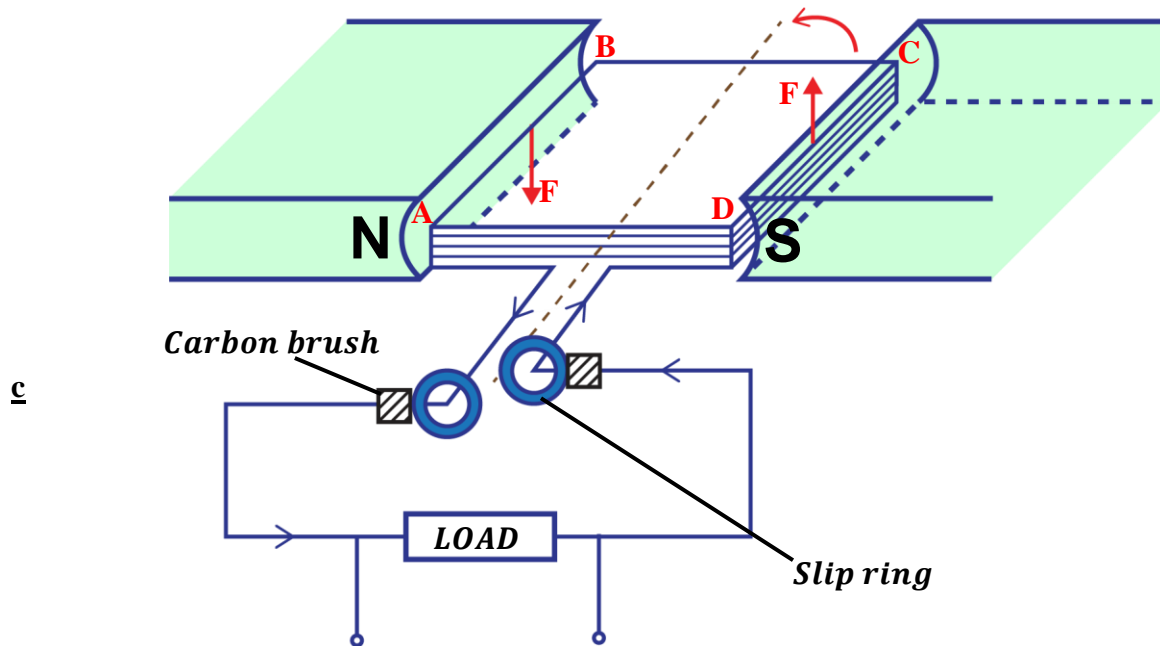

Mode of operation of an A.C generator

- When the rectangular coil ABCD rotates, the magnetic flux linking the coil changes and an emf is induced in the coil causing current to flow in the coil.
- When the coil passes over the vertical position, the slip rings change contacts from one carbon brush to another. This reverses the direction of current in the coil.
- Therefore, the direction of current flowing through the load also changes.

A graph of induced emf against time for an A.C generator.

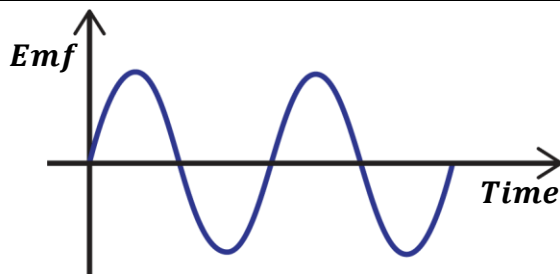

TYPES OF INDUCTION

There are two types namely;

- Self -induction
- Mutual induction

Self- induction:

This is the process by which an emf is induced in the coil due to changing current in the same coil.

The magnetic flux due to the current in the coil links that coil and if the current changes, the resulting flux change induces an emf in the coil itself.

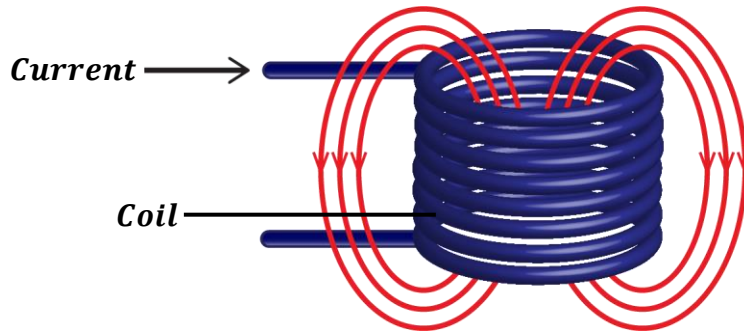

Mutual induction:

This is the process by which an emf is induced in the coil due to changing current in the nearby coil.

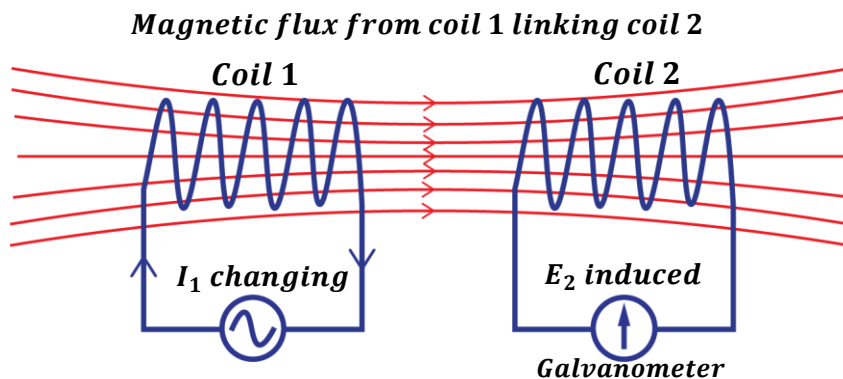

In mutual induction, emf is induced in coil 2 (secondary coil) due to change in current in coil 1 (primary coil).

This is applied in transformers



TRANSFORMERS

This is an electric device that is used to step up or step down voltage.

OR

This is an electric device that is used to increase or decrease alternating voltage.

Transformers are normally used in electrical appliances e.g. radio receivers, TV sets, battery chargers etc. where the input voltage has to be changed.

Structure of a transformer:

It consists of a laminated soft iron ring around which primary and secondary coils are wound. The soft iron ring concentrates the magnetic fields produced.

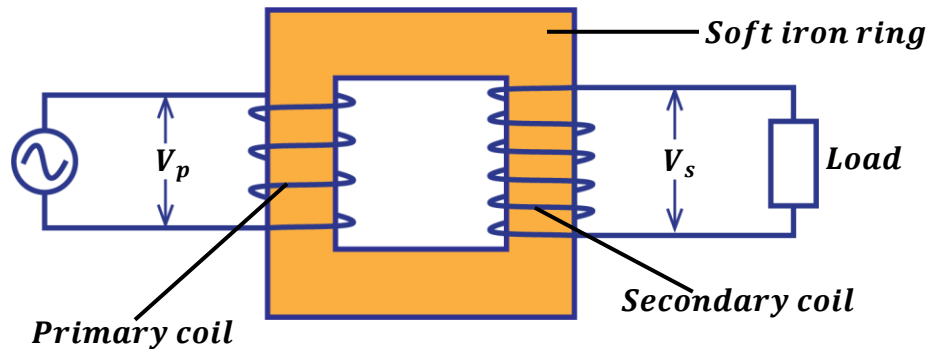

Mode of operation of a transformer:

- When alternating voltage V_p is applied to the primary coil, alternating current flows through the primary coil.
- The alternating current creates a changing magnetic flux in the primary coil which links up with the secondary coil.
- An emf V_s is induced in the secondary coil due to the changing magnetic flux.
- The induced emf depends on the number of turns in the secondary coil.

TYPES OF TRANSFORMERS:

There are two types namely;

(i) Step up transformer;

This is the type of transformer whose number of turns in the secondary coil is greater than the number of turns in the primary coil.

They are usually put at power and transmission stations.

(ii) Step down transformer;

This is the type of transformer whose number of turns in the secondary coil is less than the number of turns in the primary coil.

They are usually put near consumer places and in electrical appliances.



ENERGY/POWER LOSSES IN A TRANSFORMER

ENERGY LOSS	HOW IT IS MINIMIZED
(i) <u>Energy loss due to heating effect</u> (I^2R); <i>This is because of the resistance of the coils.</i>	By using low resistance thick copper wires.
(ii) <u>Energy loss due to eddy currents;</u> <i>Eddy currents are currents induced in the core due changing magnetic flux and they cause unnecessary heat.</i>	By using a laminated soft iron core.
(iii) <u>Energy loss due to hysteresis;</u> <i>This happens when magnetization of the core is reversed. So, if it is not easily magnetized and demagnetized, some power is wasted in overcoming internal friction.</i>	By using a soft iron core which can be easily magnetized and demagnetized.
(iv) <u>Energy loss due to flux leakage;</u> <i>This occurs when some magnetic flux fails to link up to the secondary coil.</i>	By using an E-shaped iron core so that all the flux in the primary coil links up to the secondary coil.

Uses of eddy currents:

- They are used in electromagnetic brakes.
- They are used to detect cracks in metals.

Transformer equations:

$$\frac{\text{Voltage in primary coil, } V_p}{\text{Voltage in secondary coil, } V_s} = \frac{\text{Number of turns in primary coil, } N_p}{\text{Number of turns in secondary coil, } N_s}$$

$$\boxed{\frac{V_p}{V_s} = \frac{N_p}{N_s}}$$

$$\text{Efficiency} = \frac{\text{Power output}}{\text{Power input}} \times 100\%$$

where Power output = power in secondary circuit = $I_s V_s$

Power input = power in primary circuit = $I_p V_p$

$$\boxed{\text{Efficiency} = \frac{I_s V_s}{I_p V_p} \times 100\%}$$

Definition:

An **ideal transformer** is a transformer where there are no energy losses.

Therefore, an ideal transformer is 100% efficient i.e. *power output = power input*

In real life situations, there is no transformer which is 100% efficient.



Examples:

1. A transformer is used to step down an alternating voltage from 240V to 12V. Calculate the number of turns on the secondary coil if the primary coil has 2000 turns.

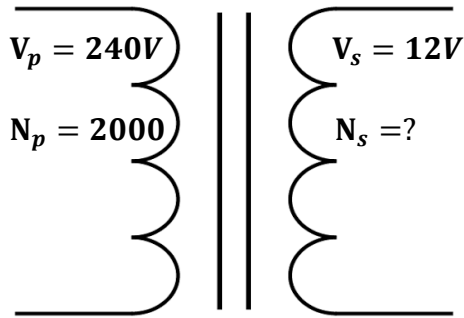

$$\frac{V_p}{V_s} = \frac{N_p}{N_s}$$

$$\frac{240}{12} = \frac{2000}{N_s}$$

$$N_s = \frac{2000 \times 12}{240}$$

$$N_s = 100 \text{ turns.}$$

2. A transformer whose efficiency is 80% has an output power of 12W. Calculate the input current if the input voltage is 240V.

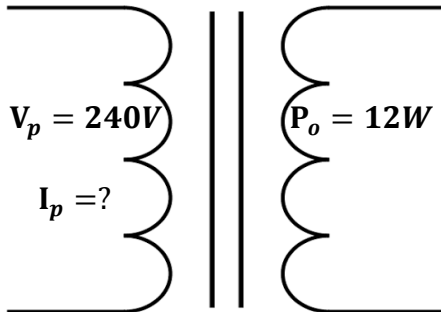

$$\text{Efficiency} = 80\%$$

$$\text{Efficiency} = \frac{\text{Power output}}{\text{Power input}} \times 100\%$$

$$80\% = \frac{12}{P_i} \times 100\%$$

$$P_i = \frac{12 \times 100}{80}$$

$$P_i = 15W$$

$$\text{Power input, } P_i = I_p V_p$$

$$15 = I_p \times 240$$

$$I_p = \frac{15}{240}$$

$$I_p = 0.0625A$$

3. A transformer is converted to 240V a.c mains. If the primary coil has 1200 turns and a resistor of 3Ω is connected to secondary coil of 60 turns.

Calculate;

- (i) p.d across the secondary coil.
(ii) current through the 3Ω resistor.

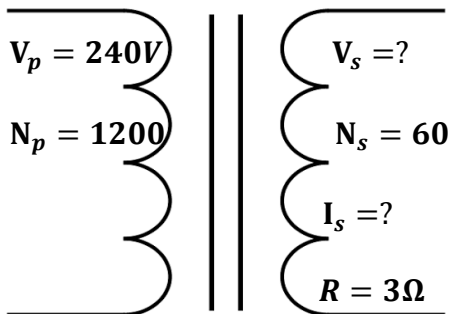

(i)

$$\frac{V_p}{V_s} = \frac{N_p}{N_s}$$

$$\frac{240}{V_s} = \frac{1200}{60}$$

$$V_s = \frac{240 \times 60}{1200}$$

$$V_s = 12V$$

(ii)

From ohm's law;

$$V_s = I_s R$$

$$12 = I_s \times 3$$

$$I_s = \frac{12}{3}$$

$$I_s = 4A$$



4. A transformer is designed to work on a 240V, 60W supply. It has 3000 turns in the primary and 200 turns in the secondary and it is 80% efficient. Calculate the current in primary and secondary coils.

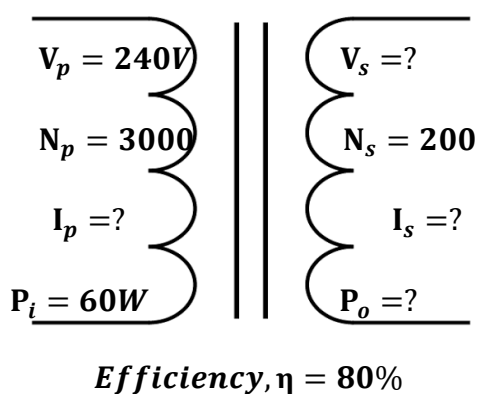

Current in primary coil

$$\text{power input} = I_p V_p$$

$$60 = I_p \times 240$$

$$I_p = \frac{60}{240}$$

$$I_p = 0.25A$$

$$\frac{V_p}{V_s} = \frac{N_p}{N_s}$$

$$\frac{240}{V_s} = \frac{3000}{200}$$

$$V_s = \frac{240 \times 200}{3000}$$

$$V_s = 16V$$

Current in second coil

$$\eta = \frac{P_o}{P_i} \times 100\%$$

$$\text{but } P_o = I_s V_s$$

$$80\% = \frac{I_s V_s}{P_i} \times 100\%$$

$$80 = \frac{I_s \times 16}{60} \times 100$$

$$I_s = \frac{80 \times 60}{16 \times 100}$$

$$I_s = 3A$$

5. A setup transformer is designed to operate from a 240V supply with delivery energy at 250V. If the transformer is 90% efficient, determine the current into the primary winding when the output terminals are connected to 250V, 100W lamp.

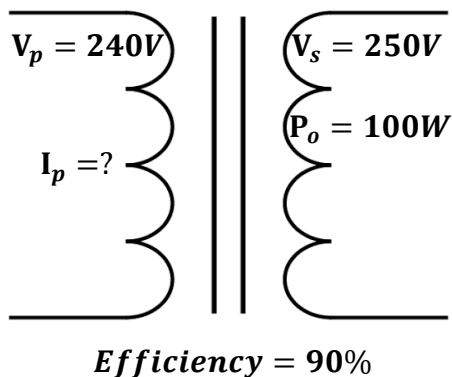

$$\text{Efficiency} = \frac{\text{Power output}}{\text{Power input}} \times 100\%$$

$$90\% = \frac{100}{P_i} \times 100\%$$

$$P_i = \frac{100 \times 100}{90}$$

$$P_i = 111.11W$$

$$\text{Power input, } P_i = I_p V_p$$

$$111.11 = I_p \times 240$$

$$I_p = \frac{111.11}{240}$$

$$I_p = 0.4629A$$

6. An electric power generator produces 24kW at 240V, the voltage is stepped up to 400V for transmission to a factory. The total resistance of the transmission wire is 0.5Ω.
- What is the ratio of number of turns in primary to number of turns in secondary is the transformer.
 - Find the power loss in transmission lines assuming both transformers are 100% efficient.



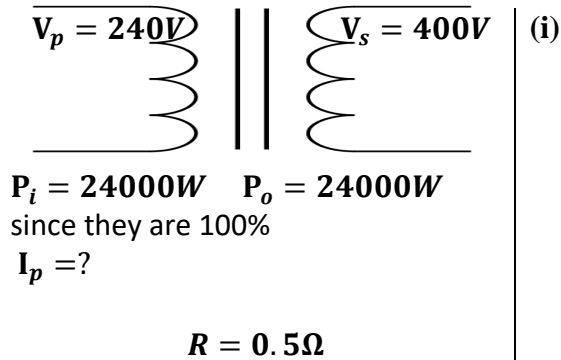

(i)

$$\frac{V_p}{V_s} = \frac{N_p}{N_s}$$

$$\frac{N_p}{N_s} = \frac{240}{400}$$

$$\frac{N_p}{N_s} = \frac{3}{5}$$

$$N_p : N_s = 3 : 5$$

(ii)

power output $P_o = I_s V_s$

$$24000 = I_s \times 400$$

$$I_s = \frac{24000}{400}$$

$$I_s = 60A$$

Power loss in wires

$$P = I_s^2 R$$

$$P = 60^2 \times 0.5$$

$$P = 1800W$$

7. A transformer is designed to operate at 240V main supply and deliver 9V. The current drawn from the main supply is 1A if the efficiency of the transformer is 90%. Calculate

- (i) maximum power output
 (ii) power lost

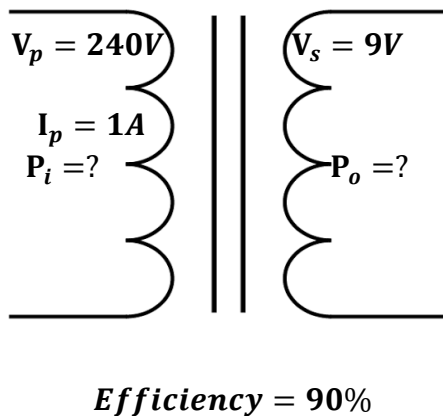

(i)

Power input, $P_i = I_p V_p$

$$P_i = 1 \times 240$$

$$P_i = 240W$$

$$\text{Efficiency} = \frac{\text{Power output}}{\text{Power input}} \times 100\%$$

$$90\% = \frac{P_o}{240} \times 100\%$$

$$P_o = \frac{90 \times 240}{100}$$

$$P_o = 216W$$

(ii)

powerlost = $P_i - P_o$

$$\text{powerlost} = 240 - 216$$

$$\text{powerlost} = 24W$$

EXERCISE:

- A transformer has 800 turns in its primary coil and 3200 turns in its secondary coil. If it is connected to an alternate voltage of 240V. What is the output voltage?
Ans: [960V]
- If one wishes to step down voltage from 240V to 10V, determine the number of turns in the secondary if the primary coil has 4800 turns.
Ans: [200 turns]
- A step up transformer is 80% efficient if the number of turns of the coil is 2400 turns and 500 turns. Given that the input voltage and the output current are 240V and 0.25A. Calculate the output voltage and input current.
Ans: [1152V, 0.015A]



4. Find the ratio of number of turns of the primary to the number of turns in the secondary, if the voltage of 12V is stepped up to 18V.
Ans: [2: 3]
5. A 3V, 6W bulb is connected to the secondary coil of a transformer whose input voltage is 12V. Given that the transformer is 90% efficient and the bulb works at full capacity. Calculate the current in the secondary coil and the current in the primary coil
Ans: [2A, 1.8A]
6. An electric power is generated at 11kV. Transformers are used to raise the voltage to 440V for transmission over long distances using cables. The output of transformers is 19800W and they are 90% efficient. Find the input current to the transformer and the output current to the cables.
Ans: [45A, 2A]
7. A transformer is designed to produce an output of 240V when connected to a 25V supply. If the transformer is 80% efficient, calculate the input current when the output is connected to a 240V, 75W lamp.
Ans: [0.3125A, 0.0375A]
8. An *a. c* transformer operates on a 240V mains. The voltage across the secondary which has 960 turns is 20V.
(i) find the number of turns in the primary coil.
(ii) if the efficiency of the transformer is 80% calculate the in the primary coil when a resistor of 40Ω is connected across the secondary.
Ans: [11520turns, 0.0521A]
9. A transformer whose secondary col has 60 turns and primary 1200 turns has its secondary connected to a 3Ω resistor if its primary is connected to a 240V *a. c* supply. Calculate the current flowing in the primary assuming that the transformer is 80% efficient.
Ans: [0.25A]
10. A transformer is designed to work on a 240V, 60W supply, it has 3000 turns in the primary and 200 turns in the secondary and its efficiency is 80%. Calculate the current in the secondary coil.
Ans: [3A]
11. An *a.c* transformer operates on 240V mains. It has 1200 turns in the primary and gives 18V across the secondary.
(i) find the number of turns in the secondary
(ii) if the efficiency of the transformer is 90% calculate the current in the primary coil when a resistor of 50Ω is connected across the secondary
Ans: [90turns, 0.03A]



ALTERNATING AND DIRECT CURRENT

Direct Current (D.C) is the current which flows in one direction only.
All batteries produce direct current.

Alternating Current (A.C) is current which flows in opposite directions periodically.
This means that the direction of current flowing in a circuit is constantly being reversed back and forth.

The electric current supplied to our homes is alternating current. This comes from power plants that are operated by the electric company.
AC can be converted to DC by using rectifier

Advantages of A.C over D.C

A.C is easy to generate.

A.C is easy to transmit to around the country with minimal power loss.

Alternating current can easily be stepped up and down for home consumption.

Disadvantages of A.C over D.C

A.C cannot be used to charge a battery.

A.C cannot be used in electroplating.

A.C cannot be used in electrolysis.

EXAMINATION QUESTIONS

- Define the term neutral point as applied to magnetism.
 - Briefly explain how a rod of steel can be magnetized using the single touch stroking method.
 - Briefly explain how the soft iron core causes power loss in a transformer.
 - What is a magnetic field.
 - Draw a diagram of the magnetic field pattern when a bar magnet is placed in the earth's magnetic field with its south pole facing the geographical north.
 - List four features of magnetic flux.
- Define the following terms as applied to magnetism.
 - Ferromagnetic material.
 - Neutral point.
 - The figure below shows an electromagnet made by a pupil in the laboratory. The electromagnet is to pick up and release a metal object.

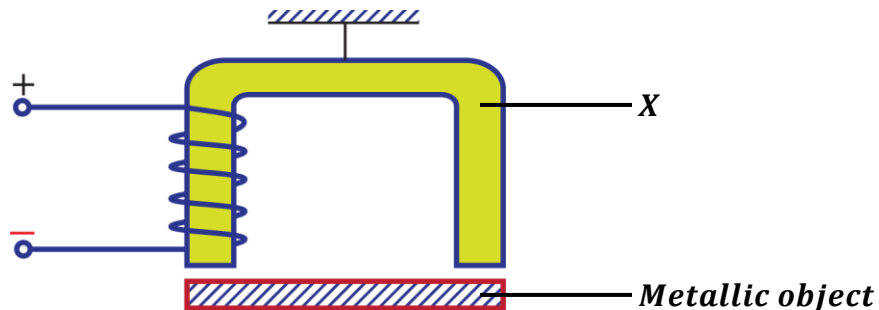

- i) Name a suitable material for X and explain why it is made from this material.
 - ii) Name two metals which a magnet will not attract.
 - iii) State two changes which a student could make so that a heavier metal object could be lifted by the electromagnet.
- c) A galvanometer of resistance 5Ω gives a full scale deflection for a current of 15mA. How may it be converted into?
- i) An ammeter reading up to 3A.
 - ii) A voltmeter reading up to 6V.

Ans: i) [$2.51 \times 10\Omega$] ii) [395Ω]

3. a) i) What is a magnetic field.
ii) State the law of magnetism.
- b) i) Explain with the aid of diagrams, how a steel bar can be magnetized by the single touch method.
ii) Sketch the magnetic field pattern around two bar magnets whose north poles face each other.
- c) With the aid of a labeled diagram, describe how a simple a.c generator works.
4. a) Describe briefly the structure and action of an a.c transformer.
- b) i) State any three causes of energy losses in a transformer.
ii) How are these losses reduced in a practical transformer?
- c) Explain why it is an advantage to transmit electrical power at high voltage.
- d) An electric power is generated at 11kV. Transformers are used to raise the voltage to 440kV for transmission over large distances using cables. The output of transformers is 19.8MW and they are 90% efficient. Find;
- i) The input current to the transformer.
 - ii) The output current to the cables.

Ans: i) [$2kA$] ii) [$45A$]

5. a) Explain how a piece of iron can be magnetized by the single touch method. Illustrate your answer with a diagram.
- b) How can you determine the polarity of a magnet?
- c) Explain why a magnet loses its magnetism when placed in a coil of a wire carrying an alternating current.
- d) Describe the motion of a beam of electrons directed midway between the north and south poles of a permanent magnet.
6. a) Describe with the aid of a labeled diagram, the structure and principle of operation of an a.c generator.
- b) An electric power generator produces 24kW at 240V a.c. The voltage is stepped up to 4000V for transmission to a factory, where it is then stepped down to 240V. The total resistance of the transmission wires is 0.5Ω .
- i) What is the ratio of the number of turns in the primary to the number of turns in the secondary of the step down transformer?
 - ii) Find the power lost in the transmission lines assuming both transformers are 100% efficient.

Ans: i) [$50: 3$] ii) [$18W$]

- c) i) What power would have been lost if the same electric power had been transmitted directly to the factory through the same transmission wires without use of transformers.



ii) Comment on differences between the power losses in (b) (ii) and (c) (i) above.

Ans: i) [15kW]

7. a) i) Draw a labeled diagram to show essential parts of a d.c motor.
ii) Describe briefly how a d.c motor works.
- b) State three ways of increasing the torque of the motor.
- c) i) What factors make the efficiency of a motor less than 100%?
ii) How is each factor in (c) (i) above minimized?
- d) An electric motor of efficiency 90% operates a water pump. The pump raises 0.9kg of water through 10m every second.
i) What is meant by the term efficiency?
ii) State the energy changes which take place.
iii) Find the electrical power supplied to the motor.

Ans: iii) [100W]

8. a) i) What is a magnetic field?
ii) Draw a diagram of the magnetic field pattern between the north poles of two bar magnets placed near each other.
- b) Describe how you can plot the magnetic field around a wire carrying a current perpendicular to the plane of the paper.
- c) Draw a diagram to show what happens when two straight conductors placed vertically near each other carry a current in
i) The same direction.
ii) The opposite direction.
- d) Describe briefly two methods of magnetizing an iron rod.
- e) A transformer is designed to produce an output of 220V when connected to a 25V supply. If the transformer is 80% efficient, calculate the input current when the output is connected to a 220V, 75W lamp.

Ans: [3.75A]

9. a) State three factors on which the magnitude of the force exerted on a wire carrying a current in a magnetic field depends.
- b) With the aid of a labeled diagram, describe the action of a moving coil galvanometer
- c) A moving coil galvanometer has a coil of resistance 4Ω and gives a full scale deflection when a current of 25mA passes through it. Calculate the value of the resistance required to convert it to an ammeter which reads 15A at full scale deflection.

Ans: [6.68 × 10⁻³Ω]

10. a) With the aid of a diagram explain, the use of keepers to store magnets.
- b) i) Describe using a labeled diagram how a telephone receiver works.
ii) State two ways by which the strength of an electromagnet can be increased.
- c) i) A part from electrical method, mention two other methods of demagnetization.
ii) Explain how the above methods mentioned lead to magnetization.
- d) Describe how you would demagnetize a bar magnet by the electrical method.



11. a) What is a transformer
 b) The diagram below shows a model of a transformer in which the primary coil, P is connected to d.c and the secondary coil, S is connected to the galvanometer, G.

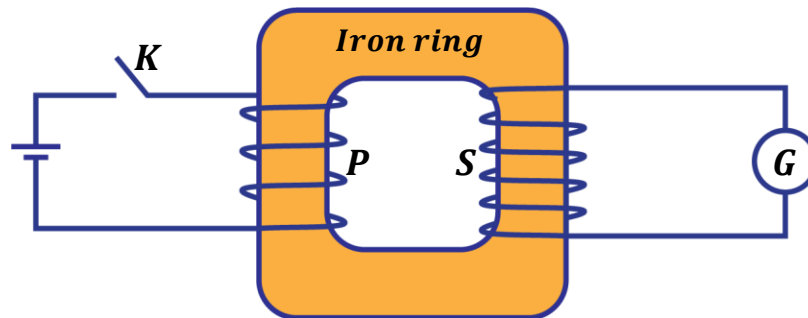

- What is observed just as the switch, K is closed.
 - What will be the effect of closing switch, K very fast in (i) above?
 - What is observed when the switch is left closed?
 - What is observed as the switch is opened.
 - What is observed if the d.c source is replaced by an a.c source of low frequency
- c) A transformer of efficiency 80% is connected to a 240V a.c supply to operate a heater of resistance 240Ω . If the current flowing in the primary circuit is 5A.
- Calculate the potential difference across the heater.
 - If the heater is cooled by oil of specific heat capacity $2,100Jkg^{-1}K^{-1}$ and the temperature of oil rises by 20° in 3 minutes, find the mass of oil used in cooling.

Ans: i) [48V] ii) [4.11kg]

12. a)
 - What is meant by a magnetic field.
 - Suggest any three characteristics of the magnetic field.
 b)
 - Describe in details how an iron bar can be magnetized by electrical method.
 - A galvanometer has resistance of 2Ω and gives a 50mA full scale deflection. Calculate the value of resistance that is used so that the meter reads current up to 2A.

Ans: ii) [5.13 × 10⁻²Ω]

- c) The diagram below is a transformer, study it and answer the questions that follow.

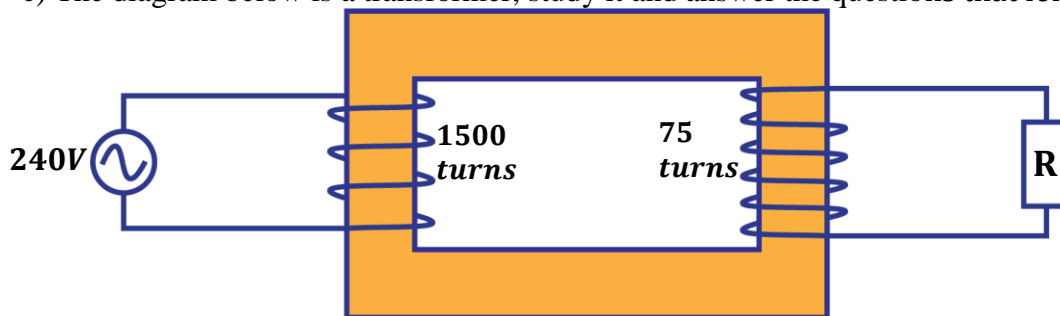

- Find the potential difference across R.
- If the current in the mains is 0.55A. What is the current in the secondary coil?
- With a reason name the type of the transformer.

Ans: i) [12V] ii) [11A]

13. a) State any two factors which determine the magnitude of a force exerted on a current carrying conductor.
 b) With the aid of a well labeled diagram, describe the structure and mode of action of a moving coil loud speaker.



- c) State the factors which determine the pitch and loudness of the sound produced by a moving coil loud speaker.
- d) A D.C motor has an armature resistance of 4Ω . If it draws a current of 10A when connected to a supply of 200V, calculate the
- Power wasted in the windings
 - Efficiency of the motor

Ans: i) [400W] ii) [80%]

14. a) The diagram below shows a coil connected to a centre-zero galvanometer, G.

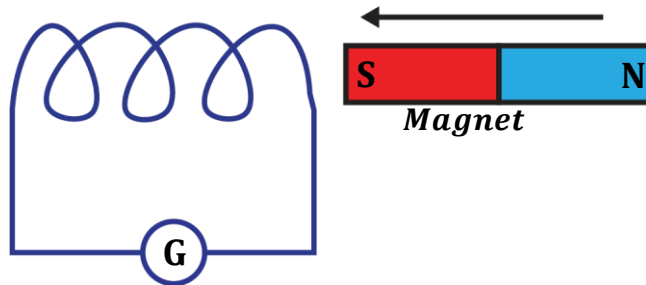

State and explain the deflection of the galvanometer needle when the magnet is

- Held stationary at one end of the coil
 - Moved slowly towards the coil
 - Left at rest inside the coil
 - Moved away from the coil
 - Moved quickly in and out of the coil about twice per second
- b) i) State four ways in which power is lost in a transformer
ii) How can the power loss be minimized in each case
- c) Distinguish between a d.c motor and a d.c generator
- d) An electric motor taking a current of 5A at 240V is connected by cable to a generator some distance away. If the p.d at the terminals of the generator is 250V, calculate
- The resistance of the cable
 - The power supplied by the generator and loss of power in the cable.
15. a) A bar magnet is placed with its axis along the magnetic meridian with its south pole pointing north.
- Sketch the magnetic flux pattern near the magnet in the earth's field.
 - With reference to the sketch, explain what is meant by a neutral point in a magnetic field
- b) i) Describe an experiment to determine the magnetic field pattern of a bar magnet using iron fillings.
ii) State one advantage and one disadvantage of the method in (b) (i).
- c) Describe how the earth's magnetic meridian may be determined.
- d) A galvanometer has a coil of resistance 8Ω and gives a full scale deflection when a current of 0.5mA is supplied. Calculate the resistance that can be used to convert it into an ammeter measuring up to 5A.

Ans: [8.0 × 10⁻⁴Ω]

16. a) i) What is a magnetic field
ii) State the law of magnetism
- b) i) Explain with the aid of a diagram how a steel bar can be magnetized by the single touch method.



- ii) Sketch the magnetic field pattern around two bar magnets whose north poles face each other.
17. a) With the aid of a labeled diagram describe how a simple ac generator works
 b) Explain with the aid of a diagram what happens when two vertical, parallel conductors are placed near one another and carry current in
 i) The same direction
 ii) The opposite direction
 c) i) Describe with the aid of a diagram, how a direct current generator works
 ii) State three ways of increasing the emf produced by the generator
18. a) What is meant by magnetic saturation
 b) Explain why freely suspended bar magnet swings until it points North South.
 c) With the aid of a diagram explain the use of magnetic keepers.
19. a) State any two factors which determine the magnitude of the emf induced in a coil rotating in magnetic field.
 b) i) Draw a diagram to show the construction of a step-down transformer
 ii) A transformer is used to step-up an alternating voltage from 20V to 240V. Calculate the number of turns in the primary coil if the secondary coil has 1200 turns.

Ans: [100 turns]

20. The figure shows a circuit

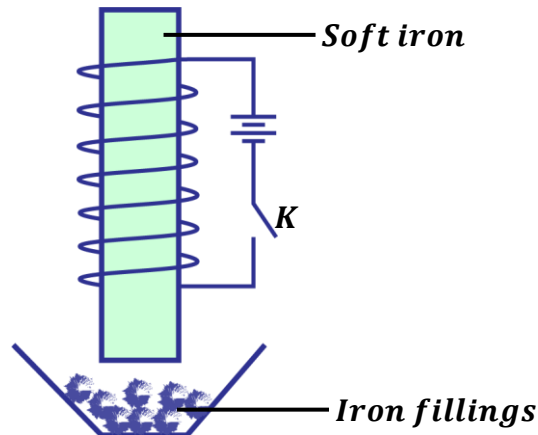

- a) Describe what is observed when the key, K, is closed
 (i) Closed
 (ii) Closed and then again opened
 b) State two ways by which the effect of what was observed in (a) (i) above can be increased.



Experiment 18

A small mass is attached to a length of thread as shown in Figure 18. This is referred to as the plumbline.

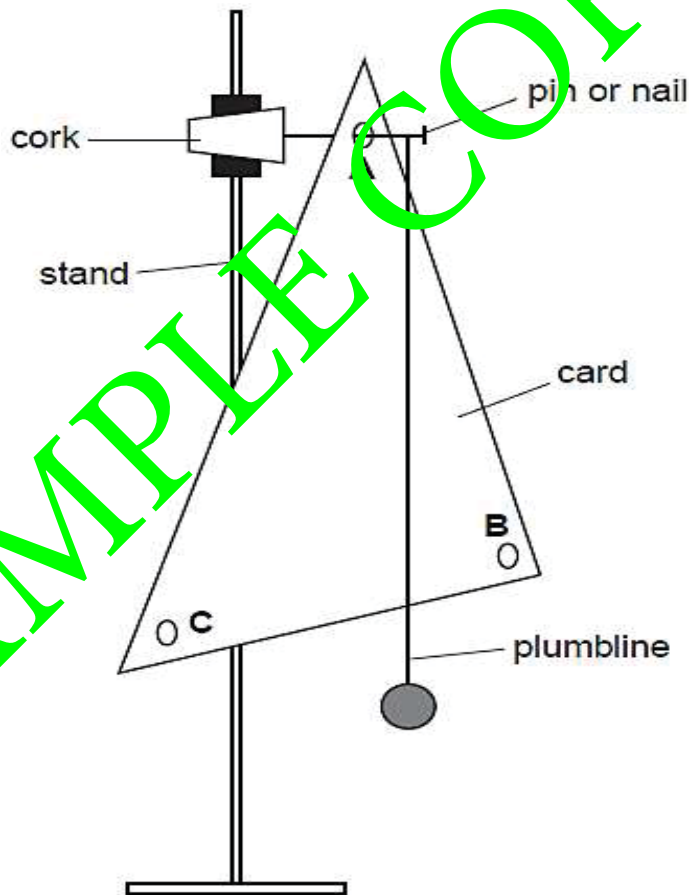

Fig. 18

- (a) Suggest a suitable title for this experiment.

.....
.....

- (b) Carry out the following instructions referring to Figure 18.

- (c) Measure and record the lengths of the three sides of the triangular sheet of card.

length 1 =

length 2 =

length 3 =

(01 mark)

- (d) (i) Hang the card on the nail through hole A.
(ii) Hang the plumbline from the nail so that it is close to the card but not touching it.
(iii) When the card and plumbline are still, make a small mark at the edge of the card where the plumbline crosses the edge.
(iv) Remove the card and draw a line from the mark to hole A.

Experiment 12

Imagine you are conducting an experiment to investigate the period of a pendulum. The apparatus is set up as described in the instructions, and you refer to Figure 12.1 and Figure 12.2. Follow the given steps to perform the experiment.

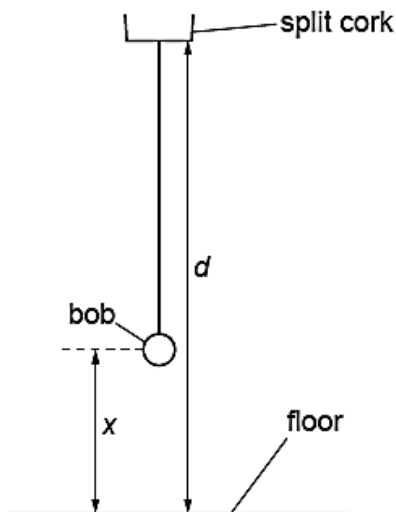

Fig. 12.1

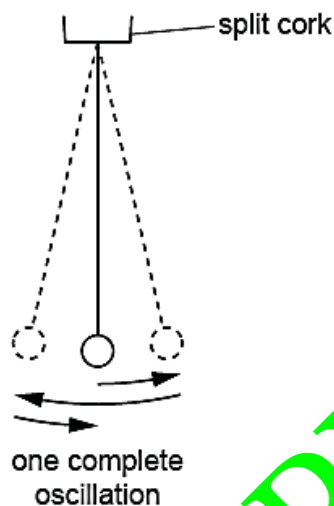

Fig. 12.2

- (a) Start by measuring the distance d between the bottom of the split cork and the floor.

$$d = \dots\dots\dots\text{cm} \quad (01 \text{ mark})$$

This distance d must remain constant throughout the experiment.

- (b) • Adjust the length of the pendulum until the distance x , measured from the centre of the bob to the floor, is 50.0 cm.
 • Displace the bob slightly and release it so that it swings. Figure 12.2 shows one complete oscillation of the pendulum.
 • Measure, and record in Table 12, the time t for 10 complete oscillations.
 • Calculate, and record in Table 12, the period T of the pendulum. The period is the time for one complete oscillation.
 • Calculate, and record in Table 12, T^2 . (02 marks)

Table 12

$x(\text{cm})$	$t(\text{s})$	$T(\text{s})$	$T^2(\text{s}^2)$
50.0			
45.0			
40.0			
35.0			
30.0			

- (c) From the experiment described above, identify:
- (i) The independent variable
 - (ii) The dependent variable
 - (iii) The constant variable
- (d) Repeat the procedure in (b) using $x = 45.0$ cm, 40.0 cm, 35.0 cm and 30.0 cm. (03 marks)
- (e) Plot a graph of T^2 (along the vertical axis) against x (along the horizontal axis). You do not need to start your axes at the origin (0,0). (04 marks)



- (f) Explain why timing 10 oscillations gives a more accurate result for the period T than timing one oscillation. (01 mark)

- (i) Measure and record in Table 25 the angle of incidence i between the line AN and the normal. Measure, and record in the table, the angle of reflection r between the normal and the line passing through P₂ and P₃.

Table 25

<i>edge</i>	$i(^{\circ})$	$r(^{\circ})$
A		
B		

(03 marks)

- (j) Repeat the steps (e) – (i) but using edge **B** of the card instead of edge **A**.
- (k) In spite of carrying out this experiment with care, it is possible that the values of the angle of reflection r will not be exactly the same as the values obtained from theory. Suggest **two** possible causes of this inaccuracy.

1.

 2.

(02 marks)

Insert your ray-trace sheet opposite this page.

(05 marks)

Experiment 26

Concave mirrors curve inward and are thicker at the center than at the edges, causing light rays parallel to the optical axis to converge. These mirrors are employed in applications such as reflecting telescopes for gathering and focusing light in astronomy, and in cosmetic mirrors where their ability to produce enlarged and upright images is utilized for personal grooming. However, it is necessary to determine the focal length, f of a concave mirror before its use.

- (a) A concave mirror is placed in a holder and used to focus light from a window onto a screen. The screen is adjusted until a sharp image is formed on it.
- (i) Measure and record the distance d , between the screen and mirror.

$d = \dots\dots\dots$ (01 mark)

- (ii) Explain the meaning of distance . (01 mark)

.....

- (b) Arrange the apparatus as shown in figure 38. Adjust the distance, u , of the torch bulb from the mirror to 15cm. Close switch K . Adjust the position of the white screen, S_2 until a sharply focused image of the wire gauze appears on it. Open switch K .

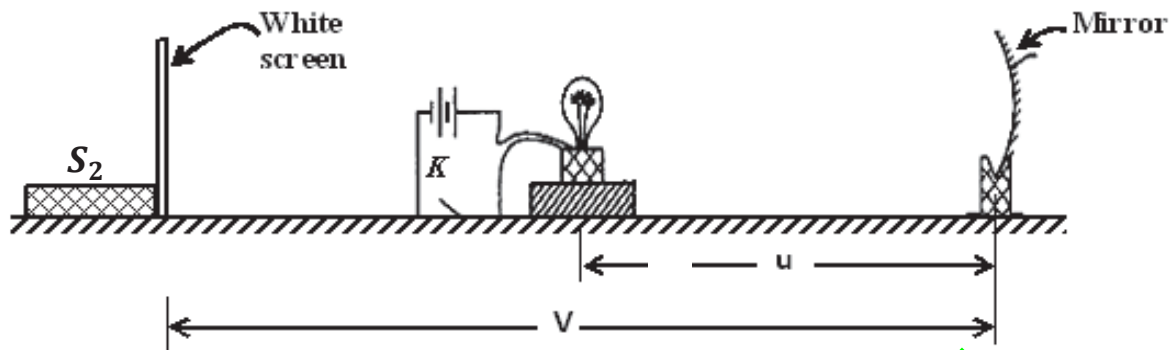

Fig. 38

- (c) Measure and record the distance, v of the screen S_2 from the mirror.

$v = \dots\dots\dots$ (01 mark)

- (d) Calculate the values of $y = V - d$ and $x = u - d$.

$y = \dots\dots\dots$ (01 mark)

$x = \dots\dots\dots$ (01 mark)

- (e) Repeat procedures (f) to (h) for values of $u = 35.0, 40.0, 45.0, 50.0$ and 55.0cm .

- (f) Tabulate your results including values of $\frac{1}{x}$.

Table 38

(06 marks)

- (g) From the experiment described above, identify:
- (i) The independent variable
 - (ii) The dependent variable
 - (iii) The constant variable

(h) Plot a graph of y against $\frac{1}{x}$. (06 marks)

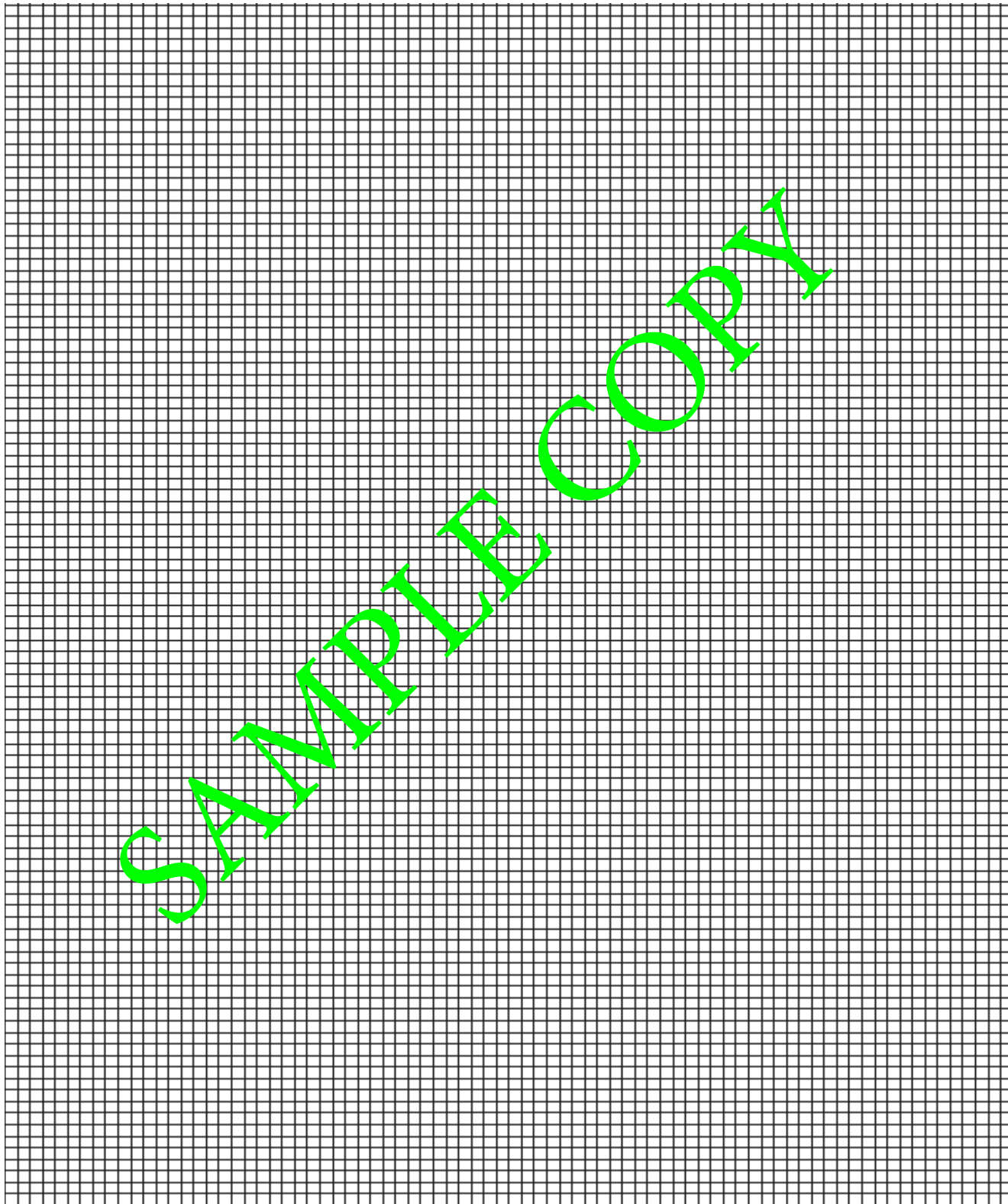

- (i) Determine the slope, S of the line of best fit. Show your working and indicate on the graph the values you use to calculate the gradient G .

$$S = \dots\dots\dots (02 \text{ marks})$$

- (j) Calculate the value of f_1 from $f_1 = \sqrt{S}$.

$$f_1 = \dots\dots\dots (02 \text{ marks})$$

- (k) Determine the value of the constant, f of the concave mirror using $f = \frac{1}{2}(f_1 + d)$

$$f = \dots\dots\dots (02 \text{ marks})$$

Experiment 27

This experimental investigation has two parts, (I) and (II).

PART I

A concave mirror is mounted in a mirror holder and a pin in cork is placed such that its pointed end lies along the axis of the mirror. The pin is moved towards and away from the mirror until it coincides with its image by no-parallax.

- (a) Suggest a suitable title for this experiment. (01 mark)

.....

- (b) State **one** suitable hypothesis that could be investigated. (01 mark)

.....

- (c) With the apparatus provided, set up this experiment. Measure and record the distance, N between the pin and the mirror.

$$N = \dots\dots\dots (01 \text{ mark})$$

- (ii) Calculate, the quantity, B from: $B = L \frac{S}{W_c N}$

(d) From the experiment you have just carried out, state; (04 marks)

(i) The aim of the experiment

T (ii) The independent variable

(ii) The dependent variable

(iii) The constant variable

(e) Plot a graph of $\frac{y}{x}$ against y . (06 marks)

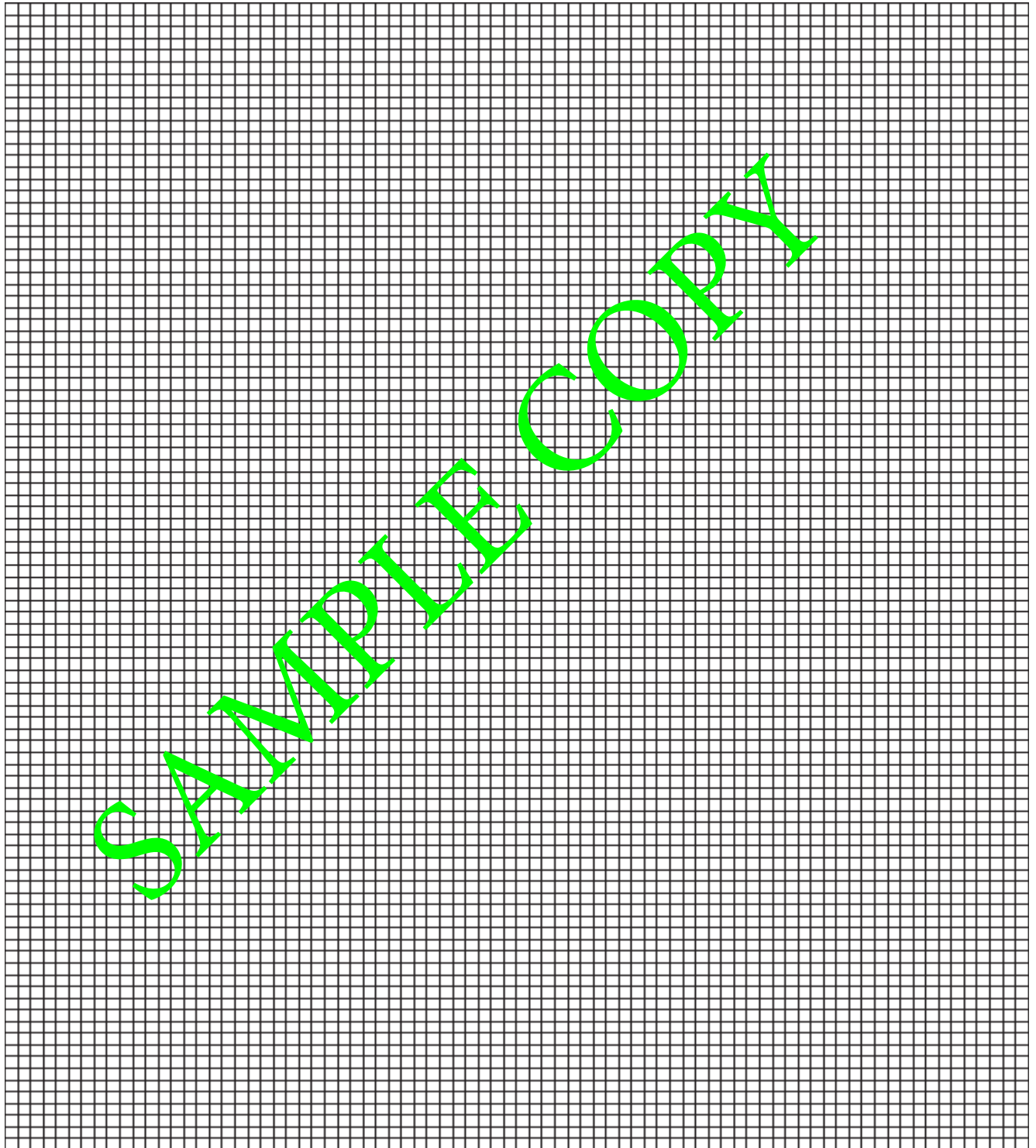

(g) The resistance R_W of the wire is calculated using the equation: $R_W = \frac{22}{N}$

where $N = \frac{V_S}{100G} - 1$

Use your value of V_S recorded in (b) and your value of G calculated in (f) to calculate R_W . Show your working.

$R_W = \dots\dots\dots\Omega$ (01 mark)

Experiment 48

In this experiment you will investigate the resistance of a light-emitting diode (LED).

You are provided with:

- a power supply
- a light-emitting diode
- 5 resistors of resistance 150Ω
- a switch
- connecting wires and crocodile clips.

The supervisor has set up the circuit shown in Figure 48.

The crocodile clip shown in the diagram in Figure 48 is a movable contact that can be attached at different points in the circuit.

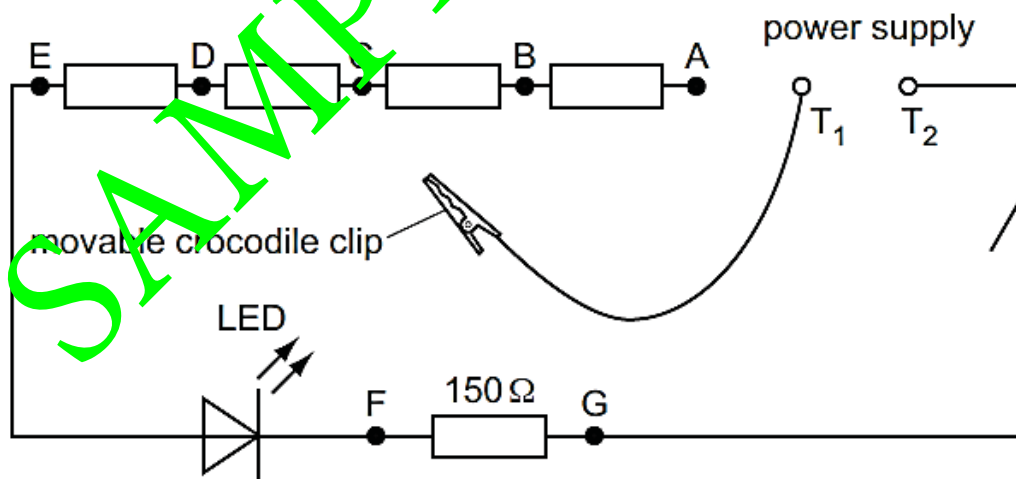

Fig. 48

You are also provided with a voltmeter and two additional connecting wires.

- (a) (i) Make sure that the movable crocodile clip and wire is not touching any other part of the circuit.

Connect the voltmeter between the terminals T_1 and T_2 of the power supply. Record the reading V_S on the voltmeter.

Disconnect the voltmeter from the power supply.

$$V_S = \dots\dots\dots V \text{ (01 mark)}$$

- (ii) Attach the movable crocodile clip to one of the wires either side of the crocodile clip labelled A.

Connect the voltmeter between F and G.

Close the switch.

Record the reading V on the voltmeter.

Open the switch.

$$V = \dots\dots\dots V \text{ (01 mark)}$$

- (iii) Using your answer from (a)(ii), calculate the current I_{LED} in the LED using the equation $I_{LED} = \frac{V}{150}$

$$I_{LED} = \dots\dots\dots A \text{ (01 mark)}$$

- (iv) The total number of resistors connected in series with the LED is n . When the movable crocodile clip is attached by A, the value of n is 5.

Using your answers from (a)(i) and (a)(ii), calculate the voltage V_{LED} across the LED using the equation

$$V_{LED} = V_S - nV.$$

$$V_{LED} = \dots\dots\dots A \text{ (01 mark)}$$

- (v) Using your answers from (a)(iii) and (a)(iv), calculate the resistance R_{LED} of the LED using the equation

$$R_{LED} = \frac{V_{LED}}{I_{LED}}$$

$$R_{LED} = \dots\dots\dots \Omega \text{ (01 mark)}$$

SAMPLE COPY

- (b) (i) In the appropriate row in Table 48, record your readings and calculations from (a)(ii), (iii), (iv) and (v).

Add appropriate headings with units to each column. (01 mark)

- (ii) Repeat the procedure in (a)(ii) to (a)(v) with the movable crocodile clip connected by B, C, D and E.

Record your readings and calculations in Table 48.

Table 48

Position of crocodile clip	n				
by A	5				
by B	4				
by C	3				
by D	2				
by E	1				

(03 marks)

- (c) From the experiment described above, identify: (03 marks)

- (i) The independent variable
- (ii) The dependent variable
- (iii) The constant variable

- (d) Using the grid on next page, plot a graph of R_{LED} (along the vertical axis) against I_{LED} (along the horizontal axis). Draw the curve of best fit. (04 marks)

- (e) The values of the supply voltage and the resistance of the resistors have been carefully selected for use with this LED in this practical exercise.

Suggest two reasons why these values are suitable.

1.
-
2.
-

(04 marks)

SAMPLE COPY

MECHANICAL PROPERTIES OF MATTER

This chapter deals with the behavior of materials used in construction of structures (e.g. bridges, vehicles, dams, roofs etc.) under the action of external forces.

These materials include;

- Timber
- Rubber
- Metals
- Glass
- Concrete
- Bricks
- Plastics
- Stones

Before these materials are used, they are tested under different conditions to see whether they can withstand weather conditions and the action of external forces. The behavior of these materials under test are called mechanical properties.

Definition:

Mechanical properties of matter are the behavior of matter when acted upon by external forces.

These mechanical properties include;

a) STRENGTH:

This is the ability of a material to withstand an applied force before it breaks.

Materials that have this property are said to be strong.

✂ A **strong material** is a material that can withstand a large force before breaking.

Strong materials include; concrete, metals, etc.

Factors that affect the strength of a material

▪ **Magnitude of applied force:**

It is easier for a material to withstand a small force than a large force. Therefore, strength of a material increases when a small force is applied than when a large force is applied.

▪ **Cross-sectional area of a material:**

A material of large diameter (large cross-sectional area) is able to withstand a large force than a material of small diameter.

Therefore, materials with large cross-sectional areas are stronger than material with small cross-sectional areas.

▪ **Nature of the material:**

Different materials withstand different forces before breaking e.g. a steel rod is able to withstand large forces than a piece of wood.

b) STIFFNESS:

This is the ability of a material to resist any force that try to change its shape and size.

OR

This is the ability of a material to resist bending when a force is applied on it.

Materials that have this property are said to be stiff.

✂ A **stiff material** is a material that resists any forces that try to change its shape and size.

Stiff materials are not flexible and they require a large force to be bent.

Stiff materials include; concrete, steel, iron etc.

How to increase the stiffness of a material:

- By reducing the length of a material.
- By reducing the temperature of a material.

c) DUCTILITY:

This is the ability of a material to be changed or molded into different shapes and sizes without breaking.

Materials that have this property are said to be ductile.

✂ A **ductile material** is a material that can be changed or molded into different shapes and sizes without breaking.

Ductile materials are flexible and they can be bent greatly before they break.

Ductile materials include; copper wire, plasticine, rubber etc.

d) BRITTLENESS:

This is the ability of a material to break suddenly without bending when a force is applied on it.

Materials that have this property are said to be brittle.

✂ A **brittle material** is a material that breaks suddenly without bending when a force is applied on it.

Brittle materials are not flexible and they cannot be molded into other shapes. They break easily (fragile) without undergoing plastic deformation.

Brittle materials include; chalk, glass, bricks, dry biscuits, concrete, charcoal, etc.

e) ELASTICITY:

This is the ability of a material to regain its original shape and size when a stretching force is removed.

Materials that have this property are said to be elastic.

✂ An **elastic material** is a material that can regain its original shape and size when a stretching force is removed.

Elastic materials include; rubber springs, etc.

The extension of an elastic material depends on;

→ Nature of a material.

→ Magnitude of stretching force.

f) PLASTICITY:

This is the ability of a material not to regain its original shape and size when a stretching force is removed.

Materials that have this property are said to be plastic (inelastic).

✂ A **plastic material** is a material that cannot regain its original shape and size when a stretching force is removed.

Plastic materials include; plasticine, clay, etc.

HOOKES'S LAW

It states that the extension of a material is directly proportional to force applied provided that the elastic limit is not exceeded.

Force (F) is directly proportional to extension (e)

$$F \propto e$$

$$\boxed{F = Ke}$$

Where;

F —————> Force applied

e —————> Extension

K —————> Spring constant / Proportionality constant / Elastic constant

The SI unit of the spring constant, K is Nm^{-1} .

Extension = New length (l_2) – Original length (l_1)

Examples:

1. A force of 3N is applied on an elastic wire of length 10cm. If its new length after the application of force is 12cm, calculate;

a) Extension.

$$l_2 = 12cm, \quad l_1 = 10cm,$$

$$e = l_2 - l_1$$

$$e = 12 - 10$$

$$e = 2cm$$

b) Elastic constant.

$$e = 2cm = \frac{2}{100} = 0.02m, \quad F = 3N$$

$$F = Ke$$

$$3 = K \times 0.02$$

$$K = \frac{3}{0.02}$$

$$K = 150Nm^{-1}$$

2. A spring extends by 0.5cm when a load of 0.4N hangs on it.

i) Calculate the spring constant.

$$e = 0.5cm = \frac{0.5}{100} = 0.005m, \quad F = 0.4N$$

$$F = Ke$$

$$0.4 = K \times 0.005$$

$$K = \frac{0.4}{0.005}$$

$$K = 80Nm^{-1}$$

ii) Find the force required to cause an extension of 0.06m.

$$F = Ke$$

$$F = 80 \times 0.06$$

$$F = 4.8N$$

NOTE:

✂ If force, F_1 acts on an elastic material, and produces an extension, e_1 and then force, F_2 acts on the same elastic material and produces an extension, e_2 , then;

$$\boxed{\frac{F_1}{e_1} = \frac{F_2}{e_2} \quad \text{or} \quad \frac{F_1}{F_2} = \frac{e_1}{e_2}}$$

Examples:

There is no need of converting units for extension if the two extensions have the same units.

3. A force of 50N causes an extension of 5mm on stretched material. Calculate its extension if a force of 150N is applied.

$$F_1 = 50N, \quad e_1 = 5mm, \quad F_2 = 150N, \quad e_2 = ?$$

$$\frac{F_1}{F_2} = \frac{e_1}{e_2}$$

$$\frac{50}{150} = \frac{5}{e_2}$$

$$e_2 = \frac{150 \times 5}{50}$$

$$e_2 = 15mm$$

4. A mass of 10kg is hang on a spring and it produces an extension of 2cm. What will be the extension if a force of 150N is applied?

$$F_1 = mg = 10 \times 10 = 100N, \quad e_1 = 2cm, \quad F_2 = 150N, \quad e_2 = ?$$

$$\frac{F_1}{F_2} = \frac{e_1}{e_2}$$

$$\frac{100}{150} = \frac{2}{e_2}$$

$$e_2 = \frac{150 \times 2}{100}$$

$$e_2 = 3cm$$

5. When a force of 1N is applied on a spring, the length of the spring increases from 7.4cm to 8.4cm. Calculate;

- a) The elastic constant of the spring.

$$e = (8.4 - 7.4) = 1cm = \frac{1}{100} = 0.01m, \quad F = 1N$$

$$F = Ke$$

$$1 = K \times 0.01$$

$$K = \frac{1}{0.01}$$

$$K = 100Nm^{-1}$$

- b) The extension produced when a force of 50N is applied.

$$F = Ke$$

$$50 = 100 \times e$$

$$e = \frac{50}{100} = 0.5m$$

6. A spring has a natural length of 12cm. When a load P is suspended from it, its length increases to 22cm and when a load of 250N is attached to it, its length increases to 27cm. Find the value of P.

$$F_1 = P, \quad e_1 = (22 - 12) = 10\text{cm}, \quad F_2 = 250\text{N}, \quad e_2 = (27 - 12) = 15\text{cm}$$

$$\frac{F_1}{F_2} = \frac{e_1}{e_2}$$

$$\frac{P}{250} = \frac{10}{15}$$

$$P = \frac{250 \times 10}{15}$$

$$P = 166.8\text{N}$$

7. A mass of 500g causes an extension of 2cm. Calculate the mass that can cause an extension of 0.5cm.

$$m_1 = 500\text{g}, \quad e_1 = 2\text{cm}, \quad m_2 = ?, \quad e_2 = 0.5\text{cm}$$

$$\frac{F_1}{F_2} = \frac{e_1}{e_2}$$

$$\frac{m_1 g}{m_2 g} = \frac{e_1}{e_2}$$

$$\frac{500}{m_2} = \frac{2}{0.5}$$

$$m_2 = \frac{500 \times 0.5}{2}$$

$$m_2 = 125\text{g}$$

EXERCISE:

- A mass of 0.5kg causes a spiral spring to extend by 4cm. Calculate the mass that would cause an extension of 6cm.
- A force of 10N extends a wire by 2cm.
 - Find the constant of proportionality.
 - Find the extension produced by the force of 50N.
- A spring produces an extension of 6mm when a load of 9N is hung from its free end. What load would cause the same spring to stretch by 16mm?
- A metallic cube suspended freely from the end of the spring caused it to stretch by 5cm. 500g mass suspended from the same spring stretched it by 2cm.
 - Find the weight of the metallic cube.
 - By what length will the spring stretch if a mass of 1.5kg is attached to its end?
- A spring stretches by 4mm when supporting a mass of 15kg. By how much would it stretch when supporting a load of 55N?
- A spring increase its length from 20cm to 25cm when a force is applied. If the spring constant is 100Nm^{-1} , calculate the force applied.
- A 5.0cm long spring was used in an experiment. When a load of 2000N is suspended from it, its length increases to 6.5cm and when a load Q is attached to it, its length increases to 8.0cm. Find the value of Q.

8. A vertical spring of length 30cm is stretched to 36cm when an object of mass 100g is placed in the pan attached to it. The spring is stretched to 40cm when a mass of 200g is placed in the pan. Find the mass of the pan.
9. A spring of natural length $8.0 \times 10^{-2}m$ extends by $2.5 \times 10^{-2}mm$ when a weight of 10N is suspended on it.
 - i) Find the spring constant.
 - ii) Determine the extension when a weight of 15N is suspended on the spring.
10. A force of 500N extends a wire by 2mm. If the force is reduced by a half, what will be the new length of the wire if the original length is 10cm.

An experiment to verify Hooke's law

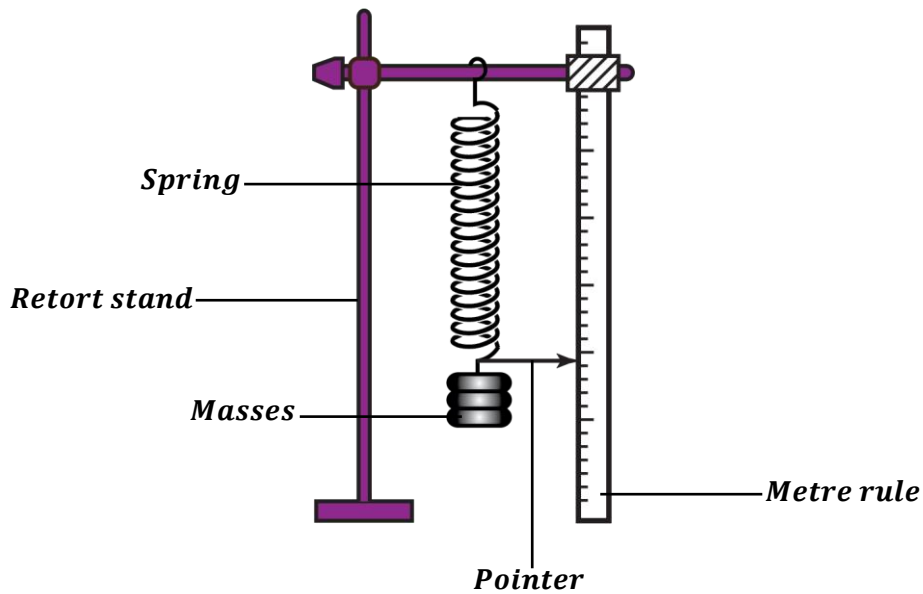

- The experiment is set up as shown above.
- The initial position of the pointer, P_1 is read and recorded.
- A standard mass, m is attached at the end the spring.
- The new position of the pointer, P_2 is read and recorded.
- The extension, e of the spring is determined from the expression, $e = P_2 - P_1$.
- The above procedures are repeated with different masses.
- The results are then put into a suitable table including values of the load (force) i.e. $L = mg$.

$m(kg)$	$L(N)$	$P_2(cm)$	$e(cm)$

- A graph of L against e is plotted.

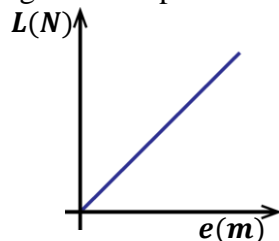

- A straight-line graph through the origin is obtained.
- This shows that L is directly proportional to e hence verifying Hooke's law.

NOTE:

- ✂ In order to get accurate results in the above experiment, the elastic limit of the spring should not be exceeded.

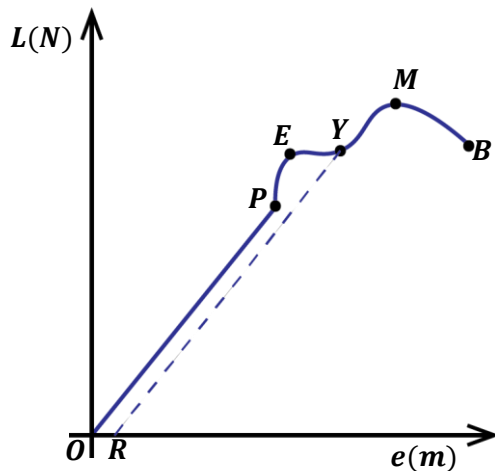
A graph of load against extension for copper wire (ductile material):

P – Proportional limit

E – Elastic limit

Y – Yield point

M – Maximum stress (Breaking stress)

B – Breaking point

OR – Region of permanent deformation

Between O and P:

The extension, e is directly proportional to applied force (Load, L) hence Hooke's law is obeyed in this region. In this region, the material can regain its original shape and size when the stretching force is removed.

Between P and E:

In this region, the material undergoes elastic deformation until it reaches the elastic limit, E . In this region, Hooke's law is not obeyed but the material can regain its original shape and size when the stretching force is removed.

Beyond E:

Point, E , is the elastic limit of the material. Therefore, beyond E , the material undergoes plastic deformation whereby it cannot regain its original shape and size when the stretching force is removed.

The material is permanently stretched between Y and M .

Beyond M:

This point represents the maximum stress a material can withstand (i.e. the maximum load it can handle). Addition of any extra load (force) at this point makes the wire to break on reaching the breaking point B .

IMPORTANT DEFINITIONS
❖ Proportional limit:

This is a point beyond which Hooke's law is not obeyed.

❖ Elastic limit:

This is a point beyond which a material cannot regain its original shape and size when a stretching force is removed.

❖ Yield point:

This is a point beyond which a material is permanently stretched and there is a permanent increase in length when the stretching force is removed.

❖ Elastic deformation:

This is a temporary deformation which occurs before the elastic limit and the material can regain its original shape and size when the stretching force is removed.

❖ Plastic deformation:

This is a permanent deformation which occurs after the elastic limit and the material cannot regain its original shape and size when the stretching force is removed.

TENSILE STRESS, TENSILE STRAIN AND YOUNG'S MODULUS
TENSILE STRESS:

This is the ratio of force applied to the cross-sectional area of a material.

OR

This is the force acting per unit cross-sectional area of a material.

$$\text{Stress} = \frac{\text{Force}}{\text{Cross - sectional area}}$$

$$\text{Stress} = \frac{F}{A}$$

The SI unit of tensile stress is Nm^{-2} (Pascals).

Question: Distinguish between Pressure and Tensile stress.

Pressure is the force acting normally per unit surface area of a material.

WHILE

Tensile stress is the force acting per unit cross-sectional area of a material.

TENSILE STRAIN:

This is the ratio of extension to the original length of the material.

$$\text{Strain} = \frac{\text{Extension}}{\text{Original length}}$$

$$\text{Strain} = \frac{e}{l_1}$$

Tensile strain has no units since extension and original length have the same units.

YOUNG'S MODULUS:

This is the ratio of tensile stress to tensile strain of a material.

$$\text{Young's modulus} = \frac{\text{Tensile stress}}{\text{Tensile strain}}$$

$$\text{Young's modulus} = \frac{F/A}{e/l_1}$$

$$\text{Young's modulus} = \frac{Fl_1}{Ae}$$

The SI unit of Young's modulus is Nm^{-2} (Pascals).

Examples:

1. A copper wire of length 10cm is subjected to a force of 2N. If its cross-sectional area is 5cm^2 and a force causes it to extend by 0.2cm, calculate;
- Tensile stress.
 - Tensile strain.
 - Young's modulus.

$$l_1 = 10\text{cm}, \quad F = 2\text{N}, \quad A = 5\text{cm}^2, \quad e = 0.2\text{cm}$$

- i) Tensile stress

$$A = 5\text{cm}^2 = \frac{5}{10000} = 0.00005\text{m}^2$$

$$\text{Stress} = \frac{F}{A}$$

$$\text{Stress} = \frac{2}{0.00005}$$

$$\text{Stress} = 40,000\text{Nm}^{-2}$$

- ii) Tensile strain

$$\text{Strain} = \frac{e}{l_1}$$

$$\text{Strain} = \frac{0.2}{10}$$

$$\text{Strain} = 0.02$$

- iii) Young's modulus

$$\text{Young's modulus} = \frac{\text{Stress}}{\text{Strain}}$$

$$\text{Young's modulus} = \frac{40000}{0.02}$$

$$\text{Young's modulus} = 5 \times 10^7\text{Nm}^{-2}$$

2. A mass of 2.4kg is attached to the end of a long vertical wire 2m long and produces an extension of 0.5mm. If the diameter of the wire is 0.78mm, calculate;
- Tensile stress.
 - Tensile strain.
 - Young's modulus.

$$m = 2.4\text{kg}, \quad l_1 = 2\text{m}, \quad r = \frac{d}{2} = \frac{0.78}{2} = 0.39\text{mm}, \quad e = 0.5\text{mm}$$

- i) Tensile stress

$$A = \pi r^2 = \frac{22}{7} \times 0.39^2 = 0.478\text{mm}^2$$

$$A = 0.478\text{mm}^2 = \frac{0.478}{1000000} = 4.78 \times 10^{-7}\text{m}^2$$

$$F = mg = 2.4 \times 10 = 24\text{N}$$

$$\text{Stress} = \frac{F}{A}$$

$$\text{Stress} = \frac{24}{4.78 \times 10^{-7}}$$

$$\text{Stress} = 5.02 \times 10^7\text{Nm}^{-2}$$

- ii) Tensile strain

$$e = \frac{0.5}{1000} = 5 \times 10^{-4}\text{m}$$

$$\text{Strain} = \frac{e}{l_1}$$

$$\text{Strain} = \frac{5 \times 10^{-4}}{2}$$

$$\text{Strain} = 2.5 \times 10^{-4}$$

- iii) Young's modulus

$$\text{Young's modulus} = \frac{\text{Stress}}{\text{Strain}}$$

$$\text{Young's modulus} = \frac{5.02 \times 10^7}{2.5 \times 10^{-4}}$$

$$\text{Young's modulus} = 2.0 \times 10^{11}\text{Nm}^{-2}$$

3. A mass of 2000g is placed at the end of the wire 15cm long and cross-sectional area 0.2cm^2 . If the mass causes an extension of 1.5cm, calculate;
- Stress.
 - Strain.
 - Young's modulus.

$$m = 2000\text{g}, \quad l_1 = 15\text{cm}, \quad A = 0.2\text{cm}^2, \quad e = 1.5\text{cm},$$

- i) Stress

$$A = 0.2\text{cm}^2 = \frac{0.2}{10000} = 2.0 \times 10^{-5}\text{m}^2$$

$$F = mg = \frac{2000}{1000} \times 10 = 20\text{N}$$

$$\text{Stress} = \frac{F}{A}$$

$$\text{Stress} = \frac{20}{2.0 \times 10^{-5}}$$

$$\text{Stress} = 1 \times 10^6 \text{Nm}^{-2}$$

- ii) Strain

$$\text{Strain} = \frac{e}{l_1}$$

$$\text{Strain} = \frac{1.5}{15}$$

$$\text{Strain} = 0.1$$

- iii) Young's modulus

$$\text{Young's modulus} = \frac{\text{Stress}}{\text{Strain}}$$

$$\text{Young's modulus} = \frac{1 \times 10^6}{0.1}$$

$$\text{Young's modulus} = 1.0 \times 10^7 \text{Nm}^{-2}$$

4. A piece of wire of diameter 0.64mm and length 12m is stretched through 2.5cm by a 5kg mass.
- a) Determine the;

$$A = \pi r^2 = \frac{22}{7} \times \left(\frac{0.64}{2}\right)^2 = 3.218 \times 10^{-1} \text{mm}^2$$

$$A = 3.218 \times 10^{-1} \text{mm}^2 = \frac{3.218 \times 10^{-1}}{1000000} = 3.218 \times 10^{-7} \text{m}^2$$

$$F = mg = 5 \times 10 = 50\text{N}$$

$$\text{Stress} = \frac{F}{A}$$

$$\text{Stress} = \frac{50}{3.218 \times 10^{-7}}$$

$$\text{Stress} = 1.554 \times 10^8 \text{Nm}^{-2}$$

- b) What force will stretch the wire through 4cm?

$$\frac{F_1}{F_2} = \frac{e_1}{e_2}$$

$$\frac{50}{F_2} = \frac{2.5}{4}$$

$$F_2 = \frac{50 \times 4}{2.5}$$

$$F_2 = 80\text{N}$$

5. A material stretched by 6cm develops a strain of 4.8×10^{-2} . Find the original length of the material.

$$e = 6\text{cm}, \quad \text{strain} = 4.8 \times 10^{-2}$$

$$\text{Strain} = \frac{e}{l_1}$$

$$4.8 \times 10^{-2} = \frac{6}{l_1}$$

$$l_1 = 125\text{cm}$$

EXERCISE:

- Calculate the tensile stress when a force of 25N acts on a wire of cross-sectional area 5m^2 .
- The breaking stress of a material is $4.0 \times 10^6 \text{Nm}^{-2}$. Calculate the force required to break a piece of material of cross-sectional area 10m^2 .
- A string 4mm in diameter has original length 2m. The string is pulled by a force of 200N. If the final length of the spring is 2.02m, determine;
 - Stress.
 - Strain.
 - Young's modulus.
- A piece of wire of diameter 0.32mm and length 14m is stretched through 2.8cm by a 10kg mass.
 - Determine the young's modulus of the material.
 - What force will stretch the wire through 12cm?
- An elastic material of cross-sectional area 32m^2 is 4m long. When a force of $1.6 \times 10^5 \text{N}$ is applied to the material, its length increases by 1mm. Calculate;
 - The stress in the material.
 - The strain in the material.
- A mass of 200kg is placed at the end of the wire 15cm long and cross-sectional area 0.2cm^2 . If the mass causes an extension of 1.5cm, calculate the young's modulus of the material.

COMPRESSION AND TENSILE FORCES
Compression forces:

When compression forces act on a material, they cause the particles of the material to be pressed more closely together. This causes a decrease in length of a material but the thickness of the material increases.



Tensile forces:

When tensile forces act on a material, they cause the particles of the material to be pulled further apart from one another. This causes an increase in length of a material but the thickness of the material decreases.

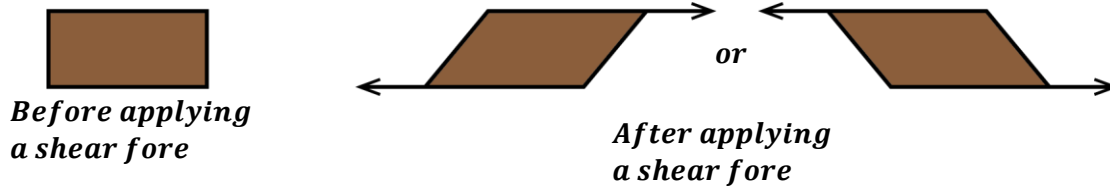

SHEAR FORCE:

A shear force is the force needed to fracture the material in direction parallel to applied force. A shear force is produced when two equal but opposite forces are applied on the body. Shear forces causes a body to be twisted and deformed.

**CONSTRUCTION MATERIALS**

In Uganda, some of the important building or construction materials today are natural stones, timber, glass, bricks, concrete, iron bars, iron sheets, etc.

NATURAL STONES:

These are inorganic minerals quarried from the earth's surface.

These natural stones occur in form of basalt, flint, granite, limestone, marbles, sand stones, slate, quartzite, limestone, etc.

BRICKS OR BLOCKS:

Bricks are made by mixing clay and water together. The mixture is then molded into different shapes and then fired in a kiln at high temperatures.

Bricks are hard, stiff, brittle and strong under compression.

MORTAR:

Mortar is a mixture of sand and cement made into paste by adding water. It is used for bonding bricks

METALS:

These are used in construction of different structures e.g. ships, vehicles, buildings, etc.

Metals can be deformed into different shapes and sizes depending on the construction to be made.

Metals are usually stronger and durable when compared to timber.

Common metals used in construction include; iron for making iron sheets and nails, steel, etc.

TIMBER:

It is used for making furniture used to make scaffolds, bridges, bodies of vehicles, ceiling boards, etc.

Advantages of timber as a construction material

- It is cheap.
- It is durable when seasoned and treated well.
- It is easy to work with.

Disadvantages of timber as a construction material

- It is not fire resistant.
- It can get rotten if not treated and seasoned well.

Glass:

Glass is a magical construction material as it has various applications in doors and windows because of its desirable properties.

Properties of glass that make it a desirable building material:

- It is transparent.
- It is weather resistance i.e. it can withstand the effects of rain, sun, wind.
- It is heat resistant i.e. its an insulator to heat.
- It is chemical resistant i.e. few chemicals can react with it.
- Its surface is hard and difficult to scratch.
- It is fire resistant.

Disadvantages of timber as a construction material

→ Glass is brittle i.e. it can break immediately when a maximum force is applied.

CONCRETE:

Concrete is a proportioned mixture of cement, sand, gravel (small stones) and water.

Concrete is used where heavy loads have to be supported e.g. in foundations of tall buildings, dams, etc.

✂ Since concrete is a brittle material it is weak under tension (tensile forces) but strong under compression.

Properties of concrete which make it a desirable building material

- It is weather resistant.
- It is fire resistant.
- It is strong under compression.
- It is durable i.e. it can be used for a long period of time.

NOTE:

✂ Although concrete is a desirable building material, it is unsuitable for use in structures under tension since it has a small tensile strength (weak under tension). Therefore, to increase the tensile strength of concrete, it has to be reinforced.

REINFORCED CONCRETE:

Reinforced concrete is concrete obtained by combining concrete with materials that have a high tensile strength e.g. steel or iron bars, wire mesh, wooden strands, etc.

Question: State any materials that maybe used to reinforce concrete.

- *Steel rods*
- *Wire mesh*
- *Iron bars*
- *Wooden stands*

Advantages of reinforced concrete

- It is strong under compression and under tension.
- It is weather resistant.
- It is fire resistant.
- It is durable.
- It has much greater ductility when still wet.

STRUCTURES AND BEAMS

A **structure** is a make-up which consists of pieces of materials that are joined together. In order to construct a structure that will be durable, beams and girders are put into use.

BEAMS:

A **beam** is a large and long piece of material used to provide main support to the structure. Without a beam, a structure is unable to withstand the compressional and tensile forces.

NOTE:

- ✧ When a beam bends, one side of the beam is compressed (under compression) and the other side is stretched out (under tension) but the centre of the beam is not stretched or compressed (neutral).

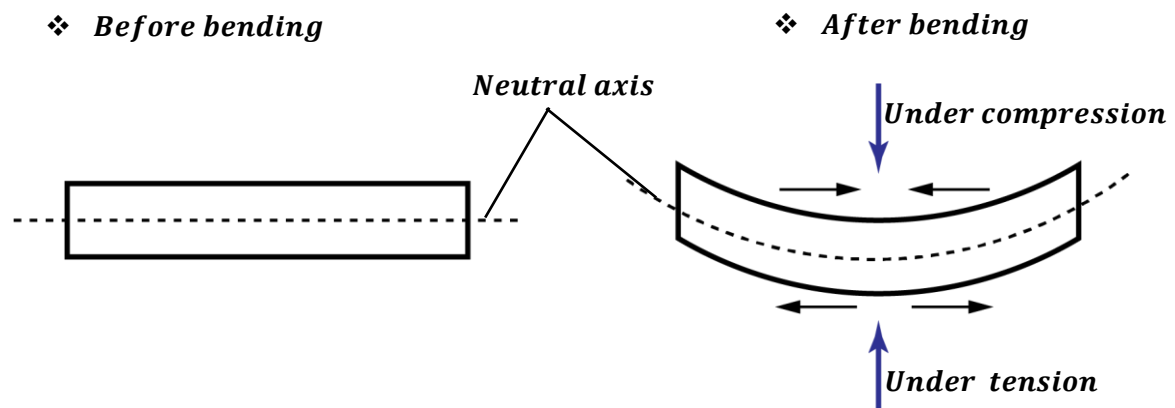

From the diagram, the neutral axis is the central region of a beam that is not affected by either compression or tensile forces. Therefore, if removed, the tensile and compressive strength of the beam increases since less material is stuck in the middle.

This explains why pipes used in construction of structures are made hollow.



Advantages of hollow beams:

(Why are pipes used in construction of structures like bicycles and bridges are made hollow?)

- They can withstand both compression and tensile forces.
- Notches cannot spread easily thus there is less risk of breaking.
- They are light.
- They are economical since less material is used for construction.
- Structures can expand and contract easily.

NOTCHES AND CRACKS:

A **notch** is a cut or a weak point on a material.

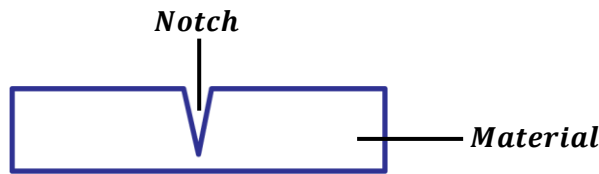

Notches and cracks spread more easily when a material is under tension than when it is under compression.

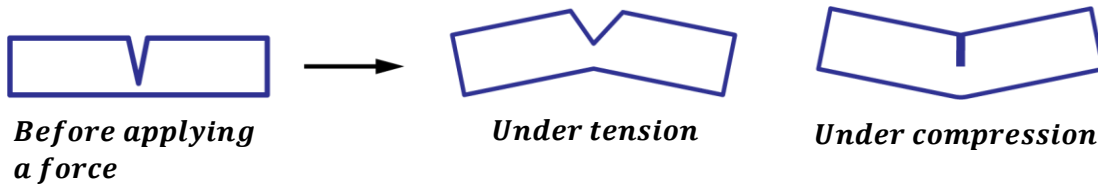
How a notch weakens a beam of a brittle material:

When a tensile (tensional) force is applied on a brittle material like glass with a notch, it will cause a notch to be stretched (under tension) causing it to widen further hence weakening the material.

Question: Explain why in bridge, a beam with a notch lasts longer when a notch is on the top surface than when the notch is on the lower surface.

When a notch is on the top surface of beam, it is under compression. Therefore, it doesn't spread easily since it can withstand compressional forces thus making it stronger in this case.

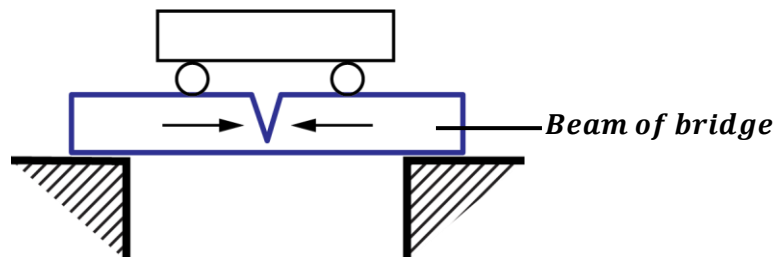

When a notch is the lower surface of the beam, it is under tension. Therefore, it spreads easily since it cannot withstand tensional forces thus making it weak in this state.

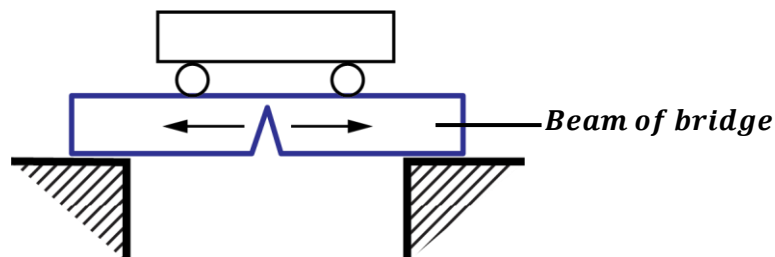
Methods of reducing notch effect:

- Structures are designed in such a way that all parts are under compression.
- Structures are laminated. i.e. layers of a structure are joined together e.g. tables are covered with plywood on their top surfaces and pieces of timber are glued to get a stronger one.
- Surfaces of structures e.g. made as smooth as possible

Applications of the notch effect:

- Some papers like bank slips are designed in such a way that they perforations (notches) to separate them easily.
- Notches or cracks are put on glass so that it can easily cut into pieces.

STRENGTH AND TYPES OF STRUCTURES

There are many types and shapes of structures commonly used in Uganda. The type and shape of a structure determines its strength.

The common types of structures include;

a) Rectangular structures:

These are made in form of a rectangle.

They are less rigid and weak compared to others. Therefore, they can easily collapse.

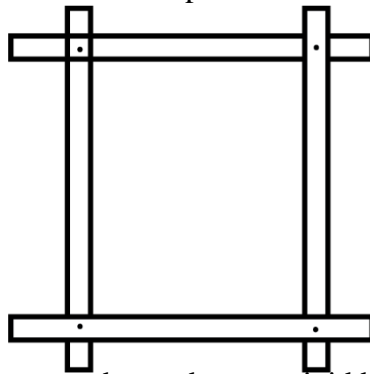

Rectangular structures can be made more rigid by placing a beam along one of its diagonals.

b) Triangular structures:

These are made in form of a triangle.

They are more rigid and strong compared to others. Therefore, they cannot easily collapse.

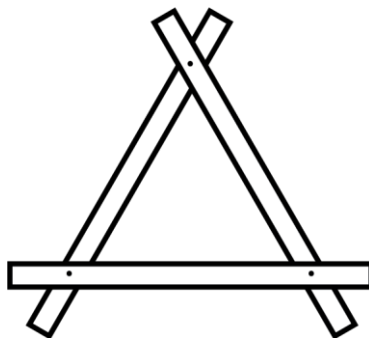

Since triangular structures are strong and rigid, this explains why structures like doors, house roofs, water tanks are made with triangular shapes.

GIRDERS

A girder is a piece of material which strengthens a structure.

In a structure, some girders are under tension and others are under compression.

TIES AND STRUTS:

Tie: This is a girder under tension.

Ties can be replaced by strings.

Strut: This is a girder under compression.

How to identify ties and struts in a given structure:

- Remove each of the girder one at a time from the structure and observe the effect it causes on the points that were joined by that girder.
- If the points that were joined by the girder move further apart, then the girder is a tie.
- If the points that were joined by the girder move closer together, then the girder is a strut.
- Always note that the weight of the structure acts downwards.

NOTE:

- ✂ Therefore, the functions of ties prevent the points they join from moving further away and struts prevent the points they join from moving closer together.

Examples:

1. The figure below shows a structure of a bridge. Identify the ties and struts in the structure.

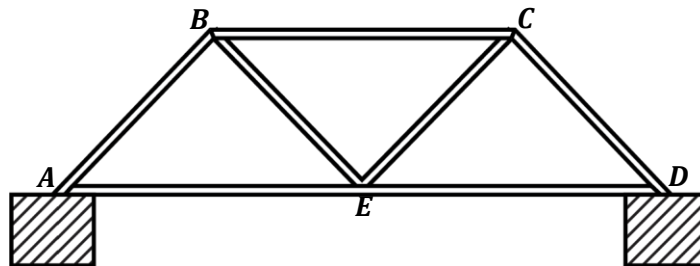

In order to determine each of the girders whether they are struts or ties, each of the girders is removed and the effect noted.

- ❖ When BC is removed, point B moves close to point C. Then girder BC is a strut.
- ❖ When AB is removed, point A moves close to point B. Then girder AB is a strut.
- ❖ When CD is removed, point C moves close to point D. Then girder CD is a strut.
- ❖ When BE is removed, point E moves further away from point B. Then girder BE is a tie.
- ❖ When CE is removed, point E moves further away from point C. Then girder CE is a tie.
- ❖ When AE is removed, point A moves further apart from point E. Then girder AE is a tie
- ❖ When ED is removed, point E moves further apart from point D. Then girder ED is a tie

2. Identify the girders in the structure below.

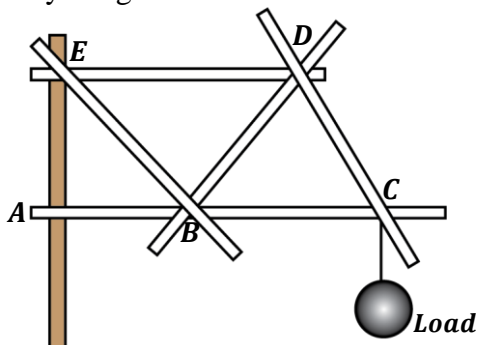

ED – Tie
DC – Tie
BC – Strut
AB – Strut
EB – Strut
BD – Strut

- ❖ When ED is removed, the structure will bend at B. Therefore, D moves further away from E. Then ED is a tie.
- ❖ When DC is removed, the load pulls point C downwards. Therefore, C moves further away from D. Then DC is a tie.
- ❖ When BC is removed, the load pulls point C to come close to point B. Then BC is a strut.
- ❖ When AB is removed, the structure bends at E. Therefore, point B moves close to A. then AB is a strut.
- ❖ When BD is removed, points E, D, C will become straight thus making point D to come closer to B. Then BD is a strut. Similarly, BE is a strut.

3. The diagram below shows a structure firmly fixed on the wall. Identify the ties and struts.

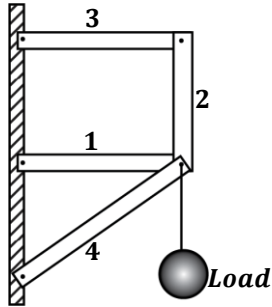

- 1 – **Strut**
- 2 – **Tie**
- 3 – **Tie**
- 4 – **Strut**

4. The diagram below shows an arm of a crane used to carry a load. Name the forces acting on the structure.

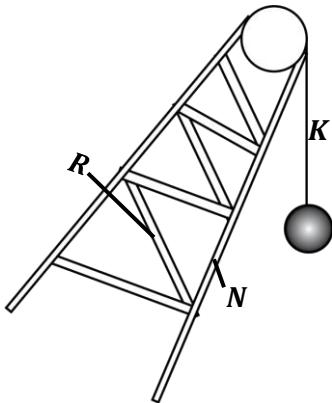

- K – Strut force**
- R – Compression force**
- N – Compression force**

5. The diagram shows the framework of a bicycle.



Which of the parts labelled M, N, R and Q would be in;

a) tension.

Q and R

b) compression when a heavy person sits on the seat.

M and N

Applications of struts and ties:

- They are used in roof supports.
- They are used in communication masts.
- They are used in construction of bridges.
- They are used to support water tanks.

EXERCISE:

1. The figure below shows part of a roof structure.

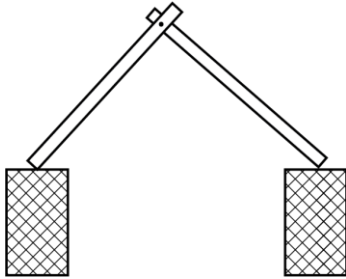

- a) Copy the diagram and on it show how the structure can be strengthened by using two other girders.
- b) Label one tie and one strut on your diagram.

2. Explain the functions of the following girders in a structure.

- a) Struts.
- b) Ties.

3. The diagram below shows a structure of a simple bridge.

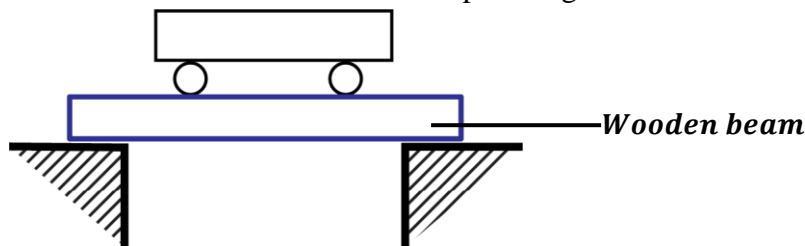

- i) Mark the neutral axis of the beam.
 - ii) Explain the mechanical state of the beam.
 - iii) What would be the effect on the beam if a notch is made on the lower side of the beam.
 - iv) Indicate on the diagram how the bridge can be strengthened.
4. a) With the aid of a diagram, describe the effect of a shear force on the body.
 - b) State any three characteristics of concrete which make it a desirable building material.
 - c) State any three reasons why the pipes used in the structures of bicycles are made hollow.
 5. a) Many construction materials are commonly used in Uganda.
 - i) State one advantage of glass as a construction material.
 - ii) Explain briefly how concrete maybe improved so that it can withstand tensional forces.
 - c) In construction of bridges, hollow cubes of strong metals are used instead of the solid ones. What advantages do those bridges have?
 6. Identify the ties and struts in the following diagrams.

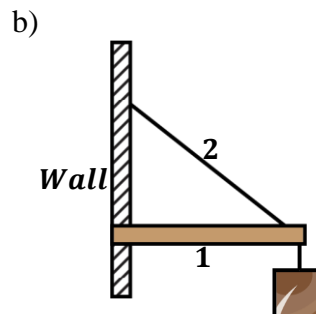
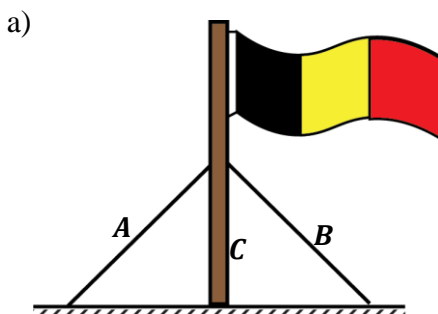

7. The figure below shows an arrangement of three planks on a vertical frame.

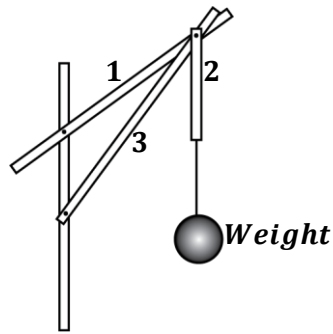

State the planks that can be replaced by strings or ropes.

8. The diagram below shows the structure of a bridge.

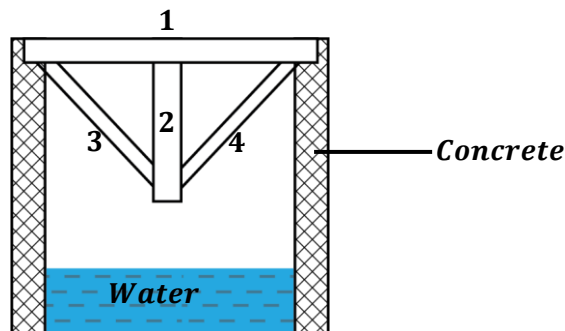

- Name the types of force that acts along the parts 1, 2, 3 and 4 when the bridge has been loaded at the centre.
 - Name one material in each case that can be used to construct parts 2 and 4. Give a reason for your answer.
9.
 - Define the term “notch” as used in construction.
 - State three ways of reducing notches in beams.
 - Describe the advantages of reinforcing concrete.
10. The following readings were obtained in an experiment to verify Hooke’s law when a spring was extended by hanging various masses on it.

Mass (g)	0	25	50	75	100	125
Extension (cm)	10.0	11.5	12.5	13.5	14.4	16.0

Plot a graph of mass against extension and use it to determine.

- The mass when the extension is 12cm.
- The extension for 0.02kg.

PARTICULATE NATURE OF MATTER**Definition:**

Matter is anything that occupies space and has weight.

States of matter

There are three states of matter namely;

- Solids e.g. stone, wood, ice, etc.
- Liquids e.g. milk, water, paraffin, etc.
- Gases e.g. oxygen, nitrogen, etc.

Each of the above particles is made up of tiny particles called molecules.

Properties of the states of matter:**a) SOLIDS:**

- Molecules in solids are closely packed together.
- Solids have a definite shape.
- Solids have a definite volume.
- The intermolecular forces between molecules of a solid are very strong.
- Solids are incompressible. i.e. their volumes cannot be reduced by squeezing.

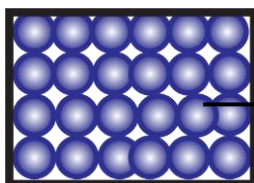

Solid molecules

b) LIQUIDS:

- Molecules in liquids are fairly closely packed together.
- Liquids do not have a definite shape. They take the shape of the container in which they are put.
- Liquids do not have a definite volume. They take the volume of the container in which they are put.
- The intermolecular forces between molecules of a liquid are relatively weak compared to those of solids.
- Liquids are incompressible. i.e. their volumes cannot be reduced by squeezing.

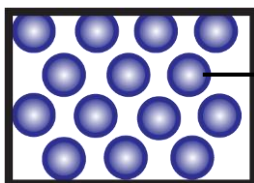

Liquid molecules

c) GASES:

- Molecules in gases are widely spaced.
- Gases do not have a definite shape. They take the shape of the container in which they are put.
- Gases do not have a definite volume. They take the volume of the container in which they are put.

- The intermolecular forces between molecules of a gas are very weak compared to those of solids and liquids.
- Gases are compressible. i.e. their volumes can be reduced by squeezing.

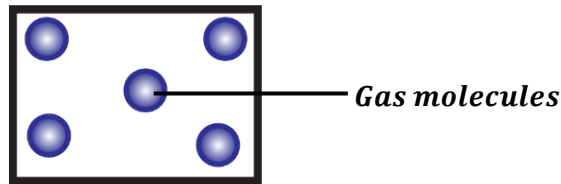

Question: Explain how it is possible to compress gases than solids.

This is because the molecules of gases are widely spaced (have free spaces in between them) and the intermolecular forces between them are very weak. Therefore, if there is squeezing of the molecules of a gas, also the free spaces are occupied by the squeezed molecules thus reducing the amount of space occupied by these molecules.

EFFECT OF HEATING MATTER:

- When a solid is heated, its molecules gain kinetic energy and their speed is increased thus vibrating more violently. This weakens the intermolecular forces of attraction and repulsion between the solid molecules hence they start to separate. This causes a solid to change to liquid.

Question 1: Explain why ice melts to liquid when it is placed under sunshine.

This is because that the sun rays from the sun heats up the ice causing the molecules of ice to gain kinetic energy thus increasing their speeds. This causes them to vibrate more violently thus breaking or weakening the intermolecular forces between them hence causing ice to melt to liquid.

- When a liquid is heated, its molecules gain kinetic energy and their speed is increased thus vibrating violently. This weakens the intermolecular forces of attraction and repulsion between the liquid molecules. This causes a liquid to boil and change to vapour.

Question 2: Explain vapour is seen when water is boiled

This is because when water is heated, its molecules gain kinetic energy thus increasing their speeds. This causes them to vibrate more violently thus breaking or weakening the intermolecular forces between them hence causing some molecules to escape from the surface of the liquid which are seen as vapour.

EFFECT OF COOLING MATTER:

- When a gas or vapour is cooled, its kinetic energy reduces hence the speed of its molecules also reduces. This causes the intermolecular forces between the gas molecules to start to build up. Therefore, the gas changes to a liquid.

On further cooling, the liquid changes to a solid.

CHANGES OF STATES OF MATTER

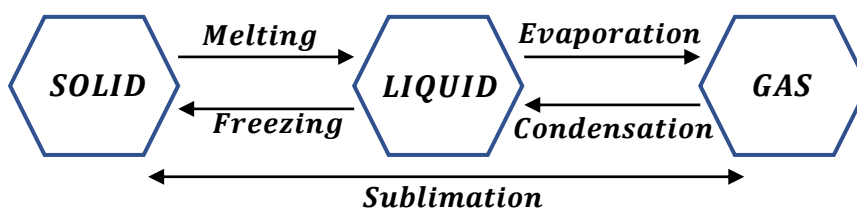

Melting: This is a process by which a solid change to a liquid. It occurs at a constant temperature called melting point.

Evaporation: This is a process by which a liquid change to a gas. It occurs at a constant temperature called boiling point.

Freezing: This is a process by which a liquid change to a solid. It occurs at a constant temperature called freezing point.

Condensation: This is a process by which a gas change to a liquid.

Sublimation: This is a process by which a solid change to a gas or a gas changes to a solid.

KINETIC THEORY OF MATTER

It states that matter is made up of small particles called molecules that are in a state of continuous random motion and increase in temperature increases their speed.

Matter possesses kinetic energy due to the continuous movement of its molecules. The kinetic theory of matter can be proved by Brownian motion or diffusion.

BROWNIAN MOTION:

This was illustrated by an English man called Robert Brown.

Definition:

Brownian motion is the continuous random movement of molecules of fluids.

An experiment to demonstrate Brownian motion using a smoke cell.

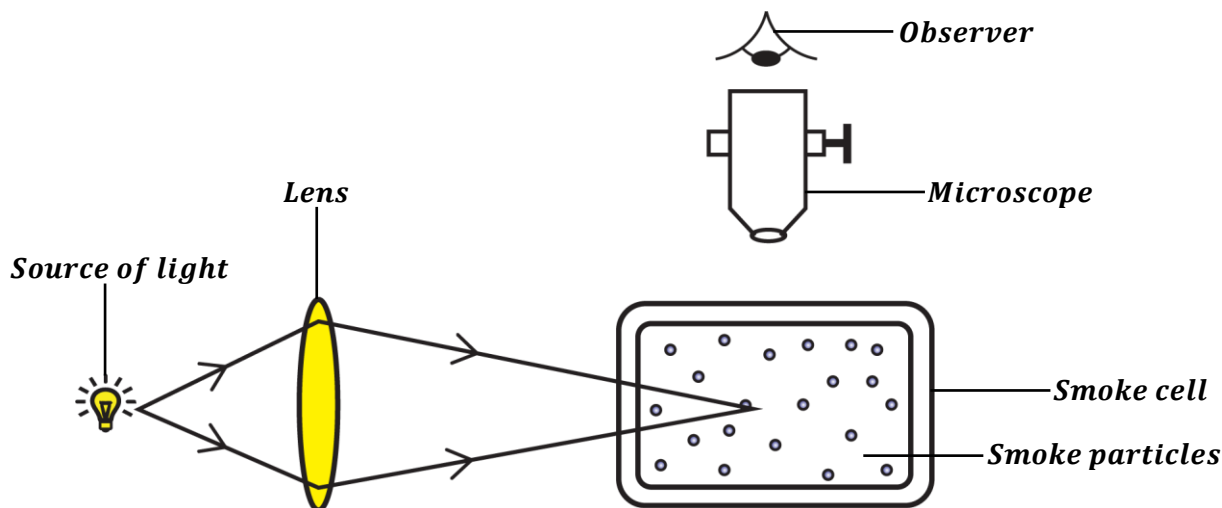

Procedures:

- Smoke particles are put in a smoke cell.
- The smoke particles are illuminated by a source of light from one side of the smoke cell.
- The smoke particles are then viewed using a microscope placed above the smoke cell.

Observation:

- The smoke particles are seen moving in a continuous random motion.

Explanation:

- The continuous random motion of the smoke particles is due to collision with the air molecules in the smoke cell which are also in a constant random motion.

NOTE:

- Brownian motion in liquids can be demonstrated by using a glass container containing water with some pollen grains in it instead of a smoke cell. The pollen grains will also be seen moving with a constant or continuous random motion.

EFFECT OF TEMPERATURE ON BROWNIAN MOTION**→ Increasing the temperature (heating):**

When the temperature of the smoke cell is increased, the smoke particles are seen moving faster and more randomly.

This is because the increase in temperature causes the kinetic energy of the smoke particles to also increase thus increasing their speed. This makes the smoke particles to move faster than before.

→ Decreasing the temperature (cooling):

When the temperature of the smoke cell is decreased (e.g. by placing the smoke cell in ice cubes), the smoke particles are seen moving slowly and less randomly.

This is because the decrease in temperature causes the kinetic energy of the smoke particles to also decrease thus reducing their speed. This makes the smoke particles to move slower than before.

EXERCISE:

1. Smoke is enclosed in a cell and then viewed through a microscope.
 - a) Explain what is observed.
 - b) State what is observed when the smoke cell is placed in ice blocks. Give a reason for your answer.
2. Dust was introduced in a room with yellow light.
 - a) Explain what was observed.
 - b) Explain what happens when the temperature of the room is increased.
3.
 - a) What is meant by the term “Brownian motion”.
 - b) Describe an experiment to demonstrate Brownian motion in liquids.
4. Describe the relationship between molecules of liquids, gases and solids in terms of;
 - a) The arrangement of molecules.
 - b) The separation of the molecules.
 - c) The forces of attraction between the molecules.
 - d) The compressibility of the three states of matter.
5. Draw a well labelled diagram you would use to describe Brownian motion using smoke.
 - a) How is the motion of the smoke particles best described?
 - b) Account for the motion of the smoke particles in (a) above.

MOLECULAR PROPERTIES OF MATTER

The molecular properties of matter are as a result of the behavior of its molecules.

The behavior of molecules is seen in the following processes.

- Diffusion.
- Intermolecular forces.
- Capillarity.
- Surface tension.

DIFFUSION:

When a rotten egg is placed in one corner of a class room, the entire class room and even those in the far corners can notice the bad smell of the rotten egg.

This is because the smell is spreading or moving from where it was put to the other areas of the classroom.

Definition:

Diffusion is the movement of molecules from a region of high concentration to a region of low concentration.

An experiment to demonstrate diffusion in liquids.

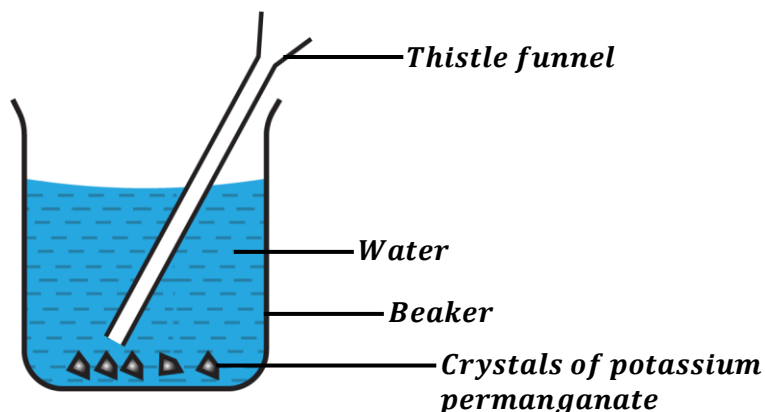

Procedures:

- A beaker is filled with water.
- Some crystals of potassium permanganate (purple crystals) are placed at the bottom of the beaker using a thistle funnel.

Observation:

- It is observed that the crystals of potassium permanganate dissolve in water and they spread throughout the water forming a purple solution.

Explanation:

- The whole water becomes purple because the molecules of potassium permanganate have diffused into water from the bottom (high concentration) to the top (low concentration).

NOTE:

- Another coloured substance that can be used is copper (ii) sulphate crystals (blue crystals). The solution becomes blue if they are dissolved in water.

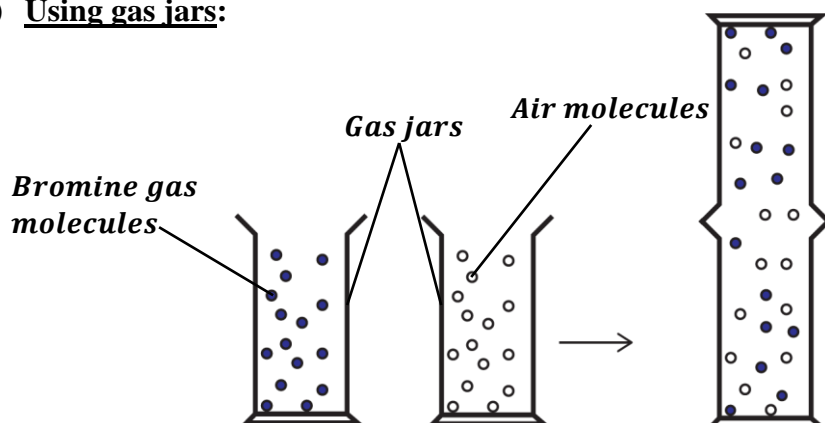
An experiment to demonstrate diffusion in gases.
a) Using gas jars:

- Two gas jars of the same diameter are obtained.
- One gas jar is filled with a coloured gas e.g. bromine gas (brown in colour) and the other gas jar is filled with air molecules.
- The gas jar containing air is inverted on the open end of the gas jar containing bromine gas.
- It is observed that after sometime, the brown colour of bromine gas is seen spreading into the gas jar containing air.
- This shows that brown bromine gas is diffusing from the gas jar where it is more concentrated to the gas jar where it is less concentrated.

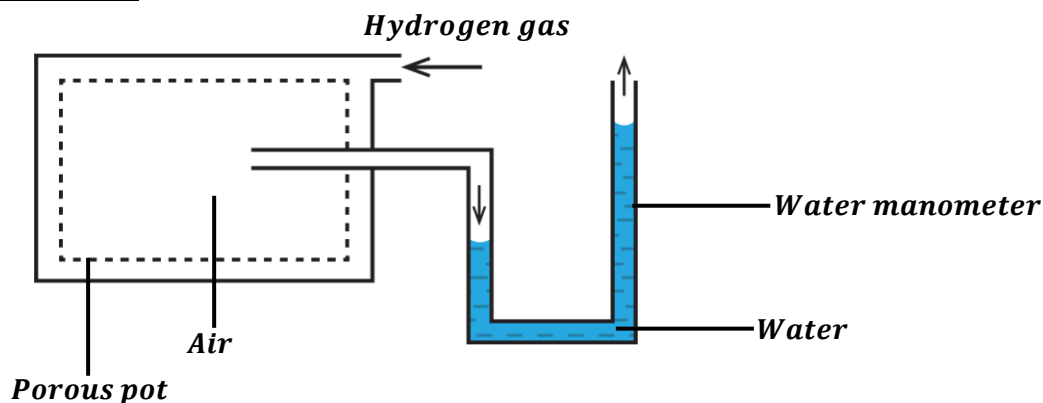
b) Using a porous pot:

Procedures:

- A water manometer is connected to a porous pot containing water.
- Hydrogen gas is passed into the air enclosed in the porous pot as shown above.

Observation:

- It is observed that the water level in the left arm of the manometer falls while that in the right arm of the manometer rises.

Explanation:

- This shows that hydrogen gas molecules diffuse through the porous pot hence increasing the pressure on the surface of water in the manometer thus pushing water down in the left arm. This causes a rise in water in the right arm of the manometer.

FACTORS THAT AFFECT THE RATE OF DIFFUSION**1. Temperature:**

The rate of diffusion is directly proportional to the temperature.

Therefore, the rate of diffusion increases with an increase in temperature and decreases with a decrease in temperature.

This is because when temperature is increased, the speed of molecules increases thus spreading faster and when the temperature is lowered, the speed of molecules decreases thus spreading at a slow rate.

This explains why the smell from a latrine spreads faster during a dry day.

2. Size of diffusing molecules:

Smaller molecules diffuse faster than larger molecules. This is because large molecules occupy more space than the small molecules thus it becomes difficult for them to pass through a material with small pores.

3. Pressure:

The rate of diffusion is directly proportional to the pressure.

Therefore, the rate of diffusion increases with an increase in pressure and reduces with a decrease in pressure.

This is because when pressure is increased, the molecules are highly squeezed thus causing them to collide more frequently hence making them to move faster.

4. Density of the gas molecules:

The rate of diffusion is inversely proportional to the density of gas molecules.

Therefore, the higher the density, the lower the rate of diffusion and the lower the density, the higher the rate of diffusion.

Lighter molecules diffuse faster than heavier molecules.

5. Concentration of diffusing material:

The higher the concentration of a diffusing material, the higher the rate of diffusion and the lower the concentration of a diffusing material, the lower the rate of diffusion.

This explains why more concentrated sugar at the bottom of the cup spreads faster in porridge than a low concentration of sugar at the bottom.

6. Size of pores in the porous material:

Large pores of a porous material allow many molecules to pass through them per unit time while small pores allow very few molecules to pass through them. As a result, the rate of diffusion is high when the size of pores is large and low when the size of pores is small.

NOTE:

✂ Diffusion is fastest in gases, relatively faster in liquids and very slow in solids. In liquids and gases, particles or molecules move randomly from place to place. These particles collide with each other thus changing directions. Eventually, the particles are spread through the whole container.

✂ Diffusion is faster in gases because gas molecules are widely spaced therefore, the intermolecular forces between them are very weak thus the molecules can easily move randomly from place to place.



EXERCISE:

1. Explain the following observations in daily life.
 - i) A small amount of perfume sprayed at one corner of a room spreads quickly and fills the whole room.
 - ii) The smell from a pit latrine spreads faster to the surrounding areas on a dry day.
 - iii) If you put much sugar in tea, the tea will become sweet even if you don't stir it.
2.
 - a) What is meant by the term diffusion?
 - b) Describe an experiment to show diffusion in liquids.
 - c) A porous pot containing air is connected to a water manometer. Explain what happens if hydrogen gas is let in the space surrounding it.
3. The figure below shows an arrangement to demonstrate diffusion.

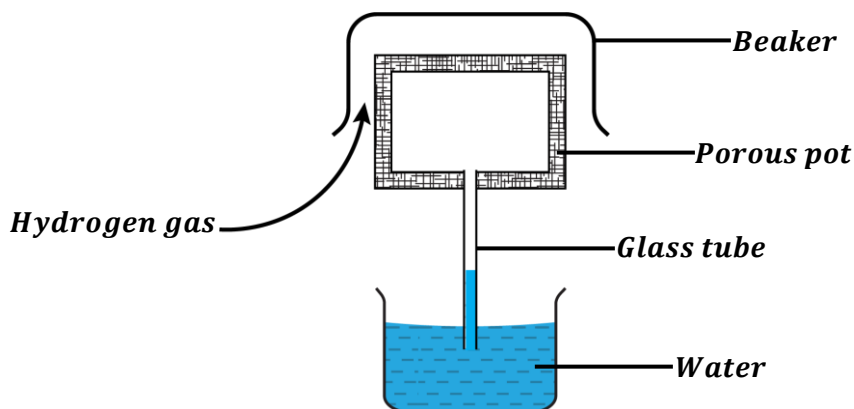

Hydrogen gas is supplied for some time and then stopped. State and explain what is likely to be observed when hydrogen gas supply;

- a) is on.
- b) is stopped.

INTERMOLECULAR FORCES:

Molecular forces are forces of attraction or repulsion between molecules of matter.

These molecular forces hold molecules of matter. They become weak as temperature of matter is increased.

The molecular forces include;

- cohesion forces.
- Adhesion forces.

COHESION FORCES:

These are forces of attraction between molecules of the same substance or same kind.

E.g.:

- Forces of attraction between a water molecule and another water molecule.
- Forces of attraction between glass molecules themselves.

ADHESION FORCES:

These are forces of attraction between molecules of different substances.

E.g.:

- Forces of attraction between a water molecule and a glass molecule.
- Forces of attraction between mercury molecules and paraffin molecules.

EFFECTS OF ADHESION AND COHESION FORCES

The magnitude of cohesive and adhesive forces determines;

- The ability of a liquid to wet another material.
- Shape of meniscus of the liquid.
- The rise or fall of a liquid in the capillary tube.

When adhesion forces are greater than cohesion forces (e.g. water and glass molecules):

The forces of attraction between water molecules and molecules of other substances e.g. glass (adhesive forces) are greater than the forces of attraction between water molecules themselves (cohesive forces).

This explains the following observations:

- ✂ When water is spilled (poured) on a clean glass surface, water spreads out and wets the glass.

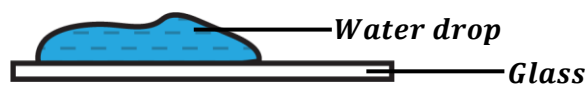

- ✂ When water is poured in a clean container, the meniscus of water curves upwards.

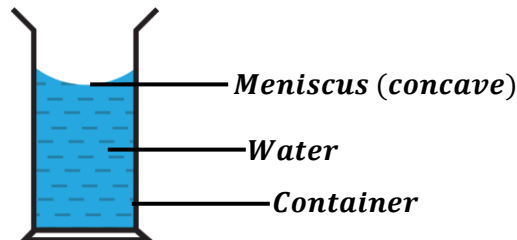

When cohesion forces are greater than adhesion forces (e.g. mercury molecules):

The forces of attraction between mercury molecules themselves (cohesive forces) are greater than the forces of attraction between mercury molecules and molecules of other substances (adhesive forces).

This explains the following observations:

- ✂ When mercury is spilled (poured) on a clean glass surface, mercury forms small spherical droplets and doesn't wet the glass.

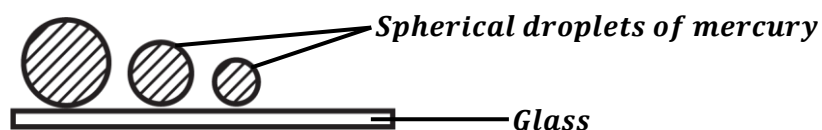

- ✂ When mercury is poured in a clean container, the meniscus of mercury curves downwards.

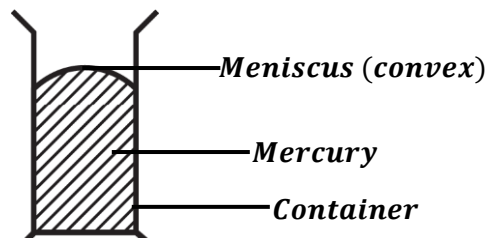

Question 1: Explain why when water is poured on glass, water wets it.

Water spreads on the glass surface due to greater adhesion forces between glass and water molecules than the cohesion forces between water molecules themselves hence wetting the glass.

Question 2: Explain why rain falls in droplets rather than a fine mist.

This is because water has very strong cohesive forces which pulls its molecules tightly together forming droplets.

Revision questions:

1. Explain why water in a narrow glass tube has a concave meniscus (curves upwards) while mercury, in the same tube has a convex meniscus (curves downwards).
2. Explain why when washing glass utensils, water remains attached to the utensils.

CAPILLARITY:

When a wick of a lamp is placed in paraffin, paraffin rises up the wick. This is due to capillary action.

Definition:

Capillarity is the rise or fall of a liquid in a narrow tube.

Capillary rise (elevation):

This is the rising of a liquid in a narrow tube (capillary tube).

Capillary rise occurs when adhesion forces between liquid molecules and glass tube molecules are greater than the cohesion forces between liquid molecules themselves. The liquid is attracted more to the surfaces of the tube thus causing it to rise.

- ✦ When a narrow tube (capillary tube) is dipped into a container containing water, water rises up in the tube.

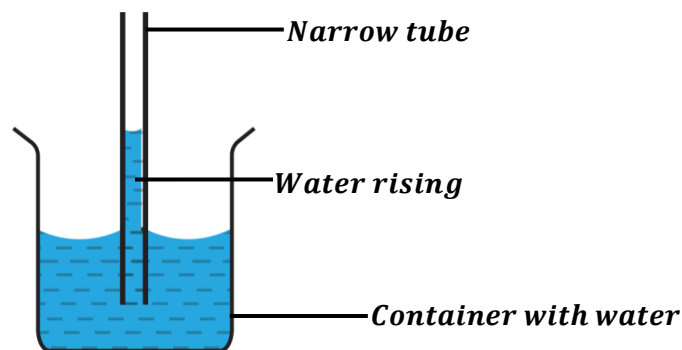

- ✦ When two or more narrow tubes (capillary tubes) are dipped into a container containing water, the rise of water depends on the diameter of the tube i.e. the rise of water is higher or greatest in a small tube and lowest or least in the large tube.

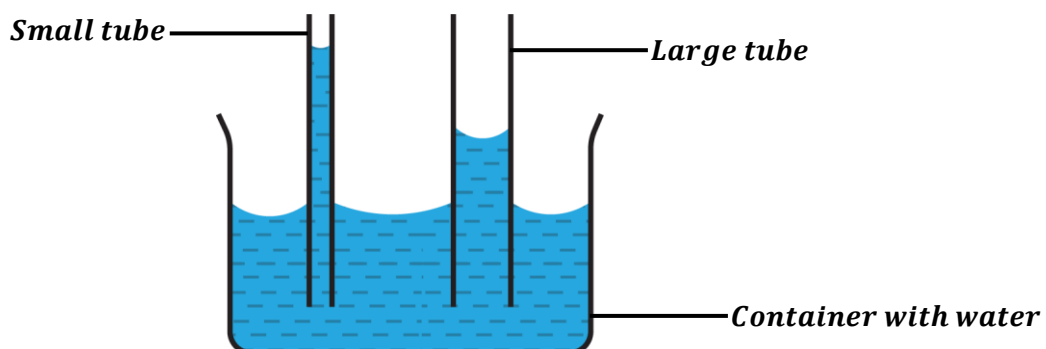

Question: Explain why water climbs up a piece of paper that has been dipped into a glass of water.

This is because the adhesive forces between water molecules and glass molecules are strong enough to pull the water molecules from glass and move them up the paper.

Capillary fall (depression):

This is the falling of a liquid in a narrow tube (capillary tube).

Capillary fall occurs when cohesion forces between liquid molecules themselves are greater than the adhesion forces between liquid molecules and glass tube molecules. The liquid is attached or attracted less to the surfaces of the tube thus causing it to fall.

- ✧ When a narrow tube (capillary tube) is dipped into a container containing mercury, mercury level falls in the tube.

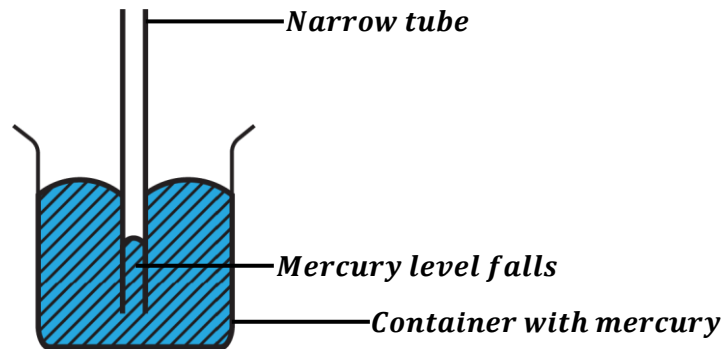

- ✧ When two or more narrow tubes (capillary tubes) are dipped into a container containing mercury, the fall of mercury depends on the diameter of the tube i.e. the fall of mercury is higher or greatest in a small tube and lowest or least in the large tube.

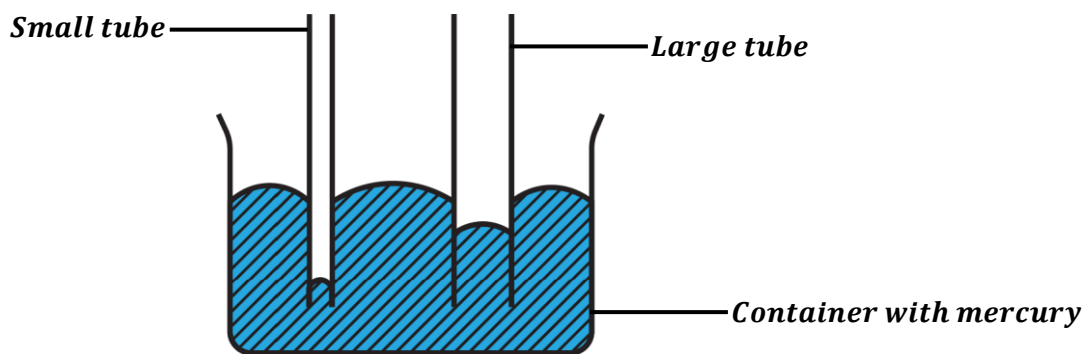
NOTE:

- Capillarity is disadvantageous and dangerous in construction of buildings because it causes water to rise through the walls of the building from the ground. This can be prevented by covering the damp proof course of a building with a non-porous material (water proof) e.g. polythene.

Question 1: Explain why a non-porous material is often put on the damp proof course of a building during construction.

The non-porous material prevents the rise of water through the walls of a building from the ground. Therefore, if it is not put on the damp proof course of a building, water rises through the walls by capillary action thus weakening the walls of the building.

Question 2: Explain why mercury level falls when a capillary tube is dipped into a beaker containing mercury.

This is because the cohesion forces between mercury molecules themselves are greater than the adhesion forces between mercury molecules and capillary tube molecules. The liquid is attached or attracted less to the surfaces of the tube thus causing it to fall.

APPLICATIONS OF CAPILLARITY:

- Rising of paraffin in the wicks of stoves or lamps.
- Movement of water and minerals from the roots to the other parts of the plant.
- Absorption of water by a towel through its pores.
- Absorption of liquids by a blotting paper or toilet paper.

Revision questions:

1. Explain how capillary rise occurs in a narrow tube.
2. Explain the following observations.
 - i) Water wets clean glass surfaces but not waxed glass surfaces.
 - ii) Water rises up in a narrow tube but mercury which is also a liquid falls in a narrow tube.
3. Explain why the lower part of the walls (near the floor) appear damp and begin to peel off a few years after construction.

SURFACE TENSION:

Several insects are able to walk on water surfaces; and when water drops slowly, it stretches and forms droplets. This is because at the surface of a water, there exists a force which makes the water surface to behave like a stretched elastic skin.

**Definition:**

Surface tension is force acting on the surface of the liquid that makes the liquid surface to behave like a stretched elastic skin.

OR

Surface tension is the tangential force acting normally per unit length of an imaginary line drawn on the surface of the liquid.

Therefore;

$$\text{Surface tension} = \frac{\text{Force}}{\text{Length}}$$

The SI unit of surface tension is Newton per metre (Nm^{-1}).

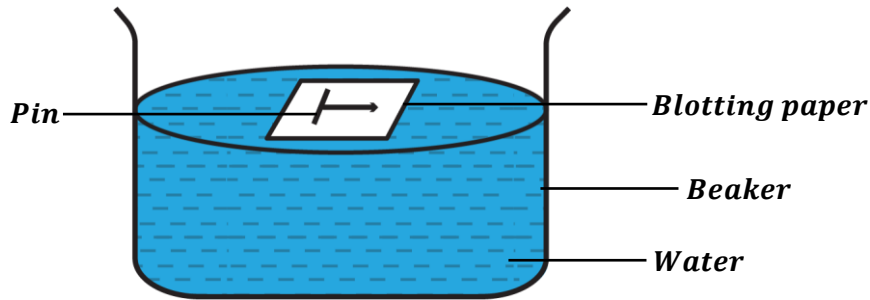
An experiment to show the existence of surface tension

Procedures:

- A beaker is filled with clean water.
- A blotting paper is placed carefully on the surface of water.
- A pin is gently placed on the blotting paper.

Observation:

- It is observed that after sometime, the blotting paper absorbs water and sinks to the bottom but the pin remains floating on the water surface.

Explanation:

- The pin remains floating on the water surface because the surface of water behaves like a stretched elastic skin.
- This demonstrates surface tension.

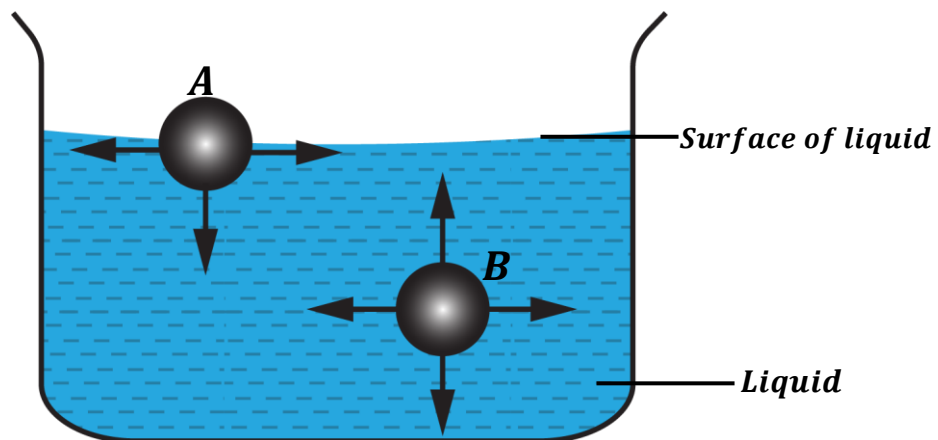
Explanation of surface tension using the kinetic theory of matter

- A molecule B inside the liquid is surrounded by equal number of molecules on all sides. Therefore, the intermolecular forces between it and the surrounding molecules is the same in all directions. Thus, the resultant force on molecule B is zero.
- A molecule A on the surface of the liquid is only surrounded by molecules below it. Therefore, the intermolecular forces between it and the surrounding molecules only acts downwards. Thus, the resultant force on molecule A acts downwards.
- This downward resultant force on molecule A pulls the surface of the liquid downwards thus the surface behaves like a stretched elastic skin.

Factors that affect surface tension:**a) Temperature:**

Increase in temperature reduces surface tension. This is because an increase in temperature weakens (breaks down) the intermolecular forces between the liquid molecules.

b) Impurities:

Adding impurities like soap solution and detergents (e.g. Omo, Nomi, Vim, etc.) weakens the intermolecular forces between the liquid molecules thus reducing surface tension on the liquid surface.

Question 1: State two ways of reducing surface tension of a liquid.

- *By adding soap solution and detergents like Omo, Nomi and Vim into the liquid.*
- *By increasing the temperature of the liquid i.e. heating it.*

Question 2: A razor blade on a filter paper is gently placed on the surface of water in a container.

- i) Explain what happens after some time.
After sometime, the filter paper will absorb water and sink to the bottom of the container but razor blade will remain floating on the surface of water. The razor blade remains floating because the surface of water is behaving as a stretched elastic skin.
- ii) Explain what happens when some soap solution is carefully added to the water.
The razor blade will also sink if soap solution is added to the water. This is because adding soap weakens the intermolecular forces between the water molecules thus reducing the surface tension of the water.

Question 3: Explain why it is advisable to wash clothes using warm water.

This is because warming water reduces its surface tension. This helps the clothes to absorb water and get wetted easily thus removing the dirt thoroughly well.

Question 4: Explain why soap is used in washing clothes.

This is because soap reduces surface tension of water hence causing water to penetrate the clothes easily. This helps to remove the dirt from the clothes easily.

Question 5: During a rainy season we normally use umbrellas, tents and rain coats.

- a) Explain why umbrellas do not leak when it rains yet they are porous.
They do not leak because surface tension of water prevents it from penetrating the fabric of the umbrella.
- b) Explain why the inside of umbrellas in (a) above turn wet when the inside is touched.
Touching the inside of the umbrella increases the temperature of water on the outside part of the umbrella. This reduces the surface tension of water thus penetrating the fabric of the umbrella hence wetting the inside of the umbrella.

Application of surface tension (Instances to show existence of surface tension):

- Small insects can walk on the surface of water without sinking.
- Dirt get removed easily when soap and detergents are added to water when washing clothes.
- Umbrellas, tents and rain coats are able to keep water off due to surface tension.
- A pin or needle or razor blade can float on water when gently put on it surface even though they are denser than water.
- Water drops from a tap form spherical shape.
- When water is dropping slowly, a drop of water may remain attached from the tap for some time before falling.

NOTE:

- ✂ Surface tension may also be demonstrated at home by using soap.

An experiment to demonstrate surface tension by using soap

- Make a ring of thin wire.
- Tie a thread loosely across the ring of thin wire as shown below.



- Dip the ring inside a soap solution so that the ring is filled the soap film and pull it out.
- Break the soap film on one side of the thread.
- It is observed that the thread pulls tight and forms a perfect curve as shown below.

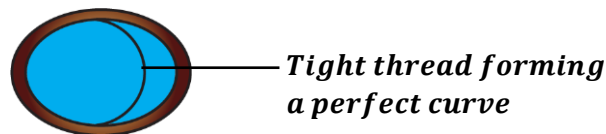

- This shows that the thread is being pulled by a certain force on surface of the soap solution. This force is what we call surface tension.

Revision questions:

1. Explain why it is not advisable to touch tent fabric material when it is raining.
2. Explain why it is not easy to wash clothes without soap.

SIZE OR THICKNESS OF AN OIL MOLECULE

Matter is made of small or tiny particles called molecules. These particles are too small to see with our human eyes. So how small are these molecules?

When oil is dropped on the surface of water, it spreads out until it forms an oil film which is just one molecule thick i.e. (*thickness of oil film = size of one oil molecule*).

Therefore, we can estimate the size of an oil molecule by finding the thickness of an oil film formed on water through the oil drop experiment.

An experiment to estimate the size or thickness of an oil molecule

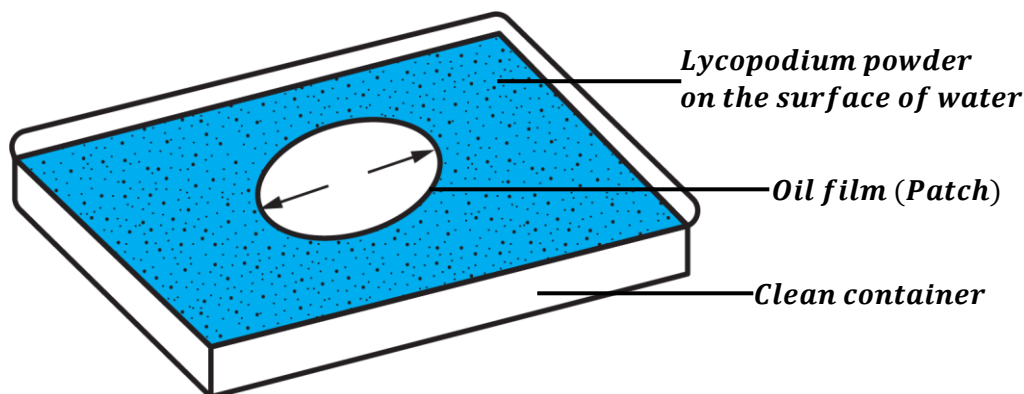

- A clean container is filled with clean water.
- Lycopodium powder is sprinkled on the surface of water.
- A small drop of oil of known volume, V is placed on the surface of water.
- The oil drop spreads and forms a circular oil film (patch) on the surface of water.
- The diameter, d of the circular oil film on the surface of water is measured and recorded.
- The area, A of the circular oil film is determined from;

$$A = \pi r^2 \text{ or } A = \frac{\pi d^2}{4}$$

- The thickness or size of oil molecule is then determined from;

$$t = \frac{V}{A}$$

Assumptions made in the oil drop experiment:

The following diagrams may be used to understand the assumptions.



- The oil drop is spherical.
- The oil film (patch) is cylindrical.
- The oil film is one molecule thick (monomolecular). i.e. thickness of an oil film is equal to size or diameter of one oil molecule.
- The spaces between oil molecules in the oil film are negligible.
- The volume of oil drop is equal to volume of oil film (oil patch).

Uses of lycopodium powder in the oil drop experiment:

- It helps us to see the oil film clearly.
- It makes the oil film stable for easy measurement of the diameter.

EXPLANATIONS BEHIND THE OIL DROP EXPERIMENT:

Volume of the oil drop = Volume of the oil film

Volume of sphere = Volume of a cylinder

$$\frac{4}{3}\pi r_o^3 = \pi r_f^2 t \quad \text{Where height, } h = t \text{ and } r = \frac{d}{2}$$

r_o – Radius of oil drop

r_f – Radius of oil film or oil patch

NOTE:

- ✂ Sometimes, the oil drop may be determined or formed by mixing oil with another liquid to form a solution. Then, the solution is dropped on the water surface.

Therefore, we have to find the volume of the oil drop (without the other liquid) dropped on the surface of water.

$$\text{Volume of oil drop} = \left(\frac{\text{Volume of oil dissolved}}{\text{Total volume of solution}} \right) \times \text{Volume of solution dropped}$$

- ✂ Number of oil molecules in an oil film can be obtained from;

$$\text{Number of oil molecules} = \frac{\text{Volume of oil drop}}{\text{Volume of one oil molecule}}$$

NOTE: Diameter of an oil molecule is equal to thickness (size) of oil mol

Examples:

1. In an oil drop experiment, the diameter of the oil film is 5cm and the volume of oil drop used is 0.005cm^3 . Find the thickness of an oil film.

$$d = 5\text{cm}, \quad V = 0.005\text{cm}^3$$

$$r = \frac{d}{2} = \frac{5}{2} = 2.5\text{cm}$$

Area of oil film:

$$A = \pi r^2$$

$$A = \frac{22}{7} \times 2.5^2 = 1.96 \times 10^1 \text{cm}^2$$

Thickness of oil film:

$$t = \frac{\text{Volume of oil drop}}{\text{Area of oil film}}$$

$$t = \frac{V}{A}$$

$$t = \frac{0.005}{1.96 \times 10^1}$$

$$t = 2.55 \times 10^{-4} \text{cm}$$

2. In an oil drop experiment, an oil patch of radius 10cm is formed by $2.5 \times 10^{-3} \text{cm}^3$ of oil drop.
- a) Calculate the approximate size of an oil molecule.

$$r = 10\text{cm}, V = 2.5 \times 10^{-3} \text{cm}^3$$

Volume of oil drop:
 $V = 2.5 \times 10^{-3} \text{cm}^3$

Area of oil film:
 $A = \pi r^2$
 $A = \frac{22}{7} \times 10^2 = 3.14 \times 10^2 \text{cm}^2$

Thickness of oil molecule:
 $t = \frac{\text{Volume of oil drop}}{\text{Area of oil film}}$
 $t = \frac{V}{A}$
 $t = \frac{2.5 \times 10^{-3}}{3.14 \times 10^2}$
 $t = 7.96 \times 10^{-6} \text{cm}$

- b) State any two assumptions used.
 → *Volume of oil drop is equal to volume of oil film.*
 → *Oil film is cylindrical.*

3. In an oil drop experiment, the area of the oil film formed on the water surface is 0.655cm^2 and the volume of oil drop used is 0.0015cm^3 . Find the thickness of oil molecule.

$$A = 0.655 \text{cm}^2, \quad V = 0.0015 \text{cm}^3$$

Thickness of oil film:
 $t = \frac{\text{Volume of oil drop}}{\text{Area of oil film}}$

$$t = \frac{V}{A}$$

$$t = \frac{0.0015}{0.655}$$

$$t = 2.29 \times 10^{-3} \text{cm}$$

4. In an experiment to estimate the thickness of an oil molecule, the radius of spherical oil drop is 0.25mm and the radius of the circular patch of oil formed on the water surface is 6.5cm. Calculate the thickness of an oil molecule.

$$\text{radius of oil drop} = 0.25\text{mm} = \frac{0.25}{10} \text{cm}$$

$$r = 2.5 \times 10^{-2} \text{cm}$$

Volume of oil drop:
 $V = \frac{4}{3} \pi r^3$
 $V = \frac{4}{3} \times \left(\frac{22}{7}\right) \times (2.5 \times 10^{-2})^3$
 $V = 6.55 \times 10^{-5} \text{cm}^3$

$$\text{radius of oil patch} = 6.5\text{cm}$$

Area of oil patch:
 $A = \pi r^2$
 $A = \frac{22}{7} \times 6.5^2 = 1.33 \times 10^2 \text{cm}^2$

Thickness of oil film:
 $t = \frac{\text{Volume of oil drop}}{\text{Area of oil film}}$
 $t = \frac{V}{A}$
 $t = \frac{6.55 \times 10^{-5}}{1.33 \times 10^2}$
 $t = 4.92 \times 10^{-7} \text{cm}$

5. An oil drop of volume 10^{-3}cm^3 forms a film on the water surface. The area of the film formed is 0.785cm^2 . If the oil film is one molecule thick, estimate the thickness of the film.

$$A = 0.785 \text{cm}^2, \quad V = 10^{-3} \text{cm}^3$$

Thickness of oil film:

$$t = \frac{\text{Volume of oil drop}}{\text{Area of oil film}}$$

$$t = \frac{V}{A}$$

$$t = \frac{10^{-3}}{0.785}$$

$$t = 1.27 \times 10^{-3} \text{ cm}$$

6. A solution was made by dissolving 1cm^3 of cooking oil in 199cm^3 of methanol. When 0.004cm^3 of the solution is dropped on the surface of water, an oil film of diameter 12cm is obtained. Calculate;

- i) the volume of cooking oil in the drop.

$$\text{Volume of oil drop} = \left(\frac{\text{Volume of oil dissolved}}{\text{Total volume of solution}} \right) \times \text{Volume of solution dropped}$$

$$\text{Volume of oil drop} = \left(\frac{1}{1 + 199} \right) \times 0.004$$

$$\text{Volume of oil drop} = 0.00002 \text{cm}^3$$

- ii) the thickness of the cooking oil molecule.

$$r = \frac{d}{2} = \frac{12}{2} = 6 \text{cm}$$

Area of oil film:

$$A = \pi r^2$$

$$A = \frac{22}{7} \times 6^2 = 1.13 \times 10^2 \text{cm}^2$$

Thickness of oil film:

$$t = \frac{\text{Volume of oil drop}}{\text{Area of oil film}}$$

$$t = \frac{V}{A}$$

$$t = \frac{0.00002}{1.13 \times 10^2}$$

$$t = 1.77 \times 10^{-7} \text{ cm}$$

- iii) the number of molecules in the oil film.

Volume of an oil molecule

Recall: Diameter of oil molecule is equal to thickness of oil molecule.

$$r = \frac{d}{2} = \frac{t}{2} = \frac{1.77 \times 10^{-7}}{2} = 8.85 \times 10^{-8} \text{cm}$$

$$V = \frac{4}{3} \pi r^3$$

$$V = \frac{4}{3} \times \left(\frac{22}{7} \right) \times (8.85 \times 10^{-8})^3$$

$$V = 2.90 \times 10^{-21} \text{cm}^3$$

Number of oil molecules:

$$N = \frac{\text{Volume of oil drop}}{\text{Volume of one oil molecule}}$$

$$N = \frac{0.00002}{2.90 \times 10^{-21}}$$

$$N = 6.897 \times 10^{15} \text{ molecules}$$

7. 1cm^3 of oleic acid was dissolved in 999cm^3 of alcohol to form 1000cm^3 of solution. 1cm^3 drop of the solution was put on the water surface. The drop spread to form a patch of diameter 28cm . Calculate;

a) Volume of oleic acid in 1cm^3 drop of the solution.

$$\text{Volume of acid drop} = \left(\frac{\text{Volume of acid dissolved}}{\text{Total volume of solution}} \right) \times \text{Volume of solution dropped}$$

$$\text{Volume of acid drop} = \left(\frac{1}{1000} \right) \times 1$$

$$\text{Volume of acid drop} = 0.001\text{cm}^3$$

b) The size of the oleic acid molecule.

$$r = \frac{d}{2} = \frac{28}{2} = 14\text{cm}$$

Area of acid film:

$$A = \pi r^2$$

$$A = \frac{22}{7} \times 14^2 = 616\text{cm}^2$$

Thickness of acid film:

$$t = \frac{\text{Volume of oil drop}}{\text{Area of oil film}}$$

$$t = \frac{V}{A}$$

$$t = \frac{0.001}{616}$$

$$t = 1.62 \times 10^{-6} \text{ cm}$$

c) Volume of oleic acid molecule.

Recall: Diameter of acid molecule is equal to thickness of acid molecule.

$$r = \frac{d}{2} = \frac{t}{2} = \frac{1.62 \times 10^{-6}}{2} = 8.1 \times 10^{-7} \text{ cm}$$

$$V = \frac{4}{3} \pi r^3$$

$$V = \frac{4}{3} \times \left(\frac{22}{7} \right) \times (8.1 \times 10^{-7})^3$$

$$V = 2.23 \times 10^{-18} \text{ cm}^3$$

d) Number of oleic acid molecules in the patch.

$$N = \frac{\text{Volume of acid drop}}{\text{Volume of acid molecule}}$$

$$N = \frac{0.001}{2.23 \times 10^{-18}}$$

$$N = 4.48 \times 10^{14} \text{ molecules}$$

8. 1cm^3 of olive oil was added to 99cm^3 of ethanol to form a solution. 2cm^3 drop of the solution was put on the water surface. The drop spread to form a film of radius 12cm . Calculate;

a) Volume of olive oil in 2cm^3 drop of the solution.

$$\text{Volume of oil drop} = \left(\frac{\text{Volume of oil dissolved}}{\text{Total volume of solution}} \right) \times \text{Volume of solution dropped}$$

$$\text{Volume of oil drop} = \left(\frac{1}{1+99} \right) \times 2$$

$$\text{Volume of oil drop} = 0.02\text{cm}^3$$

b) The thickness of the oil film.

$$r = 12\text{cm}$$

Area of oil film:

$$A = \pi r^2$$

$$A = \frac{22}{7} \times 12^2 = 4.53 \times 10^2 \text{cm}^2$$

Thickness of oil film:

$$t = \frac{\text{Volume of oil drop}}{\text{Area of oil film}}$$

$$t = \frac{V}{A}$$

$$t = \frac{0.02}{4.53 \times 10^2}$$

$$t = 4.42 \times 10^{-5} \text{cm}$$

EXERCISE:

- In an oil drop experiment, the radius of the oil film is 10cm and the volume oil drop used is $1.1 \times 10^{-5} \text{cm}^3$. Estimate the thickness of an oil molecule.
- If $1.8 \times 10^{-4} \text{cm}^3$ of oil spreads to form a patch of area 150cm^2 , calculate the size of an oil molecule.
- In an experiment to estimate the size of a molecule of olive oil, 0.12mm^3 of the oil solution was dropped on a clean water surface in a trough. The oil spreads to form a circular patch of an area $1.0 \times 10^4 \text{cm}^2$. Estimate the size of a molecule of olive oil.
- 1cm^3 of oil was added to 299cm^3 of ether to form a solution. 2cm^3 drop of the solution was put on the water surface with sprinkled lycopodium powder. The drop spreads to form a film of diameter 14cm. Calculate;
 - Thickness of the oil molecule.
 - Number of oil molecules in the film.
 - State any three assumptions made.
 - Why was lycopodium powder used?
- An oil drop of volume $1.0 \times 10^{-9} \text{m}^3$ spreads on a water surface to form an oil patch of area $5 \times 10^{-2} \text{m}^2$. If the patch is one molecule thick, find the approximate number of molecules in the drop.
- In an oil drop experiment to determine the thickness of an oil molecule, the following were done;
 - 1cm^3 of oil was dissolved in 99cm^3 of ethanol to form 200cm^3 of solution.
 - 0.4cm^3 of the dilute solution was dropped onto the surface of water.
 - The diameter of the film formed was found to be 7cm.
 Calculate the size of the oil molecule
- A solution was made by dissolving 1cm^3 of cooking oil in 1999cm^3 of methanol. When 0.005cm^3 of the solution is dropped on the surface of water, an oil film of diameter 14cm is obtained. Calculate;
 - the volume of cooking oil in the drop.
 - The thickness of the oil molecule.
 - The number of molecules in the oil film.
- In an oil drop experiment, the area of the oil patch formed on the water surface is 0.700cm^2 and the volume of oil drop used is 0.0016cm^3 . Find the diameter of oil molecule.

MACHINES

A machine is a device used to simplify work.

When using a machine, a force is applied at one point to overcome another force at another point.

A machine is used to;

- Convert energy from one form to another.
- Amplify the force used.

PRINCIPLE OF MACHINES:

It states that a small force applied (effort) moves a large distance to produce a bigger force that moves a load through a small distance.

TERMS USED IN MACHINES

Effort (E):

This is the force applied at one point of a machine to overcome the load.

The SI unit is the Newton (N).

Load (L):

This is the force which is overcome by the effort.

The SI unit is the Newton (N).

Mechanical Advantage (M.A):

This is the ratio of load to effort.

$$\text{Mechanical Advantage} = \frac{\text{Load}}{\text{Effort}}$$
$$M.A = \frac{L}{E}$$

Mechanical Advantage doesn't have units.

Velocity Ratio (V.R):

This is the ratio of distance moved by the effort to distance moved by the load in the same time.

$$\text{Velocity Ratio} = \frac{\text{Distance moved by Effort}}{\text{Distance moved by the load}}$$
$$V.R = \frac{D_E}{D_L}$$

Velocity Ratio doesn't have units.

Work input (W.I):

This is the work done by the effort to overcome the load.

OR

This is the product of effort and the distance moved by the effort.

$$\text{Work input} = \text{Effort} \times \text{Distance moved by the Effort}$$
$$W.I = E \times D_E$$

The SI unit of work input is a joule (J).

Work output (W.O):

This is the work done by the machine to overcome the load.

OR

This is the product of load and the distance moved by the load.

$$\text{Work input} = \text{Load} \times \text{Distance moved by the Load}$$

$$W.O = L \times D_L$$

The SI unit of work output is a joule (J).

Work output is also referred to as work done on the load.

Energy wasted:

This is the difference between Work input and Work output.

$$\text{Energy wasted} = \text{Work input} - \text{Work output}$$

Efficiency (η):

This is the ratio of work output to work input of a machine expressed as a percentage.

$$\text{Efficiency } (\eta) = \frac{\text{Work output}}{\text{Work input}} \times 100\%$$

$$\text{Efficiency } (\eta) = \frac{L \times D_L}{E \times D_E} \times 100\%$$

$$\text{Efficiency } (\eta) = \frac{L}{E} \times \frac{D_L}{D_E} \times 100\%$$

$$\text{But } M.A = \frac{L}{E} \text{ and } \frac{1}{V.R} = \frac{D_L}{D_E}$$

$$\text{Efficiency } (\eta) = M.A \times \frac{1}{V.R} \times 100\%$$

$$\text{Efficiency } (\eta) = \frac{M.A}{V.R} \times 100\%$$

NOTE:

In practice, the efficiency of a machine is always less than 100%.

Reasons why efficiency of a machine is always less than 100%:

- Some energy is wasted or lost in overcoming friction between the movable parts of a machine.
- Some energy is wasted or lost in lifting useless loads e.g. strings in pulleys.

How to increase the efficiency of a machine:

- By lubricating the movable parts of the machine i.e. oiling and greasing.
- By using light materials for useless loads.

Examples:

1. An effort of 200N moves a distance of 1.5m to lift a load of 480N through 1m. Calculate;
 - (i) Mechanical Advantage.
 - (ii) Velocity ratio.
 - (iii) Work output.
 - (iv) Work input.
 - (v) Efficiency.

$E = 200N, \quad D_E = 1.5m, \quad L = 480N, \quad D_L = 1m$		
(i) Mechanical advantage $M.A = \frac{L}{E}$ $M.A = \frac{480}{200}$ $M.A = 2.4$	(ii) Velocity ratio $V.R = \frac{D_E}{D_L}$ $V.R = \frac{1.5}{1}$ $V.R = 1.5$	(iii) Work output $W.O = L \times D_L$ $W.O = 480 \times 1$ $W.O = 480J$
(iv) Work input $W.I = E \times D_E$ $W.I = 200 \times 1.5$ $W.I = 300J$	(v) Efficiency $\eta = \frac{M.A}{V.R} \times 100\%$ $\eta = \frac{2.4}{1.5} \times 100\%$ $\eta = 1.6 \times 100\%$ $\eta = 160\%$	

2. If a lever is used to overcome a load of 50N by applying an effort of 10N. Find;

- (i) Mechanical advantage of the lever system.
 (ii) Efficiency of the system if the velocity ratio is 6.

$$L = 50N, \quad E = 10N, \quad V.R = 6$$

(i) Mechanical advantage

$$M.A = \frac{L}{E}$$

$$M.A = \frac{50}{10}$$

$$M.A = 5$$

(ii) Efficiency

$$\eta = \frac{M.A}{V.R} \times 100\%$$

$$\eta = \frac{5}{6} \times 100\%$$

$$\eta = 83.3\%$$

3. In a machine, 50N are used to overcome a load of 20kg. If the 20kg load moves a distance of 5cm whenever the 50N moves a distance of 25cm.

Calculate;

- (i) Mechanical advantage. (ii) Velocity ratio (iii) Efficiency.

$$E = 50N, \quad D_E = 5cm = \frac{25}{100} = 0.25m,$$

$$L = mg = 20 \times 10 = 200N, \quad D_L = \frac{5}{100} = 0.05m$$

(i) Mechanical advantage

$$M.A = \frac{L}{E}$$

$$M.A = \frac{200}{50}$$

$$M.A = 4$$

(ii) Velocity ratio

$$V.R = \frac{D_E}{D_L}$$

$$V.R = \frac{0.25}{0.05}$$

$$V.R = 5$$

(iii) Efficiency

$$\eta = \frac{M.A}{V.R} \times 100\%$$

$$\eta = \frac{4}{5} \times 100\%$$

$$\eta = 0.8 \times 100\%$$

$$\eta = 80\%$$

4. An effort of 100N is used to raise a load of 200N. If the effort moves through a distance of 4m, calculate;
- Distance moved by the load if the velocity ratio is 5.
 - Energy wasted by the machine.
 - Efficiency of the machine.

$$E = 100N, \quad D_E = 4m, \quad L = 200N, \quad D_L = ?, \quad V.R = 5$$

- (i) Distance moved by load

$$V.R = \frac{D_E}{D_L}$$

$$5 = \frac{4}{D_L}$$

$$D_L = \frac{4}{5}$$

$$D_L = 0.8m$$

- (ii) Energy wasted.

Work input:

$$W.I = E \times D_E$$

$$W.I = 100 \times 4$$

$$W.I = 400J$$

Work output:

$$W.O = L \times D_L$$

$$W.O = 200 \times 0.8$$

$$W.O = 160J$$

$$Energy\ wasted = W.O - W.I$$

$$Energy\ wasted = 400 - 160$$

$$Energy\ wasted = 240J$$

- (iii) Efficiency

$$\eta = \frac{W.O}{W.I} \times 100\%$$

$$\eta = \frac{160}{400} \times 100\%$$

$$\eta = 0.4 \times 100\%$$

$$\eta = 40\%$$

5. In a machine which is 75% efficient, an effort of 300N is used to lift a load of 900N. If the load is moved through a distance of 2m, find the;
- Mechanical advantage.
 - Velocity ratio.
 - Distance moved by the effort.

$$E = 300N, \quad D_L = 2m, \quad L = 900N, \quad D_E = ?, \quad \eta = 75\%$$

- (i) Mechanical advantage

$$M.A = \frac{L}{E}$$

$$M.A = \frac{900}{300}$$

$$M.A = 3$$

- (ii) Velocity ratio

$$\eta = \frac{M.A}{V.R} \times 100\%$$

$$75\% = \frac{3}{V.R} \times 100\%$$

$$75\%V.R = 300\%$$

$$V.R = \frac{300\%}{75\%}$$

$$V.R = \frac{300\%}{75\%}$$

$$V.R = 4$$

- (iii) Distance moved by effort

$$V.R = \frac{D_E}{D_L}$$

$$4 = \frac{D_E}{2}$$

$$D_E = 4 \times 2$$

$$D_E = 8m$$

EXERCISE:

1. An effort of 100N moves through 12cm while moving a Load of 400N through 2cm. Find;
 - i) the mechanical advantage.
 - ii) the velocity ratio
 - iii) the efficiency of the machine.
2. A water pump raises 2000kg of water through a vertical height of 22m. If the efficiency of the water pump is 80%, calculate the work input.
3. A simple machine raises a load of 60N through a distance of 2m by an effort of 20N which moves through a distance of 8m. Calculate the machine's efficiency.
4. A load of 100N is raised through 6m when an effort of 40N moves through a distance of 24m. Calculate the;
 - i) mechanical advantage.
 - ii) velocity ratio.
 - iii) energy wasted by the machine.
 - iv) efficiency of the machine.
5. A simple machine raises a load of 300kg through 0.5m when an effort of 150N is applied through a distance of 12.5m. Calculate the;
 - i) work input into machine.
 - ii) work output by the machine.
 - iii) efficiency of the machine.

Examples of simple machines include;

- Levers
- Pulleys
- Inclined planes
- Hydraulic machines
- Wheel and axle
- Gears
- Screws
- wedges

LEVERS

A lever is a rigid body is free to turn about a fixed point.

The fixed point at which the lever turns is called the **pivot** or **fulcrum**.

Classes of levers:

There are three classes of levers namely;

- First class lever.
- Second class lever.
- Third class lever.

FIRST CLASS LEVERS

This is the type of lever where the pivot is between the load and the effort (LPE).

Examples include;

- Crow bar
- Beam balance
- Pair of scissors
- Pair of pliers
- See saw
- Claw hammer
- Shears
- Secateurs

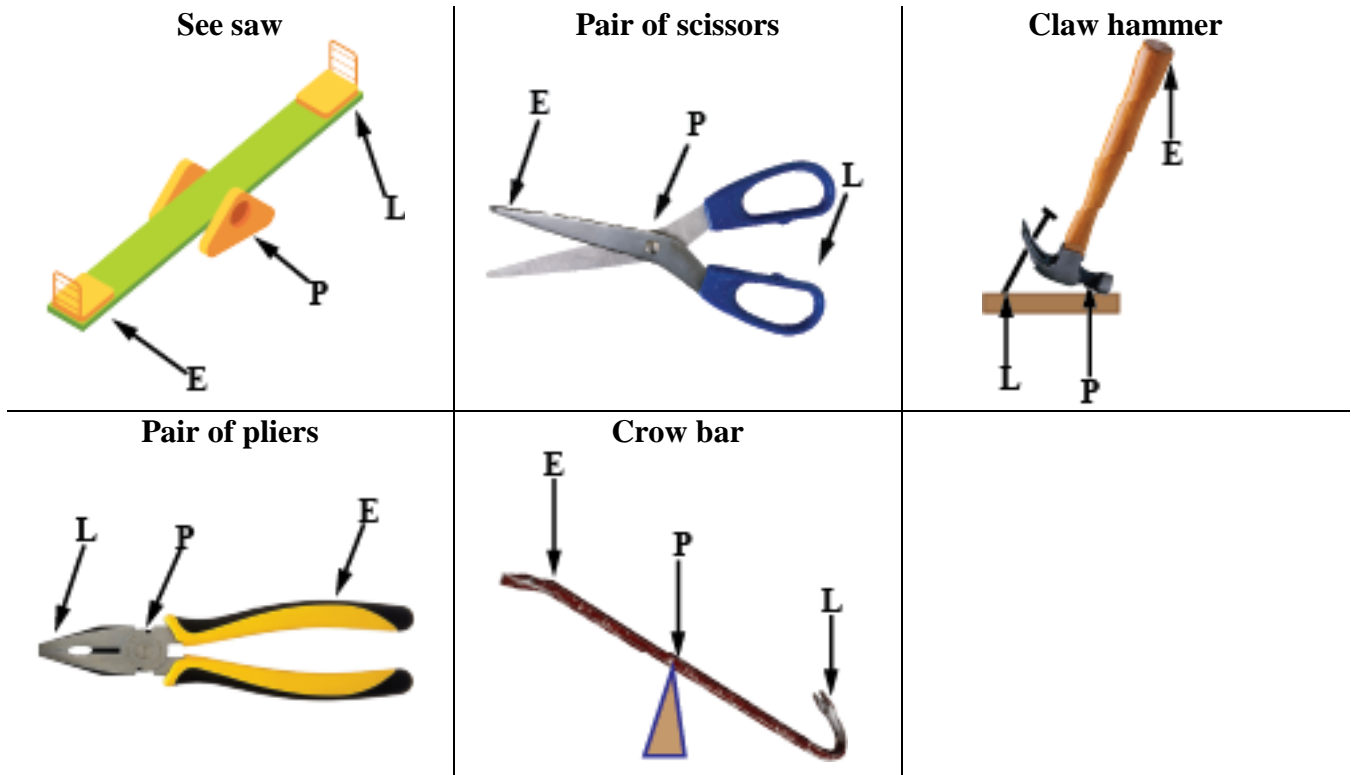

SECOND CLASS LEVERS

This is the type of lever where the load is between the pivot and the effort (PLE).

Examples include;

- Wheel barrow
- Nut cracker
- Bottle opener
- Office punching machine

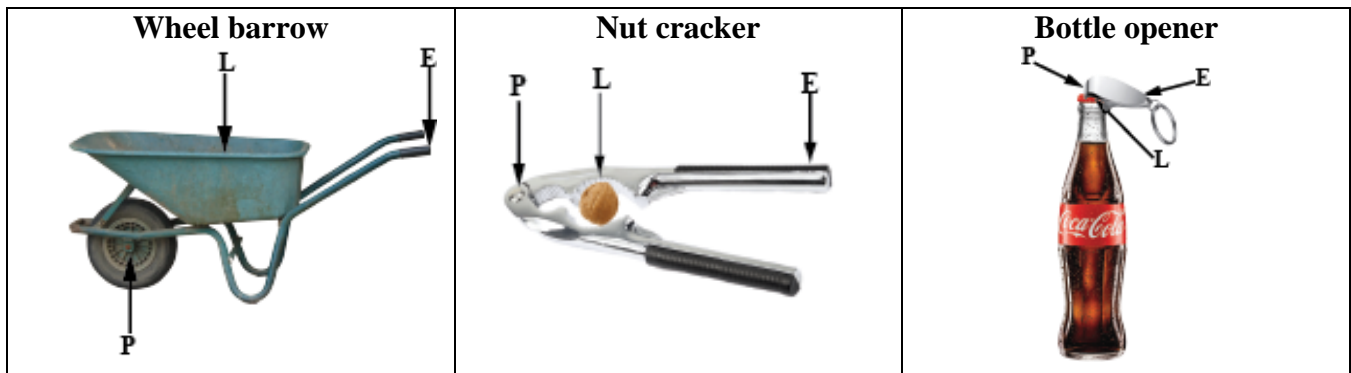

THIRD CLASS LEVERS

This is the type of lever where the effort is between the load and the pivot (LEP).

Examples include;

- Spade
- Pair of tongs
- Tweezers
- Broom
- Fishing rod
- Stapling machine

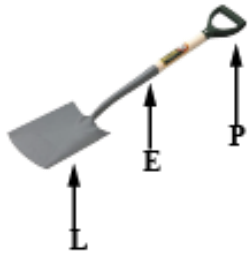
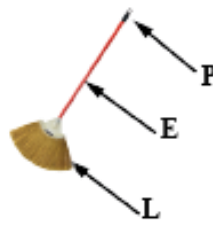
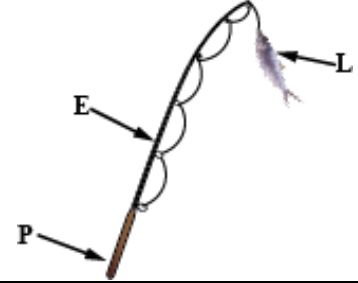
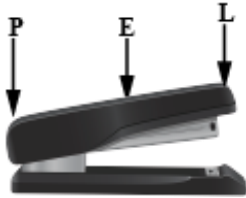
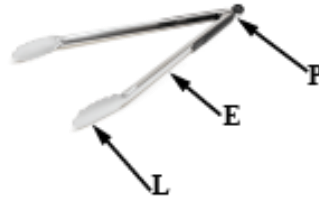
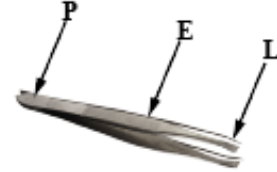
Spade

Broom

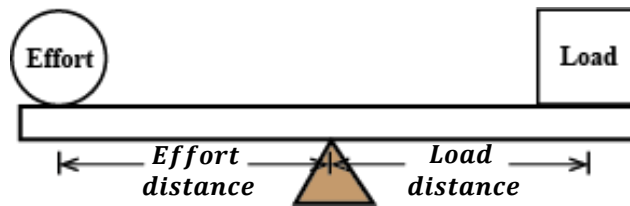
Fishing rod

Stapling machine

Forceps

Tweezers

NOTE:

Consider the diagram below.



- The operation of a lever depends on the principle of moments.
- The efficiency of a lever can be increased by the effort distance (distance of the effort from the turning point).

PULLEYS

A pulley is a wheel with a grooved rim on which a rope passes.

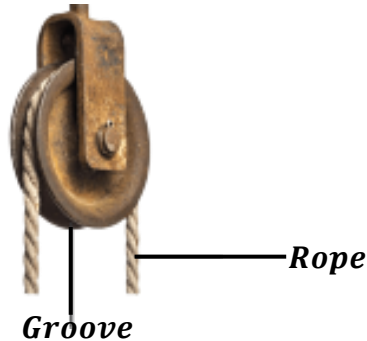

Types of pulley systems:

There are three types of pulleys namely;

- Single fixed pulley.
- Single movable pulley.
- Block and tackle pulley.

SINGLE FIXED PULLEY:

This is a type of pulley system in which the pulley is fixed on the rigid support.

In a single fixed pulley, the load is tied to one end and the effort applied to another end of the rope.

As the rope is pulled downwards, the load is raised upwards.

Therefore, a single fixed pulley eases work by changing the direction of the application of the effort.

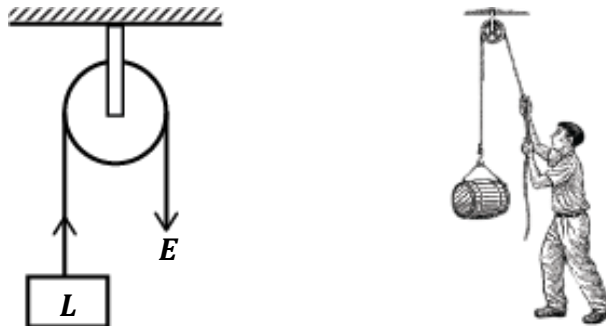

Assuming, there is no friction in the groove and the rope is weightless;

At equilibrium;

$$\text{Upward forces} = \text{Downward forces}$$

$$L = E$$

Therefore, $M.A = \frac{L}{E} = \frac{E}{E} = 1$

In real practice, the effort is always greater than the load because it is used to overcome friction in the groove and also used to lift the weight of the groove. Therefore, mechanical advantage is always less than 1.

However, the distance moved by the effort is always equal to the distance moved by the load i.e.

$$D_E = D_L$$

Therefore, $V.R = \frac{D_E}{D_L} = \frac{D_L}{D_L} = 1$

SINGLE MOVABLE PULLEY:

This is the type of pulley system in which the pulley moves along with the rope.

One end of the rope is fixed to a rigid support and the effort is applied on the other end.

The advantage of this pulley system is that less effort is required to lift the load thus raising it easily.

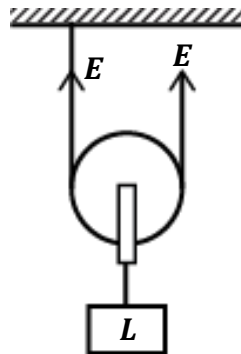

Assuming, there is no friction in the groove and the rope is weightless;

At equilibrium;

Upward forces = Downward forces

$$L = E + E$$

$$L = 2E$$

Therefore, $M.A = \frac{L}{E} = \frac{2E}{E} = 2$

In real practice, the effort is always greater than the load because it is used to overcome friction in the groove and also used to lift the weight of the groove. Therefore, mechanical advantage is always less than 2.

However, the distance moved by the effort is always twice the distance moved by the load i.e.

$$D_E = 2D_L$$

Therefore, $V.R = \frac{D_E}{D_L} = \frac{2D_L}{D_L} = 2$

BLOCK AND TACKLE PULLEY SYSTEM:

This is the type of pulley system where two or more pulleys are combined to form a machine with high velocity ratio and high mechanical advantage.

It consists of two blocks namely;

- Fixed block.
- Movable block.

These blocks are joined by a single rope called the “**tackle**”.

NOTE:

- Velocity ratio is equal to the number of strings supporting the movable block.
- Velocity ratio is also equal to the number of pulleys on the system.
- The effort applied is equal to the tension in each string supporting the movable block.
- For an odd number of pulleys in the system, the fixed block should have one more pulley than the movable block.
- For an even number of pulleys in the system, the fixed and the movable blocks should have the same number of pulleys.

PASSING THE STRINGS (ROPES):

- ❖ If the number of pulleys is odd (velocity ratio is odd), the string must be tied and start from the movable block.
- ❖ If the number of pulleys is even (velocity ratio is even), the string must be tied and start from the fixed block.

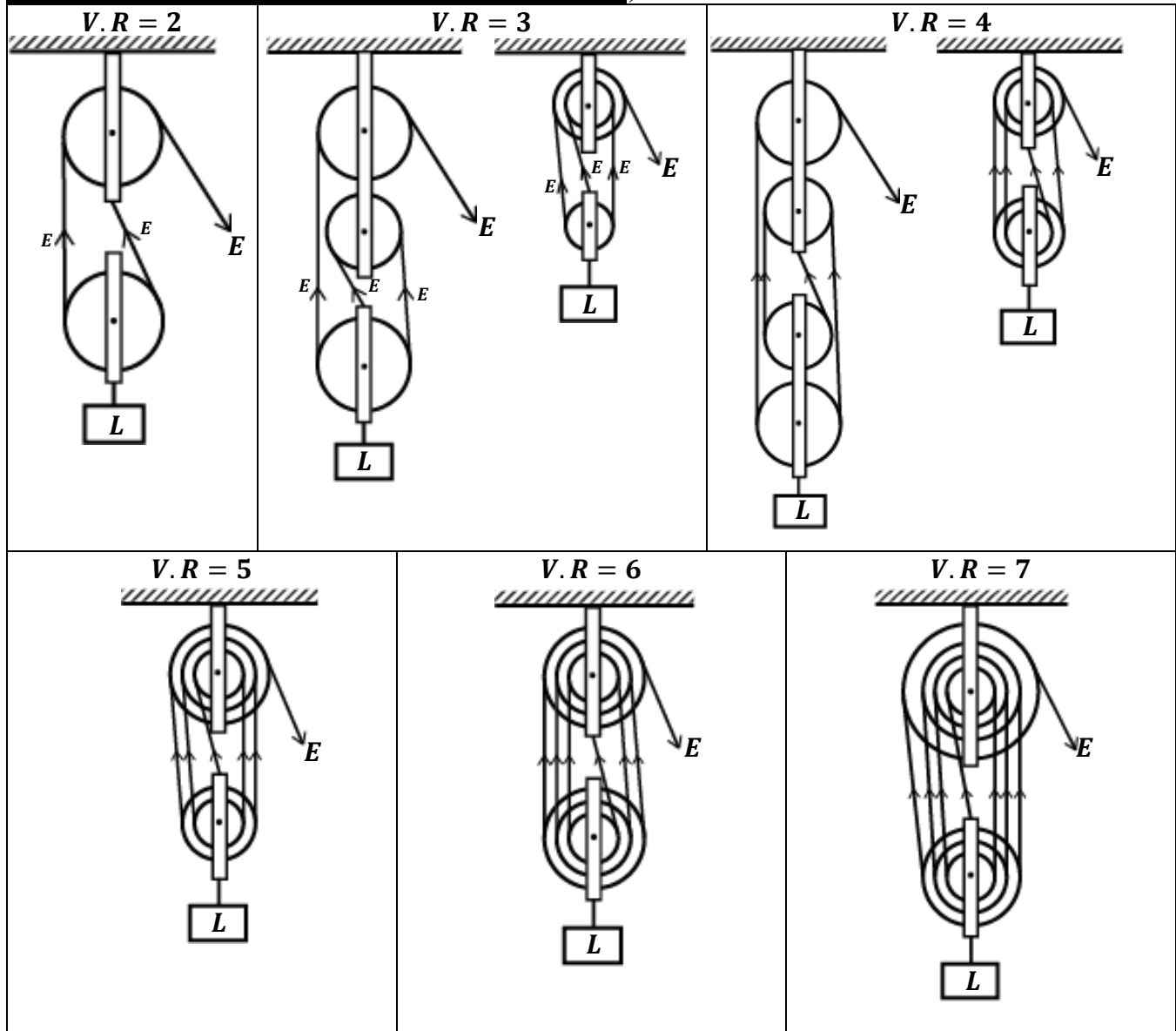
Examples of block and tackle pulley systems include;

Examples:

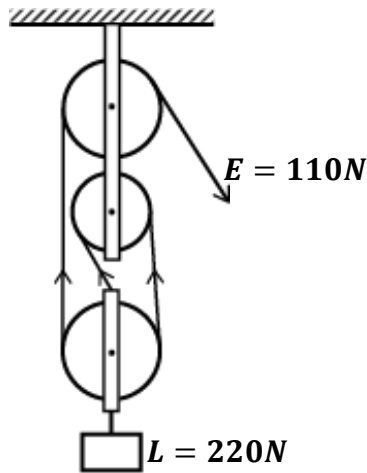
1. A block and tackle pulley system shown in the figure below is used to lift a load of 220N when an effort of 110N is applied.
 - (i) State the velocity ratio of the system.
 - (ii) Calculate the mechanical advantage of the system.
 - (iii) Calculate the efficiency of the pulley system.



(i) **Velocity ratio = 3**

(ii) Mechanical advantage

$$M.A = \frac{L}{E}$$

$$M.A = \frac{220}{110}$$

$$M.A = 2$$

(iii) Efficiency

$$\eta = \frac{M.A}{V.R} \times 100\%$$

$$\eta = \frac{2}{3} \times 100\%$$

$$\eta = 66.7\%$$

2. A pulley system of velocity ratio 5 is used to lift a load of 500N. The effort needed is found to be 200N.

- a) Draw the arrangement of the above system.
b) Calculate the efficiency of the system.

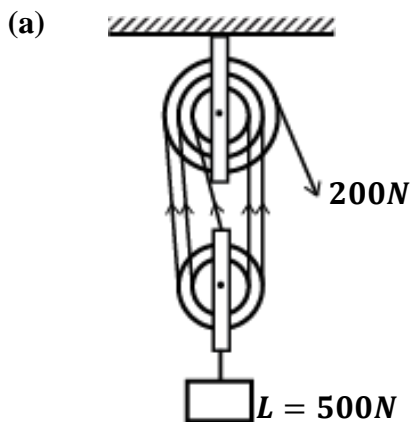

(b) **V.R = 5**

Mechanical advantage

$$M.A = \frac{L}{E}$$

$$M.A = \frac{500}{200}$$

$$M.A = 2.5$$

Efficiency

$$\eta = \frac{M.A}{V.R} \times 100\%$$

$$\eta = \frac{2.5}{5} \times 100\%$$

$$\eta = 0.5 \times 100\%$$

$$\eta = 50\%$$

3. A man uses a block and tackle pulley system to raise a load of 720N through a distance of 10m using an effort of 200N. If the pulley system has a velocity ratio of 5, find the;

a) Mechanical advantage.

$$M.A = \frac{L}{E}$$

$$M.A = \frac{720}{200}$$

$$M.A = 3.6$$

b) Efficiency.

$$V.R = 5$$

$$\eta = \frac{M.A}{V.R} \times 100\%$$

$$\eta = \frac{3.6}{5} \times 100\%$$

$$\eta = 0.72 \times 100\%$$

$$\eta = 72\%$$

c) Distance moved by effort.

$$D_L = 10m, D_E = ?$$

$$V.R = \frac{D_E}{D_L}$$

$$5 = \frac{D_E}{10}$$

$$D_E = 5 \times 10$$

$$D_E = 50m$$

d) Work input.

$$D_E = 50m, \quad E = 200N$$

$$W.I = E \times D_E$$

$$W.I = 200 \times 50$$

$$W.I = 10,000J$$

e) Work output.

$$D_L = 10m, \quad L = 720N$$

$$W.O = L \times D_L$$

$$W.O = 720 \times 10$$

$$W.O = 7200J$$

f) Energy wasted

$$\text{Energy wasted} = W.I - W.O$$

$$E.W = 10,000 - 7,200$$

$$E.W = 2,800J$$

4. A block and tackle pulley system with a velocity ratio of 5 and 60% efficient is used to lift a load of 60kg through a vertical height of 2m. Calculate the effort that must be applied on the system.

$$V.R = 5, \quad \eta = 60\%, \quad L = 60 \times 10 = 600N, \quad D_L = 2m$$

$$\eta = \frac{M.A}{V.R} \times 100\%$$

$$60\% = \frac{M.A}{5} \times 100\%$$

$$60\% \times 5 = 100\% M.A$$

$$M.A = \frac{300\%}{100\%}$$

$$M.A = 3$$

$$M.A = \frac{L}{E}$$

$$3 = \frac{600}{E}$$

$$E = \frac{600}{3}$$

$$E = 200N$$

5. Below is a frictionless pulley system of velocity ratio 4.

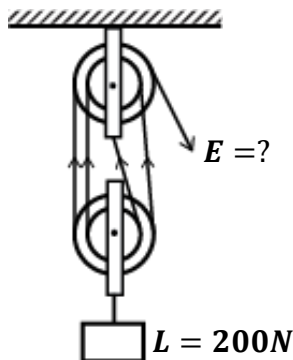

If the weight of the pulley system is 4N, calculate;

- Effort required to raise the load.
- Mechanical advantage of the system.
- Efficiency of the system.

Upward forces = Downward forces

Sum of Tension (Efforts) in the strings = Load + Weight of pulleys + Friction

$$E + E + E + E = 200 + 4 + 0$$

$$4E = 204$$

$$E = \frac{204}{4}$$

$$E = 51N$$

Mechanical advantage

$$M.A = \frac{L}{E}$$

$$M.A = \frac{200}{51}$$

$$M.A = 3.92$$

Efficiency

$$V.R = 4$$

$$\eta = \frac{M.A}{V.R} \times 100\%$$

$$\eta = \frac{3.92}{4} \times 100\%$$

$$\eta = 0.98 \times 100\%$$

$$\eta = 98\%$$

6. The pulley system below has a mass of 0.6kg

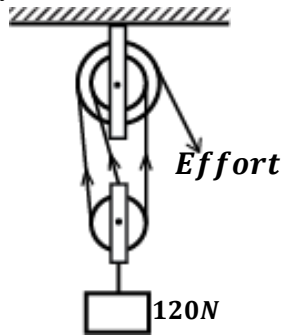

Calculate;

- Effort required to raise the load.
- Mechanical advantage.
- Efficiency of the pulley system.

(i) Effort
Weight of pulley = mg
 $W = 0.6 \times 10 = 6N$

Upward forces = Downward forces
 $E + E + E = L + W$
 $3E = 120 + 6$
 $E = \frac{126}{3}$
 $E = 42N$

(ii) Mechanical advantage

$$M.A = \frac{L}{E}$$

$$M.A = \frac{120}{42}$$

$$M.A = 2.86$$

(iii) Efficiency
 $V.R = 3$

$$\eta = \frac{M.A}{V.R} \times 100\%$$

$$\eta = \frac{2.86}{3} \times 100\%$$

$$\eta = 95.3\%$$

7.

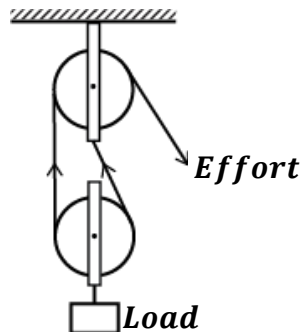

The figure besides shows a load of 10N being raised slowly by the aid of a simple frictionless pulley system.

- State the velocity ratio of the system.
- Calculate the effort required to raise the load if the mass of each pulley is 0.2kg.
- If the load is raised through a distance of 5m, calculate the efficiency of the pulley system.

(i) **Velocity ratio = 2**

(ii) Effort
Weight of movable pulley = mg
 $W = 0.2 \times 10 = 2N$

Upward forces = Downward forces
 $E + E = L + W$
 $2E = 10 + 2$
 $E = \frac{12}{2}$
 $E = 6N$

Mechanical advantage

$$M.A = \frac{L}{E}$$

$$M.A = \frac{10}{6}$$

$$M.A = 1.667$$

(iii) Efficiency
 $V.R = 2$

$$\eta = \frac{M.A}{V.R} \times 100\%$$

$$\eta = \frac{1.667}{2} \times 100\%$$

$$\eta = 0.8335 \times 100\%$$

$$\eta = 83.35\%$$

EXERCISE:

1. The effort required to raise a load of 100N is 40N as shown below.

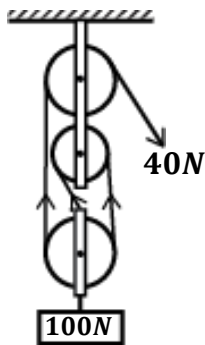

Calculate;

- Mechanical advantage.
- Efficiency.
- Work done on the load if it is raised through a distance of 6m.

- A block and tackle pulley system is used to lift a mass of 2000kg. If this machine has a velocity ratio of 5 and an efficiency of 80%,
 - Sketch a possible arrangement of the pulleys.
 - Calculate the mechanical advantage of the system.
 - Determine the effort applied.
- An effort of 125N is used to lift a load of 500N through a height of 2.5m using a pulley system. If the distance moved by the effort is 15m, calculate;
 - the work done on the load.
 - the work done by the effort.
 - Efficiency of the pulley system.
- An effort of 50N is required to raise a load of 200N using a pulley system of velocity ratio 5.
 - Draw a diagram to show the pulley system.
 - Find the efficiency of the system.
 - Calculate the work wasted when the load is raised through 120cm.
 - Give two reasons why the efficiency of the above pulley is less than 100%.
- A pulley system of velocity ratio 3 supports a load of 20N. given that the tension in each string is 8N, calculate;
 - The effort required to raise the load.
 - The mechanical advantage.
 - The efficiency of the pulley system.
 - The distance moved by the effort if the load moves through a distance of 2m.
 - The weight of the lower pulley.
- Draw a diagram showing a single string pulley system of velocity ratio 6. Given that the weight of the lower block and the pulleys is 10N, calculate the efficiency of the pulley system if an effort of 1500N is required to raise a load of 4990N.
- A block and tackle pulley system has a velocity ratio of 4. If its efficiency is 75%, find;
 - Mechanical advantage.
 - Load that can be lifted with an effort of 500N.
 - Work done if the load is raised through a vertical distance of 4.0m.

EXPERIMENT TO SHOW THE VARIATION OF MECHANICAL ADVANTAGE OR EFFICIENCY OF PULLEY SYSTEM WITH THE LOAD

(Experiment to determine efficiency of a pulley system)

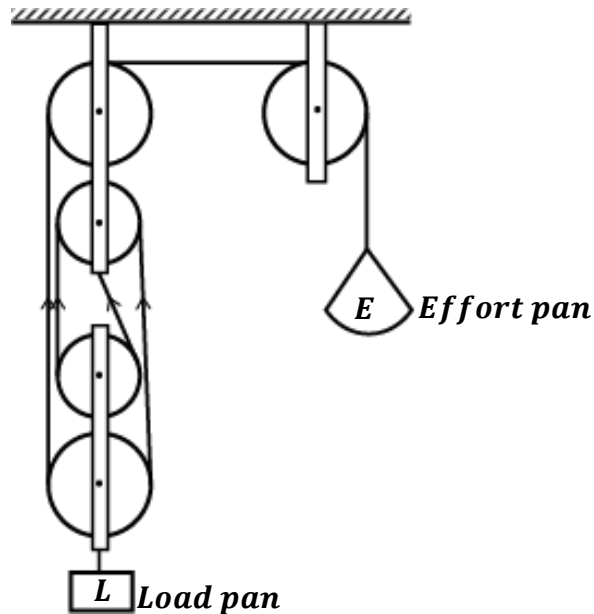

- A known load (L) is placed on the load pan.
- Known weights are added on the effort pan until the load just begins to rise upwards.
- The total weight (E) on the effort pan is noted and recorded.
- The experiment is repeated with different loads.
- The results are put in a suitable table including values of mechanical advantage and efficiency.
- A graph of efficiency against load is plotted.

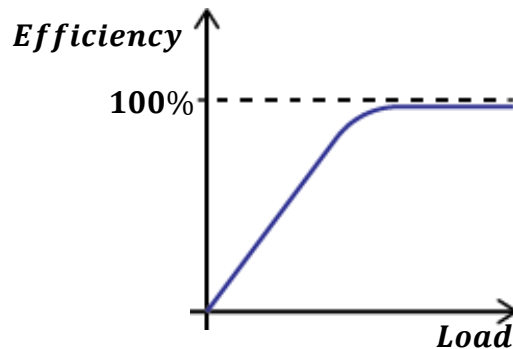

Explanation of the graph:

As the load increases, the efficiency of the pulley system also increases. This is because;

- When the load is small, a large effort is used to overcome friction force between moving parts and lift the weight of the movable block. This leads to a small mechanical advantage and small efficiency for a small load.
- When the load is increased, the friction force and the weight of the movable become very small. Therefore, a large portion of the effort is used to lift the load while a small portion of the effort overcomes friction and lifts the weight of the movable block. This leads to a large mechanical advantage and large efficiency for a small load.

NOTE:

- ❖ The velocity ratio of the above pulley system is 4 but not 5 since we consider the arrangement of pulleys where the load is attached.
- ❖ The of table of results is as shown below.

$L(N)$	$E(N)$	$\frac{L}{E}$ (M.A)	$\frac{M.A}{V.R} \times 100\%$ (Efficiency)

- ❖ If the variation of mechanical advantage with load is required, then a graph of mechanical advantage is plotted as shown below.

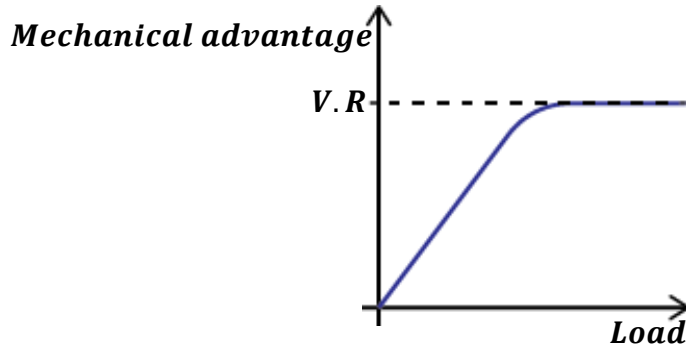
APPLICATIONS (USES) OF PULLEYS

- They are used at construction sites to lift heavy building materials from the ground.
- They are used in raising (hoisting) flags.
- They are used in lifts and elevators.
- They are used in cranes for loading and offloading ships at ports.
- They are used in fetching water from underground wells.
- They are used in drawing stage curtains in theatres.

INCLINED PLANES

An inclined plane is a sloping surface or plane inclined at angle to the ground.

An inclined plane allows a load to be raised using a small effort than it were to be lifted vertically upwards.

Examples of inclined planes;

- Stair cases.
- Raising cows up to the truck using a sloping piece of wood.
- Sloping roads in mountains.

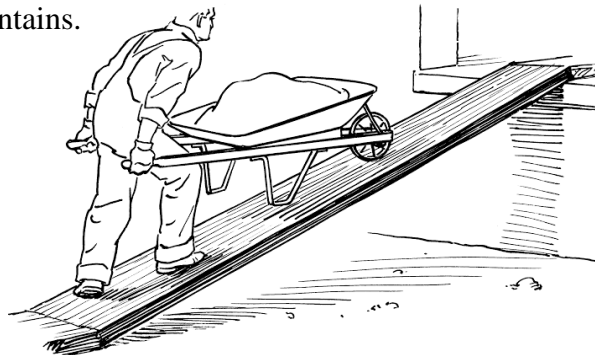

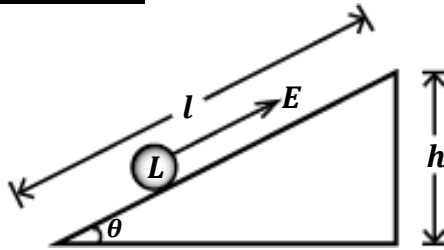
Structure of an inclined plane

The distance moved by the effort (D_E) = length of the plane (l)

The distance moved by the load (D_L) = height of the plane (h)

Velocity ratio of an inclined plane:

$$V.R = \frac{\text{Distance moved by the effort } (D_E)}{\text{Distance moved by the load } (D_L)}$$

$$V.R = \frac{\text{length of the plane}}{\text{height of the plane}}$$

$$V.R = \frac{l}{h}$$

NOTE; Considering the angle of inclination, θ ;

$$\text{Since, } \sin\theta = \frac{h}{l} = \frac{1}{V.R}$$

$$\text{Therefore, } V.R = \frac{1}{\sin\theta}$$

Examples:

1. A brick of weight 20N is lifted through a height of 3m along a smooth inclined plane of length 15m by applying an effort of 5N as shown below.

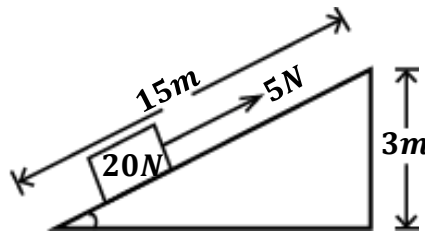

Calculate;

i) Mechanical advantage
 $L = 20N, \quad E = 5N$

$$M.A = \frac{L}{E}$$

$$M.A = \frac{20}{5}$$

$$M.A = 4$$

ii) Velocity ratio
 $D_L = 3m, \quad D_E = 15m$

$$V.R = \frac{D_E}{D_L}$$

$$V.R = \frac{15}{3}$$

$$V.R = 5$$

iii) Efficiency

$$\eta = \frac{M.A}{V.R} \times 100\%$$

$$\eta = \frac{4}{5} \times 100\%$$

$$\eta = 0.8 \times 100\%$$

$$\eta = 80\%$$

2. A load of 400N is pulled along an inclined plane as shown below.

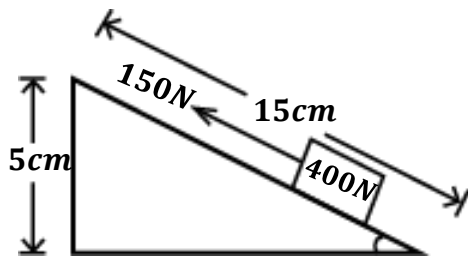

Calculate;

- Work input.
- Work output.
- Efficiency of the plane.

- i) Work input.

$$D_E = 15\text{cm} = \frac{15}{100} = 0.15\text{m},$$

$$E = 150\text{N}$$

$$W.I = E \times D_E$$

$$W.I = 150 \times 0.15$$

$$W.I = 22.5\text{J}$$

- ii) Work output.

$$D_L = 5\text{cm} = \frac{5}{100} = 0.05\text{m},$$

$$L = 400\text{N}$$

$$W.O = L \times D_L$$

$$W.O = 400 \times 0.05$$

$$W.O = 20\text{J}$$

- iii) Efficiency

$$\eta = \frac{W.O}{W.I} \times 100\%$$

$$\eta = \frac{20}{22.5} \times 100\%$$

$$\eta = 88.9\%$$

3. An inclined plane shown below was used to lift a load of 50kg using an effort of 200N.

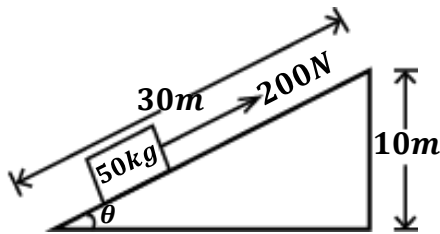

Calculate;

- Mechanical advantage.
- Velocity ratio.
- Efficiency.
- Angle of inclination.

- i) Mechanical advantage

$$L = mg$$

$$L = 50 \times 10 = 500\text{N},$$

$$E = 200\text{N}$$

$$M.A = \frac{L}{E}$$

$$M.A = \frac{500}{200}$$

$$M.A = 2.5$$

- ii) Velocity ratio

$$D_L = 10\text{m}, \quad D_E = 30\text{m}$$

$$V.R = \frac{l}{h}$$

$$V.R = \frac{30}{10}$$

$$V.R = 3$$

- iii) Efficiency

$$\eta = \frac{M.A}{V.R} \times 100\%$$

$$\eta = \frac{2.5}{3} \times 100\%$$

$$\eta = 83.3\%$$

- iv) Angle of inclination

$$\sin \theta = \frac{h}{l} = \frac{10}{30} = \frac{1}{3}$$

$$\theta = \sin^{-1} \left(\frac{1}{3} \right)$$

$$\theta = 19.5^\circ$$

4. A woman uses an inclined plane to lift a load of 500N through a vertical distance of 4m. the inclined plane makes an angle of 30° to the horizontal. If the efficiency of the inclined plane is 72%, calculate the effort need to raise the load.

$$l = ?, \quad h = 4\text{m}$$

$$\sin \theta = \frac{h}{l}$$

$$\sin 30^\circ = \frac{4}{l}$$

$$l \sin 30^\circ = 4$$

$$l = \frac{4}{\sin 30^\circ} = 8\text{m}$$

Then;

$$V.R = \frac{l}{h} = \frac{8}{4}$$

$$V.R = 2$$

$$\eta = \frac{M.A}{V.R} \times 100\%$$

$$72\% = \frac{M.A}{2} \times 100\%$$

$$M.A = 1.44$$

$$M.A = \frac{L}{E}$$

$$1.44 = \frac{500}{E}$$

$$E = 347.2\text{N}$$

EXERCISE:

1. An effort of 50N is used to move a 300N box along an inclined which rises vertically 1m for every 8m distance along the plane. Find
 - i) the velocity ratio.
 - ii) the mechanical advantage.
 - iii) the efficiency of the inclined plane.

2. A body of 100N is moved along a sloped wooden plank PQ by an effort of 90N as shown below.

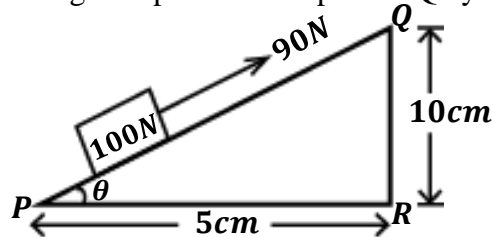

Calculate;

- a) the length of the plane.
 - b) angle of inclination.
 - c) velocity ratio.
 - d) Mechanical advantage.
 - e) Efficiency of the plane.
3. A trolley of weight 10N is pulled from the bottom to the top of the inclined plane by a steady force of 2N. If the height and the distance moved by the force are 2m and 20m respectively, calculate;
 - a) Mechanical advantage.
 - b) Work done by the effort.
 - c) Work done on the load.
 - d) Efficiency of the inclined plane.
4. A load of 40N is pulled steadily along an 80% efficient inclined plane by a force, F as shown below. Find the
 - i) Velocity ratio of the system
 - ii) Mechanical advantage.
 - iii) Force, F.

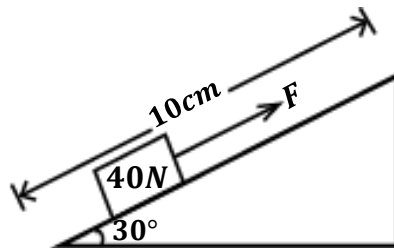

WHEEL AND AXLE



It consists of a wheel of large radius attached to an axle of small radius. The wheel and axle have a common axis of rotation.

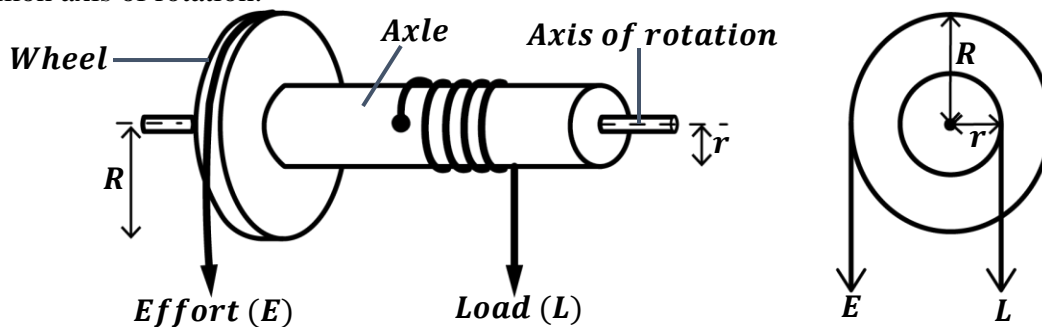

The effort (E) is applied to one end of the rope passing over the wheel of radius, R while the load is applied at the other end of the rope passing over the axle of radius, r .

The wheel and the axle are circular therefore, for one complete turn;

- ❖ The effort moves through a distance equal to the circumference of the wheel ($2\pi R$).
- ❖ The load moves through a distance equal to the circumference of the axle ($2\pi r$).

Velocity ratio of a wheel and axle:

$$V.R = \frac{\text{Distance moved by the effort } (D_E)}{\text{Distance moved by the load } (D_L)}$$

$$V.R = \frac{2\pi R}{2\pi r}$$

$$V.R = \frac{R}{r}$$

Therefore, velocity ratio of a wheel and axle is given by;

$$V.R = \frac{\text{Radius of the wheel } (R)}{\text{Radius of the axle } (r)}$$

Examples:

1. A machine consisting of a wheel of radius 50cm and axle of radius 10cm is used to lift a load of 400N with an effort of 100N. Calculate the efficiency of the machine.

Mechanical advantage
 $L = 400N, \quad E = 100N$
 $M.A = \frac{L}{E}$
 $M.A = \frac{400}{100}$
 $M.A = 4$

Velocity ratio
 $R = 50cm, \quad r = 10cm$
 $V.R = \frac{R}{r}$
 $V.R = \frac{50}{10}$
 $V.R = 5$

Efficiency
 $\eta = \frac{M.A}{V.R} \times 100\%$
 $\eta = \frac{4}{5} \times 100\%$
 $\eta = 0.8 \times 100\%$
 $\eta = 80\%$

2. The efficiency of the machine below is 75%.

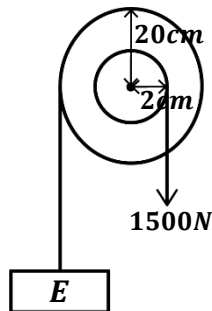

Calculate;

- its velocity ratio.
- its mechanical advantage.
- the effort applied.

i) Velocity ratio
 $R = 20cm, \quad r = 2cm$
 $V.R = \frac{R}{r}$
 $V.R = \frac{20}{2}$
 $V.R = 10$

ii) Mechanical advantage
 $\eta = \frac{M.A}{V.R} \times 100\%$
 $75\% = \frac{M.A}{10} \times 100\%$
 $75\% \times 10 = 100\% M.A$
 $M.A = \frac{750\%}{100\%}$
 $M.A = 7.5$

iii) Effort
 $M.A = \frac{L}{E}$
 $7.5 = \frac{1500}{E}$
 $E = \frac{1500}{7.5}$
 $E = 200N$

- 3.

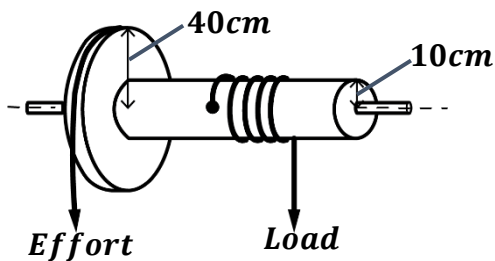

The figure besides shows a wheel and axle. When an effort of 300N is applied, a load of 900N is raised.

Calculate;

- Work output.
- Work input.
- Efficiency.

$$R = 40cm = \frac{40}{100} = 0.4m$$

$$r = 10cm = \frac{10}{100} = 0.1m$$

Effort distance, $D_E = 2\pi R = 2 \times \pi \times 0.4 = 0.8\pi \text{ m}$
Load distance, $D_L = 2\pi r = 2 \times \pi \times 0.1 = 0.2\pi \text{ m}$

i) Work output

$$L = 900\text{N}$$

$$W.O = L \times D_L$$

$$W.O = 900 \times 0.2\pi$$

$$W.O = 180\pi \text{ J}$$

ii) Work input

$$E = 900\text{N}$$

$$W.I = E \times D_E$$

$$W.I = 300 \times 0.8\pi$$

$$W.I = 240\pi \text{ J}$$

iii) Efficiency

$$\eta = \frac{\text{Work output}}{\text{Work input}} \times 100\%$$

$$\eta = \frac{180\pi}{240\pi} \times 100\%$$

$$\eta = 0.75 \times 100\%$$

$$\eta = 75\%$$

4. In a wheel and axle machine, an effort of 10N raises a load of 30N. The radius of the wheel is 150mm and the radius of the axle is 30mm. Find the efficiency of the machine.

Mechanical advantage
 $L = 30\text{N}, \quad E = 10\text{N}$

$$M.A = \frac{L}{E}$$

$$M.A = \frac{30}{10}$$

$$M.A = 3$$

Velocity ratio
 $R = 150\text{mm}, \quad r = 30\text{mm}$

$$V.R = \frac{R}{r}$$

$$V.R = \frac{150\text{mm}}{30\text{mm}}$$

$$V.R = 5$$

Efficiency

$$\eta = \frac{M.A}{V.R} \times 100\%$$

$$\eta = \frac{3}{5} \times 100\%$$

$$\eta = 0.6 \times 100\%$$

$$\eta = 60\%$$

5. The diagram below shows a 75% simple machine used to raise a load of 72N.

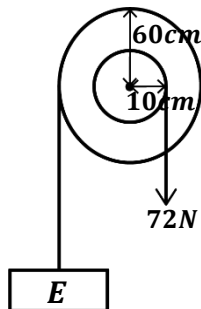

- a) Name the type of machine above.

Wheel and axle

- b) Determine the effort required to raise the load.

Velocity ratio
 $R = 60\text{cm}, \quad r = 10\text{cm}$

$$V.R = \frac{R}{r}$$

$$V.R = \frac{60}{10}$$

$$V.R = 6$$

Mechanical advantage

$$\eta = \frac{M.A}{V.R} \times 100\%$$

$$75\% = \frac{M.A}{6} \times 100\%$$

$$75\% \times 6 = 100\% M.A$$

$$M.A = \frac{450\%}{100\%}$$

$$M.A = 4.5$$

Effort

$$M.A = \frac{L}{E}$$

$$4.5 = \frac{72}{E}$$

$$E = \frac{72}{4.5}$$

$$E = 16\text{N}$$

Applications of wheel and axle in daily life

- It is applied in screw drivers.
- It is applied in steering wheels in cars.
- It is applied in a wind las to draw water from wells.

EXERCISE

1. A machine consists of a wheel of 40cm and an axle of radius 10cm. If an effort of 20N raises a load of 60N, find the efficiency of the machine.

2. The system below is a wheel and axle of radii 40cm and 4cm respectively.

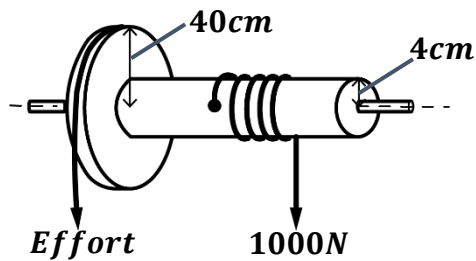

Assuming that the efficiency of the system is 50%, calculate;

- Effort required.
- Work output.
- Work input.
- Energy wasted.

3. A wheel and axle machine is constructed from a wheel of diameter 20cm and mounted on an axle of diameter 4cm.

a) Calculate;

- Velocity ratio of the machine.
- Mechanical advantage of the machine if its 100%.

b) Explain why the actual mechanical advantage of this machine is likely to be less than the value obtained above.

4. A common windlass is used to raise a load of 480N by an application of an effort 200N at right angles to the handle. If the handle has a radius of 33cm from the axis and the radius of the axle is 11cm, calculate;

- Velocity ratio.
- Efficiency of the windlass.

GEARS

A gear is a device consisting of a set of toothed wheels that control the movement (speed) of a machine.



Applications of gears in daily life

They are applied in;

- Clocks
- Motors
- Bicycles
- Watches
- Motor vehicles

In gears;

- ❖
- ❖ The effort is applied to the shaft of the small gear (wheel) called a **driving wheel**.
- ❖ The load is applied to the shaft of the large gear (wheel) called a **driven wheel**.

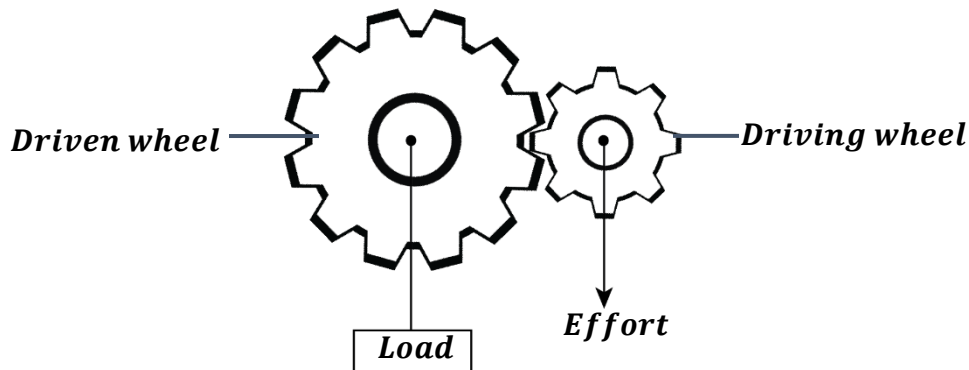

NOTE:

- The more the number of teeth on the gear, the less the speed of rotation of the gear and the less the number of teeth on the gear, the higher the speed of rotation of the gear.
- Therefore, the fastest gear is the driving wheel with the smallest number of teeth.

Velocity ratio of a gear system:

Velocity ratio of a gear system may be given by the following formulae;

$$V.R = \frac{\text{Number of teeth of driven wheel}}{\text{Number of teeth of driving wheel}}$$

$$V.R = \frac{\text{Speed of rotation of driven wheel}}{\text{Speed of rotation of driving wheel}}$$

$$V.R = \frac{\text{Number of revolutions of driving wheel}}{\text{Number of revolutions of driven wheel}}$$

Examples:

1. A driving wheel of 25 teeth interlocks with another wheel of 100 teeth. The gear system has an efficiency of 85%.

Calculate;

- a) Velocity ratio.
- b) Mechanical advantage of the system.

a)

$$\begin{aligned} \text{No. of teeth on driving wheel} &= 25 \\ \text{No. of teeth on driven wheel} &= 100 \end{aligned}$$

$$V.R = \frac{\text{Number of teeth of driven wheel}}{\text{Number of teeth of driving wheel}}$$

$$V.R = \frac{100}{25}$$

$$V.R = 4$$

b)

$$\eta = \frac{M.A}{V.R} \times 100\%$$

$$85\% = \frac{M.A}{4} \times 100\%$$

$$85\% \times 4 = 100\% M.A$$

$$M.A = \frac{340\%}{100\%}$$

$$M.A = 3.4$$

2. A bicycle has 120 teeth in the driven gears and 40 teeth in the driving gears. Calculate;
- Velocity ratio.
 - Mechanical advantage if the bicycle is 80% efficient.

a) Velocity ratio

$$\text{No. of teeth on driving wheel} = 40$$

$$\text{No. of teeth on driven wheel} = 120$$

$$V.R = \frac{\text{Number of teeth of driven wheel}}{\text{Number of teeth of driving wheel}}$$

$$V.R = \frac{120}{40}$$

$$V.R = 3$$

b) Mechanical advantage

$$\eta = \frac{M.A}{V.R} \times 100\%$$

$$80\% = \frac{M.A}{3} \times 100\%$$

$$80\% \times 3 = 100\% M.A$$

$$M.A = \frac{240\%}{100\%}$$

$$M.A = 2.4$$

3. In a gear system, the driven wheel has 40 teeth and the driving wheel has 10 teeth. The system is used to carry a load of 300N when an effort of 100N is applied. Determine;

- Velocity ratio.
- Mechanical advantage.
- Efficiency.

i) Velocity ratio

$$\text{No. of teeth on driving wheel} = 10$$

$$\text{No. of teeth on driven wheel} = 40$$

$$V.R = \frac{\text{Number of teeth of driven wheel}}{\text{Number of teeth of driving wheel}}$$

$$V.R = \frac{40}{10}$$

$$V.R = 4$$

ii) M.A

$$M.A = \frac{L}{E}$$

$$M.A = \frac{300}{100}$$

$$M.A = 3$$

iii) Efficiency

$$\eta = \frac{M.A}{V.R} \times 100\%$$

$$\eta = \frac{3}{4} \times 100\%$$

$$\eta = 0.75 \times 100\%$$

$$\eta = 75\%$$

4. A certain gear has 60 teeth and drives another gear with 150 teeth. How many revolutions will the driven gear make when the driving gear makes 200 revolutions.

Velocity ratio

$$\text{No. of teeth on driving wheel} = 60$$

$$\text{No. of teeth on driven wheel} = 150$$

$$V.R = \frac{\text{Number of teeth of driven wheel}}{\text{Number of teeth of driving wheel}}$$

$$V.R = \frac{150}{60}$$

$$V.R = 2.5$$

$$V.R = \frac{\text{Number of revolutions of driving wheel}}{\text{Number of revolutions of driven wheel}}$$

$$2.5 = \frac{200}{R}$$

$$R = \frac{200}{2.5}$$

$$R = 80 \text{ revolutions}$$

5. The figure below shows two gear wheels.

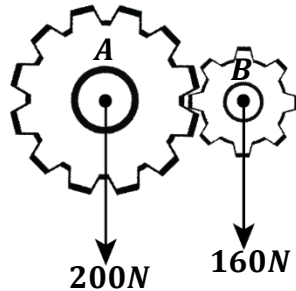

- a) How should gears A and B engage each other so that a low mechanical advantage is obtained.
A should be the driven gear since it has more teeth and B should be the driving gear since it has less teeth.
- b) Calculate the efficiency of the gear system.

Velocity ratio

$$\begin{aligned} \text{No. of teeth on driving wheel} &= 8 \\ \text{No. of teeth on driven wheel} &= 12 \end{aligned}$$

$$V.R = \frac{\text{Number of teeth of driven wheel}}{\text{Number of teeth of driving wheel}}$$

$$V.R = \frac{12}{8}$$

$$V.R = 1.5$$

M.A

$$\begin{aligned} M.A &= \frac{L}{E} \\ M.A &= \frac{200}{160} \\ M.A &= 1.25 \end{aligned}$$

Efficiency

$$\begin{aligned} \eta &= \frac{M.A}{V.R} \times 100\% \\ \eta &= \frac{1.25}{1.5} \times 100\% \\ \eta &= 83.3\% \end{aligned}$$

6. Two gear wheels A and B with 80 and 20 teeth respectively lock into each other. They are fastened to axles such that a weight of 150N attached to one axle of the gear wheel B raises a load of 450N attached to another axle of the gear wheel A as shown below.

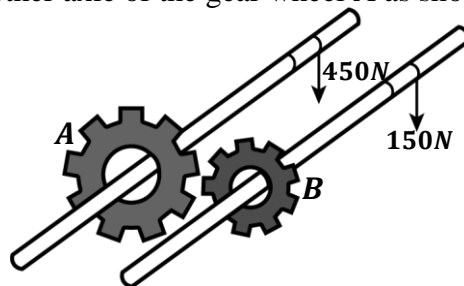

Calculate;

- i) Velocity ratio

$$\begin{aligned} \text{No. of teeth on driving wheel B} &= 20 \\ \text{No. of teeth on driven wheel A} &= 80 \end{aligned}$$

$$V.R = \frac{\text{Number of teeth of driven wheel}}{\text{Number of teeth of driving wheel}}$$

$$V.R = \frac{80}{20}$$

$$V.R = 4$$

- ii) M.A

$$\begin{aligned} M.A &= \frac{L}{E} \\ M.A &= \frac{450}{150} \\ M.A &= 3 \end{aligned}$$

- iii) Efficiency

$$\begin{aligned} \eta &= \frac{M.A}{V.R} \times 100\% \\ \eta &= \frac{3}{4} \times 100\% \\ \eta &= 0.75 \times 100\% \\ \eta &= 75\% \end{aligned}$$

EXERCISE:

- A bicycle has a chain wheel with 32 teeth, and the driven wheel has 80 teeth. If the efficiency is 88%, find the;
 - Velocity ratio.
 - Mechanical advantage.
- A gear with 30 teeth drives another gear with 75 teeth. How many revolutions will the driven gear make when the driving gear makes 100 revolutions.
- Two gear wheels A and B with 20 teeth and 10 teeth respectively are fastened together such that the weight of 160N is attached to one wheel and rises a load of 400N applied on the other wheel. If wheel B drives A, Calculate;
 - Velocity ratio of the system.
 - Efficiency.
- A gear has a driven wheel moving at 20ms^{-1} and a driving wheel moving at 4ms^{-1} . The gear carries a load of 300N and is overcome by an effort of 150N. Calculate the efficiency of the gear system.
- In the gear system below, N_1 and N_2 are the number of teeth on the system. The gear system has an efficiency of 60%.

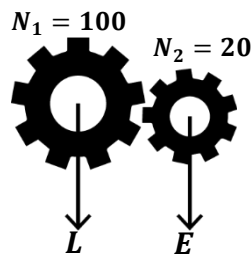

Calculate;

- Velocity ratio.
- Load that can be raised by an effort of 200N.

SCREWS

This is a device with thread-like windings on it. It is used to fix or hold materials together.

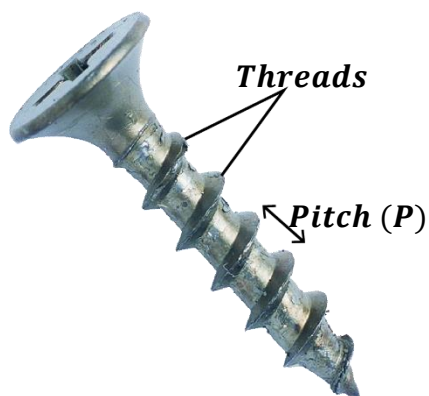

Pitch of a screw:

This is the distance between any two successive threads of a screw.

NOTE:

- ❖ In order to use a screw, a screw driver or brace or screw jack is used to drive screws in and out of the material.
- ❖ An effort is applied on the handles of those devices above to drive the screw (load) in and out of the material.

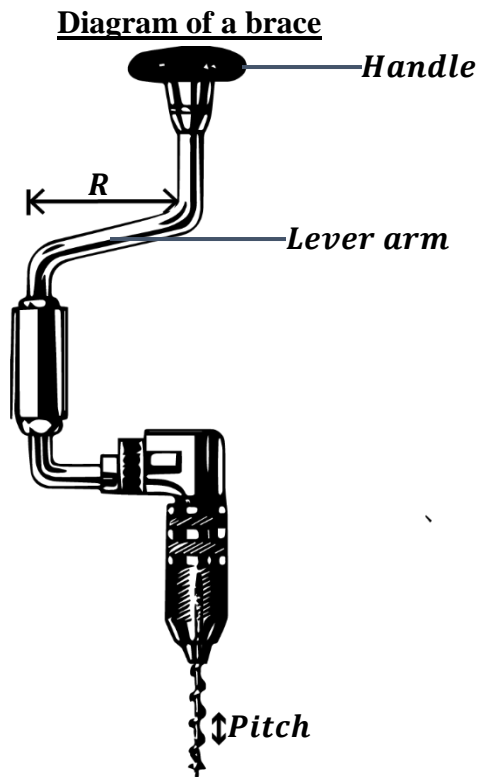

- ❖ When the handle moves through one complete turn (complete circular path), the screw enters or leaves the wood through a distance equal to the pitch of the screw.
- ❖ Distance moved by the effort in one complete turn is equal to the circumference of a circle described by the handle.

Effort distance = circumference of circle described by handle

$$D_E = 2\pi R$$

(Where radius, R of the circle is equal to the length of the lever arm)

- ❖ Distance moved by the load (screw) in one complete turn is equal to the pitch of the screw.

Load distance = Pitch of the screw

$$D_L = P$$

Velocity ratio of a screw:

$$V.R = \frac{\text{Distance moved by the effort } (D_E)}{\text{Distance moved by the load } (D_L)}$$

$$V.R = \frac{\text{Circumference of a circle described by handle}}{\text{Pitch of the screw}}$$

$$V.R = \frac{2\pi R}{Pitch}$$

Examples:

1. In a screw jack, the length of the lever arm is 56cm and a pitch of 4cm. It is used to lift a load. Calculate its velocity ratio.

$$R = 56cm, \quad Pitch = 4cm$$

$$V.R = \frac{2\pi R}{Pitch}$$

$$V.R = \frac{2 \times \frac{22}{7} \times 56}{4} = \frac{352}{4}$$

$$V.R = 88$$

2. A screw of pitch 5cm is used to lift a load of 890.8N in a car jack. The lever makes a circle of circumference 10cm and has an efficiency of 85%.

Calculate;

- Velocity ratio of screw.
- Mechanical advantage of screw.
- Effort applied on the handle.

- a) Velocity ratio

$$C = 56cm, \quad P = 5cm$$

$$V.R = \frac{Circumference}{Pitch}$$

$$V.R = \frac{10}{5}$$

$$V.R = 2$$

- b) Mechanical advantage

$$\eta = \frac{M.A}{V.R} \times 100\%$$

$$85\% = \frac{M.A}{2} \times 100\%$$

$$85\% \times 2 = 100\% M.A$$

$$M.A = \frac{170\%}{100\%}$$

$$M.A = 1.7$$

- c) Effort

$$M.A = \frac{L}{E}$$

$$1.7 = \frac{890.8}{E}$$

$$E = \frac{890.8}{1.7}$$

$$E = 524N$$

3. A screw has a pitch of 5mm. If an effort of 30N is rotated through one turn of radius 50cm to lift a load of 750N, find;

- Velocity ratio.
- Mechanical advantage.
- Efficiency.

- i) Velocity ratio

$$R = 50cm,$$

$$Pitch = 5mm = \frac{5}{10} = 0.5cm$$

$$V.R = \frac{2\pi R}{Pitch}$$

$$V.R = \frac{2 \times 3.14 \times 50}{0.5} = \frac{314}{0.5}$$

$$V.R = 628$$

- ii) M.A

$$M.A = \frac{L}{E}$$

$$M.A = \frac{750}{30}$$

$$M.A = 25$$

- iii) Efficiency

$$\eta = \frac{M.A}{V.R} \times 100\%$$

$$\eta = \frac{25}{628} \times 100\%$$

$$\eta = 0.0398 \times 100\%$$

$$\eta = 3.98\%$$

4. A screw with a lever arm of 56cm has two successive threads which are 2.5mm apart. It is used to lift a load of 800N. If its 25% efficient, calculate the mechanical advantage of the screw.

d) Velocity ratio

$$R = 56\text{cm},$$

$$\text{Pitch} = 2.5\text{mm} = \frac{2.5}{10} = 0.25\text{cm}$$

$$V.R = \frac{2\pi R}{\text{Pitch}}$$

$$V.R = \frac{2 \times \frac{22}{7} \times 56}{0.25} = \frac{352}{0.25}$$

$$V.R = 1408$$

e) Mechanical advantage

$$\eta = \frac{M.A}{V.R} \times 100\%$$

$$25\% = \frac{M.A}{1408} \times 100\%$$

$$25\% \times 1408 = 100\% M.A$$

$$M.A = \frac{35200\%}{100\%}$$

$$M.A = 352$$

5. The handle of a screw jack is 14cm long. The screw jack is used to drive a screw of pitch 20cm. if an effort of 5N is applied on the jack to move a screw of 15N, calculate

i) Velocity ratio.

ii) Mechanical advantage.

iii) Efficiency.

i) Velocity ratio

$$R = 14\text{cm},$$

$$\text{Pitch} = 20\text{cm}$$

$$V.R = \frac{2\pi R}{\text{Pitch}}$$

$$V.R = \frac{2 \times \frac{22}{7} \times 14}{20} = \frac{88}{20}$$

$$V.R = 4.4$$

ii) M.A

$$M.A = \frac{L}{E}$$

$$M.A = \frac{15}{5}$$

$$M.A = 3$$

iii) Efficiency

$$\eta = \frac{M.A}{V.R} \times 100\%$$

$$\eta = \frac{3}{4.4} \times 100\%$$

$$\eta = 68.2\%$$

6. A screw has 6 successive threads and describes a circular path of diameter 0.28mm when a screw driver is attached to it. Determine the velocity ratio of the machine if the distance between the 6 threads is 0.12mm.

$$R = \frac{\text{diameter}}{2} = \frac{0.28}{2} = 0.14\text{mm}$$

There are 5 pitches between the 6 threads.

$$5P = 0.12\text{mm}$$

$$P = \frac{0.12}{5} = 0.024\text{mm}$$

$$V.R = \frac{2\pi R}{\text{Pitch}}$$

$$V.R = \frac{2 \times \frac{22}{7} \times 0.14}{0.024} = \frac{0.88}{0.024}$$

$$V.R = 36.67$$

NOTE:

- The velocity ratio of the screw is always very large because the length of the handle is very big compared to the pitch of the screw.
- The efficiency is always very low because screws have a very high friction since the threads are very rough. This helps screws to firmly hold materials together.

EXERCISE:

- The pitch of a screw jack is 2.5mm. With a lever arm of 56cm long, the jack is used to lift a car of mass 790kg. if the screw jack is 75% efficient, determine;
 - Velocity ratio
 - Mechanical advantage.
 - Effort applied.
- The pitch of a bolt is 1mm. to tighten the bolt, Ssekwe uses a spanner of a long arm of length 80cm. Calculate the velocity ratio of the spanner.
- A screw jack is found to be 70% efficient. If an effort of 20N is used to lift a vehicle of 5000N and the pitch of the screw is 2mm. What is the length of the lever arm.
- A screw of pitch 2.5cm is used to raise a load of 200kg when an effort of 50N is applied to the screw arm of length 20cm. Calculate;
 - Mechanical advantage.
 - Velocity ratio.
 - Efficiency.
- A Screw jack of pitch 2.5mm is operated by a force of 100N acting at a distance of 7cm from the axis about which the handle rotates and lifts a car weighing 792kg. calculate its efficiency.

HYDRAULIC PRESS OR LIFT

It's a device used to lift a large load using a small effort. Its operation is based on the knowledge of Pascal's principle. (*See topic: Pressure*)

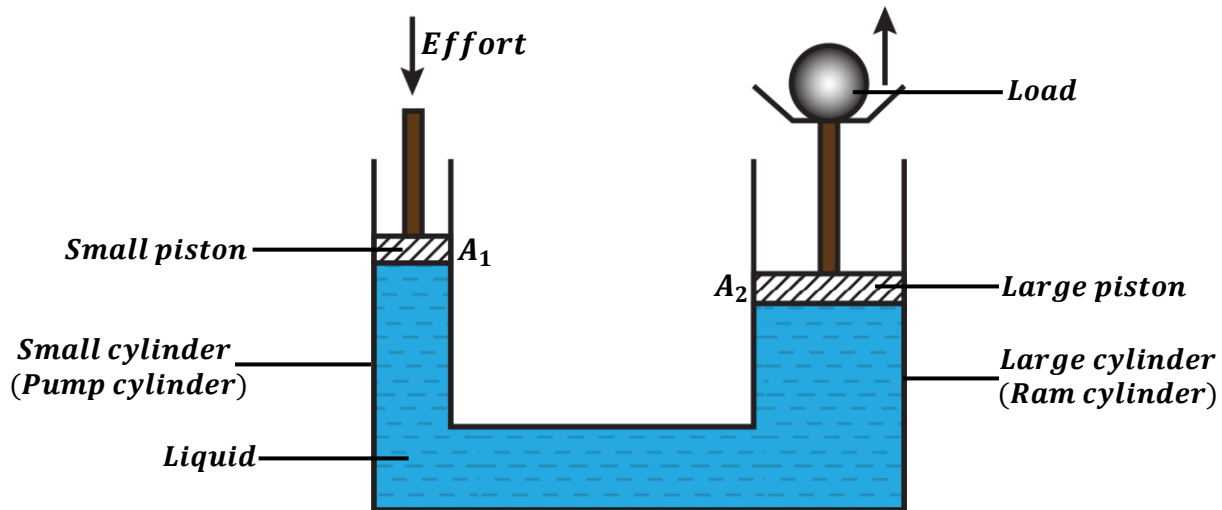
Velocity ratio of a hydraulic press:

Let D_E be the distance moved by the small piston and A_1 be the area of the small piston.

Let D_L be the distance moved by the small piston and A_2 be the area of the large piston.

When an effort is applied on the small piston:

- The volume of the liquid pushed down by the small piston is equal to the volume of the liquid lifts up the large piston with the load.

RECALL: **Volume = Area × Distance**

Volume of liquid pushed down small piston = Volume of liquid lifting large piston

$$A_1 \times D_E = A_2 \times D_L$$

$$\frac{D_E}{D_L} = \frac{A_2}{A_1}$$

- Since the pistons are circular, their areas equal to the area of a circle.

$$A_1 = \pi r^2, \quad A_2 = \pi R^2$$

Then,

$$\frac{D_E}{D_L} = \frac{A_2}{A_1} = \frac{\pi R^2}{\pi r^2}$$

Therefore;

$$V.R = \frac{D_E}{D_L} = \frac{R^2}{r^2}$$

Where R – Radius of the large piston.
 r – Radius of the small piston.
 D_E – Distance moved by the effort.
 D_L – Distance moved by the load.

Examples:

1. The radius of the effort piston of a hydraulic lift is 1.4cm while that of the load piston is 7.0cm. This machine is used to raise a load of 1200N. Given that the machine is 80% efficient, calculate;

- Velocity ratio
- Mechanical advantage.
- Effort applied.

<p>a) Velocity ratio</p> $r = 1.4\text{cm}, \quad R = 7\text{cm}$ $V.R = \frac{R^2}{r^2}$ $V.R = \frac{7^2}{1.4^2}$ $V.R = 25$	<p>b) Mechanical advantage</p> $\eta = \frac{M.A}{V.R} \times 100\%$ $80\% = \frac{M.A}{25} \times 100\%$ $80\% \times 25 = 100\% M.A$ $M.A = \frac{2000\%}{100\%}$ $M.A = 20$	<p>c) Effort</p> $M.A = \frac{L}{E}$ $20 = \frac{1200}{E}$ $E = \frac{1200}{20}$ $E = 60\text{N}$
--	--	---

2. A hydraulic press is used to lift 400N using an effort of 20N. The diameter of the large cylinder is 100cm and the diameter of the small cylinder is 10cm. Find;

<p>i) Velocity ratio</p> $r = \frac{10}{2} = 5\text{cm}, \quad R = \frac{100}{2} = 50\text{cm}$ $V.R = \frac{R^2}{r^2}$ $V.R = \frac{50^2}{5^2}$ $V.R = 100$	<p>ii) M.A</p> $M.A = \frac{L}{E}$ $M.A = \frac{400}{20}$ $M.A = 20$	<p>iii) Efficiency</p> $\eta = \frac{M.A}{V.R} \times 100\%$ $\eta = \frac{20}{100} \times 100\%$ $\eta = 0.2 \times 100\%$ $\eta = 20\%$
--	--	---

3. A hydraulic machine has a ram cylinder (large cylinder) of diameter 30cm and a pump cylinder (small cylinder) of diameter 2cm. If the effort applied to the small piston is 70N and the efficiency of the machine is 80%, calculate the;
- Velocity ratio
 - Mechanical advantage.
 - Load lifted.

a) Velocity ratio

$$r = \frac{2}{2} = 1cm, \quad R = \frac{30}{2} = 15cm$$

$$V.R = \frac{R^2}{r^2}$$

$$V.R = \frac{15^2}{1^2}$$

$$V.R = 225$$

b) Mechanical advantage

$$\eta = \frac{M.A}{V.R} \times 100\%$$

$$80\% = \frac{M.A}{225} \times 100\%$$

$$80\% \times 225 = 100\%M.A$$

$$M.A = \frac{18000\%}{100\%}$$

$$M.A = 180$$

c) Effort

$$M.A = \frac{L}{E}$$

$$180 = \frac{L}{70}$$

$$L = 180 \times 70$$

$$L = 12600N$$

EXERCISE:

- A hydraulic machine has a large cylinder of 30cm and a small cylinder of 1cm. Given that the machine is 80% efficient and that the effort applied on the small piston is 50N, calculate;
 - Velocity ratio
 - Mechanical advantage.
 - Maximum load that can be raised.
- The area of the effort piston of a hydraulic lift is $56cm^2$ while that of the load piston is $224cm^2$. This machine is used to raise a load of 300kg through a height of 2.5mm. given that the machine is 75% efficient, calculate;
 - Velocity ratio
 - Mechanical advantage.
 - Effort applied.
 - Distance moved by the effort.

NOTE:

- If two simple machines are combined together, the overall velocity ratio is equal to the product of the individual velocity ratios of the two machines.

$$V.R = \text{Velocity ratio of machine 1} \times \text{Velocity ratio of machine 2}$$

REFRACTION THROUGH PRISMS

A prism has two refracting surfaces. It uses a principle of reversibility of light, therefore light can be incident on either surface.

When a ray of light is incident on the first surface at an angle of incidence i_1 , it is refracted at an angle of refraction, r_1 with an angle of deviation, d_1 .

The ray then emerges out on the second surface at an angle of emergence i_2 , with an angle of refraction, r_2 and angle of deviation, d_2 .

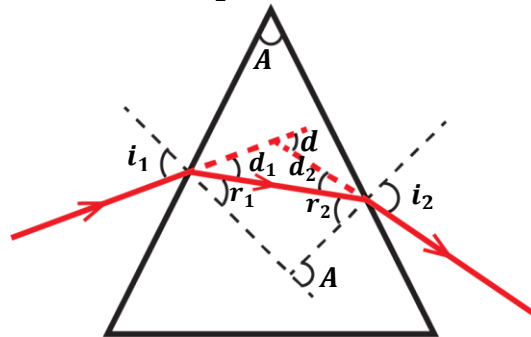

Angle of deviation, $d_1 = i_1 - r_1$

Angle of deviation, $d_2 = i_2 - r_2$

Total angle of deviation, $d = d_1 + d_2$

$$d = (i_1 - r_1) + (i_2 - r_2)$$

$$d = i_1 + i_2 - r_1 - r_2$$

$$d = (i_1 + i_2) - (r_1 + r_2)$$

But $A = r_1 + r_2$

$$d = (i_1 + i_2) - A$$

where A is the refracting angle of prism

NOTE:

If a ray of light does not emerge out but instead grazes on one surface of the prism, then the angle of refraction at that surface is equal to the critical angle.

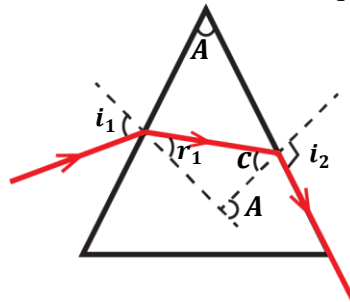

N.B:

For calculations involving prisms, it is easier to consider refractions at each side separately using the law of reversibility of light.

Examples:

1. A ray of light is incident on a glass prism of refractive index 1.5 at an angle of 40° . Given that the ray emerges out an angle of 58.4° . Find the;
 - i) angle of refraction at both surfaces
 - ii) refracting angle of the prism.
 - iii) total deviation of the prism.

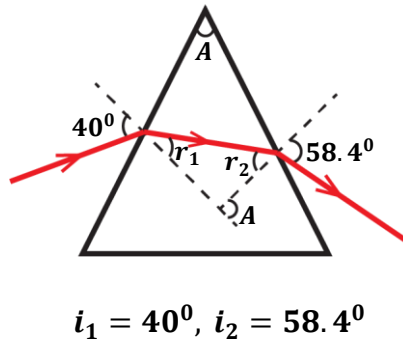

$i_1 = 40^\circ, i_2 = 58.4^\circ$

i)
Refraction at first surface
 $n_1 \sin i = n_2 \sin r$
 $n_a \sin i_1 = n_g \sin r_1$
 $1 \times \sin 40^\circ = 1.5 \times \sin r_1$
 $0.6428 = 1.5 \sin r_1$
 $\sin r_1 = \frac{0.6428}{1.5}$
 $\sin r_1 = 0.4285$
 $r_1 = \sin^{-1}(0.4285)$
 $r_1 = 25.4^\circ$

Refraction at second surface
 $n_1 \sin i = n_2 \sin r$
 $n_a \sin i_2 = n_g \sin r_2$
 $1 \times \sin 58.4^\circ = 1.5 \times \sin r_2$
 $0.8517 = 1.5 \sin r_2$
 $\sin r_2 = \frac{0.8517}{1.5}$
 $\sin r_2 = 0.5678$
 $r_2 = \sin^{-1}(0.5678)$
 $r_2 = 34.6^\circ$

ii)
Refracting angle
 $A = r_1 + r_2$
 $A = 25.4^\circ + 34.6^\circ$
 $A = 60^\circ$

ii)
Total deviation
 $d = (i_1 + i_2) - A$
 $d = (40^\circ + 58.4^\circ) - 60^\circ$
 $d = 98.4^\circ - 60^\circ$
 $d = 38.4^\circ$

2. A ray of light propagating from a liquid is incident on a prism of refracting angle 50° and refractive index 1.6 at an angle of 30° as shown below.

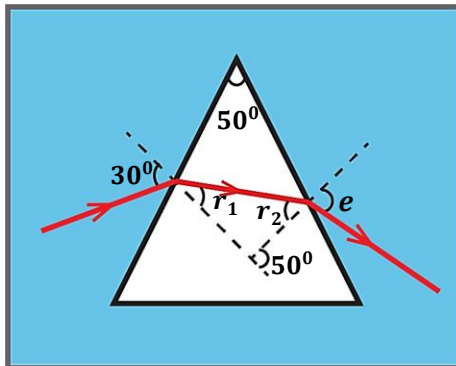

If the refractive index of the liquid is 1.35. Calculate

- i) Angle of refraction, r_1 and r_2
- ii) Angle of emergence, e
- iii) Angle of deviation

i)

Refraction at first surface

$$\begin{aligned} n_1 \sin i &= n_2 \sin r \\ n_l \sin i_1 &= n_g \sin r_1 \\ 1.35 \times \sin 30^\circ &= 1.6 \times \sin r_1 \\ 0.6750 &= 1.6 \sin r_1 \\ \sin r_1 &= \frac{0.6750}{1.6} \\ \sin r_1 &= 0.4219 \\ r_1 &= \sin^{-1}(0.4219) \\ r_1 &= 25.0^\circ \end{aligned}$$

$$\begin{aligned} A &= r_1 + r_2 \\ 50^\circ &= 25.0^\circ + r_2 \\ r_2 &= 25.0^\circ \end{aligned}$$

ii)

Refraction at second surface

$$\begin{aligned} n_1 \sin i &= n_2 \sin r \\ n_l \sin e &= n_g \sin r_2 \\ 1.35 \times \sin e &= 1.6 \times \sin 25^\circ \\ 1.35 \sin e &= 0.6762 \\ \sin e &= \frac{0.6762}{1.35} \\ \sin e &= 0.5009 \\ e &= \sin^{-1}(0.5009) \\ e &= 30.1^\circ \end{aligned}$$

iii)

Total deviation

$$\begin{aligned} d &= (i_1 + i_2) - A \\ d &= (30^\circ + 30.1^\circ) - 50^\circ \\ d &= 60.1^\circ - 50^\circ \\ d &= 10.1^\circ \end{aligned}$$

3. A ray of light is incident at an angle of incidence, i a triangular prism of refractive index 1.52 as shown below. Find the angles marked c , r and i .

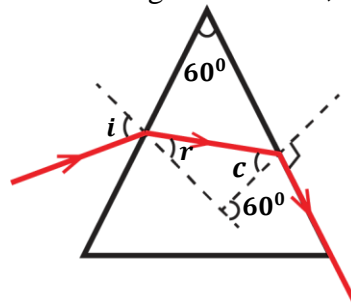

Refraction at second surface

$$\begin{aligned} n_1 \sin i &= n_2 \sin r \\ n_a \sin i_2 &= n_g \sin r_2 \\ 1 \times \sin 90^\circ &= 1.52 \times \sin c \\ 1 &= 1.52 \sin c \\ \sin c &= \frac{1}{1.52} \\ \sin c &= 0.6579 \\ c &= \sin^{-1}(0.6579) \\ c &= 41.1^\circ \end{aligned}$$

$$\begin{aligned} A &= r_1 + r_2 \\ 60^\circ &= r + c \\ 60^\circ &= r + 41.1^\circ \\ r &= 60^\circ - 41.1^\circ \\ r &= 18.9^\circ \end{aligned}$$

Refraction at second surface

$$\begin{aligned} n_1 \sin i &= n_2 \sin r \\ n_a \sin i_1 &= n_g \sin r_1 \\ 1 \times \sin i &= 1.52 \times \sin 18.9^\circ \\ \sin i &= 0.4924 \\ i &= \sin^{-1}(0.4924) \\ i &= 29.5^\circ \end{aligned}$$

4. The figure below shows light incident normally on a glass prism in air.

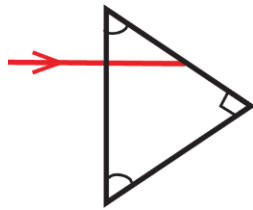

a) Copy and complete the diagram.

b) Calculate the refractive index of the prism if the critical angle of glass is 42°

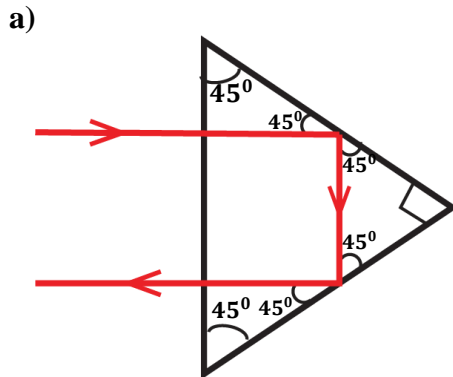

b)

$$n_g = \frac{1}{\sin c}$$

$$n_g = \frac{1}{\sin 42^\circ}$$

$$n_g = 1.49$$

The ray took that path since the angle of incidence is greater than the critical angle of glass i.e. $45^\circ > 42^\circ$

EXERCISE

1. A prism of refractive index 1.5 and refracting angle 60° has an angle of refraction 28° on the first refracting face. Determine;

- i) Angle of incidence (**Ans: 44.8°**)
- ii) Angle of refraction on second refracting surface (**Ans: 32°**)
- iii) Angle of emergence (**Ans: 52.6°**)
- iv) Angle of deviation (**Ans: 37.4°**)

2. A ray of light is incident on a glass prism at an angle, i as shown below.

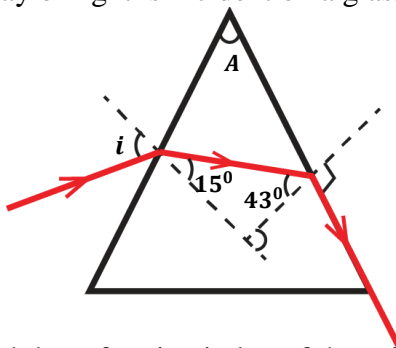

Find the refractive index of the prism, refracting angle and angle of incidence, i .

Ans: $n_g = 1.47, A = 58^\circ, i = 27^\circ$

3. A ray of light is incident on a glass prism of an angle, i as shown below.

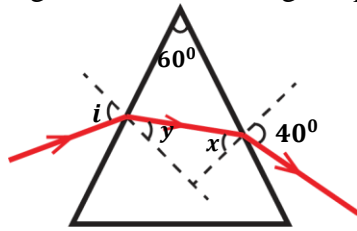

If the refractive index of the prism is 1.5, find the angles marked x , y , and i .

Ans: $x = 25.4^\circ$, $y = 34.6^\circ$, $i = 59.4^\circ$

4. The diagram below shows a ray of yellow light incident at an angle of 50° on one side of an equilateral triangular glass prism of refractive index 1.52.

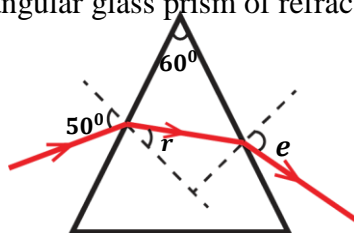

Calculate the angles marked r and e .

Ans: $r = 30.3^\circ$, $e = 48.9^\circ$

Experiment to determine the refractive index of glass using a glass prism:

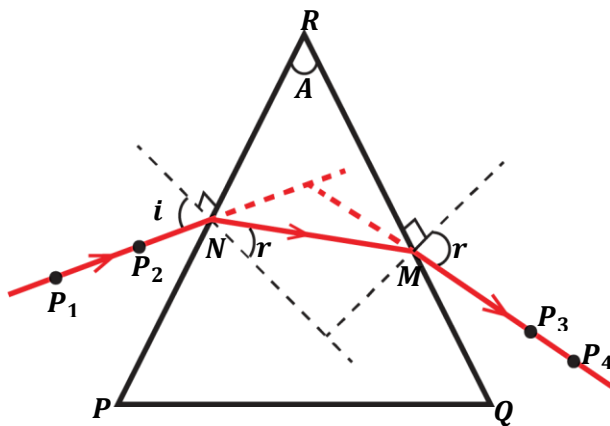

Procedures;

- Fix a white sheet of paper on a soft board using drawing pins.
- Place a glass prism on the white sheet of paper and draw its outline PQR.
- Remove the glass prism and draw a normal at N to meet PQ.
- Using a protractor, measure angle of incidence, i from the normal and fix two pins P_1 and P_2 along it.
- Replace the glass prism back to its outline.
- Look through the glass prism from the opposite side QR and fix pins P_3 and P_4 such that they appear to be in line with the images of pins P_1 and P_2 .
- Remove the glass prism and the pins P_3 and P_4 .
- Draw a line to join the marks of pins P_3 and P_4 to meet at M and then join N to M.
- Measure the angle of refraction, r .

- Repeat the procedures above for different values of i .
- Tabulate your results including values of $\sin i$ and $\sin r$.

$i(^{\circ})$	$r(^{\circ})$	$\sin i$	$\sin r$

- Plot a graph of $\sin i$ against $\sin r$.
- Determine the slope of the graph.

Conclusion:

- The graph is a straight line and its slope is equal to the refractive index of the glass prism.

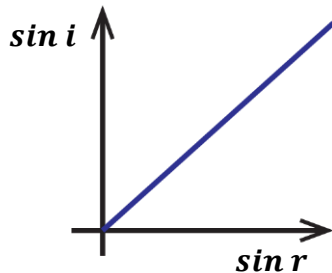

REFRACTION THROUGH LENSES

Lenses are spherical surfaces made from a transparent material. The materials used to make these lenses may be glass, plastics and water.

Types of lenses;

There are two types of lenses namely;

- Convex (converging) lenses.
- Concave (diverging lenses).

CONVERGING (CONVEX) LENSES:

These are thicker in the middle than at the edges.

A convex lens is called a converging lens because all parallel rays incident to it meet at one point after refraction.

Examples of converging lenses include;



DIVERGING (CONCAVE) LENSES:

These are thicker at the edges than in the middle.

A concave lens is called a diverging lens because all parallel rays incident to it appear to diverge from one point after refraction.

Examples of diverging lenses include;



TERMS USED IN LENSES

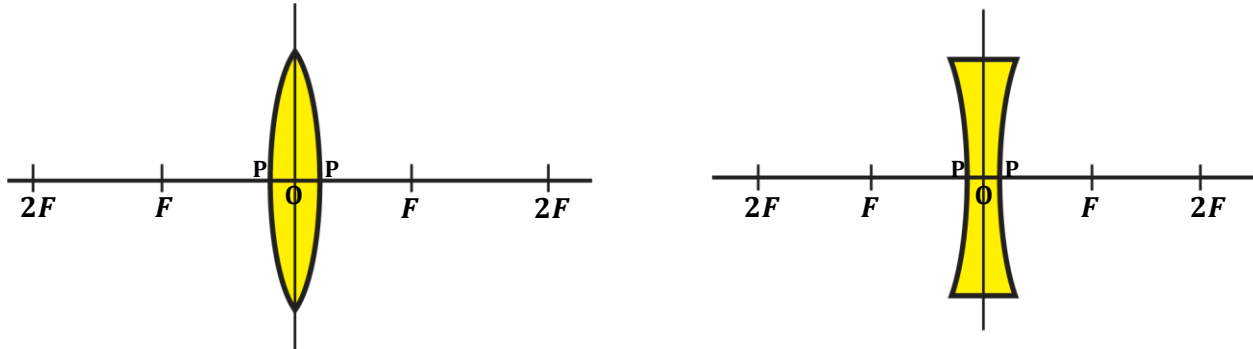

Pole of a lens (P):

This is the mid-point of the surface of the lens.

Optical centre (O):

This is the centre of the lens between its poles.

Principal axis:

This is a straight line passing through the optical centre and principal focus of a lens.

Principal focus, F of a converging lens:

This is a point on the principal axis where all rays close and parallel to the principal axis converge to after refraction.

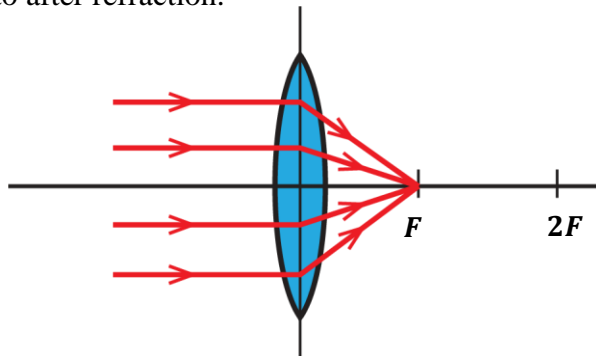

Principal focus, F of a diverging lens:

This is a point on the principal axis where all rays close and parallel to the principal axis appear to diverge from after refraction.

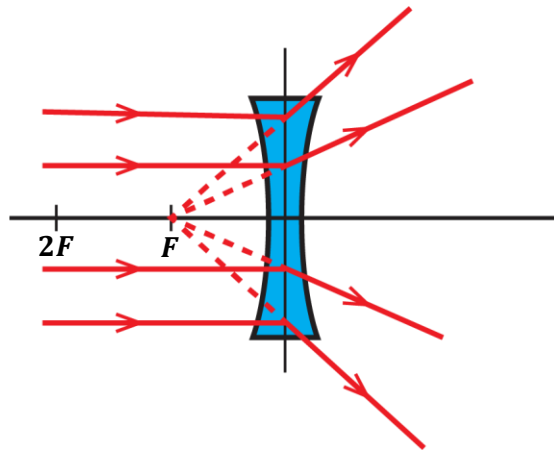

Focal length (f):

This is the distance between the optical centre and the principal focus of the lens.

RULES FOR DRAWING RAY DIAGRAMS IN LENSES

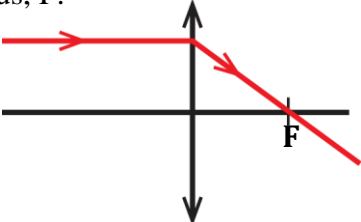
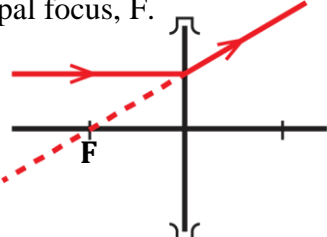
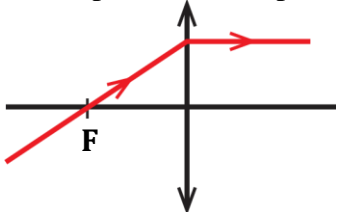
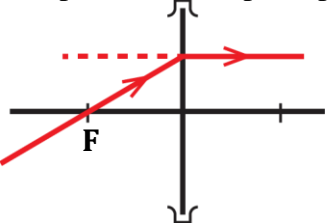
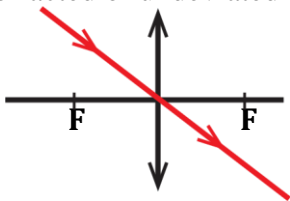
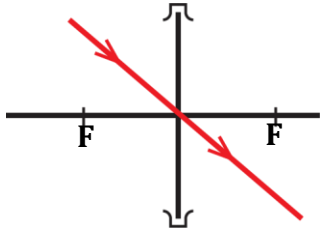
CONVERGING LENS	DIVERGING LENS
<p>1. A ray parallel to the principal axis is refracted passing through the principal focus, F.</p> 	<p>A ray parallel to the principal axis is refracted such that it appears to be coming from the principal focus, F.</p> 
<p>2. A ray passing through the principal focus is refracted parallel to the principal axis.</p> 	<p>A ray that pass through the principal focus is refracted parallel to the principal axis.</p> 
<p>3. A ray passing through the optical centre is not refracted or undeviated</p> 	<p>A ray passing through the optical centre is not refracted or undeviated</p> 

IMAGES FORMED BY CONVEX (CONVERGING) LENSES

The nature of the image formed depends on the position of the object from the lens.

(a) Object beyond 2F:

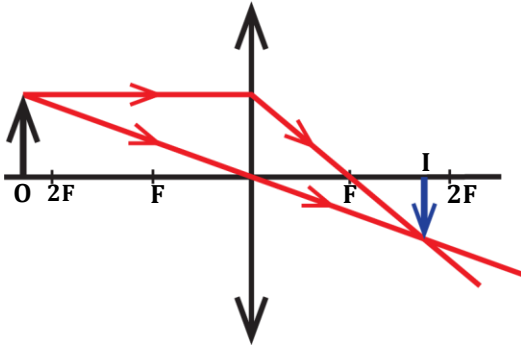

Nature of image, I formed:

- ✓ Between F and 2F.
- ✓ Real
- ✓ Inverted (upside down)
- ✓ Diminished (smaller than object)

(b) Object at 2F:

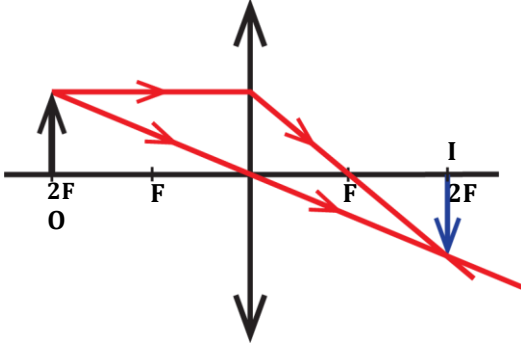

Nature of image, I formed:

- ✓ Between at 2F.
- ✓ Real
- ✓ Inverted (upside down)
- ✓ Same size as object

(c) Object between 2F and F:

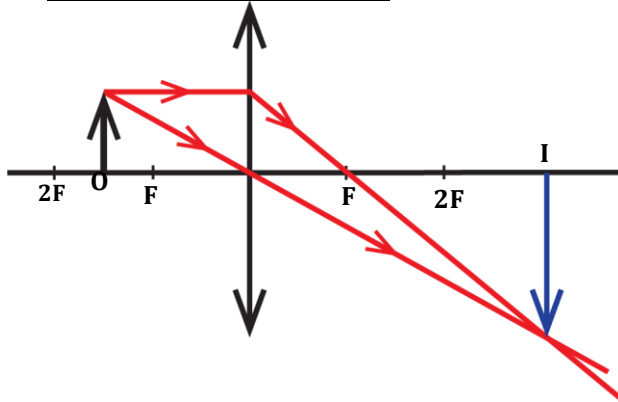

Nature of image, I formed:

- ✓ Beyond 2F.
- ✓ Real
- ✓ Inverted (upside down)
- ✓ Magnified (bigger than object)

(d) Object at F:

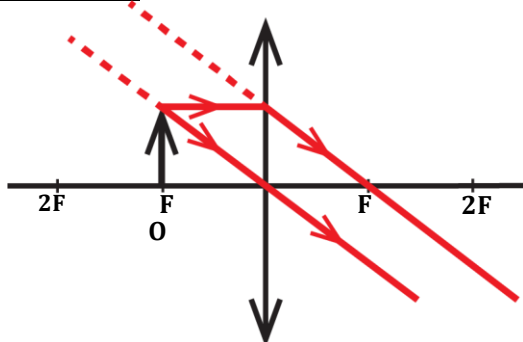

Nature of image, I formed:

- ✓ At infinity.
- ✓ Magnified

(e) Object between F and optical centre:

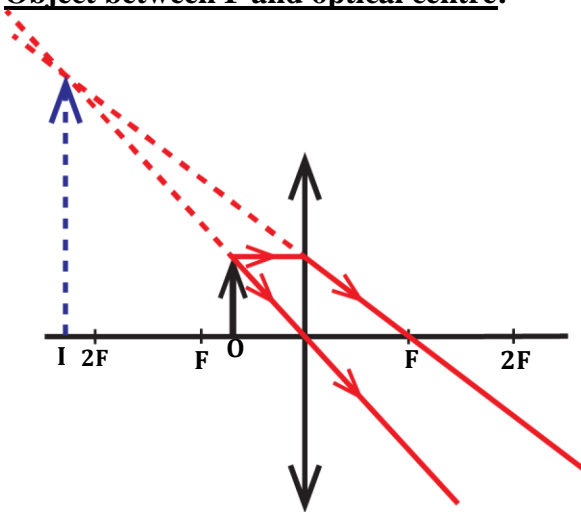

Nature of image, I formed:

- ✓ Beyond 2F.
- ✓ Virtual
- ✓ Upright
- ✓ Magnified

NOTE:

A converging lens acts as a magnifying glass when the object is placed between the principal focus and the optical centre.

(f) Object at infinity:

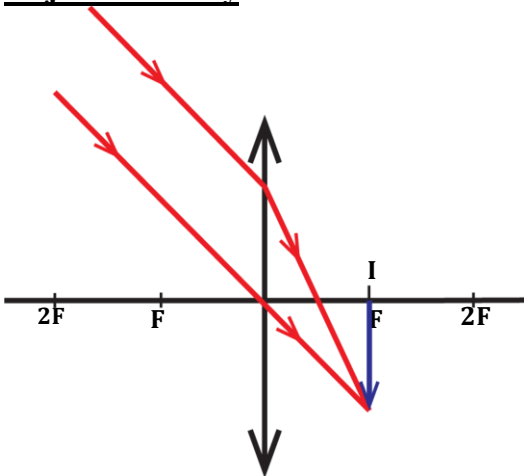

Nature of image, I formed:

- ✓ Formed at F.
- ✓ Real
- ✓ Inverted (upside down)
- ✓ Diminished (smaller than object)

QN:

Explain how a converging lens can be used as a magnifying glass.

A converging lens can be used as a magnifying glass when the object is placed between the principal focus and the optical centre.

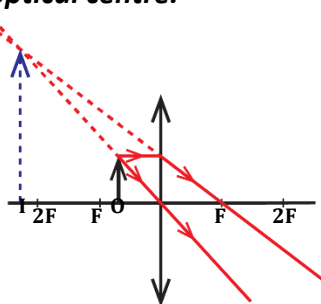

IMAGES FORMED BY CONCAVE (DIVERGING) LENSES

For all positions of the object, the image formed by a concave lens is always virtual, upright and diminished.

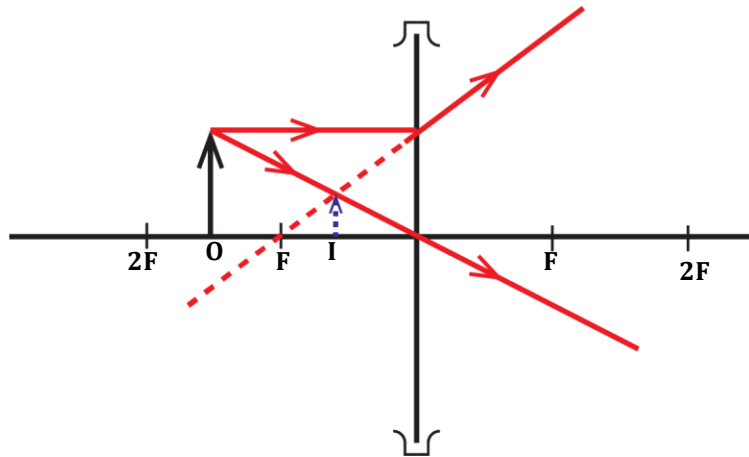

CONSTRUCTION OF ACCURATE RAY DIAGRAMS ON A GRAPH PAPER

Steps taken:

- ❖ Draw a horizontal line which acts as the principal axis.
- ❖ Choose a suitable scale for the object and its position depending on the given distances.
- ❖ Measure focal length, f and mark positions F and $2F$ (**Recall: $2F = 2f$**)
- ❖ Use any two rules to draw ray diagrams.

Examples:

1. An object of height 4cm is placed at a distance of 60cm from a converging lens of focal length 20cm. Find by scale drawing the position, height and nature of the image.

Axis	Scale	Conversion
Vertical axis	1: 2cm	▪ <u>Height of object, O:</u> $\frac{4}{2} = 2cm$
Horizontal axis	1: 10cm	▪ <u>Focal length, f:</u> $\frac{20}{10} = 2cm$ ▪ <u>Object distance, U:</u> $\frac{60}{10} = 6cm$

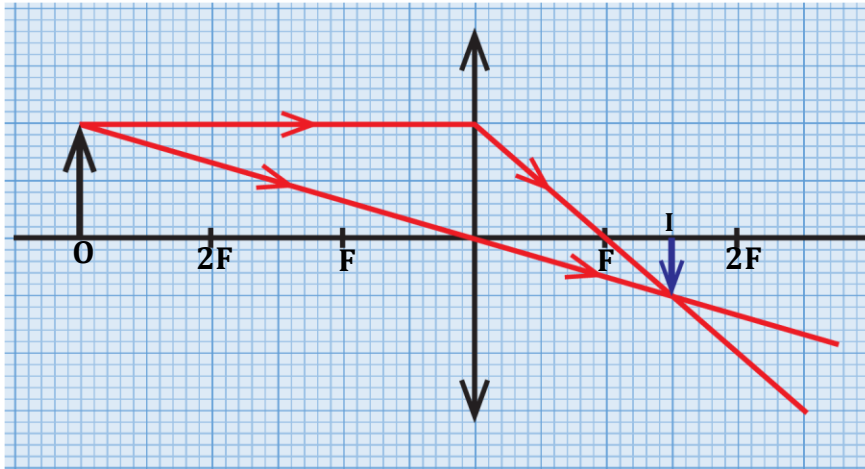

Image position, V

Hint: (3×10)
 $V = 30\text{cm}$

Nature of image

- *Inverted*
- *Diminished*
- *Real*

Size of image

Hint: (1×2)
 $h_i = 2\text{cm}$

2. An object of height 2cm is placed at a distance of 10cm from a converging lens of focal length 30cm. Find by scale drawing the position, the height and the nature of the image.

Axis	Scale	Conversion
Vertical axis	1: 1cm	<ul style="list-style-type: none"> ▪ <u>Height of object, O:</u> $\frac{2}{1} = 2\text{cm}$
Horizontal axis	1: 10cm	<ul style="list-style-type: none"> ▪ <u>Focal length, f:</u> $\frac{30}{10} = 3\text{cm}$ ▪ <u>Object distance, U:</u> $\frac{10}{10} = 1\text{cm}$

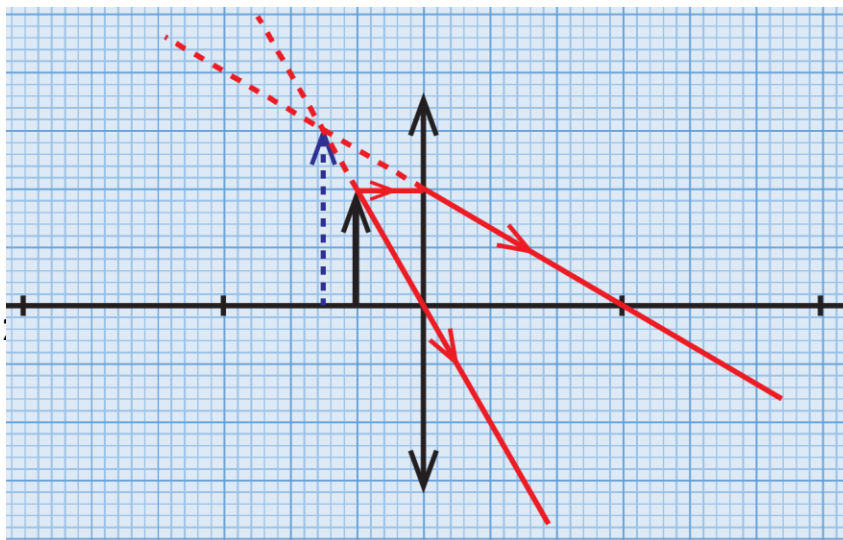

Image position, V

Hint: (1.5×10)
 $V = 15\text{cm}$

Nature of image

- *Upright*
- *Magnified*
- *Virtual*

Height of image

Hint: (3×1)
 $h_i = 3\text{cm}$

Magnification

$$M = \frac{v}{u} = \frac{15}{10}$$

$$M = 1.5$$

3. An object of height 10cm is placed at a distance of 60cm from a diverging lens of focal length 20cm. Find by accurate diagrams, the;
- Image position
 - Height of image
 - Nature of image
 - Magnification

Axis	Scale	Conversion
Vertical axis	1: 5cm	<ul style="list-style-type: none"> Height of object, O: $\frac{10}{5} = 2cm$
Horizontal axis	1: 10cm	<ul style="list-style-type: none"> Focal length, f: $\frac{20}{10} = 2cm$ Object distance, U: $\frac{60}{10} = 6cm$

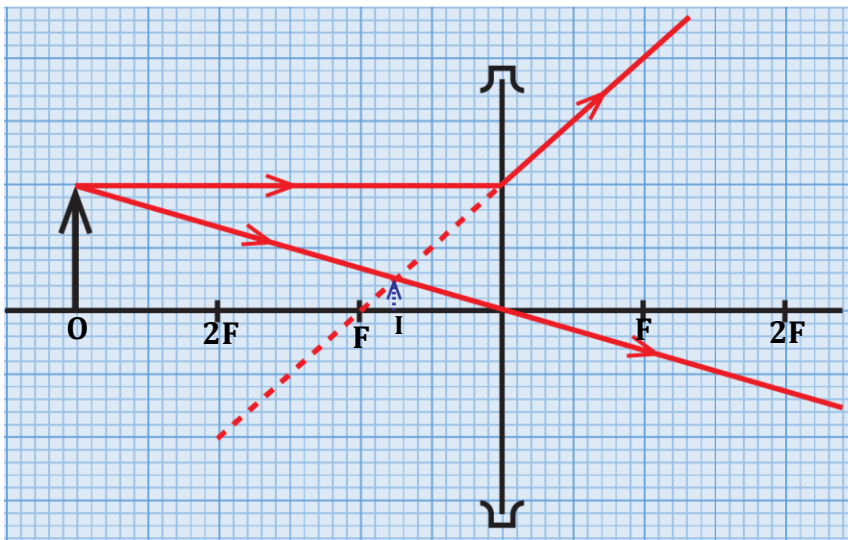

- Image position, V**
Hint: (1.5×10)
 $V = 15cm$
- Height of image**
Hint: (0.5×5)
 $h_i = 2.5cm$
- Nature of image**
 - Upright
 - Diminished
 - Virtual
- Magnification**

$$M = \frac{v}{u}$$

$$M = \frac{15}{60}$$

$$M = 0.25$$

4. An object 5cm tall placed in front of a converging lens forms an inverted image 10cm tall and 30cm from the lens. By construction, find the position of the object and focal length of the lens.

Axis	Scale	Conversion
Vertical axis	1: 5cm	<ul style="list-style-type: none"> ▪ <u>Height of object, O:</u> $\frac{5}{5} = 1cm$ ▪ <u>Height of image, I:</u> $\frac{10}{5} = 2cm$
Horizontal axis	1: 10cm	<ul style="list-style-type: none"> ▪ <u>Image distance, V:</u> $\frac{30}{10} = 3cm$

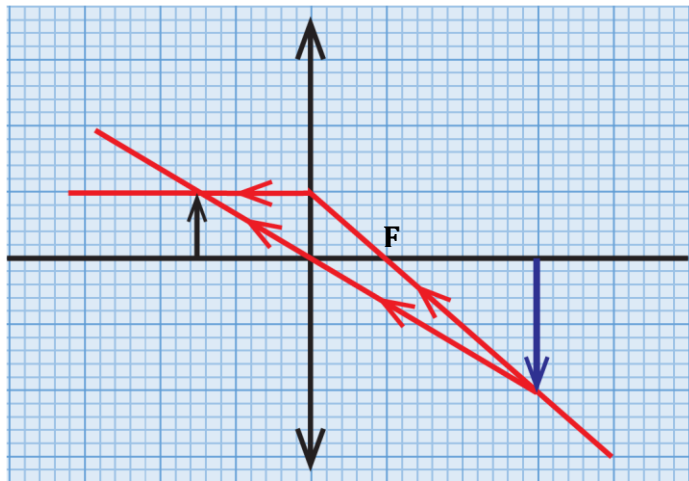

Object position, U

Hint: (1.5×10)

$U = 15cm$

Focal length, f

Hint: (1×10)

$f = 10cm$

Recall: Light rays are reversible

5. An object 32.5cm from a diverging lens of focal length 12cm. By scale drawing and using height of your own choice, find the position and nature of the image.

Let height of object be 10cm

Axis	Scale	Conversion
Vertical axis	1: 5cm	<ul style="list-style-type: none"> ▪ <u>Height of object, O:</u> $\frac{10}{5} = 2cm$
Horizontal axis	1: 5cm	<ul style="list-style-type: none"> ▪ <u>Focal length, f:</u> $\frac{12}{5} = 2.4cm$ ▪ <u>Object distance, U:</u> $\frac{32.5}{5} = 6.5cm$

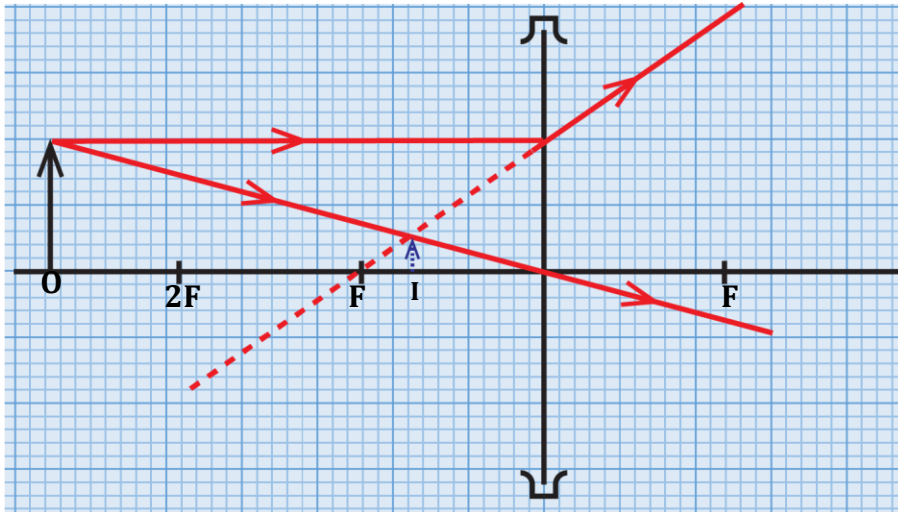

Image position, V

Hint: (1.75×5)

$V = 8.75\text{cm}$

Nature of image

- Upright
- Diminished
- Virtual

LENS FORMULA

The both formula for both converging and diverging lenses is given by;

$$\frac{1}{f} = \frac{1}{u} + \frac{1}{v}$$

where f = focal length

u = object distance

v = image distance

Sign convention;

It states that “**real**” is positive and “**virtual**” is negative.

Note:

When calculating using the lens formula;

- The focal length, image distance and object distance of a converging lens are positive.
- The focal length and image distance of a diverging lens are negative but the object distance remains positive.

Examples;

1. An object of height 10cm is placed at a distance of 60cm from a diverging lens of focal length 20cm. Find the position of the image and state its nature.

$$u = 60\text{cm}, v = ?, f = -20\text{cm}$$

Image position;

$$\frac{1}{f} = \frac{1}{u} + \frac{1}{v}$$

$$\begin{aligned} \frac{1}{-20} &= \frac{1}{60} + \frac{1}{v} \\ \frac{1}{-20} - \frac{1}{60} &= \frac{1}{v} \\ \frac{1}{v} &= \frac{-1}{15} \\ v &= -15\text{cm} \end{aligned}$$

The image is;

- Virtual (since V is negative)
- Upright and diminished (it is a diverging lens)

2. An object of height 4cm is placed at a distance of 60cm from a converging lens of focal length 30cm. Find the position and height of the image.

$$u = 60\text{cm}, v = ?, f = 30\text{cm}, h_o = 4\text{cm}$$

<u>Image position:</u>	$\frac{1}{30} = \frac{1}{60} + \frac{1}{v}$	$\frac{v}{u} = \frac{h_i}{h_o}$
	$\frac{1}{f} = \frac{1}{u} + \frac{1}{v}$	$\frac{60}{60} = \frac{h_i}{4}$
	$\frac{1}{30} - \frac{1}{60} = \frac{1}{v}$	$h_i = 4\text{cm}$
	$\frac{1}{v} = \frac{1}{60}$	
	$v = 60\text{cm}$	

POWER OF A LENS

Power of a lens is the reciprocal of its focal length in metres.

Its SI unit is Dioptres (**D**).

$$\text{Power of a lens} = \frac{1}{\text{focal length}(m)}$$

$$P = \frac{1}{f(m)}$$

Examples:

1. Calculate the power of a converging lens of focal length 10mm.

$f = 10\text{mm} = \frac{10}{1000} = 0.01\text{m}$	$P = \frac{1}{0.01}$
$P = \frac{1}{f}$	$P = 100\text{D}$

2. Calculate the power of a diverging lens of focal length 10cm.

$f = -10\text{cm} = \frac{-10}{100} = -0.1\text{m}$	$P = \frac{1}{-0.1}$
$P = \frac{1}{f}$	$P = -10\text{D}$

NOTE:

If two lenses are combined, we get their total power of combination.

Total power of combination = power of first lens + power of second lens

3. Two converging lenses of focal length 15cm and 20cm are placed in contact. Calculate the power of combination.

$f_1 = 15\text{cm} = \frac{15}{100} = 0.15\text{m}$	$P = P_1 + P_2$
$f_2 = 20\text{cm} = \frac{20}{100} = 0.2\text{m}$	$P = \frac{1}{f_1} + \frac{1}{f_2}$
	$P = \frac{1}{0.15} + \frac{1}{0.2}$
	$P = 11.67\text{D}$

4. A converging lens of focal length 20cm is placed in contact with a diverging lens of focal length 100mm. find the power of the combination.

$$f_1 = 20\text{cm} = \frac{20}{100} = 0.2\text{m}$$

$$f_2 = -100\text{mm} = \frac{-100}{1000} = -0.1\text{m}$$

$$P = P_1 + P_2$$

$$P = \frac{1}{f_1} + \frac{1}{f_2}$$

$$P = \frac{1}{0.2} + \frac{1}{-0.1}$$

$$P = -5D$$

METHODS OF DETERMINING FOCAL LENGTH OF A CONCAVE MIRROR

(Methods of determining radius of curvature of a concave mirror)

- (a) Using a distant object/approximate/rough method:

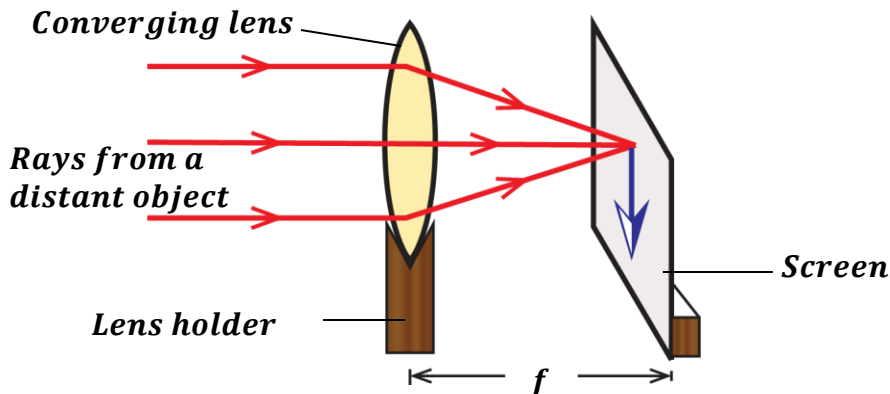

- The apparatus is arranged as shown above.
- Light from a distant object e.g. a window is focused onto the screen.
- The converging lens is moved to and fro until a sharp image of a distant object is obtained on the screen.
- The distance between the sharp image (screen) and the lens is measured and it is approximately equal to the focal length of the lens.

- (b) Using plane mirror method:

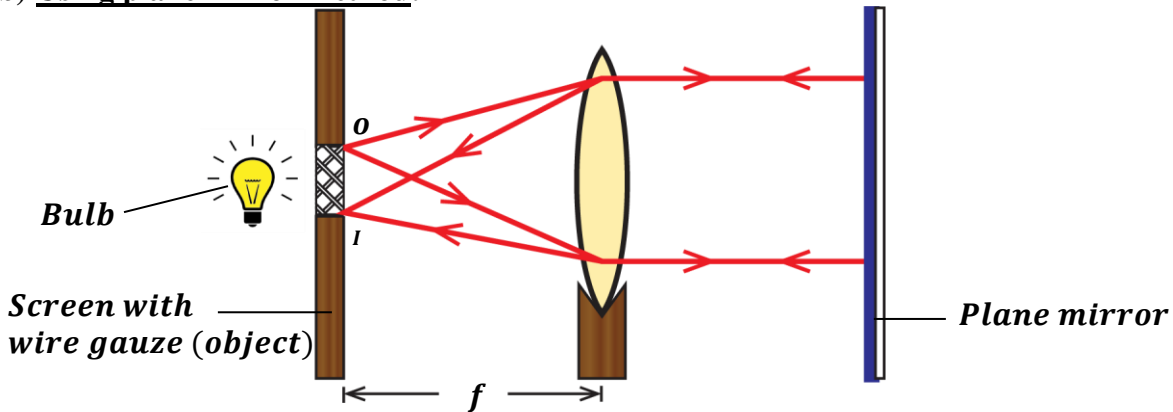

- An illuminated wire gauze is placed in front of the converging lens.
- A plane mirror is placed behind the lens to reflect back the light that passes through the lens.
- The converging lens is moved to and fro until a sharp image of the wire gauze is formed on the screen near the object. At this point the image and the object will be at the principal focus.
- The distance between the lens and the screen is measured and it is equal to the focal length, f of the converging lens.

(c) Using object and image distances (Lens formula method):

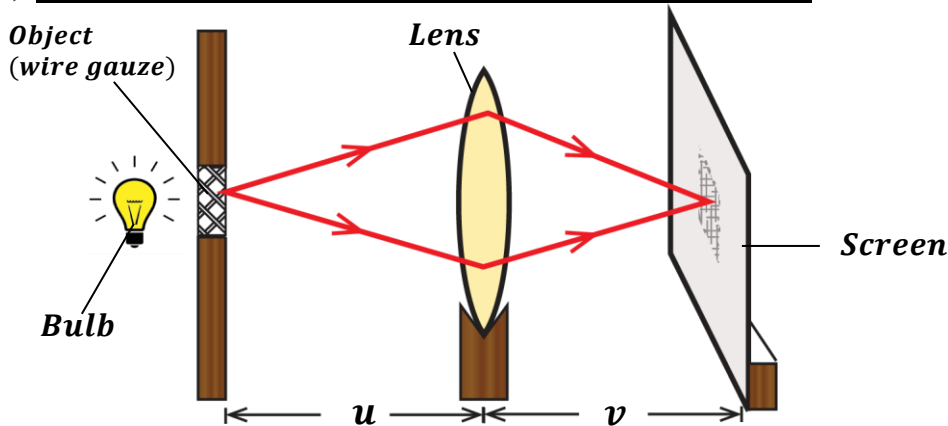

- The apparatus is arranged as shown above with the lens between the screen and the object.
- The lens is placed at a known distance, u from the wire gauze.
- The screen is moved to and fro until a clear image of the object is formed on it.
- The image distance, v is then measured and recorded.
- The experiment is repeated for different values of object distance, u and the corresponding values of image distance are obtained.
- The results are tabulated including values of $\frac{1}{u}$ and $\frac{1}{v}$.

u	v	$\frac{1}{u}$	$\frac{1}{v}$

- The focal length for all values is calculated from;

$$\frac{1}{f} = \frac{1}{u} + \frac{1}{v}$$
- The accurate focal length is obtained by getting the mean value of the calculated focal lengths.

APPLICATIONS OR USES OF LENSES

- The eye uses a lens to focus images on the retina.
- Lenses are used in spectacles to correct eye defects.
- Lenses are used in lens cameras.
- Lenses are used in projectors.
- Lenses are used in microscopes.

OPTICAL INSTRUMENTS

(Applications of lenses)

Optical instruments help us to see near and far objects clearly.

They include;

- Slide projectors
- Telescopes
- Lens cameras
- Periscopes
- Human eye
- Microscopes

SLIDE PROJECTORS

The projector is used to project the image of a slide onto the screen. It forms a real image.

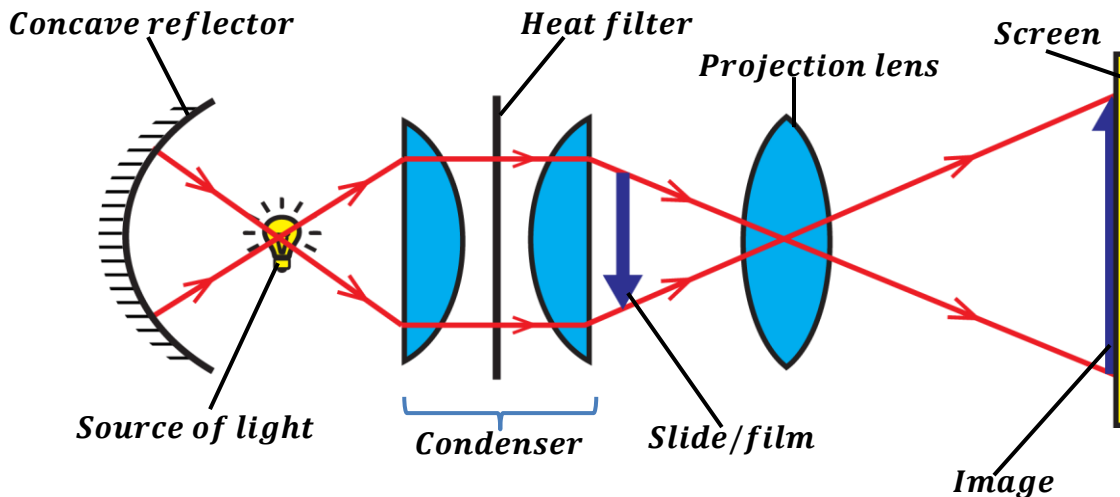

Functions of the parts of the projector:

Source of light:

It provides a powerful beam of light which illuminates the whole system.

Concave reflector:

It reflects back light rays that would have been wasted.

Condenser:

It is made up of two plano-convex lenses which converge and concentrate light onto the slide.

Slide / film:

It acts as the object whose image is to be projected.

Projection lens:

It magnifies the image of the slide on the screen.

Screen:

This is where the real image of the slide is formed.

Heat filter:

It absorbs any heat from the source which would melt the slide.

Examples:

1. A projection lens is used to produce a sharp image of an object when the object and the screen are 160cm apart. If the linear magnification is 7, calculate the focal length of the lens used.

$$\begin{array}{l}
 M = 7, \quad u + v = 160\text{cm} \Rightarrow v = 160 - u \\
 M = \frac{v}{u} \\
 7 = \frac{160 - u}{u} \\
 7u + u = 160 \\
 u = \frac{160}{8} \\
 u = 20\text{cm} \\
 v = 160 - 20 \\
 v = 140\text{cm}
 \end{array}
 \quad \left| \quad
 \begin{array}{l}
 \frac{1}{f} = \frac{1}{u} + \frac{1}{v} \\
 \frac{1}{f} = \frac{1}{20} + \frac{1}{140} \\
 \frac{1}{f} = \frac{2}{35} \\
 f = \frac{35}{2} \\
 f = 17.5\text{cm}
 \end{array}$$

2. A slide projector using slide 5cm by 5cm produces a picture of 3cm by 3cm on the screen at a distance of 24cm from the projection lens. How far from the lens must the slide be?

$$\begin{array}{l}
 h_o = 5\text{cm} \quad h_i = 3\text{cm} \quad v = 24\text{cm} \\
 \frac{h_i}{h_o} = \frac{v}{u} \\
 \frac{3}{5} = \frac{24}{u} \\
 u = \frac{24 \times 5}{3} \\
 u = 40\text{cm}
 \end{array}$$

LENS CAMERA

It consists of a light-tight box with a convex lens at the front side. It has a light sensitive film at the back on which a real, inverted and diminished image. The inner surface is painted black to prevent the reflection of stray rays of light which would blur the image.

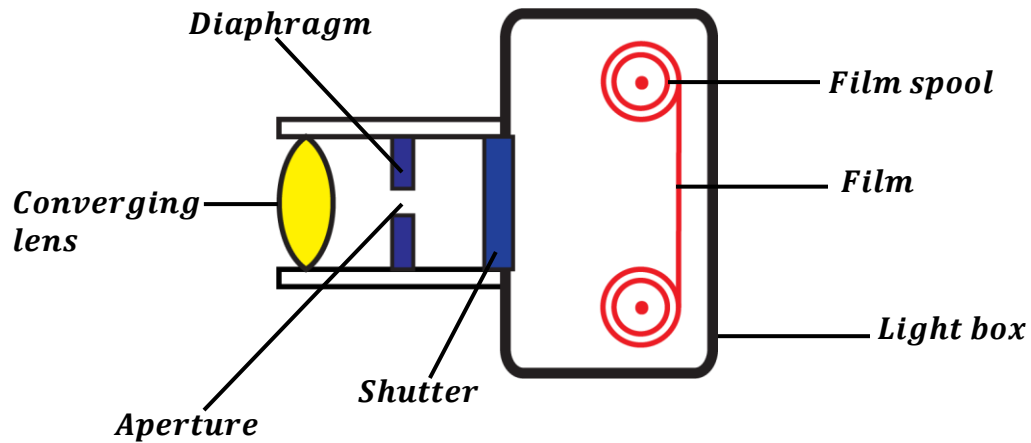

Functions of the parts of the lens camera:

Converging lens:

It focuses the image of the object on the film.

Diaphragm:

It controls the size of the aperture thus controlling the amount of light entering the camera. The brightness of the image depends on the amount of light entering the camera.

Shutter:

It controls the amount of light reaching the film.

Film:

It is a light-sensitive part where a real, inverted and diminished image is formed.

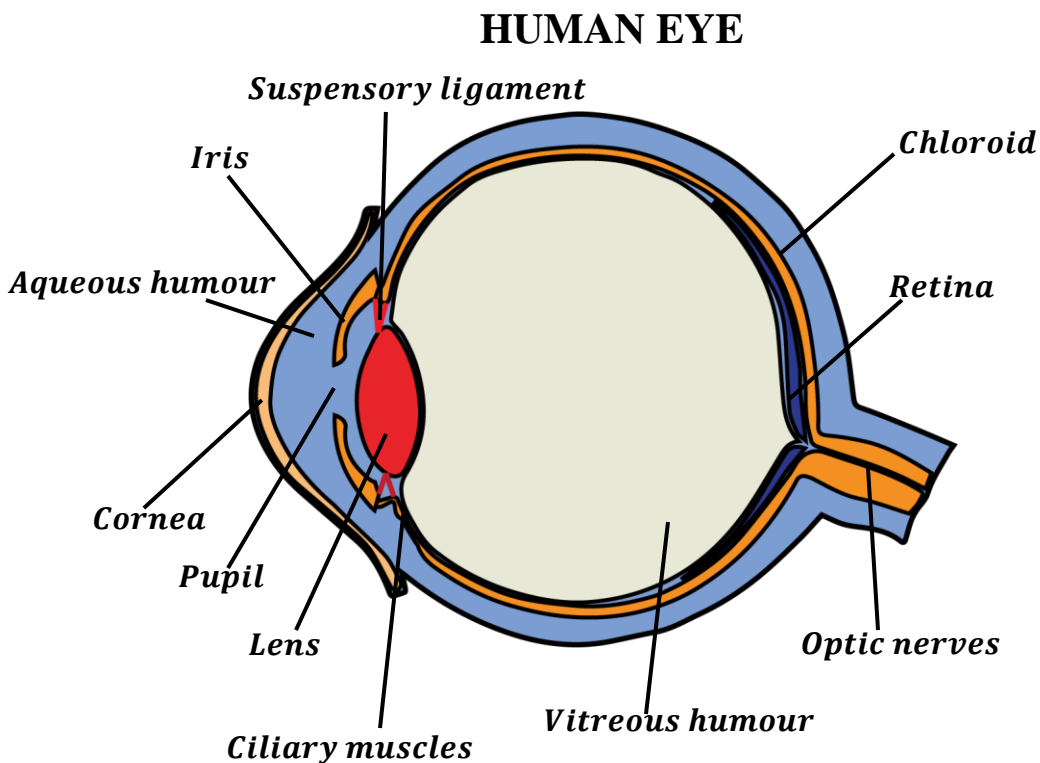

Light enters the eye through the cornea. The eye lens focusses the image of the object onto the retina.

The retina is sensitive to light and sends messages to the brain through the optic nerves.

Light entering the eye is controlled by the iris.

The lens changes its size so as to focus images of far and near objects on the retina and this is referred to as accommodation.

Functions of the parts of the eye:

Lens:

The convex lens changes in size so as to focus light onto the retina.

Ciliary muscle:

This changes the focal length of the eye lens by changing its size.

Iris:

It controls the amount of light entering the eye by regulating the size of the pupil.

Retina:

This is where the image is formed.

Optic nerves:

They transmit signals of the image from the retina to the brain for interpretation.

NOTE:

- Eye brows stop sweat from running into the eyes.
- Eye lashes help to stop dust blowing into the eye.
- Blinking of the eye prevents dust and other particles from reaching the surface of the cornea.

Important definitions

Accommodation: This is the ability of the eye to change the focal length of its lens so as to focus images of near and far objects on the retina.

OR

This is the ability of the eye to focus images of near and far objects on the retina by changing the size of the eye lens.

Near point: This is the closest or nearest point at which an eye can have a clear vision/image.
For a normal eye, the near point is 25cm.

Far point: This is the most distant or furthest point at which the eye can have a clear vision/image.
For a normal eye, the far point is at infinity.

EYE DEFECTS AND THEIR CORRECTIONS

This is a situation where the eye is unable to focus images of near and far objects on the retina.

There are two common eye defects namely;

- Short sightedness (Myopia)
- Long sightedness (Hypermetropia)

SHORT SIGHTEDNESS (MYOPIA)

A short-sighted person can see nearby objects clearly but cannot see far objects clearly.

The images of the near objects are formed on the retina.

The images of far objects are formed in front of the retina because the eye ball is too long.

This causes a shorter focal length of the eye lens.

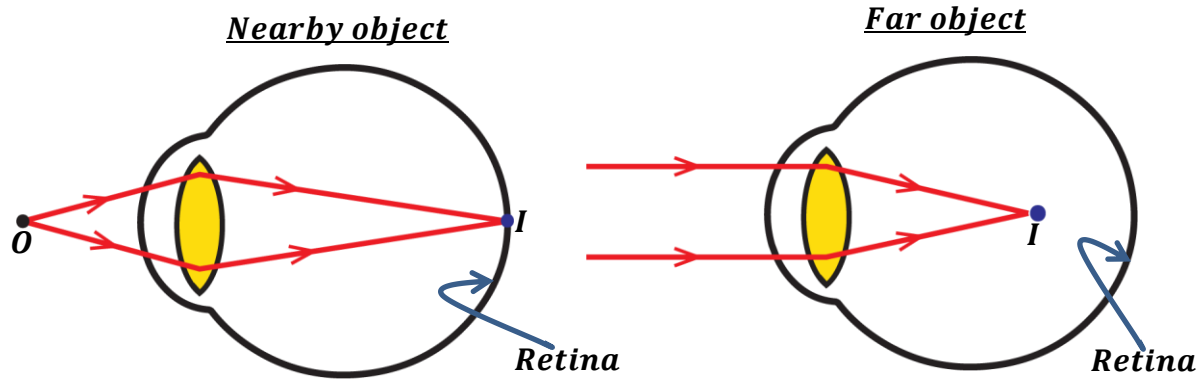

Correction of short sightedness:

It is corrected by wearing spectacles containing a diverging (concave) lens.

The diverging lens diverges the light rays from the far object before entering the eye and the convex lens of the eye converges the diverged rays onto the retina thus forming a clear image.

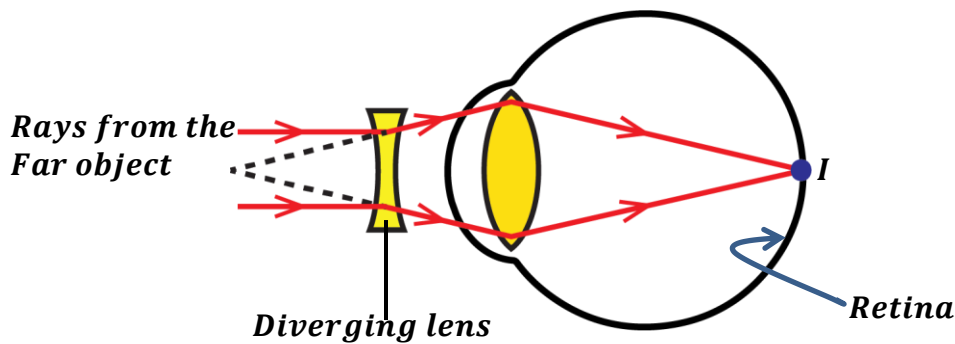

LONG SIGHTEDNESS (HYPERMETROPIA)

A long-sighted person can see far objects clearly but cannot see nearby objects clearly.

The images of the far objects are formed on the retina.

The images of nearby objects are formed behind the retina because the eye ball is too short.

This causes a longer focal length of the eye lens.

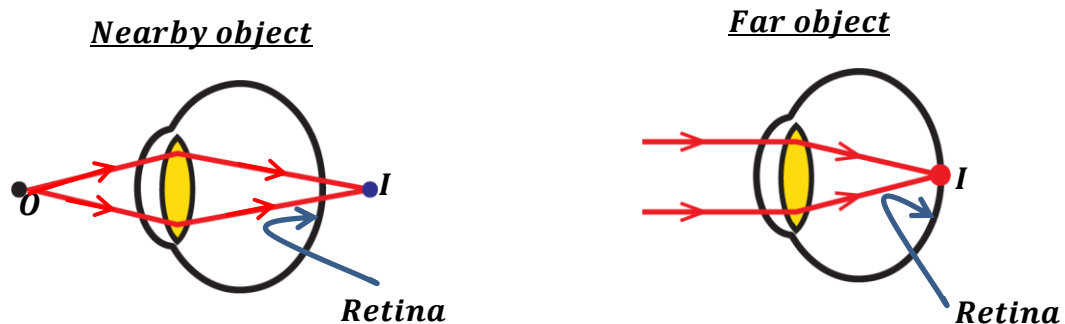

Correction of long sightedness:

It is corrected by wearing spectacles containing a converging (convex) lens.

The converging lens converges the light rays from the near object before entering the eye and the convex lens of the eye converges the converged rays onto the retina thus forming a clear image.

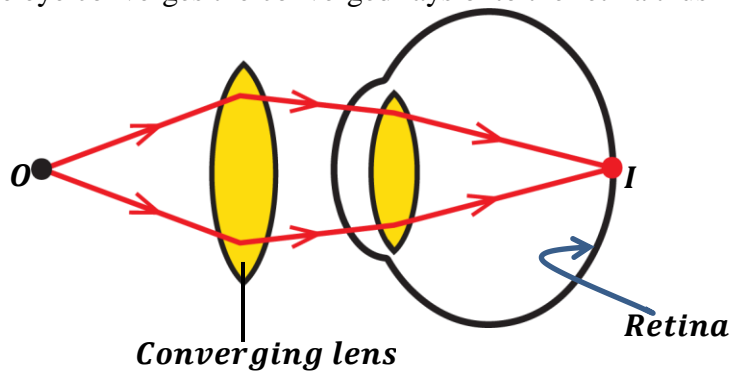

Astigmatism:

This is where light rays entering the eye fails to come to a single focus point. The person sees a distorted image. A person suffering from astigmatism faces eye strains and headaches after prolonged reading and watching televisions.

SIMILARITIES BETWEEN THE EYE AND THE CAMERA

- Both have a convex lens.
- Both form a real, inverted and diminished image.
- Both have a system which controls the amount of light entering i.e. Iris is to eye and Diaphragm is to camera.
- Both have a light sensitive part where images are formed i.e. retina is to eye and film is to camera.
- The camera is painted black inside and the eye is impregnated with a black pigment called choroid.

DIFFERENCES BETWEEN THE EYE AND CAMERA

Human eye	Lens camera
<ul style="list-style-type: none"> • The eye lens is biological (natural). • The eye lens has a changing focal length. • The distance between the eye lens and retina is fixed. • Forms an image on the retina. • Amount of light entering the eye is controlled by the iris. 	<ul style="list-style-type: none"> • The camera lens is artificial. • The camera lens has a fixed focal length. • The distance between the camera lens is adjustable. • Forms an image on the film. • Amount of light entering the camera is controlled by the diaphragm.

COLOURS AND DISPERSION OF LIGHT

Colours of objects depend on the colour of light which reaches our eyes.

It is proved that white light is made up of a mixture (band) of seven colours i.e. Red, Orange, Yellow, Green, Blue, Indigo and Violet. (ROYGBIV)

This band of colours in white light is referred to as a **spectrum**.

Definition;

A **spectrum** is a band of seven colours that form white light.

DISPERSION OF WHITE LIGHT:

❖ **Dispersion** is the splitting of white light into its constituent colours.

When white light is passed into a prism, it is deviated and separated into seven colours. This is because the refractive index for a prism is different for each colour.

Therefore, each colour moves at a different speed.

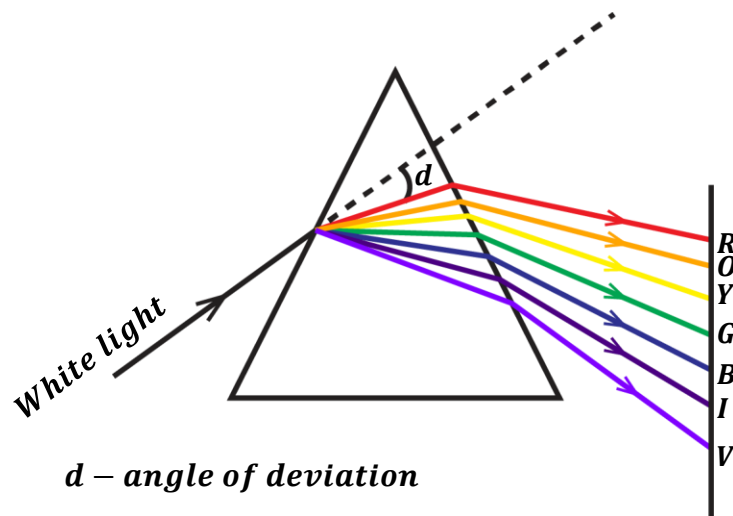

- Red colour which has the least refractive index is deviated least.
- Violet colour which has the highest refractive index is deviated most.

PURE SPECTRUM

A **pure spectrum** is a spectrum in which the colours do not overlap (i.e. one colour not mixing with the another colour)

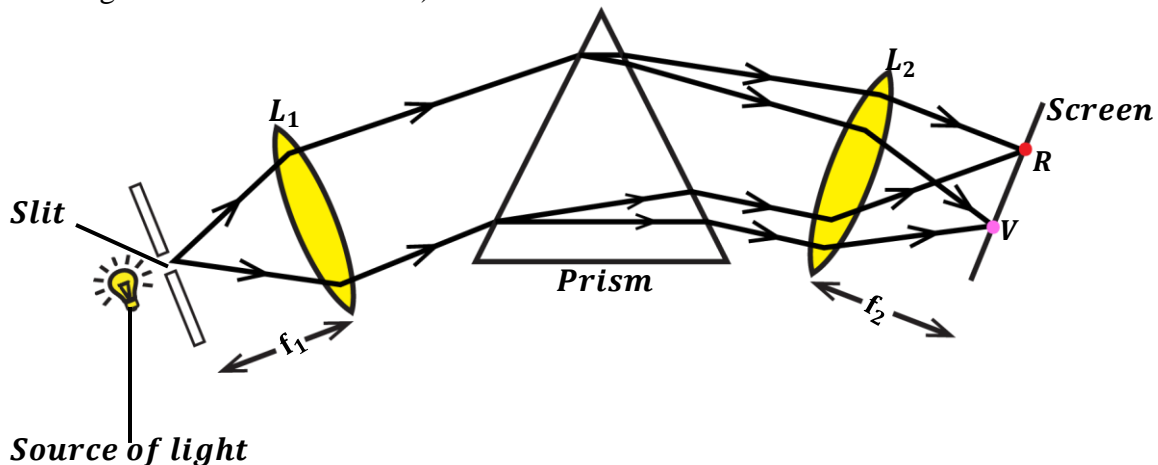

- An illuminated slit is placed at the principle focus of the first converging lens, L_1 .
- The converging lens, L_1 converges a parallel beam of light onto the prism.
- Dispersion of light occurs at the prism thus separating the light into different colours.
- A second converging lens, L_2 is placed at the other side of the prism.
- A screen is then placed at the principle focus of the second converging lens, L_2 .
- The second converging lens, L_2 focus each constituent colour of white light onto the screen at different points without overlapping hence forming a pure spectrum.

NOTE:

- ❖ The first lens, L_1 helps to produce a parallel beam of light from the source of light (i.e. rays from the principal focus are refracted as parallel)
- ❖ The slit should be made narrow to reduce the overlapping of colours.
- ❖ The combination of the slit and first lens is called a collimator (to collimate means to make it parallel)

FORMATION OF A RAIN BOW

- When white light from the sun is incident on a rain drop in the atmosphere, it undergoes refraction and then dispersed into different colours of the spectrum.
- The spectrum is internally reflected back in the opposite direction from where it came from.
- The spectrum finally emerges out (refracts out) and this is viewed as a rain bow.

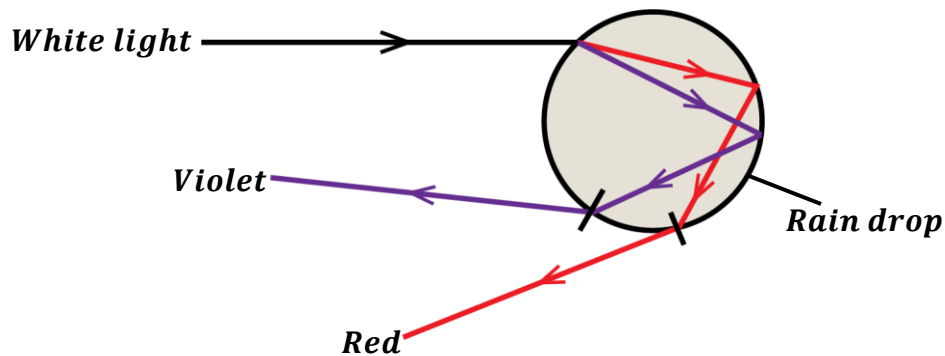

COLOURS

The colour of an object depends on the colour falling on it and the colour the object reflects. Therefore, an object absorbs all other colours and reflects the colour we see.

Examples

- ❖ A green leaf appears green in white light (day light) because the leaf absorbs all other colours in white light and reflects only green.
- ❖ White object appears white in white light because it absorbs no colour and reflects all the colours in white light.
- ❖ A blue shirt appear black in a dark room because there is no light falling on it in a dark hence it reflects nothing.

TYPES OF COLOURS:

There are three types of colours namely;

- Primary colours
- Secondary colours
- Complementary colours

Primary colours:

These are colours which cannot be obtained by mixing any other colours. Examples include; Red, Blue, and Green (**RGB**)

Secondary colours:

These are colours which are obtained by mixing any two primary colours. Examples include;

$$\text{Yellow} = \text{Red} + \text{Green}$$

$$\text{Cyan} = \text{Blue} + \text{Green}$$

$$\text{Magenta} = \text{Red} + \text{Blue}$$

Complementary colours:

These are colours which produce white light when mixed together. Examples include;

$$\text{Blue} + \text{Yellow} = \text{White}$$

$$\text{Red} + \text{Cyan} = \text{White}$$

$$\text{Green} + \text{Magenta} = \text{White}$$

Note: When all the three primary colours are mixed together, white light is produced.

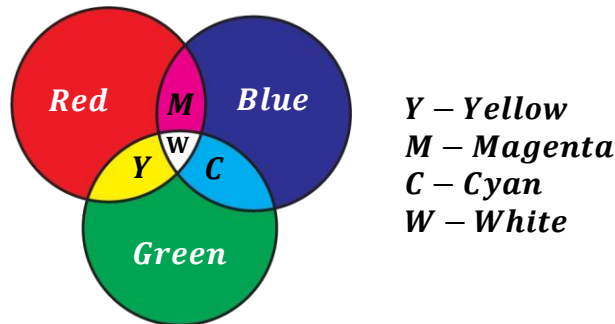

COLOUR FILTERS:

A colour filter is a transparent coloured material which allows light of its own colour type to pass through it and absorbs other colours.

That's to say;

- Green filter allows only green light to pass through it.
- White filter allows red, green and blue light to pass through it.
- Cyan filter allows only blue and green light to pass through it.
- Magenta filter allows only red and blue light to pass through it

ETC

Examples:

- ❖ When white light is incident on a red filter, it allows only red light to pass through it (transmits) and absorbs blue and green light.

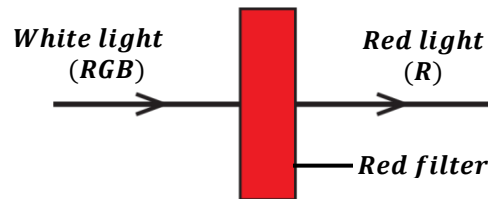

- ❖ A green filter allows only green light to pass through it and absorbs other colours when placed in white light.

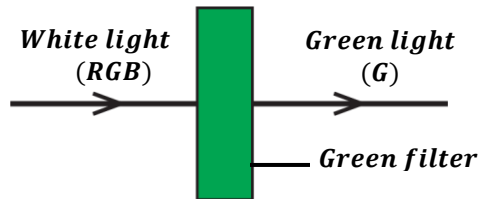

- ❖ When yellow light is incident on a blue filter, no colour is allowed to pass through it. Therefore, red and green light is absorbed hence we see black.

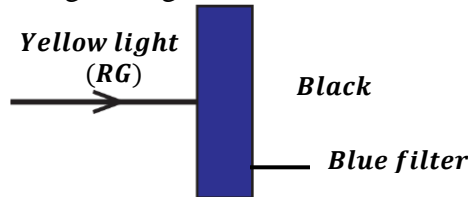

- ❖ When magenta light is incident on a cyan filter, only blue light will pass through it but red and green lights are absorbed.

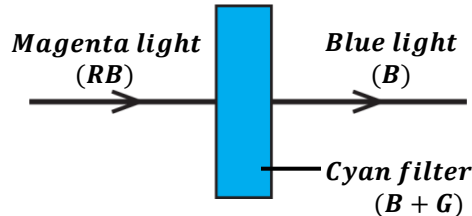

- ❖ When white light is incident on the cyan filter and then magenta filter; cyan filter allows only green and blue light to pass through it and then the magenta filter allows only blue light to pass through it.

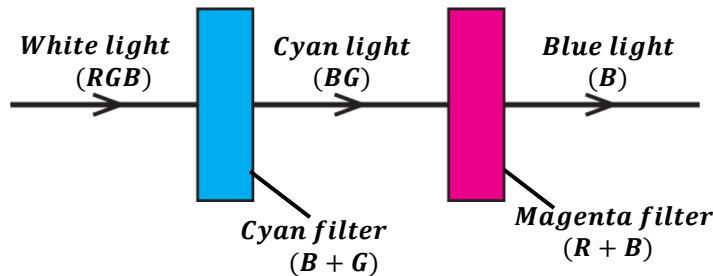

Further examples:

1. A girl wearing a red dress with white strips passes under green light. What will be the colour of her dress under green light?

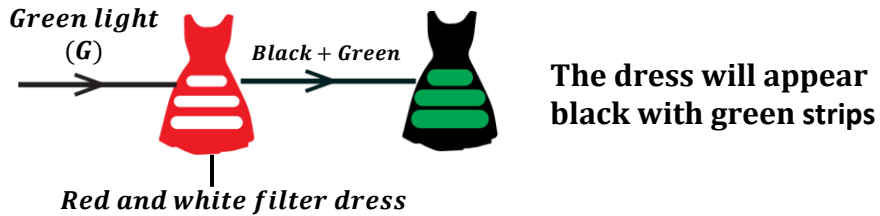

2. A house is painted green and blue. What will be the colour of the house when viewed under magenta light?

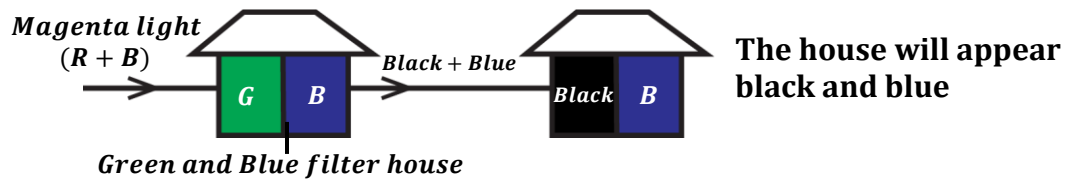

3. What colour will be observed when a girl wearing yellow dress with blue dots dances in a disco hall with green light?

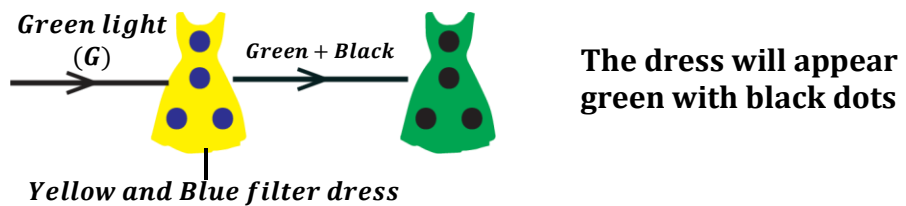

EXERCISE:

1. What colour should filter X have so that red light is seen on the screen.

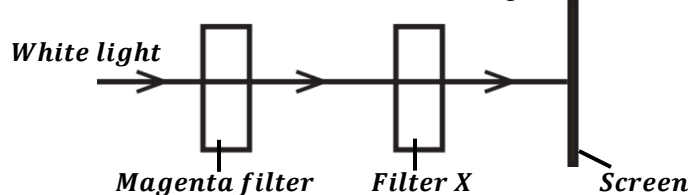

2. Explain the appearance of a student wearing a green sweater in a disco hall with yellow light.
3. Explain why an object illuminated by white light appears black.
4. State why most car registration numbers plates are printed black on a yellow background.

EXAMINATION QUESTIONS

- 1.a) What is meant by focal length of a lens
b) Where should an object be placed in front of a converging lens in order to obtain
i) Diminished real image
ii) A real image, same size as the object
iii) A magnified real image
iv) A magnified virtual image
c) An object 4cm high is placed perpendicularly on the principal axis 10cm away from a converging lens of focal length 15cm. With the aid of a ray diagram, determine nature, position and magnification of the image formed

Ans: 30cm, 3

- d) Mention two applications of the image formed
2.a) Define the following
i) Critical angle ii) Total internal reflection
b) Explain briefly why the sky appears blue
c) State two applications of a concave mirror
d) i) An object 8cm high is placed perpendicularly on the axis and 12cm away from a concave mirror. With the aid of a ray diagram, find the focal length of the mirror if the height of the image formed is 2cm

Ans: 2.4cm

- ii) State the nature of the image formed in (i) above
3.a) Explain dispersion as applied to light
b) i) What is a pure spectrum
ii) With the aid of a labeled diagram, describe briefly how a pure spectrum is produced
c) i) Distinguish between a primary and a secondary colour
ii) The figure below shows colours mixed by addition. Name the colours represented by letters labeled A, B, C and D

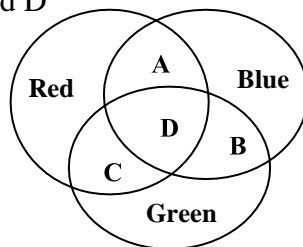

- d) State the colour of a yellow dress in green light
4.a) Define the following as applied to a concave mirror
i) Centre of curvature
ii) Principal axis
b) State and explain one application of
i) Concave mirror ii) Convex mirror
c) Describe an experiment to measure the focal length of a concave mirror
d) An object of height 1cm is placed 15cm in front of a concave mirror of focal length 10cm. If the object is perpendicular to the principal axis, find by construction the position, the size and nature of the image.

Ans: 30cm, 2cm

5. a) The diagram below shows a ray of yellow light incident at an angle of 50° on one side of an equilateral triangular glass prism of refractive index 1.52

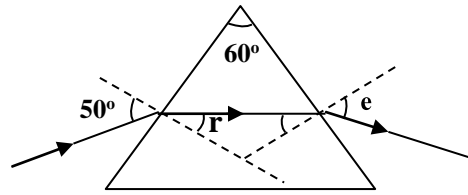

- i) Calculate the angles marked r and e

Ans: $r = 30.3^\circ$, $e = 48.9^\circ$

- ii) State and explain what would be observed if the ray above were of white light
 b) Explain, with the aid of a diagram, why the writing on a piece of paper placed under a glass block appears raised when observed from above
 c) State
 i) The conditions necessary for total internal reflection to occur
 ii) One application of total internal reflection
 6. a) i) State the laws of refraction of light
 ii) Describe an experiment to verify the laws of refraction of light
 b) An object 5cm tall placed in front of a converging lens, forms an inverted image twice as tall as the object and 30cm from the lens. By construction, find the position of the object, the focal length and power of the lens

Ans: 15cm, 10cm, 10D

- c) A ray of light is incident on glass from air at an angle of 42° . If the refractive index of glass is 1.41, find the angle of refraction

Ans: 28.3°

7. a) i) State the laws of reflection of light
 ii) Describe an experiment to verify the laws of reflection of light
 b) i) Define the term critical angle
 ii) A ray of light moving from water to air at an angle of incidence of 48.6° has the angle of refraction of 90° . Calculate the refractive index of water

Ans: 1.33

- c) Distinguish between primary and secondary colours
 d) White light is incident on two colour filters in the diagram below

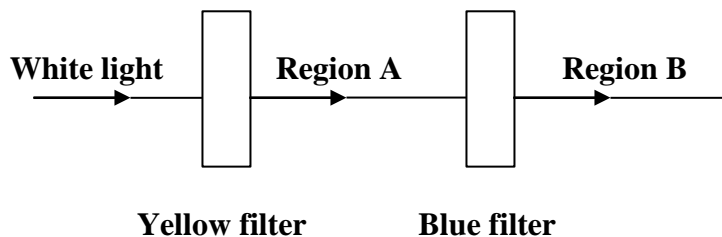

- i) State the colours that will be observed in regions A and B
 ii) Explain the observation in (d) (i) above
 8. a) Explain the term virtual image as applied to optics
 b) With aid of a ray diagram, explain why a convex mirror is used as a driving mirror

- c) An object is placed 15cm in front of a concave mirror. An upright image of magnification four is produced. By graphical method, determine the
- Nature of the image
 - Focal length of the mirror
 - Distance of the image from the mirror

Ans: ii) 12cm iii) 60cm

- d) Name two applications of a concave mirror

9. a) Explain the following terms as applied to a thin converging lens

- Principal focus
- Focal length
- Power

- b) An object is placed at right angles to the principal axis of a thin converging lens of focal length 10cm. A real image of height 5cm is formed at 30cm from the lens. Find by construction the position and height of the object.

Ans: 15cm, 2.5cm

- c) With the aid of a ray diagram show how a converging lens can be used as a magnifying glass

10. a) With the aid of a diagram, explain briefly how a pure spectrum may be produced

- What are primary colours? Name them
- Explain briefly what happens when white light falls on a green body

- c) With the aid of a labeled diagram, describe how a lens camera works

11. a) Explain the phenomenon of dispersion as applied to white light

- Draw a ray diagram to show the dispersion of white light by a glass prism
- Distinguish between secondary and primary colours. Give one example of each
- Name the colour that would be obtained when the following coloured lights are mixed
 - Green and red
 - Cyan and red

- e) Explain why an object illuminated by white light appears

- Coloured
- Black

12. a) Describe a simple method of measuring the refractive index of glass in form a block

- Explain, with the aid of a diagram, the term critical angle
- Light of the same wave length is incident at an angle i on glass prism. The light is refracted and follows the path shown in the figure below

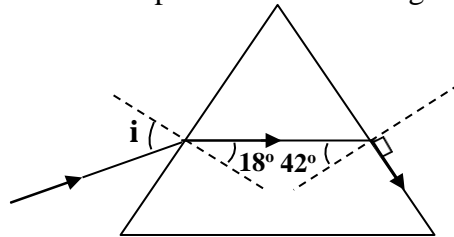

Find the refractive index of glass and the angle of incidence, i

Ans: $n = 1.49$, $i = 27.4^\circ$

13. a) Define

- The principal focus of a converging lens
- A virtual image

- b) With the aid of a labeled diagram, describe a simple to determine the focal length of a

converging lens

- c) An object of height 4cm is placed perpendicularly on the principal axis at a distance of 45cm from a converging lens of focal length 15cm. By graphical construction, determine
- The position of the image
 - The magnification

Ans: i) 22.5cm, 0.5

d) Give one use of converging lenses

14. a) i) Describe a simple experiment to show that light travels in a straight line
- An object 3cm high is placed at right angle to the principal axis of a concave mirror of focal length 7.5cm. If the object is 30cm from the pole of the mirror, construct a ray diagram to obtain the position and size of the image formed
 - State two applications of a concave mirror

Ans: ii) 10cm, 1cm

b) i) State laws of refraction of light

- Light of the same wavelength is incident from air on glass of refractive index 1.5. If the angle of incidence is 60° , find the angle of refraction

Ans: ii) 35.3°

15. a) Describe an experiment to demonstrate the laws of reflection of light

b) With the aid of a diagram illustrate how shadows are formed when an opaque object is placed between an extended source of light and the screen

c) An object 10cm high is placed at a distance of 15cm from a convex mirror of focal length 30cm

- Draw a ray diagram to locate the position of the image
- Calculate the magnification

Ans: i) 10cm

ii) 0.67

d) Give reasons for use of convex mirrors in vehicles