

A Holistic Approach to A-Level

SUBSIDIARY MATHEMATICS

Cawuma Fahad

First edition

$$= 1 - \frac{6\sum d^2}{n(n^2-1)} \quad x = \frac{-b \pm \sqrt{b^2 - 4ac}}{2a}$$

$$\sigma = \sqrt{\frac{\sum fx^2}{\sum f} - \left(\frac{\sum fx}{\sum f}\right)^2}$$

$$b = |a||b|\cos \theta \quad F = ma$$

REVISED BY;

LUBWAMA HAMZA

GOMBE S.S MATH DEPARTMENT

CONTENTS

PREFACE	(ii)
ACKNOWLEDGEMENT	(iii)
DEDICATION	(vii)

PART I: PURE MATHEMATICS

✓ CHAPTER ONE: LOGARITHMS, SURDS AND INDICES	1 - 10
Powers as indices, Laws of indices, Simplifying expressions, equations that require use of laws of indices, Logarithm as an index, Laws of logarithms, Simplification of logarithmic expressions, Change of base, Simple equations involving indices and logarithms, Rational and Irrational numbers, Simplification of surds, Rationalisation of surds, Simple equations involving surds.	
CHAPTER TWO: POLYNOMIALS	11 - 15
Formation of polynomial, Order of a polynomial, Operations on polynomials (addition, subtraction, multiplication and Division), evaluation of a polynomial; Factorisation of polynomials up to degree 2, Solving a polynomial	
✓ CHAPTER THREE: QUADRATIC EQUATIONS	16 - 21
Methods of solving quadratic equations, factorisation and completing the square, Sum and product of roots of a quadratic equation, Formation of quadratic equations, Equations reducing to quadratics, Maximum and minimum values of the quadratic functions.	
✓ CHAPTER FOUR: SERIES	22 - 29
Arithmetic and geometrical progressions, The nth term of A.Ps and G.Ps, sum of A.P, sum of a G.P	
✗ CHAPTER FIVE: DIFFERENTIATION	30 - 43
Gradient of a curve at a point, Equation of the tangent to the curve at a point, Equation of the normal to the curve at a point, Maximum and minimum points, Curve sketching, velocity and acceleration, Derivatives of trigonometric functions.	
✓ CHAPTER SIX: MATRICES	44 - 51
Operations on matrices, Determinant of a 2×2 Matrix, Inverse of a 2×2 matrix, Solution of simultaneous equations using matrices and determinant, (Cramer's rule)	

142
143
(11/12/20)

VECTORS

*CHAPTER SEVEN: **INTEGRATION** 52 - 59
Vector notations, Displacement vectors, Position vectors, Addition and subtraction of vectors, Multiplication by a scalar Magnitude of a vector, Unit vectors, Parallel vectors, Equal vectors, Dot/Scalar product of two vectors, Angle between vectors, Perpendicular vectors.

CHAPTER EIGHT: **VECTORS** **INTEGRATION** 60 - 69
The reverse of differentiation, Indefinite integrals, Definite integrals, Area under a curve

CHAPTER NINE: **TRIGONOMETRY** 70 - 96
Trigonometric ratios, Special angles of 0° , 30° , 45° , 60° and 90° , Graphs of $\sin \theta$, $\cos \theta$ and $\tan \theta$, Trigonometric identities, Trigonometric expressions, Compound Angle Formulae, Double Angle Formulae, Proving simple identities, Solving simple trigonometric equations, Solution of Triangle, Sine rule, cosine rule, the area of any triangle

CHAPTER TEN: **DIFFERENTIAL EQUATIONS** 97 - 101
Concept of a differential Equation, Order of a differential equation, General solution and particular solution of a differential equation, First order differential equations with separable variables, Formation of differential equations of natural occurrences

PART II: PROBABILITY AND STATISTICS

*CHAPTER ELEVEN: **DESCRIPTIVE STATISTICS** 102 - 121
Discrete raw data continuous raw data, Un grouped data, Grouped data, Data presentation methods, Frequency tables, Histograms, Cumulative frequency graph (Ogive), Interpretation of statistical diagrams (Frequency tables, Histograms and Ogive), Mean, mode and median, Range, Quartiles/percentiles, Variance and standard deviation, Data analysis.

*CHAPTER TWELVE: **MOVING AVERAGES** 122 - 130
The cycle of the data, Even and odd moving totals, Odd and even moving averages, Graphs of moving averages

CHAPTER THIRTEEN: **INDEX NUMBERS**..... 131 - 140
Concept of Price indices (Price relatives), Unweighted price indices, weighted price index, Weighted Aggregate price index, Value index

*CHAPTER FOURTEEN: **SCATTER GRAPHS AND CORRELLATION**..... 141 - 154
Concept of correlation, Scatter diagrams, Line of best fit, Rank correlation coefficient, Applications of coefficient of correlation

✓ **CHAPTER FIFTEEN: THE PROBABILITY THEORY** 155 - 168
Terminologies in probability theory, Probability laws and notations in relation to set theory,
Probability situations, the conditional probability, Probability tree diagrams.

CHAPTER SIXTEEN: PERMUTATIONS AND COMBINATIONS 169 - 174
Arrangement of objects in a row, Concept of permutation, Factorial notation $n!$, Arranging
objects in a circular form or ring, Ways of selecting objects, Selection of any size r from a
group.

CHAPTER SEVENTEEN: RANDOM AND CONTINUOUS VARIABLES 175 - 188

Discrete random variables

Concept of discrete random Variable, Probability density function (p.d.f) of a discrete
random Variable, Properties of a p.d.f of a discrete random variable, Probability
distribution table, Expectation $E(X)$, Variance, $Var(X)$, and Standard deviation of a
discrete random variable, Mode.

Continuous random variables

Concept of continuous random variable, Continuous probability Function, Properties of a
Continuous random Variable, Expectation, variance and standard deviation of a
continuous random variable.

CHAPTER EIGHTEEN: BINOMIAL DISTRIBUTION 189 - 195

Concept of a binomial Distribution, Properties of a binomial Distribution, Binomial
notation, Binomial tables, Expectation, variance and Standard deviation

CHAPTER NINETEEN : NORMAL DISTRIBUTION 196 - 202

Concept of normal Distribution, Properties of normal Distribution, Standardization,
Standard normal tables.

PART III: MECHANICS

CHAPTER TWENTY: LINEAR MOTION..... 203 - 211

Distance, displacement, velocity, speed, average speed, acceleration, Displacement-time
graphs, Velocity-time graphs, Equations of linear motion, Numerical problems.

CHAPTER TWENTY ONE: RESULTANT AND COMPONENTS OF FORCES..... 212 - 217

Resultant of parallel forces, non-parallel forces, any number of forces, Components of a
force, Resultant of a number of forces.

CHAPTER TWENTY TWO: FRICTION 218 - 226

Concept of friction, Limiting equilibrium, Coefficient of friction, Friction on horizontal
and inclined planes.

CHAPTER TWENTY THREE: NEWTON'S LAWS OF MOTION.....	227 - 236
A body at rest, a body in motion, Connected bodies along horizontal and inclined planes.	
CHAPTER TWENTY FOUR: WORK, ENERGY AND POWER.....	237 - 243
Work done against gravity by a constant force, work done against friction, Principle of conservation of Energy, Power	
BINOMIAL AND NORMAL DISTRIBUTION TABLES	244 - 246
REFERENCES	247

Examination Format

There will be one paper of **2 hours 40 minutes**. The paper will consist of **Two sections**: Section A and Section B.

Section A will comprise short questions on Pure Mathematics, Statistics and Mechanics while Section B will comprise longer questions. Section A will consist of **eight (8)** compulsory questions. Candidates will be required to attempt all questions each carrying 5 marks. Section B will consist of **six (6)** questions of which candidates will be required to attempt any **four (4)** each carrying 15 marks.

In Section B, **Six (6)** questions will be set from Pure Mathematics, Mechanics and Probability and Statistics.

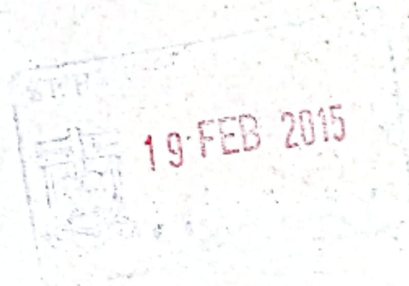

I DEDICATE THIS BOOK TO MY BELOVED PARENTS

CHAPTER 1: SURDS, LOGARITHMS AND INDICES**SURDS**

Expressions such as $\sqrt{4}, \sqrt{25}$ have exact numerical values i.e. $\sqrt{4} = 2, \sqrt{25} = 5$. However expressions such as $\sqrt{2}, \sqrt{3}, \sqrt{5} \dots$ can not be written numerically as exact quantities i.e. $\sqrt{2} = 1.414$ and $\sqrt{3} = 1.732$. Such numbers are called irrational and it's often more convenient to leave them in their form i.e. $\sqrt{2}, \sqrt{3}, \sqrt{5} \dots$ hence called **surds**.

Examples:

1. Write the following as the simplest possible surds

(i) $\sqrt{8}$ (ii) $\sqrt{12}$ (iii) $\sqrt{50}$ (iv) $\sqrt{48}$

Solution

(i) $\sqrt{8} = \sqrt{2 \times 4} = \sqrt{4} \times \sqrt{2} = 2\sqrt{2}$

(ii) $\sqrt{12} = \sqrt{4 \times 3} = \sqrt{4} \times \sqrt{3} = 2\sqrt{3}$

(iii) $\sqrt{50} = \sqrt{25 \times 2} = \sqrt{25} \times \sqrt{2} = 5\sqrt{2}$

(iv) $\sqrt{48} = \sqrt{16 \times 3} = \sqrt{16} \times \sqrt{3} = 4\sqrt{3}$

2. Simplify; $\sqrt{75} + \sqrt{108} + \sqrt{27}$

Solution

$$\begin{aligned} \sqrt{75} + \sqrt{108} + \sqrt{27} &= \sqrt{25 \times 3} + \sqrt{36 \times 3} + \sqrt{9 \times 3} \\ &= \sqrt{25} \times \sqrt{3} + \sqrt{36} \times \sqrt{3} + \sqrt{9} \times \sqrt{3} \\ &= 5\sqrt{3} + 6\sqrt{3} + 3\sqrt{3} \\ &= 14\sqrt{3} \end{aligned}$$

3. Expand and simplify

(a) $(3 - 3\sqrt{3})(3 + 2\sqrt{3})$

(b) $(5 - 2\sqrt{7})(5 + 2\sqrt{7})$

Solution:

(a) $(3 - 3\sqrt{3})(3 + 2\sqrt{3}) = 9 - 9\sqrt{3} + 6\sqrt{3} - 6(\sqrt{3})^2$
 $= 9 - 3\sqrt{3} - 6 \times 3$
 $= -9 - 3\sqrt{3}$

(b) $(5 - 2\sqrt{7})(5 + 2\sqrt{7}) = 25 - 10\sqrt{7} + 10\sqrt{7} - 4(\sqrt{7})^2 = 25 - 4 \times 7 = 25 - 28 = -3$

4. Rationalize the denominator of $\frac{3}{\sqrt{2}}$

Solution

Multiply numerator and denominator by $\sqrt{2}$

$$\frac{3}{\sqrt{2}} = \frac{3}{\sqrt{2}} \times \frac{\sqrt{2}}{\sqrt{2}} = \frac{3\sqrt{2}}{2}$$

5. Express $\frac{\sqrt{2}}{2\sqrt{3}}$ in the form $\sqrt{\frac{a}{b}}$ where a and b are real numbers.

Solution

$$\frac{\sqrt{2}}{2\sqrt{3}} = \frac{\sqrt{2}}{\sqrt{4} \times \sqrt{3}} = \frac{\sqrt{2}}{\sqrt{12}} = \sqrt{\frac{2}{12}} = \sqrt{\frac{1}{6}}$$

Alternatively;

$$\frac{\sqrt{2}}{2\sqrt{3}} = \frac{\sqrt{2}}{2\sqrt{3}} \times \frac{\sqrt{3}}{\sqrt{3}} = \frac{\sqrt{6}}{6} = \frac{\sqrt{6}}{\sqrt{36}} = \sqrt{\frac{6}{36}} = \sqrt{\frac{1}{6}}$$

6. Rationalize the denominator of $\frac{3-\sqrt{5}}{1+3\sqrt{5}}$

Solution

Multiply numerator and denominator by the denominator with sign of $3\sqrt{5}$ changed (conjugate of the denominator)

$$\begin{aligned} \frac{3-\sqrt{5}}{1+3\sqrt{5}} &= \frac{3-\sqrt{5}}{1+3\sqrt{5}} \times \frac{1-3\sqrt{5}}{1-3\sqrt{5}} \\ &= \frac{(3-\sqrt{5})(1-3\sqrt{5})}{(1+3\sqrt{5})(1-3\sqrt{5})} \\ &= \frac{18-10\sqrt{5}}{1^2-(3\sqrt{5})^2} \\ &= \frac{9-5\sqrt{5}}{-22} = \frac{5\sqrt{5}-9}{22} \end{aligned}$$

7. Express $\frac{2\sqrt{3}+3\sqrt{2}}{2\sqrt{3}-3\sqrt{2}}$ in the form $a + b\sqrt{c}$

Solution

$$\begin{aligned} \frac{2\sqrt{3}+3\sqrt{2}}{2\sqrt{3}-3\sqrt{2}} &= \frac{(2\sqrt{3}+3\sqrt{2})(2\sqrt{3}+3\sqrt{2})}{(2\sqrt{3}-3\sqrt{2})(2\sqrt{3}+3\sqrt{2})} \\ &= \frac{2\sqrt{3} \times 2\sqrt{3} + 2\sqrt{3} \times 3\sqrt{2} + 3\sqrt{2} \times 2\sqrt{3} + 3\sqrt{2} \times 3\sqrt{2}}{2\sqrt{3} \times 2\sqrt{3} + 2\sqrt{3} \times 3\sqrt{2} - 3\sqrt{2} \times 2\sqrt{3} - 3\sqrt{2} \times 3\sqrt{2}} \\ &= \frac{12+12\sqrt{6}+18}{12-18} \\ &= \frac{30+12\sqrt{6}}{-6} = -5 - 2\sqrt{6} \end{aligned}$$

Trial questions:

- Express $\frac{3\sqrt{2}-2\sqrt{3}}{3\sqrt{2}+2\sqrt{3}}$ in the form $a - b\sqrt{c}$ [Ans: $5 - 2\sqrt{6}$]
- Given that $\frac{3\sqrt{5}-2\sqrt{3}}{3\sqrt{5}+2\sqrt{3}} = p + q\sqrt{r}$. Find p, q and r [Ans: $p = \frac{19}{11}, q = \frac{-4}{11}, r = 15$]
- Rationalize the surd $\frac{1}{3\sqrt{5}-\sqrt{3}} + \frac{1}{\sqrt{5}+\sqrt{3}}$ [Ans: $\frac{1}{7}(10 + 4\sqrt{15})$]
- Simplify $\frac{\sqrt{3}-2}{2\sqrt{3}+3}$ in the form $p + q\sqrt{3}$ [Ans: $4 - \frac{7}{3}\sqrt{3}$]
- Simplify $\frac{1}{\sqrt{5}-\sqrt{3}}$ [Ans: $\frac{1}{2}(\sqrt{5} + \sqrt{3})$]
- Rationalize (i) $\frac{1}{3\sqrt{5}-\sqrt{3}} + \frac{1}{\sqrt{5}+\sqrt{3}}$ [Ans: $\frac{12\sqrt{5}-10\sqrt{3}}{21}$] (ii) $\frac{\sqrt{3}-\sqrt{2}}{\sqrt{3}+\sqrt{2}}$ [Ans: $5 - 2\sqrt{6}$]
- Simplify $\frac{1}{3-\sqrt{7}} + \frac{1}{3+\sqrt{7}}$ [Ans: 3]

8. Given that $t = \frac{1}{2}(\sqrt{5} + 1)$. Show that $t^2 = 1 + t$

INDICES:

Index is another word to mean power i.e. for $a^3 = a \times a \times a$, here a is the base and 3 is a power or an index or exponent.

Laws of indices:

1. $a^m \times a^n = a^{m+n}$ i.e. $2^3 \times 2^2 = 2^{3+2} = 2^5 = 32$

2. $a^m \div a^n = a^{m-n}$ i.e. $3^3 \div 3^2 = 3^{3-2} = 3^1 = 3$

3. $(a^m)^n = a^{mn}$ i.e. $(4^2)^3 = 4^{2 \times 3} = 4^6$

4. $a^0 = 1$ i.e. $5^0 = 1$, $\left(\frac{2}{7}\right)^0 = 1$, $1000^0 = 1$ etc

5. $a^{-n} = \frac{1}{a^n}$ i.e. $2^{-1} = \frac{1}{2^1}$, $5^{-2} = \frac{1}{5^2} = \frac{1}{25}$

6. $a^{\frac{1}{n}} = \sqrt[n]{a}$ i.e. $4^{\frac{1}{2}} = \sqrt[2]{4} = 2$

7. $a^n \times b^n = (ab)^n$ i.e. $2^2 \times 3^2 = (2 \times 3)^2 = 6^2 = 36$

8. $a^{\frac{m}{n}} = (\sqrt[n]{a})^m = \sqrt[n]{a^m}$

Examples.

1. Simplify (i) $27^{\frac{1}{3}}$ (ii) $4^{\frac{-1}{2}}$ (iii) $100^{1\frac{1}{2}}$ (iv) $(625)^{\frac{-1}{4}}$ (v) $\left(\frac{27}{1000}\right)^{\frac{-1}{3}}$

(i) $27^{\frac{1}{3}} = (3^3)^{\frac{1}{3}} = 3^{3 \times \frac{1}{3}} = 3^1 = 3$

(ii) $4^{\frac{-1}{2}} = (2^2)^{\frac{-1}{2}} = 2^{2 \times \frac{-1}{2}} = 2^{-1} = \frac{1}{2}$

(iii) $100^{1\frac{1}{2}} = 100^{\frac{3}{2}} = (10^2)^{\frac{3}{2}} = 10^{2 \times \frac{3}{2}} = 10^3 = 1000$

(iv) $(625)^{\frac{-1}{4}} = (5^4)^{\frac{-1}{4}} = 5^{4 \times \frac{-1}{4}} = 5^{-1} = \frac{1}{5}$

(v) $\left(\frac{27}{1000}\right)^{\frac{-1}{3}} = \frac{(27)^{\frac{-1}{3}}}{(1000)^{\frac{-1}{3}}} = \frac{(3^3)^{\frac{-1}{3}}}{(10^3)^{\frac{-1}{3}}} = \frac{3^{3 \times \frac{-1}{3}}}{10^{3 \times \frac{-1}{3}}} = \frac{3^{-1}}{10^{-1}} = 3^{-1} \div 10^{-1}$

$$= \frac{1}{3} \div \frac{1}{10} = \frac{1}{3} \times \frac{10}{1} = \frac{10}{3}$$

2. Simplify

$$(i) \frac{27^{\frac{1}{2}} \times 243^{\frac{1}{2}}}{243^{\frac{4}{5}}}$$

$$\frac{27^{\frac{1}{2}} \times 243^{\frac{1}{2}}}{243^{\frac{4}{5}}} = \frac{(3^3)^{\frac{1}{2}} \times (3^5)^{\frac{1}{2}}}{(3^5)^{\frac{4}{5}}} = \frac{3^{\frac{3}{2}} \times 3^{\frac{5}{2}}}{3^4} = \frac{3^{\frac{3+5}{2}}}{3^4} = \frac{3^4}{3^4} = 1$$

$$(ii) \frac{a^{\frac{1}{n}} \div a^{-n}}{a^{\left(\frac{n+1}{n}\right)}}$$

$$\frac{a^{\frac{1}{n}} \div a^{-n}}{a^{\left(\frac{n+1}{n}\right)}} = \frac{a^{\frac{1}{n}} \div \frac{1}{a^n}}{a^{\left(\frac{n+1}{n}\right)}} = \frac{a^{\frac{1}{n}} \times a^n}{a^{\left(\frac{n+1}{n}\right)}} = \frac{a^{\frac{1}{n}+n}}{a^{\left(\frac{n+1}{n}\right)}} = a^{\left(\frac{n^2+1}{n}\right) - \left(\frac{n+1}{n}\right)} = a^{\left(\frac{n^2-n}{n}\right)} = a^{n-1}$$

$$(iii) \frac{3(2^{n+1}) - 4(2^{n-1})}{2^{n+1} - 2^n}$$

$$\frac{3(2^{n+1}) - 4(2^{n-1})}{2^{n+1} - 2^n} = \frac{3(2^n \times 2) - 4(2^n \times 2^{-1})}{(2^n \times 2) - 2^n} = \frac{6(2^n) - 4\left(\frac{2^n}{2}\right)}{2^n(2-1)} = \frac{6(2^n) - 2(2^n)}{2^n} = \frac{2^n(6-2)}{2^n} = 4$$

Equations involving indices:

Solve the following equations;

1. $3^x = 81$

Solution

$$3^x = 3^4$$

$$\therefore x = 4$$

2. $27^x = \frac{1}{9}$

Solution

$$(3^3)^x = \frac{1}{3^2}$$

$$3^{3x} = 3^{-2}$$

$$3x = -2$$

$$\therefore x = \frac{-2}{3}$$

3. $4^x = 0.5$

Solution

$$4^x = \frac{1}{2}$$

$$(2^2)^x = 2^{-1}$$

$$2^{2x} = 2^{-1}$$

$$\therefore 2x = -1, x = \frac{-1}{2}$$

3. $2^{2x+3} + 1 = 9(2^x)$

solution

$$2^{2x} \times 2^3 + 1 = 9(2^x)$$

$$8(2^{2x}) - 9(2^x) + 1 = 0$$

$$8(2^x)^2 - 9(2^x) + 1 = 0 \text{ since } 2^{2x} = 2^x \times 2^x = (2^x)^2$$

Let $2^x = y$, then;

$$8y^2 - 9y + 1 = 0$$

$$8y^2 - 8y - y + 1 = 0$$

$$(8y - 1)(y - 1) = 0, \text{ either } 8y - 1 = 0 \Rightarrow y = \frac{1}{8} \text{ or } y - 1 = 0 \Rightarrow y = 1$$

$$\text{When } y = \frac{1}{8}, 2^x = \frac{1}{8} \Rightarrow 2^x = \frac{1}{2^3} \Rightarrow 2^x = 2^{-3}, x = -3$$

$$\text{When } y = 1, 2^x = 1 \leftrightarrow 2^x = 2^0, x = 0$$

$$\therefore x = 0 \text{ or } x = -3$$

$$4. 3(3^{2x}) + 26(3^x) - 9 = 0$$

Solution

$$3(3^x)^2 + 26(3^x) - 9 = 0$$

$$\text{Let } y = 3^x, \text{ then } 3y^2 + 26y - 9 = 0$$

$$3y^2 - y + 27y - 9 = 0$$

$$y(3y - 1) + 9(3y - 1) = 0$$

$$(3y - 1)(y + 9) = 0$$

$$\text{Either } 3y - 1 = 0, y = \frac{1}{3} \quad \text{or } y + 9 = 0, y = -9$$

$$\text{Either } 3^x = \frac{1}{3}, 3^x = 3^{-1} \quad \therefore x = -1$$

$$\text{Or } 3^x = -9 \text{ and value of } x \text{ does not exist}$$

$$6. 2^{2x+2} + 15(2^x) = 8$$

Solution

$$2^{2x} \times 2^1 + 15(2^x) - 8 = 0$$

$$2(2^x)^2 + 15(2^x) - 8 = 0$$

$$\text{Let } 2^x = y, \text{ then } 2y^2 + 15y - 8 = 8$$

$$2y^2 - y + 16y - 8 = 0$$

$$y(2y - 1) + 8(2y - 1) = 0$$

$$(2y - 1)(y + 8) = 0$$

$$\text{Either } 2y - 1 = 0 \text{ or } y + 8 = 0 \Rightarrow y = \frac{1}{2} \text{ or } y = -8$$

$$\text{Either } 2^x = \frac{1}{2} = 2^{-1} \Rightarrow x = -1 \text{ or}$$

$$2^x = -8 \text{ and value of } x \text{ does not exist}$$

$$\therefore x = -1$$

Trial questions:

1. Simplify

$$(i) \frac{\frac{1}{86} \times \frac{1}{43}}{\frac{1}{326} \times \frac{1}{1612}} \quad [\text{Ans: } 1]$$

$$(ii) \frac{x^{-\frac{2}{3}} \times x^{\frac{1}{4}}}{x^{\frac{1}{6}}} \quad \left[\text{Ans: } x^{-\frac{7}{12}} \right] \quad (iv) y^{\frac{3}{2}} = 64 \quad [\text{Ans: } 16]$$

$$(iii) \frac{x^{2n+1} \times x^{\frac{1}{2}}}{\sqrt{x^{3n}}} \quad \left[\text{Ans: } x^{\left(\frac{n+3}{2}\right)} \right] \quad (v) \left(\frac{27}{8}\right)^{-\frac{2}{3}} \quad [\text{Ans: } \frac{2}{3}]$$

$$(vi) \frac{\frac{1}{92} \times \frac{1}{273}}{\frac{1}{643} \times \frac{1}{162}} \quad \left[\text{Ans: } \frac{9}{16} \right] \quad (vii) \frac{32^{\frac{3}{4}} \times 16^0 \times 8^{\frac{5}{4}}}{128^{\frac{2}{3}}} \quad [\text{Ans: } \frac{1}{8}]$$

2. Solve the following equations

- (i) $9^x = \frac{1}{729}$ [Ans: $x = -3$] (ii) $8^x = 0.25$ [Ans: $x = \frac{-2}{3}$]
 (iii) $32^x = 0.25$ [Ans: $x = \frac{-2}{5}$]
 (iv) $2^{2x} - 5(2^x) + 4 = 0$ [Ans: $x = 2$ or 0]
 (v) $2^{2x+2} + 8 = 33(2^x)$ [Ans: $x = -2$ or 3]
 (vi) $3^{2x} - 12(3^x) + 27 = 0$ [Ans: $x = 2$ or 1]
 (vi) $x^4 - 4x^2 + 3 = 0$ [Ans: $x = \pm 1$ or $\pm \sqrt{3}$, hint Let $y = x^2$]
 (vii) $\left(\frac{1}{4}\right)^x \times 2^{x+1} = \frac{1}{8}$ [Ans: $x = 4$]
 (viii) $3(4^x) - 8(2^x) + 4 = 0$ [Ans: $x = 1$ or -0.585]

LOGARITHMS:

Logarithm is another word to mean index or power i.e. if $y = a^x$, then we define x as logarithm of y to base a ($\log_a y$)

if $y = a^x$, then $x = \log_a y$

Operating rules for logarithms.

- $\log_a b + \log_a c = \log_a bc$ ie $\log_2 3 + \log_2 5 = \log_2 3 \times 5 = \log_2 15$
- $\log_a b - \log_a c = \log_a \left(\frac{b}{c}\right)$ ie $\log_3 6 - \log_3 8 = \log_3 \left(\frac{6}{8}\right) = \log_3 2$
- $\log_a b^n = n \log_a b$ ie $\log_3 7^2 = 2 \log_3 7$
- $\log_a b = \frac{\log_c b}{\log_c a}$ i.e. $\log_2 3 = \frac{\log_4 3}{\log_4 2}$, $\log_2 3 = \frac{\log_{10} 3}{\log_{10} 2}$. This is known as the change of base rule.
- $\log_a b = \frac{1}{\log_b a}$
- $\log_a 1 = 0$ since $a^0 = 1$
- $\log_a a = 1$ since $a^1 = a$

Examples

1. Express the following statements in logarithm notation

- (i) $16 = 2^4$ (ii) $27 = 3^3$

Solution:

- (i) Introducing \log_2 on both sides (ii) Introducing \log_3 on both sides
 $\log_2 2^4 = \log_2 16$ $\log_3 27 = \log_3 3^3$
 $\log_2 16 = \log_2 2^4$ $\log_3 27 = 3$
 $\log_2 16 = 4$

2. Express the following in index notation

(i) $\log_2 32 = 5$ (ii) $7 = \log_2 128$

Solution:

(i) $2^5 = 32$ (ii) $2^7 = 128$

3. Simplify $\log_4 9 + \log_4 21 - \log_4 7$

Solution

$$\begin{aligned}\log_4 9 + \log_4 21 - \log_4 7 &= \log_4(9 \times 21) - \log_4 7 \\ &= \log_4\left(\frac{9 \times 21}{7}\right) = \log_4 27 = \log_4 3^3 = 3 \log_4 3\end{aligned}$$

4. If $\log_7 2 = 0.356$ and $\log_7 3 = 0.566$. Find the value of $2 \log_7 \left(\frac{7}{15}\right) + \log_7 \left(\frac{25}{12}\right) - 2 \log_7 \left(\frac{7}{3}\right)$

Solution

$$\begin{aligned}&= \log_7 \left(\frac{7}{15}\right)^2 + \log_7 \left(\frac{25}{12}\right) - \log_7 \left(\frac{7}{3}\right)^2 = \log_7 \left(\frac{49}{225}\right) + \log_7 \left(\frac{25}{12}\right) - \log_7 \left(\frac{49}{9}\right) \\ &= \log_7 \left(\frac{49}{225} \times \frac{25}{12}\right) - \log_7 \left(\frac{49}{9}\right) \\ &= \log_7 \left(\frac{49}{225} \times \frac{25}{12} \div \frac{49}{9}\right) = \log_7 \left(\frac{49}{225} \times \frac{25}{12} \times \frac{9}{49}\right) \\ &= \log_7 \left(\frac{1}{12}\right) = \log_7 1 - \log_7 12 = -\log_7 12 \\ &= -\log_7(4 \times 3) = -(\log_7 4 + \log_7 3) \\ &= -(\log_7 2^2 + \log_7 3) = -(2 \log_7 2 + \log_7 3) \\ &= -(2 \times 0.356 + 0.566) \\ &= -1.278\end{aligned}$$

5. Find the value of $\log_7 12$

Solution

Let $x = \log_7 12$, then $7^x = 12$

Introducing \log_{10} on both sides gives;

$$\log_{10} 7^x = \log_{10} 12$$

$$x \log_{10} 7 = \log_{10} 12$$

$$x = \frac{\log_{10} 7}{\log_{10} 12} = \frac{1.0792}{0.8451} = 1.277$$

6. Solve for x in $\log_5(4 - x) - \log_5(x + 2) = \log_5 x$

Solution

$\log_5 \left(\frac{4-x}{x+2}\right) = \log_5 x$. Since the logarithms are to the same bases on both sides, then;

$$\frac{4-x}{x+2} = x$$

$$4 - x = x(x + 2)$$

$$4 - x = x^2 + 2x$$

$$x^2 + 3x - 4 = 0$$

$$x^2 - x + 4x - 4 = 0$$

$$x(x - 1) + 4(x - 1) = 0$$

$$(x - 1)(x + 4) = 0 \quad \therefore \text{Either } x - 1 = 0 \Rightarrow x = 1 \text{ or } x + 4 = 0 \Rightarrow x = -4$$

7. Solve the equation $(0.2)^x = (0.5)^{x+7}$

Solution

Introducing \log_{10} on both sides gives;

$$\text{Log } 0.2^x = \text{log } 0.5^{x+7}$$

$$x \log 0.2 = (x + 7) \log 0.5$$

$$\frac{x}{x + 7} = \frac{\log 0.5}{\log 0.2} = 0.4307$$

$$x = 0.4307(x + 7)$$

$$x = 0.4307x + 3.0147$$

$$0.5693x = 3.0147$$

$$\therefore x = 5.2955$$

8. If $3 + \log_{10} x = 2 \log_{10} y$. Express x in terms of y

Solution

Using $3 \log_{10} 10 + \log_{10} x = 2 \log_{10} y$ since $\log_{10} 10 = 1$

$$\log_{10} 10^3 + \log_{10} x = \log_{10} y^2$$

$$\log_{10} 1000x = \log_{10} y^2$$

Since the logarithms are to the same bases on both sides, then;

$$1000x = y^2$$

$$\therefore x = \frac{y^2}{1000} \text{ or } x = 0.001y^2$$

9. Solve $(0.1)^x = (0.2)^5$

Solution

Introducing logarithms to base 10 on both sides ;

$$\text{Log } 0.1^x = \text{log } 0.2^5$$

$$x \log 0.1 = 5 \log 0.2$$

$$x = \frac{5 \log 0.2}{\log 0.1} = \frac{5 \times -0.69897}{-1} = 3.495$$

$$\therefore x = 3.495$$

10. Solve for x in the equation ; $\log_5 x + \log_x 5 = 2.5$

Solution

$$\log_5 x + \frac{1}{\log_5 x} = 2.5 \quad (\text{Refer to Law 5.})$$

Let $\log_5 x = y$, then $y + \frac{1}{y} = 2.5$

$$y^2 + 1 = 2.5y$$

$$10y^2 + 10 = 25y \quad (\text{multiplying through by 10})$$

$$10y^2 - 25y + 10 = 0$$

$$a = 10, b = -25 \text{ and } c = 10$$

$$y = \frac{-b \pm \sqrt{b^2 - 4ac}}{2a}$$

$$= \frac{-(-25) \pm \sqrt{(-25)^2 - 4 \times 10 \times 10}}{2 \times 10} = \frac{25 \pm \sqrt{225}}{20} = \frac{25 \pm 15}{20}$$

$$\text{either } y = \frac{25+15}{20} = \frac{40}{20} = 2 \text{ or } y = \frac{25-15}{20} = \frac{10}{20} = \frac{1}{2}$$

$$\text{Either } \log_5 x = 2 \Rightarrow 5^2 = x, \therefore x = 25$$

$$\text{Or } \log_5 x = \frac{1}{2} \Rightarrow 5^{\frac{1}{2}} = x, \therefore x = \sqrt{5}$$

11. Simplify $\log_8 2$

Solution

Using the change of base rule

$$\log_a b = \frac{\log_c b}{\log_c a}$$

We can change the base 8 to a lower base i.e. 2

$$\begin{aligned} \log_8 2 &= \frac{\log_2 2}{\log_2 8} \\ &= \frac{1}{\log_2 2^3} \\ &= \frac{1}{3 \log_2 2} = \frac{1}{3} \end{aligned}$$

12. Show that $\log_8 x = \frac{2}{3} \log_4 x$. Hence without using tables or calculator evaluate $\log_8 6$ correct to 3 decimal places given that $\log_4 3 = 0.7925$

Solution

By using change of base rule and changing the base from 8 to 4;

$$\begin{aligned} \log_8 x &= \frac{\log_4 x}{\log_4 8} \\ &= \frac{\log_4 x}{\log_4(4 \times 2)} \\ &= \frac{\log_4 x}{\log_4 4 + \log_4 2} \\ &= \frac{\log_4 x}{\log_4 4 + \log_4 4^{\frac{1}{2}}} \\ &= \frac{\log_4 x}{1 + \frac{1}{2}} \\ &= \frac{\log_4 x}{\frac{3}{2}} \end{aligned}$$

$$\log_8 x = \frac{2}{3} \log_4 x$$

Hence putting $x = 6$, we have;

$$\begin{aligned} \log_8 6 &= \frac{2}{3} \log_4(3 \times 2) \\ &= \frac{2}{3} (\log_4 3 + \log_4 2) \\ &= \frac{2}{3} (0.7925 + 0.5) \\ &= \frac{2}{3} \times 1.2925 = 0.862 \quad (3 \text{ d. p}) \end{aligned}$$

Trial questions

1. Simplify $1 + \log_{10} \left(\frac{4}{x^4} \right)^{-\frac{1}{2}} - 2 \log_{10} x$ [Ans: $\log_{10} 5$]

2. Solve the simultaneous equations ;

- $\log_{10} x - \log_{10} y = \log_{10} 2.5$ and $\log_{10} x + \log_{10} y = 1$ [Ans: $x = \pm 5$ or ± 2]
3. Find $\log_{\sqrt{5}} 30$ correct to 2 decimal places [Ans: 4.23]
4. If $p = \log_7 \left(\frac{14}{15}\right)$, $q = \log_7 \left(\frac{21}{20}\right)$, $r = \log_7 \left(\frac{49}{50}\right)$, given that $\log_7 2 = 0.356$ and $\log_7 3 = 0.566$, find the values of (a) $p + q - r$ (b) $p + 3q - 2r$
[Ans: (a) 0 (b) 0.064]
5. Solve the equation $(0.2)^x = (0.5)^{x+7}$ [Ans: $x = 5.294$]
6. Solve the equation $\log_3 x - 4 \log_x 3 + 3 = 0$ [Ans: $x = \frac{1}{81}$ or 3]
7. Solve the simultaneous equations $x + y = 20$ and $\log_3 x = \log_9 y$ [Ans: (4,6)(-5,25)]
8. Solve the equation $\log_2 x - \log_x 8 = 2$ [Ans: $x = 8$ or $\frac{1}{2}$]
9. Solve for x in the equation $\log_4(6 - x) = \log_2 x$ [Ans: $x = 2$]
10. (i) If $\log_a(2 + a) = 2$, Find a [Ans: $a = 2$ or -1] (ii) $\log_a(6 - a) = 2$
[Ans: $a = 2$ or -3]
11. Evaluate $\frac{\log 81}{\log 729}$ [Ans: $\frac{2}{3}$]
12. Determine $\log 0.27$ given that $\log 3 = 0.4771$ [Ans: -0.5687]
13. Express as a single logarithm and simplify your answer $\log \sqrt{x^2 - 1} + \frac{1}{2} \log \left(\frac{x+1}{x-1}\right)$ [Ans: $\log(x+1)$]
14. Given that $\log_3 2 = 0.63$. Find the value of x in the equation $3^{2x} = 3^x + 2$ [Ans: 0.63]
15. Simplify $\log_7 98 - \log_7 30 + \log_7 15$ [Ans: 2]

CHAPTER 2: POLYNOMIALS

Polynomials are algebraic expressions that include real numbers and variables. They contain more than one term. Polynomials are the sums of monomials.

A monomial has one term for example $5y$ or $-8x^2$ or 3 are monomials.

A sum of two monomials that are not like terms for example; $-3x^2 + 2$, or $9y - 2y^2$ is a special polynomial called a binomial. Similarly, a sum of three monomials is a trinomial for example; $-3x^2 + 3x - 2$.

Degree of a polynomial

The degree of the polynomial is the highest exponent of the variable for example; $3x^2$ has a degree of 2, $2x^5$ has a degree of 5 and 2 has a degree of **zero**. When the variable does not have an exponent - always understand that there is a '1' e.g., $3x$ is the same as $3x^1$.

$x^5 + 3x^4 + 2x^3 + x^2 - 2x + 1$ is a polynomial of degree 5

$4x^3 + 2x^2 - 7$ is a polynomial of degree 3

$2x^2 - 8x + 9$ is a polynomial of degree 2 e.t.c

Note: All quadratic expressions of the form $ax^2 + bx + c$ are polynomials of degree 2

Operations on Polynomials:**Addition of Polynomials:**

Below, the steps for addition of polynomials, the first basic operation on polynomials are clearly laid out:

1. Collect Like terms at one place
2. Add the numerical coefficients of like terms
3. Write the sum in both standard and simplest form

Examples:

1. Add the following polynomials:

- (a) $2a + 3b$ and $-4b + 5a$ (b) $6x + 2y - 3z$ and $9z + 3y - 5x$

Solution:

- (a) We know what is meant by like terms. They are terms in which literal coefficients are same. So, to add like terms means to add the numerical coefficients of two or more polynomials which have same literal coefficients.

In $2a + 3b$ and $-4b + 5a$:

$2a$ and $5a$ are like terms and $3b$ and $-4b$ is another pair of like terms.

So, add them (the like terms):

$$2a + 5a = 7a$$

$$3b - 4b = -b$$

Now, $7a$ and $-b$ are unlike terms which cannot be added like like terms.

So, the two unlike terms $7a$ and $-b$ are written and the symbol '+' is written to indicate the addition operation of polynomials in the given question

So, the sum of $2a + 3b$ and $-4b + 5a$ is $7a - b$

- (b) In $6x + 2y - 3z$ and $9z + 3y - 5x$

the like terms are $6x$ and $-5x$, $2y$ and $3y$, $-3z$ and $9z$

So, the sum of like terms is

$$6x - 5x = x$$

$$2y + 3y = 5y$$

$$-3z + 9z = 6z$$

Now write these sums connected by the addition sign '+' to indicate the sum of the two polynomials in the question (i.e. the addition operation on polynomials)

$$x + 5y + 6z$$

2. Simplify $(2x + 5y) + (3x - 2y)$

Solution

$$\begin{aligned} &(2x + 5y) + (3x - 2y) \\ &= 2x + 5y + 3x - 2y \\ &= 2x + 3x + 5y - 2y \\ &= 5x + 3y \end{aligned}$$

3. Simplify $(3x^3 + 3x^2 - 4x + 5) + (x^3 - 2x^2 + x - 4)$

Solution

$$\begin{aligned} &(3x^3 + 3x^2 - 4x + 5) + (x^3 - 2x^2 + x - 4) \\ &= 3x^3 + 3x^2 - 4x + 5 + x^3 - 2x^2 + x - 4 \\ &= 3x^3 + x^3 + 3x^2 - 2x^2 - 4x + x + 5 - 4 \\ &= 4x^3 + x^2 - 3x + 1 \end{aligned}$$

4. Simplify $(7x^2 - x - 4) + (x^2 - 2x - 3) + (-2x^2 + 3x + 5)$

Solution

It's perfectly okay to have to add three or more polynomials at once. I'll just go slowly and do each step thoroughly, and it should work out right.

$$\begin{aligned} &(7x^2 - x - 4) + (x^2 - 2x - 3) + (-2x^2 + 3x + 5) \\ &= 7x^2 - x - 4 + x^2 - 2x - 3 - 2x^2 + 3x + 5 \\ &= 7x^2 + 1x^2 - 2x^2 - 1x - 2x + 3x - 4 - 3 + 5 \\ &= 8x^2 - 2x^2 - 3x + 3x - 7 + 5 \\ &= 6x^2 - 2 \end{aligned}$$

5. Simplify $(x^3 + 5x^2 - 2x) + (x^3 + 3x - 6) + (-2x^2 + x - 2)$

Solution

$$\begin{aligned} &(x^3 + 5x^2 - 2x) + (x^3 + 3x - 6) + (-2x^2 + x - 2) \\ &= x^3 + 5x^2 - 2x + x^3 + 3x - 6 - 2x^2 + x - 2 \\ &= x^3 + x^3 + 5x^2 - 2x^2 - 2x + 3x + x - 6 - 2 \\ &= 2x^3 + 3x^2 + 2x - 8 \end{aligned}$$

Subtraction of Polynomials:

The steps for subtraction of polynomials, the second basic operation on polynomials are as follows:

1. Subtract similar terms. To do this, change the algebraic sign of what is to be subtracted and add it to the other.
2. To subtract unlike terms, just write the operation sign - before what is to be subtracted

Examples

1. Simplify $(x^3 + 3x^2 + 5x - 4) - (3x^3 - 8x^2 - 5x + 6)$

Solution

$$\begin{aligned} &(x^3 + 3x^2 + 5x - 4) - (3x^3 - 8x^2 - 5x + 6) \\ &= (x^3 + 3x^2 + 5x - 4) - (3x^3 - 8x^2 - 5x + 6) \\ &= (x^3 + 3x^2 + 5x - 4) - (3x^3) - (-8x^2) - (-5x) - (6) \\ &= x^3 + 3x^2 + 5x - 4 - 3x^3 + 8x^2 + 5x - 6 \\ &= x^3 - 3x^3 + 3x^2 + 8x^2 + 5x + 5x - 4 - 6 \\ &= -2x^3 + 11x^2 + 10x - 10 \end{aligned}$$

2. Simplify $(6x^3 - 2x^2 + 8x) - (4x^3 - 11x + 10)$

Solution

$$\begin{aligned} & (6x^3 - 2x^2 + 8x) - (4x^3 - 11x + 10) \\ &= (6x^3 - 2x^2 + 8x) - 1(4x^3 - 11x + 10) \\ &= (6x^3 - 2x^2 + 8x) - 1(4x^3) - 1(-11x) - 1(10) \\ &= 6x^3 - 2x^2 + 8x - 4x^3 + 11x - 10 \\ &= 6x^3 - 4x^3 - 2x^2 + 8x + 11x - 10 \\ &= 2x^3 - 2x^2 + 19x - 10 \end{aligned}$$

Multiplication of Polynomials:

Multiplication of polynomials is the third important operation on polynomials. Here are the steps to follow when multiplying polynomials;

- First multiply numerical coefficients and literal coefficients separately. Next, multiply these two products
- To multiply two polynomials when each one has more than one term: Multiply each term of one polynomial with each term of the other polynomial and write like terms together.

Examples:

Multiply the following polynomials:

1. $5p$ and $8q$

Solution:

Product of numerical coefficients 5 and 8 is 40 and product of literal coefficients p and q is pq .

Now, write the product of these two as: $40pq$.

2. $4x^3 + 2$ and $2x^2 + 3x$

Solution:

$$4x^3 + 2 \text{ and } 2x^2 + 3x$$

Let us apply the 2nd rule

$$\begin{aligned} (4x^3 + 2)(2x^2 + 3x) &= 4x^3 \cdot (2x^2 + 3x) + 2(2x^2 + 3x) \\ &= 8x^5 + 12x^4 + 4x^2 + 6x \quad \{ \text{Apply exponents rule: } x^m \times x^n = x^{m+n} \} \end{aligned}$$

Division of Polynomials:

1. To divide a monomial by another monomial, divide the numerical coefficients and the literal coefficients separately.
2. To divide a polynomial by a monomial, divide each term in the polynomial by the monomial.

Examples:

Divide the following polynomials

1. $50p^4q^6$ by $5pq$

Solution:

Divide the numerical coefficients and write their quotient i.e., $50/5 = 10$ now divide literal coefficients and write their quotient as

$$\begin{aligned} & p^4q^6 \text{ by } pq \quad \{ \text{recall exponents rule: } \{ x^m/x^n = x^{m-n} \} \\ & \frac{p^4q^6}{pq} \\ &= p^{4-1} \cdot q^{6-1} = p^3 \cdot q^5 \end{aligned}$$

Now, write the coefficients next to each other to denote their product $50 p^3 \cdot q^5$

2. Divide $40a^5b^4 + 55a^3b^5 + 35a^3b^4 + 70ab$ by a^2b^2

Solution:

Divide each in the polynomial $40a^5b^4 + 55a^3b^5 + 35a^3b^4 + 70ab$ by a^2b^2

Let us find the quotients separately as follows:

$$(40a^5b^4)/(a^2b^2) = 40a^{5-2} \cdot b^{4-2} = 40a^3b^2$$

$$(55a^3b^5)/(a^2b^2) = 55ab^3$$

$$(35a^3b^4)/(a^2b^2) = 35ab^2$$

$$(70ab)/(a^2b^2) = 70/(ab)$$

Now write the above four quotients next to each other, separated by the + sign to indicate their addition

$$40a^3b^2 + 55ab^3 + 35ab^2 + 70/(ab)$$

Factorisation of polynomials of degree 2

The polynomials of degree 2 i.e. in the form $ax^2 + bx + c$ can be factorised in the steps in the following example.

Example: Factorise $6x^2 + 13x + 6$

Solution

1. Multiply the a term (6 in the example) by the c term (also 6 in the example).

$$6 \times 6 = 36$$

2. Find two numbers that when multiplied equal this number (36) and add up to be the b term (13).

$$4 \times 9 = 36 \text{ and } 4 + 9 = 13$$

3. Substitute the two numbers you get into this form as k and h (order doesn't matter):

$$ax^2 + kx + hx + c$$

$$6x^2 + 4x + 9x + 6$$

4. Factor the polynomial by grouping. Organize the equation so that you can take out the greatest common factor of the first two terms and the last two terms. Both factored groups should be the same. Add the GCF's together and enclose them in brackets next to the factored group.

$$6x^2 + 4x + 9x + 6$$

$$2x(3x + 2) + 3(3x + 2)$$

$$(2x + 3)(3x + 2)$$

Difference of Two Squares

If you see something of the form $a^2 - b^2$, you should remember the formula

$$(a + b)(a - b) = a^2 - b^2$$

Example: $x^2 - 4 = (x - 2)(x + 2)$

Solving simple polynomials

Example: Solve $3x^3 + 2x^2 - x = 0$

Solution

This is cubic ... but wait, you can factor out "x":

$$3x^3 + 2x^2 - x = x(3x^2 + 2x - 1) = 0$$

Now we have one root ($x=0$) and what is left is quadratic, which we can solve exactly by factorising it.

$$\text{either } x = 0 \text{ or } 3x^2 + 2x - 1 = 0$$

Now solving $3x^2 + 2x - 1 = 0$, we have;

$$3x^2 + 3x - x - 1 = 0$$

$$3x(x + 1) - (x + 1) = 0$$

$$(x + 1)(3x - 1) = 0$$

$$\text{either } x + 1 = 0 \rightarrow x = -1 \text{ or } 3x - 1 = 0 \rightarrow x = \frac{1}{3}$$

$$\text{Therefore } x = 0, x = -1 \text{ and } x = \frac{1}{3}$$

Evaluation of a polynomial

Evaluation of a polynomial is a process of substituting a given value in the polynomial i.e a polynomial can be evaluated at $x = 2$ or by obtaining $f(2)$.

Note that $f(x)$ is **not** 'f multiplied by x' **but** means the 'value of the expression' for example: $f(a)$ means 'the value of the expression when $x = a$ '.

Example 1

If $f(x) = 2x^3 - 3x^2 - 5x + 6$, find $f(1)$

Solution

$$f(1) = 2(1)^3 - 3(1)^2 - 5(1) + 6 = 2 - 3 - 5 + 6 = 0$$

Example 2

if $f(x) = x^3 - 2x^2 - 5x + 6$, find $f(-1)$ and $f(1)$

Solution

$$f(-1) = (-1)^3 - 2(-1)^2 - 5(-1) + 6 = -1 - 2 + 5 + 6 = 10$$

$$f(1) = (1)^3 - 2(1)^2 - 5(1) + 6 = 1 - 2 - 5 + 6 = 0$$

Trial questions

- Add $(2x^2 + x + 1) + (3x^2 - 5x + 2)$ [Ans : $5x^2 - 4x + 3$]
- Multiply $(3x^2 + 2x - 1)(5x - 1)$ [Ans: $15x^3 + 7x^2 - 7x + 1$]
- Multiply $(x - 3)(x^2 + 4x - 6)$ [Ans: $x^3 + x^2 - 18x + 18$]
- Factorise the following degree 2 polynomials
 - $x^2 + 5x + 6$
 - $x^2 - 5x + 6$
 - $x^2 + 4x - 21$
 - $x^2 - 9$
 - $2x^2 - 11x + 5$
 - $x^2 - 4x + 4$

[Ans: (a) $(x + 3)(x + 2)$ (b) $(x - 3)(x - 2)$ (c) $(x - 3)(x + 7)$ (d) $(x - 3)(x + 3)$
(e) $(x - 5)(2x - 1)$ (f) $(x - 2)(x - 2)$]

- Evaluate the following polynomials for the given values of x
 - $f(x) = 4x^3 + 15x^2 - 18x + 7$ when $x = -3$
 - $f(x) = 4x^3 + 15x^2 - 18x + 7$ when $x = \frac{1}{2}$
 - $f(x) = x^3 + 3x^2 - 9x - 5$ when $x = -3$
 - $f(x) = x^3 + 3x^2 - 9x - 5$ when $x = 1$

[Ans: (a) 88 (b) $\frac{9}{4}$ (c) 22 (d) -10]

CHAPTER 3: QUADRATIC EQUATIONS

Any equation of the form $ax^2 + bx + c = 0$ is called a quadratic equation and the values of x , which satisfy the equation, are called roots.

Solution of a quadratic equation that factorizes**Example**

1. Find the roots of the equation $x^2 - 5x + 6 = 0$

Solution

$$x^2 - 2x - 3x + 6 = 0$$

$$x(x - 2) - 3(x - 2) = 0$$

$$(x - 2)(x - 3) = 0 \quad \text{Either } x - 2 = 0, x = 2 \quad \text{or } x - 3 = 0, x = 3$$

Solution of a quadratic equation that does not factorize**By completing the square**

This method uses the expansion $(x + b)^2 = x^2 + 2bx + b^2$. It is important to note that the last term b^2 , is the square of half the coefficient of x , $(2b)$.

Examples

1. Find the roots of the equation $2x^2 - 5x + 1 = 0$

Solution

Dividing through by 2 gives;

$$x^2 - \frac{5}{2}x + \frac{1}{2} = 0$$

$$x^2 - \frac{5}{2}x = -\frac{1}{2}$$

Adding the square of half the coefficient of x to both sides of the equation;

$$x^2 - \frac{5}{2}x + \left(\frac{5}{4}\right)^2 = -\frac{1}{2} + \left(\frac{5}{4}\right)^2$$

$$\left(x - \frac{5}{4}\right)^2 = -\frac{1}{2} + \frac{25}{16}$$

$$\left(x - \frac{5}{4}\right)^2 = \frac{17}{16}$$

$$\sqrt{\left(x - \frac{5}{4}\right)^2} = \sqrt{\frac{17}{16}}$$

$$x - \frac{5}{4} = \frac{\sqrt{17}}{4}$$

$$x = \frac{5 \pm \sqrt{17}}{4} \quad \therefore x = 2.281 \quad \text{or } x = 0.219$$

2. Solve $2x^2 - 6x + 4 = 0$

Solution

$$2x^2 - 6x + 4 = 0$$

$$x^2 - 3x + 2 = 0$$

$$x^2 - 3x = -2$$

Adding the square of half the coefficient of x to each side of the equation

$$\begin{aligned}
 x^2 - 3x + \left(\frac{3}{2}\right)^2 &= -2 + \left(\frac{3}{2}\right)^2 \\
 \left(x - \frac{3}{2}\right)^2 &= -2 + \frac{9}{4} \\
 \left(x - \frac{3}{2}\right)^2 &= \frac{1}{4} \\
 \sqrt{\left(x - \frac{3}{2}\right)^2} &= \sqrt{\frac{1}{4}} \\
 x - \frac{3}{2} &= \pm \frac{1}{2} \\
 x &= \frac{3 \pm 1}{2} && x = 2 \text{ or } x = 1
 \end{aligned}$$

3. Solve $x^2 + 3x - 1 = 0$

Solution

$$x^2 + 3x = 1$$

Adding the square of half the coefficient of x to each side of the equation gives;

$$\begin{aligned}
 x^2 + 3x + \left(\frac{3}{2}\right)^2 &= 1 + \left(\frac{3}{2}\right)^2 \\
 (x + 3)^2 &= \frac{13}{4} \\
 x + \frac{3}{2} &= \pm \frac{\sqrt{13}}{2} \text{ giving } x = \frac{\sqrt{13}-3}{2} \text{ or } x = \frac{-\sqrt{13}-3}{2} \\
 x &= 0.30 \text{ or } -3.30
 \end{aligned}$$

Note: The method of completing the square, used to solve $ax^2 + bx + c = 0$ can also be used to find the maximum or minimum value of the expression $ax^2 + bx + c$.

For example, consider the expression $x^2 + 3x + 4$

$$\begin{aligned}
 x^2 + 3x + 4 &= x^2 + 3x + \left(\frac{3}{2}\right)^2 - \left(\frac{3}{2}\right)^2 + 4 \\
 &= \left(x + \frac{3}{2}\right)^2 + \frac{7}{4}
 \end{aligned}$$

Now $\left(x + \frac{3}{2}\right)^2$ cannot be negative for any value of x , i.e. $\left(x + \frac{3}{2}\right)^2 \geq 0$

Thus $x^2 + 3x + 4$ is always positive and will have a minimum value of $\frac{7}{4}$ when $x + \frac{3}{2} = 0$, i.e. when

$$x = -\frac{3}{2}$$

Example

Find the maximum value of $5 - 2x - 4x^2$

Solution

$$\begin{aligned}
 \text{Let's first rewrite } 5 - 2x - 4x^2 &= -4x^2 - 2x + 5 \\
 &= -4\left(x^2 + \frac{1}{2}x\right) + 5 \\
 &= -4\left(x^2 + \frac{1}{2}x + \frac{1}{16}\right) + \frac{4}{16} + 5 \\
 &= -4\left(x + \frac{1}{4}\right)^2 + \frac{21}{4} \\
 &= \frac{21}{4} - 4\left(x + \frac{1}{4}\right)^2
 \end{aligned}$$

$$\text{Now } \left(x + \frac{1}{4}\right)^2 \geq 0$$

Thus $5 - 2x - 4x^2$ has a maximum value of $\frac{21}{4}$ when $x = -\frac{1}{4}$

IN GENERAL

For a quadratic equation $ax^2 + bx + c = 0$, the roots can be obtained from the formula;

$$x = \frac{-b \pm \sqrt{b^2 - 4ac}}{2a}$$

Example

Solve $x^2 + 3x - 1 = 0$

Solution

Comparing with the general equation $ax^2 + bx + c = 0$ $a = 1, b = 3, c = -1$

Substituting in the formula

$$x = \frac{-b \pm \sqrt{b^2 - 4ac}}{2a}$$

$$x = \frac{-3 \pm \sqrt{3^2 - 4 \times 1 \times -1}}{2 \times 1}$$

$$x = \frac{-3 \pm \sqrt{9+4}}{2}$$

$$x = \frac{-3 + \sqrt{13}}{2} \quad \text{Or } x = \frac{-3 - \sqrt{13}}{2} \quad \therefore x = 0.30, x = -3.30$$

ROOTS OF QUADRATIC EQUATIONS

If the equation $ax^2 + bx + c = 0$ has roots α and β , then its equivalent equation will be;

$$(x - \alpha)(x - \beta) = 0, \text{ as it gives } x = \alpha \text{ or } x = \beta$$

$$x^2 - \beta x - \alpha x + \alpha\beta = x^2 + \frac{b}{a}x + \frac{c}{a}$$

$$x^2 - (\alpha + \beta)x + \alpha\beta = x^2 + \frac{b}{a}x + \frac{c}{a}$$

By comparing the coefficients on both sides, we obtain

$$\alpha + \beta = -\frac{b}{a} \quad \text{and} \quad \alpha\beta = \frac{c}{a}$$

Hence the equation $ax^2 + bx + c = 0$ can be written in the form;

$$x^2 - (\text{Sum of roots})x + (\text{product of roots}) = 0$$

Example

1. Write down the sum and product of the roots of the following equations;

(i) $3x^2 - 2x - 7 = 0$ (ii) $5x^2 + 11x + 3 = 0$ (iii) $2x^2 + x - 7 = 0$

Solution

(i) $x^2 - \frac{2}{3}x - \frac{7}{3} = 0$; sum of roots $= -\left(-\frac{2}{3}\right) = \frac{2}{3}$ and product of roots $= -\frac{7}{3}$

(ii) $x^2 + \frac{11}{5}x + \frac{3}{5} = 0$; sum of roots $= -\frac{11}{5}$ and product of roots $= \frac{3}{5}$

(iii) $x^2 + \frac{1}{2}x - \frac{7}{2} = 0$; sum of roots $= \frac{1}{2}$ and product of roots $= -\frac{7}{2}$

2. Find the equation whose roots are $\frac{3}{4}$ and $-\frac{1}{2}$

Solution

Sum of roots $= \frac{3}{4} + \left(-\frac{1}{2}\right) = \frac{1}{4}$ and product of roots $= \frac{3}{4} \times \left(-\frac{1}{2}\right) = -\frac{3}{8}$

The equation is in the form $x^2 - (\text{Sum of roots})x + (\text{product of roots}) = 0$

$$x^2 - \left(\frac{1}{4}\right)x + \left(\frac{-3}{8}\right) = 0$$

$$8x^2 - 2x - 3 = 0$$

3. Find the equations whose roots are $\frac{1}{3}$ and $-\frac{1}{4}$

Solution

$$\text{Sum of roots} = \frac{1}{3} + -\frac{1}{4} = \frac{1}{3} - \frac{1}{4} = \frac{4-3}{12} = \frac{1}{12}$$

$$\text{Product of roots} = \frac{1}{3} \times -\frac{1}{4} = -\frac{1}{12}$$

The equation is in the form $x^2 - (\text{Sum of roots})x + (\text{product of roots}) = 0$

$$x^2 - \left(\frac{1}{12}\right)x + \left(\frac{-1}{12}\right) = 0$$

$$12x^2 - x - 1 = 0$$

4. The roots of the equation $3x^2 + 4x - 5 = 0$ are α and β , find the values of;

(i) $\frac{1}{\alpha} + \frac{1}{\beta}$ (ii) $\alpha^2 + \beta^2$

Solution

$$\alpha + \beta = -\frac{4}{3} \qquad \alpha\beta = -\frac{5}{3}$$

(i) $\frac{1}{\alpha} + \frac{1}{\beta} = \frac{\alpha + \beta}{\alpha\beta} = \frac{-\frac{4}{3}}{-\frac{5}{3}} = -\frac{4}{3} \times -\frac{3}{5} = \frac{4}{5}$

(ii) From $(\alpha + \beta)^2 = (\alpha + \beta)(\alpha + \beta) = \alpha^2 + 2\alpha\beta + \beta^2$

$$\alpha^2 + \beta^2 = (\alpha + \beta)^2 - 2\alpha\beta$$

$$\begin{aligned} &= \left(\frac{-4}{3}\right)^2 - 2\left(\frac{-5}{3}\right) \\ &= \frac{16}{9} + \frac{10}{3} = \frac{16+30}{9} = 5\frac{1}{9} \end{aligned}$$

5. The roots of the equation $2x^2 - 7x + 4 = 0$ are α and β . Find the equation whose roots are $\frac{\alpha}{\beta}$ and $\frac{\beta}{\alpha}$.

Solution

From the given equation, sum of roots, $\alpha + \beta = \frac{7}{2}$ and product of roots $\alpha\beta = 2$

For the new roots, $\text{sum } \frac{\alpha}{\beta} + \frac{\beta}{\alpha} = \frac{\alpha^2 + \beta^2}{\alpha\beta} = \frac{(\alpha + \beta)^2 - 2\alpha\beta}{\alpha\beta} = \frac{\left(\frac{7}{2}\right)^2 - 4}{2} = \frac{\left(\frac{49}{4}\right) - 4}{2} = \frac{33}{8}$

Product of new roots, $\frac{\alpha}{\beta} \times \frac{\beta}{\alpha} = 1$

The equation is given by $x^2 - (\text{Sum of roots})x + (\text{product of roots}) = 0$

$$x^2 - \frac{33}{8}x + 1 = 0$$

$$8x^2 - 33x + 8 = 0$$

6. Find the values of k if the roots of the equation $3x^2 + 5x - k = 0$ differ by 2

Solution

Let one root be α , then the other will be $\alpha + 2$

Sum of roots $\alpha + \alpha + 2 = -\frac{5}{3}$, $2\alpha = -\frac{5}{3} - 2 \Rightarrow \alpha = -\frac{11}{6}$

Product of roots $\alpha(\alpha + 2) = -\frac{k}{3}$, $\alpha^2 + 2\alpha = -\frac{k}{3}$ ***

Substituting for α in equation *** gives;

$$\left(-\frac{11}{6}\right)^2 + 2\left(-\frac{11}{6}\right) = -\frac{k}{3}$$

$$\frac{121}{36} - \frac{22}{6} = -\frac{k}{3}$$

$$\frac{121-132}{36} = -\frac{k}{3}, \quad -\frac{11}{36} = -\frac{k}{3} \quad \therefore k = \frac{11}{12}$$

7. If one of the roots of the equation $27x^2 + bx + 8 = 0$ is the square of the other, find b.

Solution

Let one root be α , then the other will be α^2 , then;

Sum of roots $\alpha + \alpha^2 = -\frac{b}{27} \dots \dots (i)$ and product of roots $\alpha \times \alpha^2 = \frac{8}{27} \dots \dots (ii)$

$\alpha^3 = \left(\frac{2}{3}\right)^3$ hence $\alpha = \frac{2}{3}$ Which we substitute in equation (i) to find b;

$$\frac{2}{3} + \left(\frac{2}{3}\right)^2 = -\frac{b}{27}$$

$$\frac{2}{3} + \frac{4}{9} = -\frac{b}{27}$$

$$\frac{10}{9} = -\frac{b}{27} \quad \therefore b = -30$$

The discriminant

The value of the expression $(b^2 - 4ac)$ will determine the nature of the roots of the quadratic equation $ax^2 + bx + c = 0$ and it is called discriminant i.e. it discriminates between the roots of the equation.

For;

(i) Two real roots, $b^2 - 4ac > 0$

(ii) Repeated or equal roots $b^2 - 4ac = 0$

(iii) No real roots, $b^2 - 4ac < 0$

Example

Given that the equation

$(5a + 1)x^2 - 8ax + 3a = 0$ has equal roots, find the possible values of a

Solution

We identify a, b and c from the above equation and then apply the condition for equal roots

$a = (5a + 1)$, $b = -8a$ and $c = 3a$

For equal roots, $b^2 - 4ac = 0$

$$(-8a)^2 - 4(5a + 1)(3a) = 0$$

$$64a^2 - 12a(5a + 1) = 0$$

$$64a^2 - 60a^2 - 12a = 0$$

$$4a^2 - 12a = 0$$

$$4a(a - 3) = 0$$

$$\text{Either } 4a = 0 \quad \text{or } a - 3 = 0 \quad \therefore a = 0 \text{ or } a = 3$$

Trial questions

1. State (i) the sum (ii) the product of the roots of each of the following equations

(a) $x^2 + 9x + 4 = 0$ (b) $x^2 - 7x + 2 = 0$ (c) $2x^2 - 7x + 1 = 0$ (d) $3x^2 + 10x - 2 = 0$

[Ans: a) -9, 4 (b) 2, -5 (c) 7/2, 1/2 (d) -10/3, -2/3]

2. In each part of this question, you are given the sum and product of the roots of a quadratic.

Find the quadratic equation in the form $ax^2 + bx + c = 0$

	a	b	c	D	e	f	g
sum	-3	6	7	-2/3	-5/2	-3/4	-1/4
Product	-1	-4	-5	-7/3	-2	-5	-1/3

[Ans: (a) $x^2 + 3x - 1 = 0$ (b) $x^2 - 6x - 4 = 0$ (c) $x^2 - 7x - 5 = 0$ (d) $3x^2 + 2x - 7 = 0$
(e) $x^2 + 5x - 4 = 0$ (f) $2x^2 + 3x - 10 = 0$ (g) $12x^2 + 3x - 4 = 0$]

3. If α, β are the roots of the equation $3x^2 - x - 1 = 0$, form the equations whose roots are;

(i) $2\alpha, 2\beta$ (ii) α^2, β^2 (iii) $\frac{1}{\alpha}, \frac{1}{\beta}$ (iv) $\alpha + 1, \beta + 1$

[Ans: (i) $3x^2 - 2x - 4 = 0$ (ii) $9x^2 - 7x + 1 = 0$ (iii) $x^2 + x - 3 = 0$ (iv) $3x^2 - 7x + 3 = 0$]

4. One of the roots of the equation $ax^2 + bx + c = 0$ is three times the other. Show that

$$3b^2 - 16ac = 0$$

5. If the roots of the equation $2x^2 - 7x + 1 = 0$ are α and β . find the quadratic equation whose roots are $\frac{1}{\alpha^2}$ and $\frac{1}{\beta^2}$ [Ans: $x^2 + 45x + 4 = 0$]

6. Given that α and β are the roots of the quadratic equation $3x^2 - x - 5 = 0$. Form the equation whose roots are $2\alpha - \frac{1}{\beta}$ and $2\beta - \frac{1}{\alpha}$ [Ans: $15x^2 - 13x - 169 = 0$]

7. One root of the equation $2x^2 - x + c = 0$ is twice the other. Find the value of c [Ans: $c = \frac{1}{9}$]

8. Find the value of k for which the equation $4(x - 1)(x - 2) = k$ has roots which differ by 2 [Ans: $k = 3$]

9. If the roots of the equation $x^2 + px + 7 = 0$ are α and β . Find the possible values of p [Ans: $p = \pm 6$]

10. Find the quadratic equation, which has the difference of its roots equal to 2 and the difference of the squares of its roots equal to 5. [Ans: $16x^2 - 40x + 9 = 0$]

11. Each of the following expressions has a maximum or minimum value for all real values

Find (i) which it is, maximum or minimum, (ii) its value, (iii) the value of x

(a) $x^2 + 4x - 3$ [Ans: (i) min (ii) -7 (iii) -2]

(b) $2x^2 + 3x + 1$ [Ans: (i) min (ii) $-\frac{1}{8}$ (iii) $-\frac{3}{4}$]

(c) $x^2 - 6x + 1$ [Ans: (i) min (ii) -8 (iii) 3]

(d) $3 - 2x - x^2$ [Ans: (i) max (ii) 4 (iii) -1]

(e) $5 + 2x - x^2$ [Ans: (i) max (ii) 6 (iii) 1]

CHAPTER 4: SERIES

Sequences

Consider the following sets of numbers

2, 4, 6, 8, 10,

1, 2, 4, 8, 16,

4, 9, 16, 25, 36,.....

Each set of numbers in the order given has a pattern and there is an obvious rule for obtaining the next number and as many subsequent numbers we wish to find. Such sets are called sequences and each number in the set is a term of the sequence.

Series

When the terms of a sequence are added, a series is formed i.e.

1 + 2 + 4 + 8 + 16 + is a series

As each term is a power of 2, we can write this series in the form;

$$2^0 + 2^1 + 2^2 + 2^3 + 2^4 + \dots$$

All the terms of this series are of the form 2^r , so 2^r is the general term

We can then define the series as the sum of terms of the form 2^r where r takes on values from 0 to 4 if we decide to take the first five terms.

Using Σ as a symbol for “the sum of terms such as”, we can redefine our series concisely as;

$$\sum_{r=0}^4 2^r$$

$\sum_{r=2}^{10} r^3$ means "the sum of all terms of the form r^3 where r takes all values from 2 to 10 inclusive i. e.

$$\sum_{r=2}^{10} r^3 = 2^3 + 3^3 + 4^3 + 5^3 + 6^3 + 7^3 + 8^3 + 9^3 + 10^3$$

We shall consider two important series or progressions i.e. arithmetic and geometrical progressions.

ARITHMETIC PROGRESSIONS (A.P)

The difference between any term (except the first) and its predecessor (the term immediately in front) is constant in this series. This is called the common difference, **d**, of the A.P

Consider

(a) 5, 8, 11, 14 d=3 (c) -5, -1, 3, 7, d=4

(b) 1+3+5+7+.....+99 d=2

In general, if we denote the first by a, then;

No. of term	1	2	3	4	n
Denoted by	T_1	T_2	T_3	T_4	T_n
Term	a	a+d	a+d+d a+2d	a+2d+d a+3d	a+(n-1)d

\therefore For any A.P, $T_n = a + (n - 1)d$ whe T_n is the nth term

Examples

1. Find the 35th term of 5, 9, 13

Solution

$$a=5, \quad d=9 - 5 = 4 \quad \text{and } n = 35$$

$$T_{35} = 5 + (34)(4)$$

$$=141$$

2. How many terms are in the A.P $2 + 4 + 6 + \dots + 46$?

Solution

$$a = 2 \quad d = 2 \quad \text{nth term} = 46$$

$$T_n = a + (n - 1)d$$

$$46 = 2 + (n - 1)2$$

$$2n = 46 \quad \therefore n = 23 \text{ terms}$$

3. The 7th term of an A.P is 27 and the 12th term is 47. Find the first term and common difference of the progression.

Solution

$$T_7 = a + 6d = 27 \dots\dots\dots (i)$$

$$T_{12} = a + 11d = 47 \dots\dots\dots (ii)$$

equation (ii) - (i) gives

$$5d = 20, \quad d = 4$$

Using (i) $a + 6 \times 4 = 27$

$$a + 24 = 27$$

Sum of an arithmetic progression

If S_n is the sum of the first n terms of an A.P with the last term l

then	$S_n =$	a	$+$	$(a + d)$	$+$	$(a + 2d)$	$+$	\dots	$+$	$(l - d)$	$+$	l
reversing	$S_n =$	l	$+$	$(l - d)$	$+$	$(l - 2d)$	$+$	\dots	$+$	$(a + d)$	$+$	a
adding	$2S_n =$	$(a + l)$	$+$	$(a + l)$	$+$	$(a + l)$	$+$	\dots	$+$	$(a + l)$	$+$	$(a + l)$

As there are n terms, we have $2S_n = n(a + l)$

$$\Rightarrow S_n = \frac{n}{2}(a + l)$$

Also because the nth term, l , is equal to $a + (n - 1)d$

$$S_n = \frac{n}{2}(a + a + (n - 1)d)$$

$$S_n = \frac{n}{2}[2a + (n - 1)d]$$

Either of these formulae can be used to find the sum of the first n terms of an A.P

Examples

1. Find the sum of the first 12 terms of the AP 3, 7, 11 ...

Solution

$$a = 3, \quad d = 4 \quad n = 12$$

$$S_{12} = \frac{12}{2}(2(3) + (12 - 1)4) = 6(6 + 44) = 6(50) = 300$$

2. Find the sum of the series $11 + 13 + 15 + \dots + 89$

Solution

$$a = 11, d = 2 \quad nth \text{ term} = 89$$

$$89 = 11 + (n - 1) \times 2$$

$$78 = 2(n - 1)$$

$$39 = n - 1 \quad \therefore n = 40$$

$$S_n = \frac{n}{2}(2a + (n - 1)d)$$

$$S_{40} = \frac{40}{2}(2 \times 11 + (40 - 1)2) = 2000$$

3. Find the sum of the first 20 terms of an A.P $1 + 3 + 5 + 7 + 9 + \dots$

Solution

$$n = 20$$

$$a = 1$$

$$d = 3 - 1 = 2$$

$$S_n = \frac{n}{2}(2a + (n - 1)d)$$

$$S_{20} = \frac{20}{2}(2(1) + (20 - 1) \times 2)$$

$$= 10(2 + 19 \times 2)$$

$$= 10(2 + 38) = 10 \times 40 = 400$$

4. The last term of an A.P is 84 and that there are 40 terms altogether. If the sum of the terms is 4200. Find the first term and common difference.

Solution

$$l = 84, n = 40$$

$$S_{40} = 4200$$

$$S_n = \frac{n}{2}(a + l)$$

$$4200 = \frac{40}{2}(a + 84)$$

$$210 = a + 84$$

$$a = 210 - 84 = 126$$

$$\text{From } T_n = a + (n - 1)d$$

$$84 = 126 + (40 - 1)d$$

$$84 = 126 + 39d$$

$$-42 = 39d$$

$$d = -\frac{42}{39} = -\frac{14}{13}$$

Therefore the first term is 126 and the common difference is $-\frac{14}{13}$

5. The fourth term of an AP is 13 and the tenth term is 31. Find the sum of the first ten terms of the AP

Solution

$$T_4 = a + 3d = 13 \dots \dots \dots (i)$$

$$T_{10} = a + 9d = 31 \dots \dots \dots (ii)$$

Solving (i) and (ii) simultaneously ie (ii) - (i)

$$6d = 18 \quad \therefore d = 3$$

$$a + 3 \times 3 = 13$$

$$a = 4$$

$$\text{For } n = 10, S_{10} = \frac{10}{2}(2 \times 4 + (10 - 1)3) = 5(35) = 175$$

\therefore The sum of the ten terms of the AP is 175

6. Find the fifteenth term and the sum of the first eight terms of

(a) The A.P $2 + 5 + 8 + 11 + \dots$

(b) The A.P in which the first term is 37 and the common difference is -4

Solution

(a) $a = 2, d = 5 - 2 = 3$

$$T_n = a + (n - 1)d$$

$$T_{15} = 2 + (15 - 1) \times 3$$

$$= 2 + 14 \times 3 = 44$$

$$S_n = \frac{n}{2}[2a + (n - 1)d]$$

$$S_8 = \frac{8}{2}[2(2) + (8 - 1) \times 3]$$

$$= 4(4 + 21)$$

$$= 100$$

(b) $a = 37, d = -4$

$$\text{Using } T_n = a + (n - 1)d$$

$$T_{15} = 37 + (15 - 1)(-4)$$

$$= 37 - 66$$

$$= -19$$

$$S_n = \frac{n}{2}[2a + (n - 1)d]$$

$$S_8 = \frac{8}{2}[2(37) + (8 - 1)(-4)]$$

$$= 4[74 - 28]$$

$$= 184$$

7. Find the sum of the arithmetic progression $8.5 + 12 + 15.5 + 19 + \dots + 103$

Solution

The n th term is 103

$$\Rightarrow a + (n - 1)d = 103$$

but $a = 8.5$ and $d = 12 - 8.5 = 3.5$

$$8.5 + (n - 1) \times 3.5 = 103$$

$$8.5 + 3.5n - 3.5 = 103$$

$$3.5n = 98$$

$$n = 98$$

$$\text{Using } S_n = \frac{n}{2}(a + l)$$

$$S_{98} = \frac{98}{2}(8.5 + 103)$$

$$= 49(111.5) = 5464.5$$

Alternatively;

$$\text{Using } S_n = \frac{n}{2} [2a + (n-1)d]$$

$$S_{28} = \frac{28}{2} [2(8.5) + (28-1)(3.5)]$$

$$= 1561$$

GEOMETRIC PROGRESSION S (G.Ps)

The ratio of each term (except the first) to its predecessor is a constant in this series. It is called the common ratio denoted by r i.e.

- (a) 2,4,8,16..... $r=2$ (c) 144, 72,36,18,..... $r=\frac{1}{2}$
 (b) -3, 6,-12, 24... $r=-2$

In general, if we denote the first term by a

T_1	T_2	T_3	T_4	T_5
a	$a \times r$ ar	$a \times r \times r$ ar^2	$ar^2 \times r$ ar^3	$ar^3 \times r$ ar^4

We can deduce that $T_n = ar^{n-1}$ where T_n is the n th term

Examples

1. Find the 20th term of the GP 2, 6, 18...

Solution

Here $r = \frac{6}{2} = 3$ and $a=2$

$$T_n = ar^{n-1}$$

$$T_{20} = 2 \times 3^{20-1} = 2 \times 3^{19} = 2324522934$$

2. Find the third and tenth term of the GP 3+6+.....+10

Solution

$$a = 3, \text{ common ratio}(r) = \frac{6}{3} = 2$$

$$3^{\text{rd}} \text{ term} = ar^2 = 3 \times 2^2 = 12$$

$$10^{\text{th}} \text{ term} = ar^9 = 3 \times 2^9 = 1536$$

3. The second term of a GP is $\frac{8}{9}$ and the sixth term is $4\frac{1}{2}$. Find the first term and the first term and common ratio

Solution

$$T_2 = ar = \frac{8}{9} \dots \dots (i)$$

$$T_6 = ar^5 = \frac{9}{2} \dots \dots \dots (ii)$$

equation (ii) \div (i) gives;

$$\frac{ar^5}{ar} = \frac{\frac{9}{2}}{\frac{8}{9}} = \frac{81}{16}$$

$$r^4 = \frac{81}{16} = \frac{3^4}{2^4} = \left(\frac{3}{2}\right)^4$$

$$\therefore r = \frac{3}{2}$$

$$\text{From (i) } ar = \frac{8}{9}, a \left(\frac{3}{2}\right) = \frac{8}{9}$$

$$\therefore a = \frac{16}{27}$$

The sum of a GP

The sum of n terms of a GP is given by the formula;

$$s_n = \frac{a(r^n - 1)}{r - 1} \quad \text{if } r > 1 \quad \text{or} \quad s_n = \frac{a(1 - r^n)}{1 - r} \quad \text{if } r < 1$$

Examples

1. Find the sum of the first ten terms of the series $8 + 4 + 2 + \dots$

Solution

Here $a=8$, $r=\frac{1}{2}$, $n=10$

$$\begin{aligned} s_{10} &= \frac{8\left(1 - \left(\frac{1}{2}\right)^{10}\right)}{1 - \frac{1}{2}} = \frac{8\left(1 - \frac{1}{2^{10}}\right)}{\frac{1}{2}} \\ &= 16\left(1 - \frac{1}{1024}\right) = 16\left(\frac{1023}{1024}\right) = \frac{1023}{64} = 15.98 \end{aligned}$$

\therefore The sum of the first ten terms of the series is 15.98

The sum to infinity of a G.P

Consider the general G.P, $a + ar + ar^2 + \dots$

$$S_n = \frac{a(r^n - 1)}{r - 1} \quad \text{and if } |r| < 1, \text{ then } \lim_{n \rightarrow \infty} r^n = 0$$

$$\Rightarrow \lim_{n \rightarrow \infty} S_n = \frac{a}{1 - r}$$

Therefore for a G.P the sum to infinity, $S_\infty = \frac{a}{1 - r}$

Example 1

Find the sum to infinity of the following G.P $8, 4, 2, 1, \frac{1}{2}, \dots$

Solution

$$a = 8$$

$$r = \frac{4}{8} = \frac{1}{2}$$

$$S_\infty = \frac{a}{1 - r} = \frac{8}{1 - \frac{1}{2}} = 8 \div \frac{1}{2} = 16$$

Example 2

Find the sum to infinity of the following G.P; $1 - \frac{1}{4} + \frac{1}{16} - \frac{1}{64} + \dots$

Solution

$$a = 1$$

$$r = -\frac{1}{4} \div 1 = -\frac{1}{4}$$

$$S_\infty = \frac{a}{1 - r} = \frac{1}{1 - (-\frac{1}{4})} = 1 \div \frac{5}{4} = \frac{4}{5}$$

Trial questions

1. Find the number of terms in each of the following A.P s

(a) $5 + 8 + 11 + 14 + \dots + 52 + 62$

- (b) $1 + 6 + 11 + \dots + 501 + 506$ [Ans: (a) 20 (b) 102]
2. Find the sum to infinity of the series
- (a) $16 + 12 + 9 + \dots$
- (b) $16 + 8 + 4 + 2 + 1 + \dots$
- (c) $84 - 42 + 21 - 10\frac{1}{2} + \dots$ [Ans: (a) 64 (b) 32 (c) 56]
3. Find the sum of each of the following A.P s
- (a) $2 + 4 + 6 + 8 + 10 + \dots + 146$
- (b) $100 + 95 + 90 + 85 + 80 + \dots - 20$
- (c) $4 + 10 + 16 + 22 + 28 + \dots + 334$
- [Ans: (a) 5402 (b) 1000 (c) 9464]
4. The 5th term of an arithmetic progression is 12 and the sum of the first 5 terms is 80. Determine the 1st term and common difference. [Ans: $a=20, d=-2$]
5. What is the number of terms of a geometric progression 5, 10, 20..... that can give a sum equal to 500,000? [Ans: 17]
6. The 10th term of an arithmetic progression is 29 and the 15th term is 44. Find the value of the first term and the common difference, hence find the sum of the first 60 terms. (Ans: 5430)
7. The 8th term of an AP is twice the third term and the sum of the first eight terms is 39. Find the sum of the first 21 terms of the AP [Ans: 204.5]
8. Five numbers are in a geometric progression, the first being 8 and the last 648. Find the common ratio [Ans; $r=3$]
9. How many terms of the GP $3 + 5 + 8\frac{1}{3} + \dots$ must be taken for the sum to exceed 100? [Ans; $n=7$]
10. In an AP, the 18th term is twice the 9th term. Find the ratio of the sum of 18 terms to the sum of 9 terms of this AP. [Ans: 19:5]
11. An AP has 37 terms of which 9 is the fourth and $58\frac{1}{2}$ is the last. Find the sum of the AP. [Ans: $1165\frac{1}{2}$]
12. If $3\frac{5}{9}$ and $40\frac{1}{2}$ are the first and last terms of a GP respectively and that there are seven terms altogether, find the second term [Ans: $\frac{16}{3}$]
13. The sum of the first twenty terms of an AP is 800. Given that the sum of the first twenty six terms is 1352, determine (i) the first term and common difference (ii) the 23rd term [Ans: 4, 2, 90]
14. The first and last terms of an AP are -3 and 58 respectively. The sum of all the terms of the progression is 5060. Find the number of terms and the common difference. [Ans : $184, \frac{1}{3}$]
15. The first term of an AP is 15 and the fourth term is six. Find the 10th term and the sum of the first 10 terms [Ans: -3, -12, 15]
16. The series of an AP a_1, a_2 and a_3 sum up to 12. The sixth term a_6 is 16. Determine the sum of the first 10 terms of the progression. [Ans; $S_{10} = 145$]
17. The first two terms of an AP and a GP are alike. The first term of each progression is 20. The sum of the first five terms of the AP is 80. Find the common difference of the AP and the common ratio of the GP, hence find the difference between the five terms [Ans: $d=-2, r=0.9$]

18. The sum of the first 12 terms of an AP is 72 .The eighth term is four times the sum of the fourth and fifth terms .Determine (i) the first term and the common difference of the AP (ii) the sum of the first 20 terms

[Ans: -4, 28, -200]

19. The sum of the second and third terms of a GP is 48. The sum of the fifth and sixth terms is 1296.Find (i)the common ratio and the first term of the GP (ii) the sum of the first twelve terms of the GP

[Ans: $r=3$, $a=4$, $S_{12}=1062880$]

20. The first, third and eleventh terms of an AP are also the first second and third terms of a GP.Given that the first term of the AP is 2, find the (i) common ratio, r and common difference, d (ii) the sum of the first 10 terms of the AP (iii) number of terms of a GP that give a total of 699050 [Ans: $d=3$, $r=4$, $S_{10}=155$, $n=10$]

21. The first two terms of an AP are 4 and -8 .Find the number of terms whose sum is -156.

[Ans: $n=10$]

22. Given that 4 and -8 are the first two terms of a GP , find the fifth term and the sum of the first five terms [Ans: $U_5=64$, $S_5=44$]

CHAPTER 5: DIFFERENTIATION

Differentiation is the process of obtaining the gradient of the curve. The gradient function $\frac{dy}{dx}$ (pronounced as “dee y dee x”) or the differential coefficient of y with respect to x

The form ax^n

If $y = ax^n$, then $\frac{dy}{dx} = nax^{n-1}$ where a is a constant

(Multiply the power and then decrease the power by one)

Example

Differentiate the following with respect to x

(i) $y = x^8$ (ii) $y = 3x^5$ (iii) $y = \frac{3}{x^2}$ (iv) $y = \sqrt{x}$

Solution

(i) If $y = x^8$ then $\frac{dy}{dx} = 8x^7$

(ii) If $y = 3x^5$ then $\frac{dy}{dx} = 5 \times 3x^4 = 15x^4$

(iii) $y = 3x^{-2}$

Then $\frac{dy}{dx} = 3 \times -2x^{-2-1} = -6x^{-3} = -\frac{6}{x^3}$

(iv) $y = x^{\frac{1}{2}}$

$\frac{dy}{dx} = \frac{1}{2}x^{\frac{1}{2}-1} = \frac{1}{2}x^{-\frac{1}{2}} = \frac{1}{2x^{\frac{1}{2}}} = \frac{1}{2\sqrt{x}}$

Differentiating a constant (k)

If $y=k$ and k is a constant, $\frac{dy}{dx} = 0$

⇒ The derivative of a constant is zero

If $y = 6$, then $\frac{dy}{dx} = 0$

Differentiating a sum or difference

When differentiating a sum or difference, we differentiate separately i.e.

if $y = f(x) + g(x) - h(x)$

$$\begin{aligned} \frac{dy}{dx} &= \frac{d}{dx}(f(x)) + \frac{d}{dx}(g(x)) - \frac{d}{dx}(h(x)) \\ &= f'(x) + g'(x) - h'(x) \end{aligned}$$

Example

If $y = 3x^2 - 6x + \frac{2}{x^2}$

$= 3x^2 - 6x + 2x^{-2}$

$\frac{dy}{dx} = 6x - 6 - 4x^{-3} = 6x - 6 - \frac{4}{x^3}$

If $y = x^2 + 7x - 2$

$\frac{dy}{dx} = 2x + 7$

If $y = ax^2 + bx + c$, then $\frac{dy}{dx} = 2ax + b$

Gradient of a function / curve

The gradient of a curve is not a constant there for the gradient of a curve is determined at a particular point so the gradient of the curve at any point is defined as the gradient of the tangent to the curve at that point and measures the rate of increase of y with respect to x .

The gradient of the curve at a point is equal to the gradient of the tangent at that same point

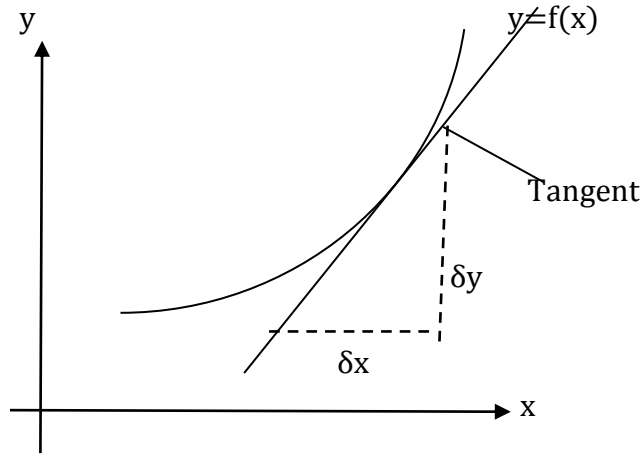

$$\text{Gradient of tangent} = \frac{\delta y}{\delta x} \approx \frac{dy}{dx}$$

Therefore the gradient of the tangent to the curve $y = f(x)$ is given by $\frac{dy}{dx}$ or $f'(x)$

Example 1

Find the gradient of the curve $y = x^3 + x^2 - 2x$

Solution

$$\frac{dy}{dx} = 3x^2 + 2x - 2$$

\therefore the gradient of the curve is $3x^2 + 2x - 2$

Example 2

Find the gradient of the curve $y = 2x^2 - 5$ at a point at the point $(1, -2)$

Solution

$$\frac{dy}{dx} = 4x$$

At a point $(1, -2)$, $x = 1$

$$\frac{dy}{dx} = 4 \times 1 = 4$$

\therefore The gradient of the curve is 4

Example 3

The curve $y = ax^3 - 2x^2 - x + 7$ has a gradient of 3 at the point where $x = 2$. Determine the value of a

Solution

$$\text{Gradient of a curve} = \frac{dy}{dx} = 3ax^2 - 4x - 1$$

$$\text{At } x = 2, \text{ gradient} = 3 \Rightarrow 3a(2)^2 - 4(2) - 1 = 3$$

$$12a - 9 = 3$$

$$12a = 12 \Rightarrow a = 1$$

Equation of the tangent to the curve at a point

When given a point on a certain curve, the equation of the tangent at that point can be obtained.

Example

Find the equation of the tangent to the curve $y = x^3 - 3x + 2$ at the point where $x = 2$

Solution

Gradient of the tangent $= \frac{dy}{dx} = 3x^2 - 3$

When $x = 2$, $\frac{dy}{dx} = 3(2)^2 - 3 = 9$ and $y = 2^3 - 3(2) + 2 = 4$

The equation of the tangent can be obtained from;

$$\frac{y - 4}{x - 2} = 9$$

$$y - 4 = 9x - 18$$

$y = 9x - 14$ is the equation of the tangent to the curve.

Example 2

Find the equation of the tangent to the curve $4y = x^2$ at a point $(2, 1)$

Solution

$$y = \frac{x^2}{4}$$

$\frac{dy}{dx} = \frac{x}{2}$ At $(2, 1)$, $x = 2$ hence $\frac{dy}{dx} = \frac{2}{2} = 1$

Gradient of tangent = 1

$$\frac{y-1}{x-2} = 1$$

$$y - 1 = x - 2$$

$y = x - 1$ is the equation of the tangent to the curve

Normal

A line perpendicular to a tangent at the given point of contact on the curve is called the normal at that point.

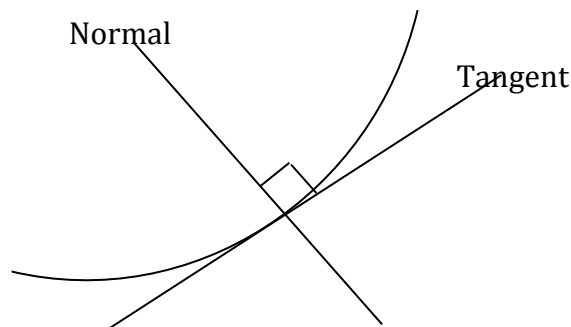

If the gradient of the tangent is m , then the gradient of the normal is $\frac{-1}{m}$ (recall from gradient of perpendicular lines). In other words the product of the gradients of perpendicular lines is -1

Gradient of tangent \times gradient of normal $= -1$

$$\text{Gradient of tangent} = \frac{dy}{dx}, \quad \text{Gradient of normal} = -\frac{1}{\frac{dy}{dx}} = \frac{-1}{\text{gradient of tangent}}$$

Example 1

Find the equation of the normal to the curve $y = 4x - x^2$ at the point where $x = 1$

Solution

$$\frac{dy}{dx} = 4 - 2x$$

At $x=1$, $\frac{dy}{dx} = 4 - 2(1) = 2$ and $y = 4(1) - 1^2 = 3$

Gradient of tangent = 2, Gradient of normal = $\frac{-1}{2}$ at a point (1, 3)

The equation of the normal is thus given by;

$$\frac{y-3}{x-1} = \frac{-1}{2}$$

$$2(y - 3) = -1(x - 1)$$

$$2y - 6 = -x + 1$$

$\therefore 2y + x = 7$ is the equation of normal to the curve

Example 2

Find the equation of the tangent and normal to the curve $y = x^2 - 4x + 1$ at the point (-2, 13)

Solution

$$y = x^2 - 4x + 1$$

$$\frac{dy}{dx} = 2x - 4$$

At (-2, 13), $\frac{dy}{dx} = 2(-2) - 4 = -8$

Thus gradient of the tangent is -8

Equation of tangent is given by; $\frac{y-13}{x+2} = -8 \Rightarrow y - 13 = -8(x + 2)$

$$y = -8x - 3$$

Gradient of the normal = $\frac{-1}{-8} = \frac{1}{8}$

Equation of normal is given by; $\frac{y-13}{x+2} = \frac{1}{8} \Rightarrow 8(y - 13) = x + 2$

$$8y = x + 106$$

Second derivative

We can repeat the differentiation process to obtain the second derivative which is written as $\frac{d^2y}{dx^2}$ or if $y = f(x)$ it is written as $f''(x)$

Example 1

Find $\frac{d^2y}{dx^2}$ if $y = 3x^3 - 6x + 4$

Solution

$$\frac{dy}{dx} = 9x^2 - 6$$

$$\frac{d^2y}{dx^2} = 18x$$

Example 2

Find $\frac{d^2y}{dx^2}$ if $y = 3x^2 + 45x - 75 - x^3$

Solution

$$\frac{dy}{dx} = 6x + 45 - 3x^2$$

$$\frac{d^2y}{dx^2} = 6 - 6x$$

Techniques of differentiation

Examples

Differentiate with respect to (w.r.t) x

(a) $(2x - 1)^2$ (b) $(3x - 1)(2x + 4)$ (c) $\frac{3x^4 + 2x^2 - 1}{2x^2}$

Solution

(a) Let $y = (2x - 1)^2$
 $y = (2x - 1)(2x - 1) = 4x^2 - 4x + 1$
 $\frac{dy}{dx} = 8x - 4$

(b) Let $y = (3x - 1)(2x + 4)$
 $y = 6x^2 + 10x - 4$
 $\frac{dy}{dx} = 12x + 10$

(c) Let $y = \frac{3x^4 + 2x^2 - 1}{2x^2}$
 $= \frac{3x^4}{2x^2} + \frac{2x^2}{2x^2} - \frac{1}{2x^2} = \frac{1}{2}x^2 + 1 - \frac{1}{2}x^{-2}$
 $\frac{dy}{dx} = 3x + x^{-3} = 3x + \frac{1}{x^3}$

Applications of differentiation

Stationary points

A point on a curve at which $\frac{dy}{dx} = 0$ is called a stationary point. At such point, the tangent to the curve is parallel to the x-axis. Stationary points can be maximum or minimum.

Example

Find the stationary points of the curve $y = 4x^3 + 15x^2 - 18x + 7$

Solution

$$\frac{dy}{dx} = 12x^2 + 30x - 18$$

For stationary values $\frac{dy}{dx} = 0 \Rightarrow 12x^2 + 30x - 18 = 0$

$$2x^2 + 5x - 3 = 0 \quad (\text{On dividing through by 6})$$

$$2x^2 + 2x + 3x - 3 = 0$$

$$(2x - 1)(x + 3) = 0$$

$$\text{Either } x = -3 \text{ or } x = \frac{1}{2}$$

$$\text{When } x = -3, y = 4(-3)^3 + 15(-3)^2 - 18(-3) + 7 = 88$$

$$\text{When } x = \frac{1}{2}, y = 4\left(\frac{1}{2}\right)^3 + 15\left(\frac{1}{2}\right)^2 - 18\left(\frac{1}{2}\right) + 7 = \frac{9}{4}$$

Therefore the stationary points are $(-3, 88)$ and $\left(\frac{1}{2}, \frac{9}{4}\right)$

Maximum and minimum turning points

Consider a curve passing through a stationary point and reaching a maximum value at that point

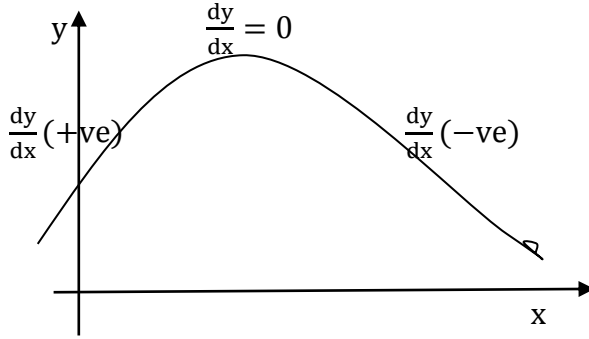

if it reaches a minimum value at a stationary point

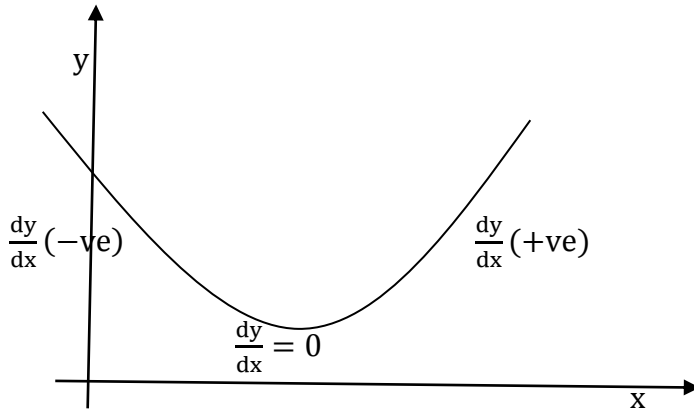

Example

Find the maximum and minimum values of the function $y = 2x^3 - 3x^2 - 12x$

Solution

$$\frac{dy}{dx} = 6x^2 - 6x - 12 = 6(x^2 - x - 2)$$

For maximum or minimum, $\frac{dy}{dx} = 0$

$$\Rightarrow 6(x^2 - x - 2) = 0$$

$$x^2 - x - 2 = 0$$

$$(x - 2)(x + 1) = 0 \Rightarrow x = -1 \text{ or } x = 2$$

Therefore, the turning points are where $x = -1$ and $x = 2$.

The sign of $\frac{dy}{dx}$ is now tested on each side of the turning values of x

X	L	2	R	L	-1	R
sign of $\frac{dy}{dx}$	-	0	+	+	0	-
	\	—	/	/	—	\
	Minimum			Maximum		

Hence at $x = -1$, the function has a maximum value of 7 and when $x = 2$, the function has a minimum value of -20

Second derivative test

The nature of the turning points can be found by using the second derivative test in such a way that if the curve has a maximum turning point then $\frac{d^2y}{dx^2} < 0$ and the curve has a minimum turning point if $\frac{d^2y}{dx^2} > 0$.

Example

Determine the nature of the turning points of the following curves

(a) $y = 15 - 2x^2$ (b) $y = x^2 - 3x + 2$

Solution

(a) $y = 15 - 2x^2$

$$\frac{dy}{dx} = -4x$$

$$\frac{d^2y}{dx^2} = -4 \text{ (Which is less than 0) implying that the curve has a maximum turning point}$$

(b) $y = x^2 - 3x + 2$

$$\frac{dy}{dx} = 2x - 3$$

$$\frac{d^2y}{dx^2} = 2 \text{ (Which is greater than 0) implying that the curve has a minimum turning point.}$$

Curve sketching

For the function $y = f(x)$, we can plot values of x against the corresponding values of y and obtain an accurate graph of the function. A less accurate representation, which we call a sketch, is adequate for many purposes provided that the sketch still shows the salient and noteworthy features of the function. We shall now learn to sketch the curves but we shall mainly concentrate on quadratic curves (in the form $y = ax^2 + bx + c$)

The main guide lines are:-

- Determining the intercepts (where the curve cuts the axes) of the curve i.e. where $y = 0$, $x = 0$
- The position and nature of the turning points ie maximum or minimum turning points

Example 1

Sketch the curve $y = 2x^2 - 6x + 4$

Solution**Intercepts**

When $y = 0$, $2x^2 - 6x + 4 = 0$

$$2x^2 - 2x - 4x + 4 = 0$$

$$(x - 1)(2x - 4) = 0$$

$$x = 1 \text{ or } x = 2$$

(1, 0) and (2, 0) are the intercepts on the x -axis

When $x = 0$, $y = 4$ hence (0, 4) is the intercept on the y -axis

Turning points

$$\frac{dy}{dx} = 4x - 6$$

$$\frac{dy}{dx} = 0$$

$$4x - 6 = 0$$

$$4x = 6$$

$$x = \frac{3}{2}$$

$$y = 2\left(\frac{3}{2}\right)^2 - 6\left(\frac{3}{2}\right) + 4 = -\frac{1}{2}$$

$\therefore \left(\frac{3}{2}, -\frac{1}{2}\right)$ is the turning point

We now investigate for the nature of the turning point of the curve by using the values on the left and right of the turning point

Value of x	L	1.5	R
Sign of $\frac{dy}{dx}$	- ↘	0 —	+ ↗

We now come to realize that (1.5, -0.5) is a minimum turning point .

Alternatively; $\frac{d^2y}{dx^2} = 4$ which is greater than zero ($\frac{d^2y}{dx^2} > 0$); implying that the curve has a minimum turning point.

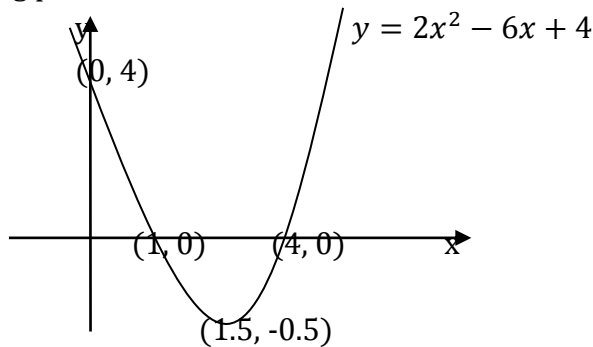

Example 2

Sketch the curve $y = 4x - x^2$

Solution

Intercepts:

$$\text{When } y = 0, 4x - x^2 = 0 \Leftrightarrow x(4 - x) = 0$$

Either $x = 0$ or $x = 4 \Rightarrow (0, 0)$ and $(4, 0)$ is the x - intercepts

When $x = 0, y = 0 \Rightarrow (0, 0)$ is the y - intercept

Turning points:

$$y = 4x - x^2$$

$$\frac{dy}{dx} = 4 - 2x$$

$$4 - 2x = 0 \Rightarrow x = 2$$

When $x = 2, y = 4(2) - 2^2 = 4$

$(2, 4)$ is a turning point

We now investigate for the nature of the turning point of the curve

Value of x	L	2	R
Sign of $\frac{dy}{dx}$	+	0	-
	/	—	\

We now observe that (2, 4) is a maximum turning point

Alternatively; if we would wish to investigate the nature of the turning point using the second derivative, we find out that $\frac{d^2y}{dx^2} = -2$ which is less than zero ($\frac{d^2y}{dx^2} < 0$) hence the curve has a maximum turning point.

We can now sketch the curve

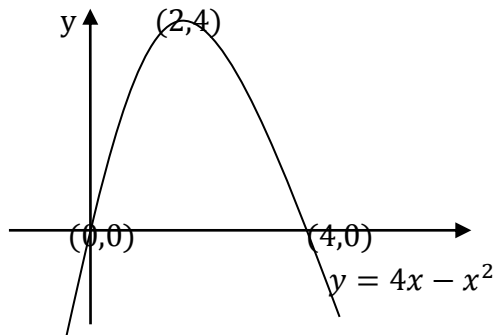

Example 3

Sketch the graph of the function $y = 5 + x - x^2$

Solution

Intercepts:

$$\text{When } y = 0, 5 + x - x^2 = 0$$

$$\Rightarrow (5 - x)(1 + x) = 0$$

$$x = 5 \text{ or } -1$$

\Rightarrow The curve cuts the x-axis at (5, 0) and (-1, 0)

When $x = 0, y = 5$

\Rightarrow The curve cuts the y-axis at (0, 5)

Turning points:

$$y = 5 + x - x^2$$

$$\frac{dy}{dx} = 4 - 2x$$

$$4 - 2x = 0$$

$$x = 2$$

$$y = 5 + 2 - 2^2 = 9 \Rightarrow (2, 9) \text{ is a turning point}$$

$\frac{d^2y}{dx^2} = -2$ which is less than zero ($\frac{d^2y}{dx^2} < 0$) Hence the curve has a maximum turning point.

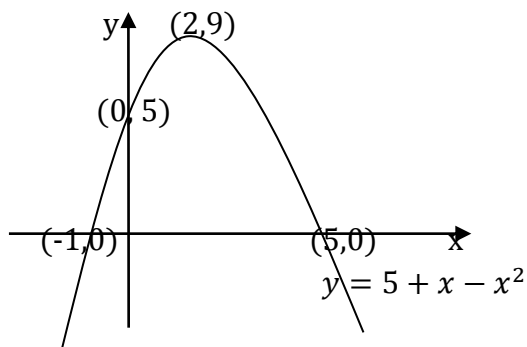

Example 4Sketch the curve $y = x^2 + 2x - 3$ **Solution**

Intercepts:

When $y = 0, x^2 + 2x - 3 = 0$

$$x^2 + 3x - x - 3 = 0$$

$$x(x + 3) - (x + 3) = 0$$

$$(x + 3)(x - 1) = 0$$

$$x = 1 \text{ or } x = -3$$

 $(1, 0)$ and $(-3, 0)$ is where the curve cuts the x-axiswhen $x = 0, y = -3 \Rightarrow (0, -3)$ is where the curve cuts the y-axis

Turning points:

$$y = x^2 + 2x - 3$$

$$\frac{dy}{dx} = 2x + 2$$

$$2x + 2 = 0 \Rightarrow x = -1$$

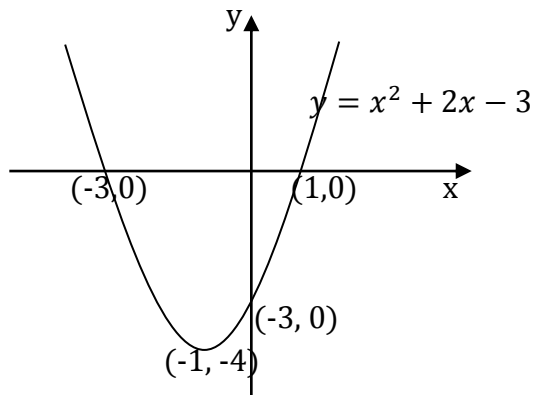
When $x = -1, y = (-1)^2 + 2(-1) - 3 = -4 \Rightarrow (-1, -4)$ is a turning point. $\frac{d^2y}{dx^2} = 4$ which is greater than zero ($\frac{d^2y}{dx^2} > 0$); implying that the curve has a minimum turning point.**Note:**From all the graphs of the functions above, it follows that the curve $y = ax^2 + bx + c$ has a maximum turning point when $a < 0$ and a minimum turning point when $a > 0$ **Velocity and acceleration**If $y = f(x)$, $\frac{dy}{dx}$ is the rate of change of y with respect to x .Similarly if $u = f(v)$, then $\frac{du}{dv}$ is the rate of change of u with respect to v .Now the velocity v of a body is defined as the rate of the displacement s of a body from some fixed origin, with respect to time i.e. $v = \frac{ds}{dt}$ The acceleration a of a body is defined as the rate of the velocity of a body with respect to time i.e. $a = \frac{dv}{dt}$

So displacement, velocity and acceleration are linked up with a process of differentiation with respect to time.

Example 1

The displacement s metres of a body from an origin O at a time t seconds is given by $s = 2t^2 - 3t + 6$. Find (a) the displacement, (b) the velocity (c) the acceleration of the body when $t = 1$.

Solution

$$\text{Given } s = 2t^2 - 3t + 6$$

$$\begin{aligned} \text{(a) When } t = 1, s &= 2(1)^2 - 3(1) + 6 \\ &= 5 \text{ m} \end{aligned}$$

$$\begin{aligned} \text{(b) Since } v &= \frac{ds}{dt} \\ v &= 4t - 3 \end{aligned}$$

$$\text{When } t = 1, v = 4(1) - 3 = 1 \text{ m/s}$$

$$\begin{aligned} \text{(c) Using } a &= \frac{dv}{dt} \\ a &= 4 \text{ m/s}^2 \end{aligned}$$

Example 2

If $v = t^2 - 4t + 3$, find (a) the values of t when the body is at rest (b) the acceleration when $t = 5$.

Solution

$$\begin{aligned} \text{(a) At rest, } v &= 0 \\ t^2 - 4t + 3 &= 0 \\ t^2 - t - 3t + 3 &= 0 \\ (t - 1)(t - 3) &= 0 \\ t &= 1 \text{ or } t = 3 \end{aligned}$$

$$\begin{aligned} \text{(b) Using } a &= \frac{dv}{dt} \\ a &= 2t - 4 \\ \text{when } t = 5, a &= 2(5) - 4 = 6 \text{ m/s}^2 \end{aligned}$$

Example 3

If $s = 5t^3 - t$, find the expressions for v and a in terms of t

Solution

$$\begin{aligned} v &= \frac{ds}{dt} = 15t^2 - 1 \\ a &= \frac{dv}{dt} = 30t \end{aligned}$$

Differentiation of trigonometric functions**Derivatives of $\sin x$ and $\cos x$**

When we differentiate $\sin x$ with respect to x , we get $\cos x$ and if we differentiate $\cos x$ with respect to x we get $-\sin x$. The learner should be in position to recall the above statement.

$$\frac{d}{dx} \sin x = \cos x$$

$$\frac{d}{dx} \cos x = -\sin x$$

Derivatives of $\sin kx$ and $\cos kx$

If we let $y = \sin kx$ and we let $u = kx$ where k is a constant

$$\text{Then } y = \sin u \Rightarrow \frac{dy}{du} = \cos u \text{ and } \frac{du}{dx} = k$$

$$\text{Using the chain rule; } \frac{dy}{dx} = \frac{dy}{du} \times \frac{du}{dx} = k \times \cos u = k \cos kx$$

$$\therefore \frac{d}{dx} \sin kx = k \cos kx$$

Similarly

If we let $y = \cos kx$ and we let $u = kx$ where k is a constant

$$\text{Then } y = \cos u \Rightarrow \frac{dy}{du} = -\sin u \text{ and } \frac{du}{dx} = k$$

$$\text{Using the chain rule; } \frac{dy}{dx} = \frac{dy}{du} \times \frac{du}{dx} = k \times -\sin u = -k \sin kx$$

$$\therefore \frac{d}{dx} \cos kx = -k \sin kx$$

Examples

Find $\frac{dy}{dx}$ if (a) $y = \sin 4x$ (b) $y = \cos 7x$

Solution

Let $y = \sin 4x$ and we let $u = 4x$ where k is a constant

$$\text{Then } y = \sin u \Rightarrow \frac{dy}{du} = \cos u \text{ and } \frac{du}{dx} = 4$$

$$\text{Using the chain rule; } \frac{dy}{dx} = \frac{dy}{du} \times \frac{du}{dx} = 4 \times \cos u = 4 \cos 4x$$

$$\therefore \frac{dy}{dx} = 4 \cos 4x$$

Let $y = \cos 7x$ and we let $u = 7x$ where k is a constant

$$\text{Then } y = \cos u \Rightarrow \frac{dy}{du} = -\sin u \text{ and } \frac{du}{dx} = 7$$

$$\text{Using the chain rule; } \frac{dy}{dx} = \frac{dy}{du} \times \frac{du}{dx} = 7 \times -\sin u = -7 \sin 7x$$

$$\therefore \frac{dy}{dx} = -7 \sin 7x$$

With practice, the reader will soon be able to differentiate such functions directly e.g.

$$\text{if } y = \cos 4x, \frac{dy}{dx} = -\sin 4x \frac{d}{dx}(4x) = -4 \sin 4x$$

$$\text{if } y = \sin 7x, \frac{dy}{dx} = \cos 7x \frac{d}{dx}(7x) = 7 \sin 7x$$

Derivatives of $a \sin kx$, $a \cos kx$, $a \sin kx + c$ and $a \cos kx + c$ (where a , k and c are constants)

$$\frac{d}{dx} a \sin kx = a \frac{d}{dx} \sin kx = ak \cos kx$$

$$\frac{d}{dx} a \cos kx = a \frac{d}{dx} \cos kx = -ak \sin kx$$

$$\frac{d}{dx} [a \sin kx + c] = \frac{d}{dx} a \sin kx + \frac{d}{dx} c = ak \cos kx$$

$$\frac{d}{dx} [a \cos kx + c] = \frac{d}{dx} a \cos kx + \frac{d}{dx} c = -ak \sin kx$$

Examples

Find $\frac{dy}{dx}$ if (a) $y = 5 \sin 9x$ (b) $y = 3 \cos 8x$ (c) $y = 6 \sin 3x + 4$ (d) $y = 3 \cos 2x + 6$

Solution

$$(a) \frac{dy}{dx} = 5 \frac{d}{dx} \sin 9x = 5 \times 9 \cos 9x = 45 \cos 9x$$

$$(b) \frac{dy}{dx} = 3 \frac{d}{dx} \cos 8x = -3 \times 8 \sin 8x = -24 \sin 8x$$

$$(c) \frac{dy}{dx} = \frac{d}{dx} 6 \sin 3x + \frac{d}{dx} 4 = 18 \cos 3x$$

$$(d) \frac{dy}{dx} = \frac{d}{dx} 3 \cos 2x + \frac{d}{dx} 6 = -6 \sin 2x$$

Derivative of $a \sin(kx + c)$ and $a \cos(kx + c)$

If we let $y = a \sin(kx + c)$ and we let $u = kx + c$ where k and c are constants

$$\text{Then } y = a \sin u \Rightarrow \frac{dy}{du} = a \cos u \text{ and } \frac{du}{dx} = k$$

$$\text{Using the chain rule; } \frac{dy}{dx} = \frac{dy}{du} \times \frac{du}{dx} = k \times a \cos u = ak \cos(kx + c)$$

$$\therefore \frac{d}{dx} a \sin(kx + c) = ak \cos(kx + c)$$

Similarly

If we let $y = a \cos(kx + c)$ and we let $u = kx + c$ where k and c are constants

$$\text{Then } y = a \cos u \Rightarrow \frac{dy}{du} = -a \sin u \text{ and } \frac{du}{dx} = k$$

$$\text{Using the chain rule; } \frac{dy}{dx} = \frac{dy}{du} \times \frac{du}{dx} = k \times -a \sin u = -ak \sin(kx + c)$$

$$\therefore \frac{d}{dx} a \cos(kx + c) = -ak \sin(kx + c)$$

Examples

Find $\frac{dy}{dx}$ if (a) $y = 5 \sin(4x + 3)$ (b) $y = 3 \cos(5x + 10)$

Solution

$$(a) \frac{dy}{dx} = 5 \times 4 \cos(4x + 3) = 20 \cos(4x + 3)$$

$$(b) \frac{dy}{dx} = -3 \times 5 \sin(5x + 10) = -15 \sin(5x + 10)$$

Trial questions

1. Differentiate the following with respect to x

$$(a) (3x + 2)^4 \quad [\text{Ans: } 12(3x + 2)^3]$$

$$(b) (3 + x^2)^5 \quad [\text{Ans: } 10x(3 + x^2)^4]$$

$$(c) (1 - x^3)^8 \quad [\text{Ans: } -24x^2(1 - x^3)^7]$$

2. Find the gradient of the curve $y = x^2 + 6x - 4$ at the point where the curve cuts the y -axis

[Ans: 6]

3. Find the equations of the tangent and normal to the following curves at the points indicated

$$(a) y = x^2 \text{ at } (3, 9) \quad [\text{Ans: } y = 6x - 9, 6y + x = 57]$$

$$(b) y = 5 - 2x^2 \text{ at } (-1, 3) \quad [\text{Ans: } y = 4x + 7, 4y + x = 11]$$

$$(c) y = 4 + x - 2x^2 \text{ at a point where } x = 1 \quad [\text{Ans: } y + 3x = 6, 3y = x + 8]$$

4. Find the coordinates of any stationary points on the given curves and distinguish between them

$$(a) y = 2x^2 - 8x \quad [\text{Ans: min at } (2, -8)]$$

$$(b) y = 18x - 20 - 3x^2 \quad [Ans: Max at (3, 7)]$$

$$(c) y = x^3 + 3x^2 - 9x - 5 \quad [Ans: max at (-3, 22), min at (1, -10)]$$

5. Sketch the curves of the given equations, clearly indicating on your sketch the coordinates of any turning points and of any points where the curve cuts the axes.

$$(a) y = (1 - x)(x - 5)$$

$$(b) y = x^2 - 8x - 20$$

$$(c) y = x^2 + 2x - 3$$

$$(d) y = x^2 + 10x + 10$$

$$(e) y = 3x - x^2$$

6. Differentiate the following trigonometric functions with respect to x

$$(a) 7 \sin(8x + 3) \quad [Ans: 56 \cos(8x + 3)]$$

$$(b) 15 \cos(3x + 4) \quad [Ans: -45 \sin(3x + 4)]$$

$$(c) 24 \cos 2x + 3 \quad [Ans: -48 \sin 2x]$$

$$(d) 13 \sin 4x + 3 \quad [Ans: 52 \cos 4x]$$

CHAPTER 6: MATRICES

A matrix is a rectangular array of numbers called elements or entries. Information can conveniently be presented as an array of rows and columns.

Order of a matrix

The order of a matrix gives the format of how a matrix should be written. It is always in the form $m \times n$ where m is the number of rows and n is the number of columns in the matrix. For example

(i) A 2×2 matrix

In this matrix the number of rows is 2 and the columns are also 2 i.e.

$$\begin{pmatrix} 8 & 1 \\ -3 & 4 \end{pmatrix}, \begin{pmatrix} a & b \\ c & d \end{pmatrix}$$

(ii) A 3×3 matrix

In this matrix the number of rows is 3 and the columns are also 3 i.e.

$$\begin{pmatrix} 3 & 1 & 0 \\ 4 & 0 & 1 \\ 1 & 9 & 2 \end{pmatrix}, \begin{pmatrix} a & b & c \\ d & e & f \\ g & h & i \end{pmatrix}$$

Note: Other matrices of different order are possible i.e. $1 \times 2, 2 \times 1, 1 \times 3, 3 \times 1, 2 \times 3, 3 \times 2, e. t. c.$

Operations on matrices**Addition and Subtraction**

Two or more matrices can be added if they have the same order i.e. the number of rows and columns in the first matrix must be equal to the number of rows and columns in the second matrix.

Examples

$$1. \begin{pmatrix} a & b \\ c & d \end{pmatrix} + \begin{pmatrix} e & f \\ g & h \end{pmatrix} = \begin{pmatrix} a+e & b+f \\ c+g & d+h \end{pmatrix}$$

$$2. \begin{pmatrix} -2 & 0 \\ 3 & 2 \end{pmatrix} + \begin{pmatrix} -1 & 3 \\ 0 & 2 \end{pmatrix} = \begin{pmatrix} -2+(-1) & 0+3 \\ 3+0 & 2+2 \end{pmatrix} = \begin{pmatrix} -3 & 3 \\ 3 & 4 \end{pmatrix}$$

$$3. \begin{pmatrix} 1 & 0 & 1 \\ 3 & -1 & 2 \end{pmatrix} + \begin{pmatrix} 3 & 2 & 1 \\ 2 & 0 & -3 \end{pmatrix} = \begin{pmatrix} 1+3 & 0+2 & 1+1 \\ 3+2 & -1+0 & 2+(-3) \end{pmatrix} = \begin{pmatrix} 4 & 2 & 2 \\ 5 & -1 & -1 \end{pmatrix}$$

$$4. \begin{pmatrix} a & b \\ c & d \end{pmatrix} - \begin{pmatrix} e & f \\ g & h \end{pmatrix} = \begin{pmatrix} a-e & b-f \\ c-g & d-h \end{pmatrix}$$

$$5. \begin{pmatrix} 3 & 1 \\ -2 & 0 \end{pmatrix} - \begin{pmatrix} -1 & -3 \\ 0 & 2 \end{pmatrix} = \begin{pmatrix} 3-(-1) & 1-(-3) \\ -2-0 & 0-2 \end{pmatrix} = \begin{pmatrix} 4 & 4 \\ -2 & -2 \end{pmatrix}$$

$$6. \begin{pmatrix} 6 & 3 \\ 1 & 2 \\ 1 & 0 \end{pmatrix} - \begin{pmatrix} 0 & -1 \\ 8 & 1 \\ 3 & 0 \end{pmatrix} = \begin{pmatrix} 6-0 & 3-(-1) \\ 1-8 & 2-1 \\ 1-3 & 0-0 \end{pmatrix} = \begin{pmatrix} 6 & 4 \\ -7 & 3 \\ -2 & 0 \end{pmatrix}$$

Multiplication of matrices**Scalar multiplication**

This is the type of multiplication where we multiply a given matrix with a constant which is taken as a scalar.

Examples

$$1. \text{ Expand } a \begin{pmatrix} b & c \\ e & f \end{pmatrix}$$

Solution

$$a \begin{pmatrix} b & c \\ e & f \end{pmatrix} = \begin{pmatrix} a \times b & a \times c \\ a \times e & a \times f \end{pmatrix} = \begin{pmatrix} ab & ac \\ ae & af \end{pmatrix}$$

2. Given matrix $A = \begin{pmatrix} 3 & 0 \\ 1 & -2 \end{pmatrix}$ and $B = \begin{pmatrix} 0 & 3 \\ -2 & 8 \end{pmatrix}$

Find (i) $2A$ (ii) $4B - A$ (iii) $3(A+B)$

Solution

$$(i) \quad 2A = 2 \begin{pmatrix} 3 & 0 \\ 1 & -2 \end{pmatrix} = \begin{pmatrix} 2 \times 3 & 2 \times 0 \\ 2 \times 1 & 2 \times -2 \end{pmatrix} = \begin{pmatrix} 6 & 0 \\ 2 & -4 \end{pmatrix}$$

$$(ii) \quad 4B = 4 \begin{pmatrix} 0 & 3 \\ -2 & 8 \end{pmatrix} = \begin{pmatrix} 4 \times 0 & 4 \times 3 \\ 4 \times -2 & 4 \times 8 \end{pmatrix} = \begin{pmatrix} 0 & 12 \\ -8 & 32 \end{pmatrix}$$

$$4B - A = \begin{pmatrix} 0 & 12 \\ -8 & 32 \end{pmatrix} - \begin{pmatrix} 3 & 0 \\ 1 & -2 \end{pmatrix} = \begin{pmatrix} -3 & 12 \\ -9 & 34 \end{pmatrix}$$

$$(iii) \quad A + B = \begin{pmatrix} 3 & 0 \\ 1 & -2 \end{pmatrix} + \begin{pmatrix} 0 & 3 \\ -2 & 8 \end{pmatrix} = \begin{pmatrix} 3 & 3 \\ -1 & 6 \end{pmatrix}$$

$$3(A + B) = 3 \begin{pmatrix} 3 & 3 \\ -1 & 6 \end{pmatrix} = \begin{pmatrix} 9 & 9 \\ -3 & 18 \end{pmatrix}$$

General multiplication of matrices

We can multiply two or more matrices if and only if the number of columns in the first matrix are equal to the number of rows in the second matrix.

Examples

Expand

$$(i) \quad \begin{pmatrix} a & b \\ c & d \end{pmatrix} \begin{pmatrix} e & f \\ g & h \end{pmatrix}$$

Solution

$$\begin{pmatrix} a & b \\ c & d \end{pmatrix} \begin{pmatrix} e & f \\ g & h \end{pmatrix} = \begin{pmatrix} a \times e + b \times g & a \times f + b \times h \\ c \times e + d \times g & c \times f + d \times h \end{pmatrix}$$

Hence when we are expanding, we multiply row by column

$$(ii) \quad \begin{pmatrix} 3 & 1 \\ 2 & 1 \end{pmatrix} \begin{pmatrix} 0 & 1 \\ 3 & 1 \end{pmatrix} = \begin{pmatrix} 3 \times 0 + 1 \times 3 & 3 \times 1 + 1 \times 1 \\ 2 \times 0 + 1 \times 3 & 2 \times 1 + 1 \times 1 \end{pmatrix} = \begin{pmatrix} 0 + 3 & 3 + 1 \\ 0 + 3 & 2 + 1 \end{pmatrix} = \begin{pmatrix} 3 & 4 \\ 3 & 3 \end{pmatrix}$$

$$(iii) \quad \begin{pmatrix} 3 & 4 \\ 2 & 5 \end{pmatrix}^2 = \begin{pmatrix} 3 & 4 \\ 2 & 5 \end{pmatrix} \begin{pmatrix} 3 & 4 \\ 2 & 5 \end{pmatrix} = \begin{pmatrix} 3 \times 3 + 4 \times 2 & 3 \times 4 + 4 \times 5 \\ 2 \times 3 + 5 \times 2 & 2 \times 4 + 5 \times 5 \end{pmatrix}$$

$$= \begin{pmatrix} 9 + 8 & 12 + 20 \\ 6 + 10 & 8 + 25 \end{pmatrix} = \begin{pmatrix} 17 & 32 \\ 16 & 33 \end{pmatrix}$$

$$(iv) \quad \text{Multiply } \begin{pmatrix} 8 & 9 \\ 5 & -1 \end{pmatrix} \begin{pmatrix} -2 & 3 \\ 4 & 0 \end{pmatrix}$$

Solution

$$\begin{pmatrix} 8 & 9 \\ 5 & -1 \end{pmatrix} \begin{pmatrix} -2 & 3 \\ 4 & 0 \end{pmatrix} = \begin{pmatrix} 8 \times -2 + 9 \times 4 & 8 \times 3 + 9 \times 0 \\ 5 \times -2 + -1 \times 4 & 5 \times 3 + -1 \times 0 \end{pmatrix}$$

$$= \begin{pmatrix} -16 + 36 & 24 + 0 \\ -10 + -4 & 15 + 0 \end{pmatrix} = \begin{pmatrix} 20 & 24 \\ -14 & 15 \end{pmatrix}$$

(v) Given the matrices below;

$$\mathbf{A} = \begin{pmatrix} a & b \\ c & d \end{pmatrix}, \quad \mathbf{B} = \begin{pmatrix} x \\ y \end{pmatrix}$$

Their matrix product is;

$$\mathbf{AB} = \begin{pmatrix} a & b \\ c & d \end{pmatrix} \begin{pmatrix} x \\ y \end{pmatrix} = \begin{pmatrix} ax + by \\ cx + dy \end{pmatrix}$$

yet \mathbf{BA} is not defined.

(vi) Given the matrices below;

$$\mathbf{A} = \begin{pmatrix} 1 & 2 \\ 3 & 4 \end{pmatrix}, \quad \mathbf{B} = \begin{pmatrix} a & b \\ c & d \end{pmatrix}$$

Their matrix products are:

$$\mathbf{AB} = \begin{pmatrix} 1 & 2 \\ 3 & 4 \end{pmatrix} \begin{pmatrix} a & b \\ c & d \end{pmatrix} = \begin{pmatrix} 1 \times a + 2 \times c & 1 \times b + 2 \times d \\ 3 \times a + 4 \times c & 3 \times b + 4 \times d \end{pmatrix} = \begin{pmatrix} a + 2c & b + 2d \\ 3a + 4c & 3b + 4d \end{pmatrix}$$

$$\mathbf{BA} = \begin{pmatrix} a & b \\ c & d \end{pmatrix} \begin{pmatrix} 1 & 2 \\ 3 & 4 \end{pmatrix} = \begin{pmatrix} a \times 1 + b \times 3 & a \times 2 + b \times 4 \\ c \times 1 + d \times 3 & c \times 2 + d \times 4 \end{pmatrix} = \begin{pmatrix} a + 3b & 2a + 4b \\ c + 3d & 2c + 4d \end{pmatrix}.$$

Note: In general, when multiplying matrices, the commutative law doesn't hold, i.e. $AB \neq BA$ as seen in the above example.

The determinant of a matrix

Consider a matrix $A = \begin{pmatrix} a & b \\ c & d \end{pmatrix}$, the determinant is denoted by $\det A$ where $\det A = ad - bc$. The matrix which has a determinant of zero is called a singular matrix

Examples

1. If $M = \begin{pmatrix} 4 & 1 \\ 3 & -1 \end{pmatrix}$, Find $\det M$

Solution

$$\det M = (4 \times -1) - (1 \times 3) = -4 - 3 = -7$$

2. If $A = \begin{pmatrix} 1 & 3 \\ 1 & 0 \end{pmatrix}$, find $\det A$

solution

$$\det A = (1 \times 0) - (3 \times 1) = 0 - 3 = -3$$

3. Given that $A = \begin{pmatrix} 1 & 3 \\ 1 & 0 \end{pmatrix}$, $B = \begin{pmatrix} 3 & 2 \\ 1 & 1 \end{pmatrix}$, Find (i) $\det(3A + B)$ (ii) $\det(2A - B)$

Solution

$$(i) \quad 3A + B = 3\begin{pmatrix} 1 & 3 \\ 1 & 0 \end{pmatrix} + \begin{pmatrix} 3 & 2 \\ 1 & 1 \end{pmatrix} = \begin{pmatrix} 3 & 9 \\ 3 & 0 \end{pmatrix} + \begin{pmatrix} 3 & 2 \\ 1 & 1 \end{pmatrix} = \begin{pmatrix} 6 & 11 \\ 4 & 1 \end{pmatrix}$$

$$\det(3A + B) = (6 \times 1) - (11 \times 4) = 6 - 44 = -38$$

$$(ii) \quad (2A - B) = 2\begin{pmatrix} 1 & 3 \\ 1 & 0 \end{pmatrix} - \begin{pmatrix} 3 & 2 \\ 1 & 1 \end{pmatrix} = \begin{pmatrix} 2 & 6 \\ 2 & 0 \end{pmatrix} - \begin{pmatrix} 3 & 2 \\ 1 & 1 \end{pmatrix} = \begin{pmatrix} -1 & 4 \\ 1 & -1 \end{pmatrix}$$

4. Given that $A = \begin{pmatrix} 4 & 6 \\ 1 & 1 \end{pmatrix}$ and $B = \begin{pmatrix} -1 & -4 \\ 2 & 1 \end{pmatrix}$. Show that $A + B$ is a singular matrix.

Solution

$$A + B = \begin{pmatrix} 4 & 6 \\ 1 & 1 \end{pmatrix} + \begin{pmatrix} -1 & -4 \\ 2 & 1 \end{pmatrix} = \begin{pmatrix} 3 & 2 \\ 3 & 2 \end{pmatrix}$$

$$\det(A + B) = 3 \times 2 - 2 \times 3 = 6 - 6 = 0$$

Since $\det(A + B) = 0$, $A + B$ is a singular matrix

Formation of a matrix

When forming matrices, we consider the number of rows as well as the number of columns required for a certain matrix.

Examples

- (i) A 3×1 matrix

$$\begin{pmatrix} 2 \\ 0 \\ 1 \end{pmatrix}$$

- (ii) A 2×2 matrix

$$\begin{pmatrix} 4 & 2 \\ 0 & 3 \end{pmatrix}$$

- (iii) A 4×3 matrix

$$\begin{pmatrix} 6 & 0 & 7 \\ 2 & 1 & 2 \\ 4 & 5 & 8 \\ -2 & 9 & 1 \end{pmatrix}$$

Inverse of a matrix

The inverse of a matrix A is given by $\frac{1}{\det A} \times \text{the adjoint matrix}$. The inverse of a matrix A is denoted by A^{-1} . To get the adjoint, we interchange the entries of the major diagonal and multiply the entries of the minor diagonal by -1 i.e.

$$\text{If } A = \begin{pmatrix} a & b \\ c & d \end{pmatrix}, \text{ Adjoint } A = \begin{pmatrix} d & -b \\ -c & a \end{pmatrix}$$

$$\det A = ad - bc$$

$$A^{-1} = \frac{1}{\det A} \times \text{Adjoint } A$$

$$A^{-1} = \frac{1}{ad-bc} \begin{pmatrix} d & -b \\ -c & a \end{pmatrix}$$

Note: The inverse of a singular matrix does not exist because we end up with a division by zero which is undefined.

Examples

If $A = \begin{pmatrix} 3 & 1 \\ 0 & 1 \end{pmatrix}$, $B = \begin{pmatrix} -1 & 2 \\ 1 & 3 \end{pmatrix}$, find (i) A^{-1} (ii) B^{-1} (iii) $(A + B)^{-1}$

Solution

(i) $\text{Det } A = (3 \times 1) - (1 \times 0) = 3$

Adjoint $A = \begin{pmatrix} 1 & -1 \\ 0 & 3 \end{pmatrix}$

$$A^{-1} = \frac{1}{3} \begin{pmatrix} 1 & -1 \\ 0 & 3 \end{pmatrix}$$

(ii) $\text{Det } B = (-1 \times 3) - (2 \times 1) = -3 - 2 = -5$

Adjoint $B = \begin{pmatrix} 3 & -2 \\ -1 & -1 \end{pmatrix}$

$$B^{-1} = \frac{1}{-5} \begin{pmatrix} 3 & -2 \\ -1 & -1 \end{pmatrix}$$

(iii) $A + B = \begin{pmatrix} 3 & 1 \\ 0 & 1 \end{pmatrix} + \begin{pmatrix} -1 & 2 \\ 1 & 3 \end{pmatrix} = \begin{pmatrix} 2 & 3 \\ 1 & 4 \end{pmatrix}$

$\text{Det } (A + B) = (2 \times 4) - (3 \times 1) = 8 - 3 = 5$

Adjoint $(A + B) = \begin{pmatrix} 4 & -3 \\ -1 & 2 \end{pmatrix}$

$$(A + B)^{-1} = \frac{1}{5} \begin{pmatrix} 4 & -3 \\ -1 & 2 \end{pmatrix}$$

Note: $AA^{-1} = I$ where I is an identity matrix where an identity matrix which has the entries in the major diagonal equal to one and the entries in the minor diagonal all equal to zero e.g.

$$\begin{pmatrix} 1 & 0 \\ 0 & 1 \end{pmatrix}, \text{ is } 2 \times 2 \text{ identity matrix.}$$

Solving simultaneous equations using matrices

One of the most important applications of matrices is to find the solution of linear simultaneous equations. It is a requirement to first re-arrange the given simultaneous equations into matrix format.

Example 1

Consider the simultaneous equations

$$x + 2y = 4$$

$$3x - 5y = 1$$

Provided you understand how matrices are multiplied together you will realise that these can be written in matrix form as;

$$\begin{pmatrix} 1 & 2 \\ 3 & -5 \end{pmatrix} \begin{pmatrix} x \\ y \end{pmatrix} = \begin{pmatrix} 4 \\ 1 \end{pmatrix}$$

Writing

$$A = \begin{pmatrix} 1 & 2 \\ 3 & -5 \end{pmatrix}, X = \begin{pmatrix} x \\ y \end{pmatrix} \text{ and } B = \begin{pmatrix} 4 \\ 1 \end{pmatrix},$$

We have $AX = B$

This is the **matrix form** of the simultaneous equations. Here the unknown is the matrix X , since A and B are already known. A is called the **matrix of coefficients**.

Now given $AX = B$, we can multiply both sides by the inverse of A , provided this exists, to give;

$$A^{-1}AX = A^{-1}B$$

But $AA^{-1} = I$, the identity matrix. Furthermore, $IX = X$, because multiplying any matrix by an identity matrix of the appropriate size leaves the matrix unaltered. So $X = A^{-1}B$

Thus if $AX = B$ then $X = A^{-1}B$

This result gives us a method for solving simultaneous equations. All we need do is write them in matrix form, calculate the inverse of the matrix of coefficients, and finally perform a matrix multiplication.

Solution to the above question

$$\begin{pmatrix} 1 & 2 \\ 3 & -5 \end{pmatrix} \begin{pmatrix} x \\ y \end{pmatrix} = \begin{pmatrix} 4 \\ 1 \end{pmatrix}$$

We need to calculate the inverse of $A = \begin{pmatrix} 1 & 2 \\ 3 & -5 \end{pmatrix}$

$$\text{Det } A = (1 \times -5) - (2 \times 3) = -11$$

$$A^{-1} = -\frac{1}{11} \begin{pmatrix} -5 & -2 \\ -3 & 1 \end{pmatrix}$$

$$\begin{aligned} X = A^{-1}B &= -\frac{1}{11} \begin{pmatrix} -5 & -2 \\ -3 & 1 \end{pmatrix} \begin{pmatrix} 4 \\ 1 \end{pmatrix} \\ &= -\frac{1}{11} \begin{pmatrix} -5 \times 4 + -2 \times 1 \\ -3 \times 4 + 1 \times 1 \end{pmatrix} = -\frac{1}{11} \begin{pmatrix} -22 \\ -11 \end{pmatrix} = \begin{pmatrix} 2 \\ 1 \end{pmatrix} \\ \begin{pmatrix} x \\ y \end{pmatrix} &= \begin{pmatrix} 2 \\ 1 \end{pmatrix} \Rightarrow x = 2 \text{ and } y = 1 \end{aligned}$$

Example 2:

Using matrices, calculate the values of x and y for the following simultaneous equations:

$$2x - 2y - 3 = 0$$

$$8y = 7x + 2$$

Solution:

Step 1: Write the equations in the form $ax + by = c$

$$2x - 2y - 3 = 0 \Rightarrow 2x - 2y = 3$$

$$8y = 7x + 2 \Rightarrow 7x - 8y = -2$$

Step 2: Write the equations in matrix form.

$$\begin{array}{l} \text{coefficients of first equation} \rightarrow \\ \text{coefficients of second equation} \rightarrow \end{array} \begin{pmatrix} 2 & -2 \\ 7 & -8 \end{pmatrix} \begin{pmatrix} x \\ y \end{pmatrix} = \begin{pmatrix} 3 \\ -2 \end{pmatrix} \begin{array}{l} \leftarrow \text{constant of first equation} \\ \leftarrow \text{constant of second equation} \end{array}$$

Step 3: Find the inverse of the 2×2 matrix.

$$\text{Determinant} = (2 \times -8) - (-2 \times 7) = -2$$

$$\text{Inverse} = -\frac{1}{2} \begin{pmatrix} -8 & 2 \\ -7 & 2 \end{pmatrix} = \begin{pmatrix} 4 & -1 \\ 3.5 & -1 \end{pmatrix}$$

Step 4: Multiply both sides of the matrix equations with the inverse

$$\begin{pmatrix} 4 & -1 \\ 3.5 & -1 \end{pmatrix} \begin{pmatrix} 2 & -2 \\ 7 & -8 \end{pmatrix} \begin{pmatrix} x \\ y \end{pmatrix} = \begin{pmatrix} 4 & -1 \\ 3.5 & -1 \end{pmatrix} \begin{pmatrix} 3 \\ -2 \end{pmatrix}$$

$$\begin{pmatrix} 1 & 0 \\ 0 & 1 \end{pmatrix} \begin{pmatrix} x \\ y \end{pmatrix} = \begin{pmatrix} 14 \\ 12.5 \end{pmatrix}$$

So, $x = 14$ and $y = 12.5$

Example 3

Solve the simultaneous equations below using the matrix method

$$x + 2y = 4$$

$$x + y = 3$$

Solution

$$\begin{pmatrix} 1 & 2 \\ 1 & 1 \end{pmatrix} \begin{pmatrix} x \\ y \end{pmatrix} = \begin{pmatrix} 4 \\ 3 \end{pmatrix}$$

$$\text{Let } A = \begin{pmatrix} 1 & 2 \\ 1 & 1 \end{pmatrix}, B = \begin{pmatrix} x \\ y \end{pmatrix} \text{ and } C = \begin{pmatrix} 4 \\ 3 \end{pmatrix}$$

$$\text{Now } AB = C \Rightarrow B = \frac{C}{A}$$

$$B = A^{-1}C$$

$$\text{Det } A = (1 \times 1) - (2 \times 1) = -1$$

$$A^{-1} = \frac{1}{-1} \begin{pmatrix} 1 & -2 \\ -1 & 1 \end{pmatrix} = \begin{pmatrix} -1 & 2 \\ 1 & -1 \end{pmatrix}$$

But from $B = A^{-1}C$

$$\begin{pmatrix} x \\ y \end{pmatrix} = \begin{pmatrix} -1 & 2 \\ 1 & -1 \end{pmatrix} \begin{pmatrix} 4 \\ 3 \end{pmatrix}$$

$$\begin{pmatrix} x \\ y \end{pmatrix} = \begin{pmatrix} -1 \times 4 + 2 \times 3 \\ 1 \times 4 + -1 \times 3 \end{pmatrix} = \begin{pmatrix} -4 + 6 \\ 4 + -3 \end{pmatrix} = \begin{pmatrix} 2 \\ 1 \end{pmatrix}$$

From equality of matrices $x = 2$ and $y = 1$

Example 4

Solve the simultaneous equations using the matrix method

$$2x + y = 3$$

$$4x - 2y = 10$$

Solution

$$\begin{pmatrix} 2 & 1 \\ 4 & -2 \end{pmatrix} \begin{pmatrix} x \\ y \end{pmatrix} = \begin{pmatrix} 3 \\ 10 \end{pmatrix}$$

$$\text{Let } A = \begin{pmatrix} 2 & 1 \\ 4 & -2 \end{pmatrix}$$

$$\text{Det } A = (2 \times -2) - (1 \times 4) = -8$$

$$A^{-1} = \frac{1}{\text{det } A} \times \text{Adjoint } A$$

$$= \frac{1}{-8} \begin{pmatrix} -2 & -1 \\ -4 & 2 \end{pmatrix}$$

$$\begin{pmatrix} x \\ y \end{pmatrix} = -\frac{1}{8} \begin{pmatrix} -2 & -1 \\ -4 & 2 \end{pmatrix} \begin{pmatrix} 3 \\ 10 \end{pmatrix}$$

$$\begin{pmatrix} x \\ y \end{pmatrix} = -\frac{1}{8} \begin{pmatrix} -2 \times 3 + -1 \times 10 \\ -4 \times 3 + 2 \times 10 \end{pmatrix} = -\frac{1}{8} \begin{pmatrix} -16 \\ 8 \end{pmatrix} = \begin{pmatrix} 2 \\ -1 \end{pmatrix}$$

$$x = 2 \text{ and } y = -1$$

Trial questions

1. Solve the following sets of simultaneous equations using the inverse matrix method.

a) $5x + y = 13$

$$3x + 2y = 5$$

b) $3x + 2y = -2$

$x + 4y = 6$

c) $4x + 2y = 6$

$3x + 5y = 5$

d) $7x + 4 = 5y$

$4 - 2x + y = 0$

[Ans: a) $x = 3, y = -2$, b) $x = -2, y = 2$ c) $x = 10/7, y = 1/7$ d) $x = 8, y = 12$]2. Given the matrices $A = \begin{pmatrix} 1 & 0 \\ 4 & 5 \end{pmatrix}$ and $B = \begin{pmatrix} 6 & -1 \\ -2 & -3 \end{pmatrix}$, find;(i) Matrix C which is equal to $2A - 3B$ (ii) AB (iii) Show that $\text{Det}(A.B) = (\text{Det} A)(\text{Det} B)$ [Ans: (i) $\begin{pmatrix} -16 & 3 \\ 14 & 9 \end{pmatrix}$ (ii) $\begin{pmatrix} 6 & -1 \\ 14 & -19 \end{pmatrix}$]3. Given that $A = \begin{pmatrix} 3 & 0 \\ 1 & -2 \end{pmatrix}$ and $B = \begin{pmatrix} 1 & 2 \\ 5 & 0 \end{pmatrix}$, determine (i) $A + B$ (ii) $(AB)^2$ [Ans: (i) $\begin{pmatrix} 4 & 2 \\ 6 & -2 \end{pmatrix}$ (ii) $\begin{pmatrix} -45 & 30 \\ -45 & -50 \end{pmatrix}$]5. Given that $\begin{pmatrix} 3-a & 3 \\ -1 & -2 \end{pmatrix} \begin{pmatrix} -3 \\ x \end{pmatrix} = \begin{pmatrix} -3 \\ x \end{pmatrix}$, Find the values of a and x [Ans: $a = 1, x = 1$]6. Given the matrix $m = \begin{pmatrix} 3a & a-6 \\ -6 & a+2 \end{pmatrix}$, find the values of a for which the matrix m is singular[Ans: $a = -5.61, 1.61$]7. Given that $A = \begin{pmatrix} 1 & 2 \\ -2 & 1 \end{pmatrix}$; $B = \begin{pmatrix} 2 & -1 \\ -1 & 2 \end{pmatrix}$, find $AB - BA$ [Ans: $\begin{pmatrix} -4 & 0 \\ 0 & 4 \end{pmatrix}$]8. A and B are two matrices such that $A = \begin{pmatrix} 1 & 3 \\ 4 & 11 \end{pmatrix}$ and $B = \begin{pmatrix} -1 & 2 \\ 1 & 3 \end{pmatrix}$, Find (i) matrix $P = AB$ (ii) P^{-1} [Ans : (i) $\begin{pmatrix} 2 & 11 \\ 7 & 41 \end{pmatrix}$ (ii) $-\frac{1}{5} \begin{pmatrix} 41 & -11 \\ -7 & 2 \end{pmatrix}$]9. Given the matrices $P = \begin{pmatrix} 2 & -2 \\ 0 & 1 \end{pmatrix}$, $Q = \begin{pmatrix} 3 & 2 \\ 4 & -1 \end{pmatrix}$ and $R = \begin{pmatrix} 5 & -4 \\ -1 & 2 \end{pmatrix}$; determine(i) $P.Q + R$ (ii) the determinant $(P.Q + R)$ [Ans: (i) $\begin{pmatrix} 3 & 2 \\ 3 & 1 \end{pmatrix}$ (ii) -3]9. Find the inverse of $A = \begin{pmatrix} 4 & -1 \\ 2 & 3 \end{pmatrix}$ [Ans: $\frac{1}{14} \begin{pmatrix} 3 & 1 \\ -2 & 4 \end{pmatrix}$]10. Given that $A = \begin{pmatrix} 1 & 2 \\ 2 & 3 \end{pmatrix}$, show that $A^2 - 4A = I$ where I is a 2×2 identity matrix.11. Given that matrix $A = \begin{pmatrix} 1 & 3 \\ 2 & 2 \end{pmatrix}$, find the values of the scalar λ for which $A - \lambda I$ where I is a 2×2 identity matrix. [Ans: $\lambda = 1$ or 4]

CHAPTER 7: INTEGRATION

Integration is the process of obtaining an original function from a given gradient function; hence it is the reverse of differentiation

$$\text{If } \frac{dy}{dx} = x^n, \text{ then } y = \frac{x^{n+1}}{n+1} \text{ when } n \neq -1$$

$$\Rightarrow \int ax^n dx = \frac{x^{n+1}}{n+1} + C \text{ where } C \text{ is the arbitrary constant}$$

The general rule when integrating a power of x is that we add one onto the exponent/power and then divide by the new exponent/power. It is clear (hopefully) that we will need to avoid $n = -1$ in this formula. If we allow $n = -1$ in this formula we will end up with division by zero, which is undefined.

Indefinite integrals

We call $\int f(x) dx$ an indefinite integral because it does not give a definite answer and we add an arbitrary constant after integrating.

We know that $y = x^3, y = x^3 + 5, y = x^3 - 6$, all satisfy $\frac{dy}{dx} = 3x^2$, for this reason we write $y = 3x^2 + C$ after integrating because we do not know whether the original function or not.

Note: we always integrate with respect to a certain variable i.e. $\int f(x) dx$ means integrating the function with respect to x and $\int f(t) dt$ means integrating the function with respect to t .

Example 1

Integrate the following with respect to x

(a) 5

Solution

$$\int 5 dx = \int 5x^0 dx = \frac{5x^1}{1} + c = 5x + c$$

$$\text{Hence } \int k dx = kx + c, \quad c \text{ and } k \text{ are constants}$$

(b) x^3

Solution

$$\int x^3 dx = \frac{x^{3+1}}{3+1} + c = \frac{x^4}{4} + c$$

(c) $x^{\frac{3}{2}}$

Solution

$$\begin{aligned} \int x^{\frac{3}{2}} dx &= \frac{x^{\frac{3}{2}+1}}{\frac{3}{2}+1} + c = \frac{x^{\frac{5}{2}}}{\frac{5}{2}} + c \\ &= \frac{2x^{\frac{5}{2}}}{5} + c \end{aligned}$$

(d) $4\sqrt{x}$

Solution

$$\int 4\sqrt{x} dx = \int 4x^{\frac{1}{2}} dx = 4 \frac{x^{\frac{1}{2}+1}}{\frac{1}{2}+1} + c$$

$$= \frac{4x^{\frac{3}{2}}}{\frac{3}{2}} + c = \frac{8x^{\frac{3}{2}}}{3} + c$$

(e) $7x^5$

Solution

$$\int 7x^5 dx = \frac{7x^6}{6} + c$$

(f) $\frac{1}{\sqrt{x}}$

Solution

$$\int \frac{1}{\sqrt{x}} dx = \int \frac{1}{x^{\frac{1}{2}}} dx = \int x^{-\frac{1}{2}} dx = \frac{x^{-\frac{1}{2}+1}}{-\frac{1}{2}+1} + c = \frac{x^{\frac{1}{2}}}{\frac{1}{2}} + c = 2x^{\frac{1}{2}} + c = 2\sqrt{x} + c$$

Integrating a sum or difference

When integrating a sum or difference we integrate separately i.e.

Example 2

Integrate $3x^3 - 4x^2 + 5x - 1$ with respect to x

Solution

$$\begin{aligned} \int (3x^3 - 4x^2 + 5x - 1) dx &= \int 3x^3 dx - \int 4x^2 dx + \int 5x dx - \int 1 dx \\ &= \frac{3x^4}{4} - \frac{4x^3}{3} + \frac{5x^2}{2} - x + c \end{aligned}$$

Example 3

Integrate $5t^3 - 10t^{-6} + 4$ with respect to t

Solution

$$\begin{aligned} \int 5t^3 - 10t^{-6} + 4 dt &= 5\left(\frac{1}{4}\right)t^4 - 10\left(\frac{1}{-5}\right)t^{-5} + 4t + c \\ &= \frac{5}{4}t^4 + 2t^{-5} + 4t + c \end{aligned}$$

Definite integrals

A definite integral is one that gives a definite answer i.e. $\int_a^b f(x) dx$ is a definite integral where a is the lower limit and b is the upper limit.

Suppose $\int f(x) dx = F(x) + c$

$$\begin{aligned} \int_{x=a}^{x=b} f(x) dx &= (F(b) + c) - (F(a) + c) \\ &= F(b) - F(a) \end{aligned}$$

We usually write this as $\int_{x=a}^{x=b} f(x) dx = [F(x)]_a^b$ where $f(x) = \frac{d}{dx} F(x)$

Note: The constants of integration cancel out in case of a definite integral thus there is no need to add an arbitrary constant to the final answer.

Examples

1. Evaluate the following definite integrals

(a) $\int_1^2 y^2 + y^{-2} dy$

Solution

$$\begin{aligned}\int_1^2 y^2 + y^{-2} dy &= \left(\frac{1}{3}y^3 - \frac{1}{y} \right) \Big|_1^2 \\ &= \frac{1}{3}(2)^3 - \frac{1}{2} - \left(\frac{1}{3}(1)^3 - \frac{1}{1} \right) \\ &= \frac{8}{3} - \frac{1}{2} - \frac{1}{3} + 1 \\ &= \frac{17}{6}\end{aligned}$$

(b) $\int_{-3}^1 6x^2 - 5x + 2 dx$

Solution

$$\begin{aligned}\int_{-3}^1 6x^2 - 5x + 2 dx &= \left(2x^3 - \frac{5}{2}x^2 + 2x \right) \Big|_{-3}^1 \\ &= \left(2 - \frac{5}{2} + 2 \right) - \left(-54 - \frac{45}{2} - 6 \right) \\ &= 84\end{aligned}$$

(c) $\int_4^0 \sqrt{t}(t-2) dt$

Solution

Note that we can't integrate products as a product of integrals and so we first need to multiply the integrand out before integrating.

$$\begin{aligned}\int_4^0 \sqrt{t}(t-2) dt &= \int_4^0 t^{\frac{3}{2}} - 2t^{\frac{1}{2}} dt \\ &= \left(\frac{2}{5}t^{\frac{5}{2}} - \frac{4}{3}t^{\frac{3}{2}} \right) \Big|_4^0 \\ &= 0 - \left(\frac{2}{5}(4)^{\frac{5}{2}} - \frac{4}{3}(4)^{\frac{3}{2}} \right) \\ &= -\frac{32}{15}\end{aligned}$$

In the evaluation process recall that,

$$\begin{aligned}(4)^{\frac{5}{2}} &= \left((4)^{\frac{1}{2}} \right)^5 = (2)^5 = 32 \\ (4)^{\frac{3}{2}} &= \left((4)^{\frac{1}{2}} \right)^3 = (2)^3 = 8\end{aligned}$$

(d) $\int_0^2 x^2 + 1 dx$

Solution

$$\begin{aligned}\int_0^2 x^2 + 1 dx &= \left(\frac{1}{3} x^3 + x \right) \Big|_0^2 \\ &= \frac{1}{3} (2)^3 + 2 - \left(\frac{1}{3} (0)^3 + 0 \right) \\ &= \frac{14}{3}\end{aligned}$$

(e) $\int_1^4 x^{1/2} dx$

Solution

$$\begin{aligned}\int_1^4 x^{1/2} dx &= \left[\frac{2}{3} x^{3/2} \right]_1^4 \\ &= \frac{2}{3} (4)^{3/2} - \frac{2}{3} (1)^{3/2} \\ &= \frac{16}{3} - \frac{2}{3} \\ &= \frac{14}{3}\end{aligned}$$

(f) $\int_1^3 (x^2 - 4x + 1) dx$

Solution

$$\begin{aligned}\int_1^3 (x^2 - 4x + 1) dx &= \left[\frac{1}{3} x^3 - 2x^2 + x \right]_1^3 \\ &= \left[\frac{1}{3} (3)^3 - 2(3)^2 + 3 \right] - \left[\frac{1}{3} (1)^3 - 2(1)^2 + 1 \right] \\ &= (-6) - \left(-\frac{2}{3} \right) \\ &= -\frac{16}{3}\end{aligned}$$

Area under the curve

The area between the graph of $y = f(x)$ and the x -axis is given by the definite integral below. This formula gives a positive result for a graph above the x -axis, and a negative result for a graph below the x -axis.

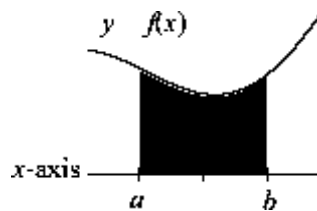

$$\text{Area} = \int_a^b f(x) dx$$

Example 1

Find the area between $y = 7 - x^2$ and the x-axis between the values $x = -1$ and $x = 2$.

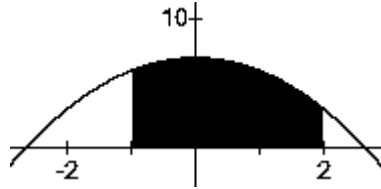

$$\begin{aligned} \text{Area} &= \int_{-1}^2 (7 - x^2) dx \\ &= \left(7x - \frac{1}{3}x^3 \right) \Big|_{-1}^2 \\ &= \left[7 \cdot 2 - \frac{1}{3}(8) \right] - \left[7(-1) - \frac{1}{3}(-1) \right] \\ &= 18 \end{aligned}$$

Example 2

Find the area enclosed by the curve $y = 4x - x^2$ and the x-axis

Solution

We can first sketch the curve as follows;

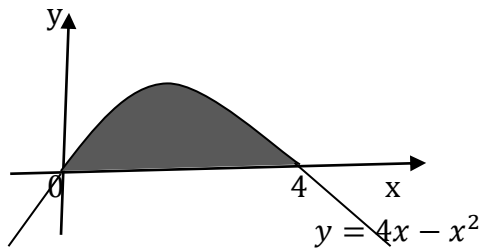

$$\begin{aligned} A &= \int y dx \\ A &= \int_0^4 (4x - x^2) dx \\ &= \left[2x^2 - \frac{x^3}{3} \right]_0^4 \\ &= \left(32 - \frac{64}{3} \right) - (0) = \frac{32}{3} \text{ sq. units} \end{aligned}$$

Example 3

Find the area enclosed by the curve $y = x^2 - 3x$ and the x-axis

Solution

First make a sketch of the curve $y = x^2 - 3x$

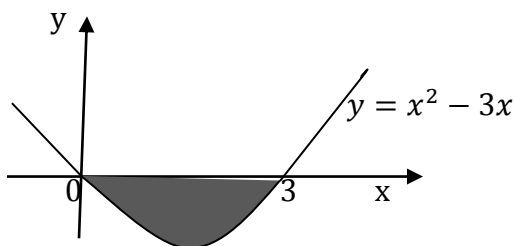

$$\begin{aligned}
 A &= \int y \, dx \\
 A &= \int_0^3 (x^2 - 3x) \, dx \\
 &= \left[\frac{x^3}{3} - \frac{3x^2}{2} \right]_0^3 \\
 &= \left(9 - \frac{27}{2} \right) - (0) \\
 &= -\frac{9}{2} \text{ sq. units}
 \end{aligned}$$

The area has a negative value because it lies below the x-axis but we shall always take the positive value $\therefore A = \frac{9}{2}$ sq. units

Displacement, velocity and acceleration

We earlier saw that displacement, velocity and acceleration are linked up with a process of differentiation.

Similarly, acceleration (a), velocity (v) and displacement in the reverse order are linked up together by a process of integration

From $= \frac{dv}{dt}$, it follows that $v = \int a \, dt$

And similarly from $= \frac{ds}{dt}$, it follows that $s = \int v \, dt$

Examples

1. If $v = 3t^2 - 8t$ and $s = 3$ when $t = 0$, find the expression for s in terms of t

Solution

$$\begin{aligned}
 s &= \int v \, dt \\
 s &= \int (3t^2 - 8t) \, dt \\
 s &= t^3 - 4t^2 + c
 \end{aligned}$$

But $s = 3$, when $t = 0 \Rightarrow c = 3$

$$\text{Thus } s = t^3 - 4t^2 + 3$$

2. If $v = t^2 - 4t + 3$ and $s = 4$ when $t = 3$, find the displacement when $s = 1$

Solution

$$\begin{aligned}
 s &= \int v \, dt \\
 s &= \int (t^2 - 4t + 3) \, dt \\
 s &= \frac{t^3}{3} - 2t^2 + 3t + c
 \end{aligned}$$

But $s = 4$ when $t = 3$

Substituting; $4 = 9 - 18 + 9 + c$

$$c = 4$$

$$s = \frac{t^3}{3} - 2t^2 + 3t + 4$$

Displacement when $t = 1$, $s = \frac{(1)^3}{3} - 2(1)^2 + 3(1) + 4$

$$s = \frac{16}{3} \text{ m}$$

3. If $a = 1 - t$ and when $t = 2$, $v = 1$ and $= \frac{13}{3}$, find the expressions for v and s in terms of t.

Solution

$$v = \int a \, dt$$

$$v = \int (1 - t) \, dt$$

$$v = t - \frac{t^2}{2} + c$$

But when $t = 2$, $v = 1$

$$1 = 2 - \frac{2^2}{2} + c$$

$$c = 1$$

Therefore $v = t - \frac{t^2}{2} + 1$

From $s = \int v \, dt$

$$s = \int \left(t - \frac{t^2}{2} + 1 \right) dt$$

$$s = \frac{t^2}{2} - \frac{t^3}{3} + 2t + c$$

But when $t = 1$, $s = \frac{13}{3}$

$$\text{Substituting; } \frac{13}{3} = \frac{1}{2} - \frac{1}{6} + 2 + c$$

$$\frac{13}{3} = \frac{1}{3} + 2 + c$$

$$c = 2$$

$$\text{Thus } s = \frac{t^2}{2} - \frac{t^3}{3} + 2t + 2$$

4. A body moves in a straight line. At a time t seconds, its acceleration is given by $a = 6t + 1$. When $t = 0$, the velocity of the body is 2 m/s and its displacement is 1 m. Find the expressions for v and s in terms of t .

Solution

$$a = \frac{dv}{dt} = 6t + 1$$

$$v = \int a \, dt = \int (6t + 1) \, dt$$

$$v = 3t^2 + t + c$$

But when $t = 0$, $v = 2$, thus $2 = 0 + c \Rightarrow c = 2$

Substituting for c ; $v = 3t^2 + t + 2$

Now using $v = \frac{ds}{dt} = 3t^2 + t + 2$

$$s = \int v \, dt = \int (3t^2 + t + 2) \, dt$$

$$s = t^3 + \frac{t^2}{2} + 2t + c$$

But when $t = 0$, $s = 1$

$$\Rightarrow 1 = 0 + c \text{ thus } c = 1$$

Substituting for c ; $s = t^3 + \frac{t^2}{2} + 2t + 1$

Trial questions

1. Integrate the following with respect to x

(i) x^5 (ii) $\frac{1}{x^5}$ (iii) $\sqrt[4]{x}$ (iv) x^{-3} (v) $\frac{1}{x^{5/2}}$ (vi) $x^{-1/2}$ (vii) x (viii) $\frac{1}{\sqrt[3]{x}}$

[Ans: (i) $\frac{1}{6}x^6 + c$ (ii) $-\frac{1}{4}x^{-4} + c$ (iii) $\frac{4}{5}x^{5/4} + c$ (iv) $-\frac{1}{2}x^{-2} + c$ (v) $-\frac{2}{3}x^{-3/2} + c$

(vi) $2x^{1/2} + c$ (vii) $\frac{1}{2}x^2 + c$ (viii) $\frac{3}{2}x^{2/3} + c$]

2. Evaluate each of the following definite integrals

(i) $\int_0^2 x^3 dx$ (ii) $\int_1^2 x^5 dx$ (iii) $\int_2^4 (x^2 + 4) dx$ (iv) $\int_0^3 (x^2 + 2x - 1) dx$

(v) $\int_0^2 (x^3 - 3x) dx$ (vi) $\int_1^2 (x^3 - 3x^2 + 2x) dx$ (vii) $\int_{-1}^1 (2x - 3) dx$ (viii) $\int_{1/4}^{1/2} \frac{1}{x^3} dx$

[Ans: (i) 4 (ii) $\frac{63}{6}$ (iii) $26\frac{2}{3}$ (iv) 15 (v) -2 (vi) $-\frac{1}{4}$ (vii) -6 (viii) 6]

3. Find the area enclosed by the curve $y = x^2 - 1$ and the x -axis. [Ans: $\frac{4}{3}$ sq. units]

4. Find the area bounded by the curve $y = x^2 + 3$ and the lines $x = 1$ and $x = 2$

[Ans: 4 sq. units]

5. Find the area enclosed by the curve $y = x^2 - 6x$ and the x -axis [Ans: 36 sq. units]

6. Find the area enclosed by the curve $y = 4 + 3x - x^2$ and x -axis [Ans: $20\frac{5}{6}$ sq. units]

7. Find the area enclosed by the curve $y = x^2 - 4x - 5$ and the x -axis. [Ans: 36 sq. units]

8. If $a = 6t - 12$, and when $t = 0$, $v = 9$ and $s = 6$, find the expressions for velocity and displacement [Ans: $v = 3t^2 - 12t + 9$, $s = t^3 - 6t^2 + 9t + 6$]

CHAPTER 8: VECTORS

A vector quantity is one that has magnitude and it is related to a definite or particular direction in space. A direct line segment, whose direction is that of the vector and whose length represents the magnitude of the vector, may represent any vector. A vector from a point A to a point B is denoted by \overrightarrow{AB} .

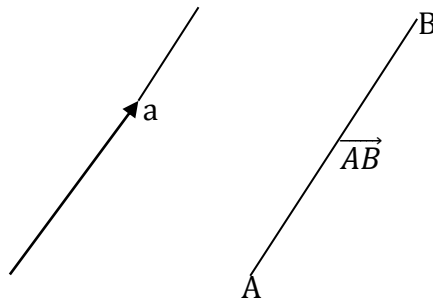

Vectors may be in 2-dimensions or 3-dimensions. If coordinates are involved, we use x, y in 2-dimensions and x, y, z in 3-dimensions. Vectors can be added together, subtracted and multiplied by scalars.

Equal vectors

For any two vectors to be equal, they must have the same magnitude and direction

Parallel vectors

Two vectors a and b are parallel if one is a scalar multiple of the other i.e.

$$a = \lambda b$$

Position vectors

A position vector whose distance and direction from the origin is specific. Consider a vector $ai + bj$

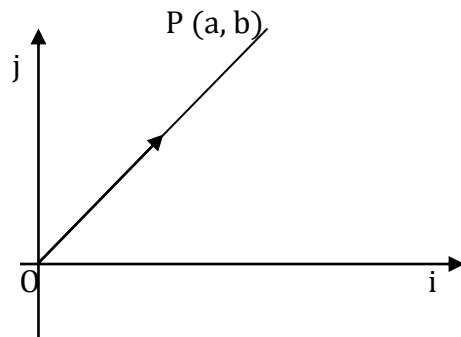

The position vector \overrightarrow{OP} is given by $\overrightarrow{OP} = ai + bj$

Addition and subtraction of vectors**Example**

If $a = 3i + 4j$ and $b = 2i + 8j$. Find (a) $a+b$ (b) $a-2b$

Solution

$$(a) a+b = 3i + 4j + 2i + 8j = 5i + 12j$$

$$\begin{aligned} (b) a-2b &= 3i + 4j - 2(2i + 8j) \\ &= 3i + 4j - 4i - 16j \\ &= -i - 12j \end{aligned}$$

Modulus of a vector

The modulus of a vector \mathbf{a} is the magnitude of \mathbf{a} i.e. the length of the line representing \mathbf{a} . The modulus of a vector \mathbf{a} is denoted by $|\mathbf{a}|$

$$|ai + bj| = \sqrt{a^2 + b^2}$$

Note: the vector $ai + bj$ can be denoted by $\begin{pmatrix} a \\ b \end{pmatrix}$ which is a column vector.

Example

Given that $a = 3i + 4j$ and $b = 2i + 8j$. Find (a) $|a|$ (b) $|b|$ (c) $|a + b|$

Solution

$$(a) |a| = \sqrt{3^2 + 4^2} = \sqrt{25} = 5$$

$$(b) |b| = \sqrt{2^2 + 8^2} = \sqrt{68} = 2\sqrt{17}$$

$$(c) a + b = 3i + 4j + 2i + 8j$$

$$|a + b| = \sqrt{5^2 + 12^2} = \sqrt{169} = 13$$

Unit vectors

A unit vector is a vector whose magnitude or length is one. It is usually written as \tilde{a} . The unit vector of \mathbf{a} is given by $\tilde{a} = \frac{\mathbf{a}}{|\mathbf{a}|}$

Example1

Find the unit vector of $2i - j$

Solution

$$|2i - j| = \sqrt{2^2 + (-1)^2} = \sqrt{5} \text{ Units}$$

The unit vector will be $\frac{1}{\sqrt{5}}(2i - j)$

Example2

Find the unit vector of \mathbf{a} if $a = 3i + 2j$

$$|a| = \sqrt{3^2 + 2^2} = \sqrt{13}$$

$$\tilde{a} = \frac{\mathbf{a}}{|\mathbf{a}|}$$

$$\tilde{a} = \frac{1}{\sqrt{13}}(3i + 2j)$$

\therefore The unit vector is $\frac{1}{\sqrt{13}}(3i + 2j)$

Further examples

1. In a parallelogram OABC, $\vec{OA} = \mathbf{a}$ and $\vec{OC} = \mathbf{c}$. The point D lies on AB such that AD: DB = 1:2. Express the following vectors in terms of \mathbf{a} and \mathbf{c} .

(a) \vec{CB} (b) \vec{BC} (c) \vec{AB} (d) \vec{AD} (e) \vec{OD} (f) \vec{DC}

Solution

Let us draw the parallelogram

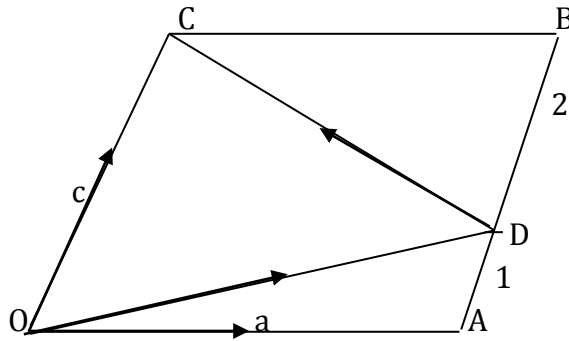

(a) \vec{CB} is the same length as \vec{OA} and it is in the same direction $\Rightarrow \vec{CB} = \vec{OA}$
 $\therefore \vec{CB} = a$

(b) \vec{BC} is the same length as \vec{CB} but it is in the same direction $\Rightarrow \vec{BC} = -\vec{CB}$
 $\therefore \vec{BC} = -a$

(c) \vec{AB} is the same length as \vec{OC} and is in the same direction $\Rightarrow \vec{AB} = \vec{OC}$
 $\therefore \vec{OC} = c$

(d) $AD:DB = 1:2$
 $\vec{AD} = \frac{1}{3}\vec{AB}$
 $\vec{AD} = \frac{1}{3}c$

(e) $\vec{OD} = \vec{OA} + \vec{AD}$
 $= a + \frac{1}{3}c$
 $= \frac{1}{3}(3a + c)$

(f) $\vec{DC} = \vec{DB} + \vec{BC}$
 $= \frac{2}{3}c + (-a)$
 $= \frac{2}{3}(2c - 3a)$

2. The diagram below shows a parallelogram OABC with $\vec{OA} = a$ and $\vec{OC} = c$. D is a point on AB such that $AD:DB = 2:1$. OD produced meets CB produced at E. $\vec{DE} = h\vec{OD}$ and $\vec{BE} = k\vec{CB}$. Find

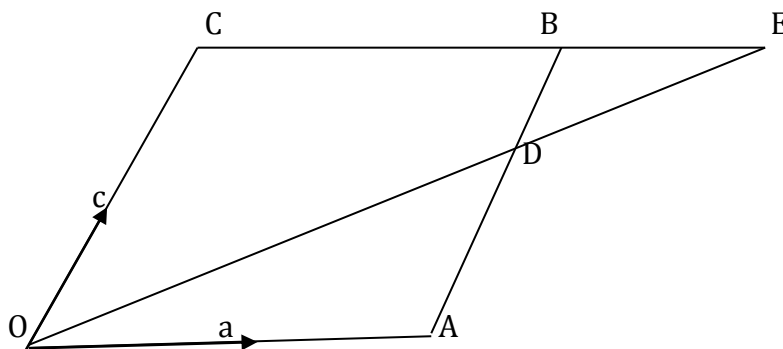

(a) \vec{BE} in terms of a and k

(b) \vec{DE} in terms of h, a and c

Solution

(a) $\overrightarrow{BE} = k\overrightarrow{CB}$

But $\overrightarrow{CB} = \overrightarrow{OA} = a$

$\therefore \overrightarrow{BE} = ka$

(b) $\overrightarrow{DE} = h\overrightarrow{OD}$

But $\overrightarrow{OD} = \overrightarrow{OA} + \overrightarrow{AD} = a + \frac{2}{3}\overrightarrow{AB}$

$= a + \frac{2}{3}c = \frac{1}{3}(3a + 2c)$

$\therefore \overrightarrow{DE} = h \times \frac{1}{3}(3a + 2c) = \frac{h}{3}(3a + 2c)$

3. If O, A, B, C are four points such that $\overrightarrow{OA} = 10a$, $\overrightarrow{OB} = 5b$, $\overrightarrow{OC} = 4a + 3b$. Show that A, B and C are collinear

Solution

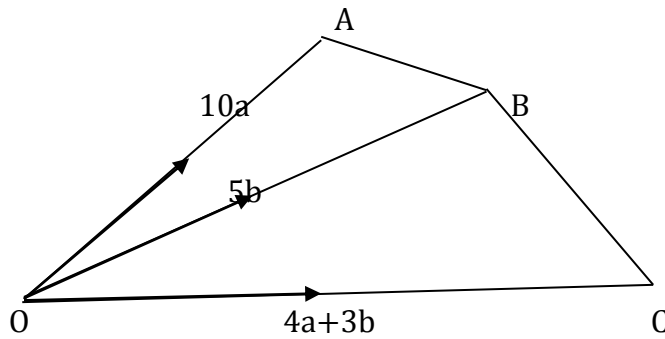

$\overrightarrow{AB} = \overrightarrow{AO} + \overrightarrow{OB}$

$= -10a + 5b$

$= 5b - 10a$

$= 5(b - 2a)$

$\overrightarrow{BC} = \overrightarrow{BO} + \overrightarrow{OC}$

$= -5b + (4a + 3b)$

$= 4a - 2b$

$= -2(b - 2a)$

$\therefore \overrightarrow{BC} = -\frac{2}{5}\overrightarrow{AB}$

\overrightarrow{AB} and \overrightarrow{BC} are in opposite direction and since B is a common point, A, B and C are collinear

4. OABC is a parallelogram with $OA=a$ and $OC=c$, D is a midpoint of \overrightarrow{BC} and \overrightarrow{OD} meets \overrightarrow{AC} at E

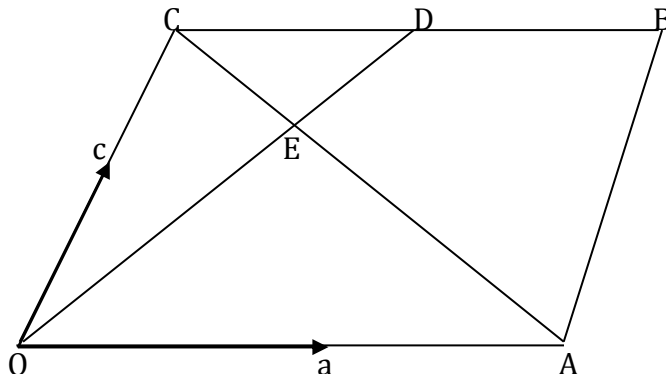

Given that $OE=hOD$ and $AE=kAC$

Find in terms of vectors a and c, the vectors OE, AE and CE

Solution

$$\text{From } OE = hOD$$

$$OD = OC + CD$$

$$CD = \frac{1}{2}CB = \frac{1}{2}OA = \frac{1}{2}a$$

$$OD = c + \frac{1}{2}a = \frac{1}{2}(2c + a)$$

$$OE = \frac{h}{2}(2c + a)$$

$$AE = AO + OE$$

$$= -a + \frac{h}{2}(2c + a)$$

$$= \frac{2hc + ha - 2a}{2} = \frac{1}{2}(2hc + (h - 2)a)$$

Alternatively:

$$\text{From } AE = kAC$$

$$AC = AO + OC$$

$$AC = OC - OA = c - a$$

$$AE = k(c - a)$$

$$CE = CO + OE$$

$$= OE - OC$$

$$= \frac{h}{2}(2c + a) - c$$

$$= \frac{2hc + ha - 2c}{2} = \frac{1}{2}(2c(h - 1) + ha)$$

5. M is the mid-point of \overline{PQ} in the triangle OPQ. If $OP = p$ and $OQ = q$, find in terms of the vectors p and q , the vectors PQ , PM and OM . N is a point on \overline{OM} such that $ON : NM = 2 : 1$. Express ON and PN in terms of p and q . Given that S is a mid point of \overline{OQ} , use vector methods to show that N lies on \overline{PS} and hence determine the ratio $\overline{PN} : \overline{SN}$

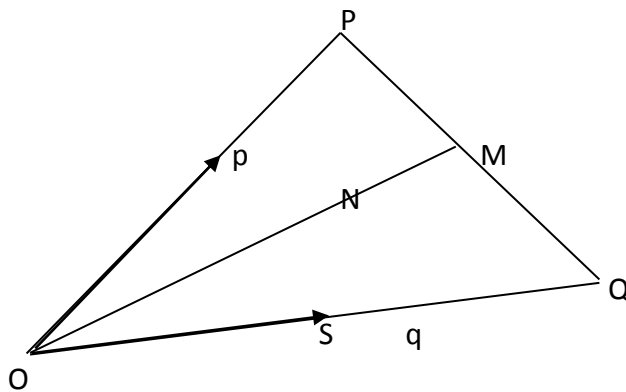
Solution

$$PQ = PO + OQ = -OP + OQ$$

$$PQ = OQ - OP$$

$$PQ = q - p$$

$$PM = \frac{1}{2}PQ, \text{ since M is the mid-point of } \overline{PQ}$$

$$PM = \frac{1}{2}(q - p)$$

$$OM = OP + PM$$

$$= p + \frac{1}{2}q - \frac{1}{2}p$$

$$= \frac{1}{2}(p + q)$$

$$ON : NM = 2 : 1 \quad (\text{total ratio} = 2 + 1 = 3)$$

$$\Rightarrow ON = \frac{2}{3}OM = \frac{2}{3} \times \frac{1}{2}(p + q)$$

$$\therefore ON = \frac{1}{3}(p + q)$$

$$PN = PO + ON \quad (\text{see diagram})$$

$$= -OP + ON = ON - OP = \frac{1}{3}(p + q) - p = \frac{1}{3}q - \frac{2}{3}p$$

$$\therefore PN = \frac{1}{3}(q - 2p)$$

$$\text{Now } NS = NO + OS = OS - ON$$

$$\text{But } OS = \frac{1}{2}OQ \quad \text{since } S \text{ is the mid-point of } OQ$$

$$\Rightarrow OS = \frac{1}{2}q$$

$$\text{Also } ON = \frac{1}{3}(p + q) \text{ from above}$$

$$\Rightarrow NS = \frac{1}{2}q - \frac{1}{3}(p + q) = \frac{1}{2}q - \frac{1}{3}p - \frac{1}{3}q = \frac{3q - 2p - 2q}{6} = \frac{q - 2p}{6}$$

$$NS = \frac{1}{6}(q - 2p)$$

$$\text{But } PN = \frac{1}{3}(q - 2p) \text{ so } \frac{PN}{NS} = \frac{\frac{1}{3}(q - 2p)}{\frac{1}{6}(q - 2p)} = \frac{1}{3} \times \frac{6}{1} = 2$$

$$\frac{PN}{NS} = 2 \Rightarrow PN = 2NS$$

Since PN is a scalar multiple of NS, then PN is parallel to NS.

But since both vectors contain a common point N, N and S are collinear (lie on a straight line) and so N lies on PS as required.

$$\text{Now } \frac{PN}{NS} = \frac{2}{1} \text{ so } PN : NS = 2 : 1$$

$$\text{Hence } \overline{PN} : \overline{SN} = 2 : 1$$

The scalar product

The scalar dot product of two vectors is defined as the product of the magnitude of the two vectors and the cosine of the angle between the two vectors

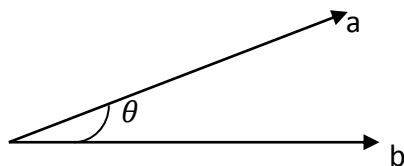

$$a \cdot b = |a||b| \cos \theta$$

The scalar dot product can therefore be used to obtain the angle between vectors.

Properties of the scalar product

1. From definition $a \cdot b = |a||b| \cos \theta$, it follows that two perpendicular vectors have a scalar product of zero

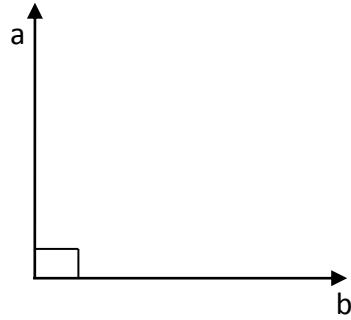

$$a \cdot b = |a||b| \cos 90$$

$$\Rightarrow a \cdot b = 0$$

2. $a \cdot b = b \cdot a$
3. $a \cdot (b + c) = a \cdot b + a \cdot c$
4. $\lambda(a \cdot b) = a \cdot (\lambda b) = (\lambda a) \cdot b = \lambda|a||b| \cos \theta$

Consider the vectors $a = x_1i + y_1j$ and $b = x_2i + y_2j$

$$\text{Now } a \cdot b = (x_1i + y_1j) \cdot (x_2i + y_2j)$$

$$= x_1x_2i \cdot i + x_1y_2i \cdot j + y_1x_2j \cdot i + y_1y_2j \cdot j$$

$$\text{But } i \cdot i = j \cdot j = 1 \text{ and } i \cdot j = j \cdot i = 0$$

$$\therefore a \cdot b = x_1x_2 + y_1y_2 = |a||b| \cos \theta \text{ Where } \theta \text{ is the acute angle between } a \text{ and } b.$$

Example 1

Find the angle between the vectors a and b given that $a = 3i + 4j$ and $b = 5i - 12j$

Solution

Let θ be the required angle

$$a \cdot b = |a||b| \cos \theta$$

$$|a| = \sqrt{3^2 + 4^2} = 5 \text{ and } |b| = \sqrt{5^2 + (-12)^2} = 13$$

$$a \cdot b = (3 \times 5) + (4 \times -12) = 15 - 48 = -33$$

$$-33 = 5 \times 13 \cos \theta$$

$$\frac{-33}{65} = \cos \theta$$

$$\cos \theta = -0.50769$$

$$\theta = \cos^{-1}(-0.50769)$$

$$\theta = 120.51^\circ$$

$$\therefore \text{The angle between the vectors is } 120.51^\circ$$

Example 2

The points A, B, C and D have position vectors $-2i + 3j$, $3i + 8j$, $7i + 6j$ and $7i - 4j$ respectively. Show that AC is perpendicular to BD.

Solution

$$\vec{AC} = \vec{OC} - \vec{OA}$$

$$= (7i + 6j) - (-2i + 3j)$$

$$= 9i + 3j$$

$$\vec{BD} = \vec{OD} - \vec{OB}$$

$$= (7i - 4j) - (3i + 8j)$$

$$= 4i - 12j$$

$$AC \cdot BD = (9i + 3j) \cdot (4i - 12j)$$

$$= (9 \times 4) - (3 \times 12) = 36 - 36 = 0$$

\therefore Since $AC \cdot BD = 0$, AC is perpendicular to BD

Example 3

The position vectors $OP = \begin{pmatrix} 2 \\ 3 \end{pmatrix}$ and $OQ = \begin{pmatrix} 4 \\ -1 \end{pmatrix}$ are joined to form triangle OPQ. Determine;

- (i) The lengths of the sides of triangle OPQ
- (ii) The angle between OP and OQ
- (iii) The area of triangle OPQ

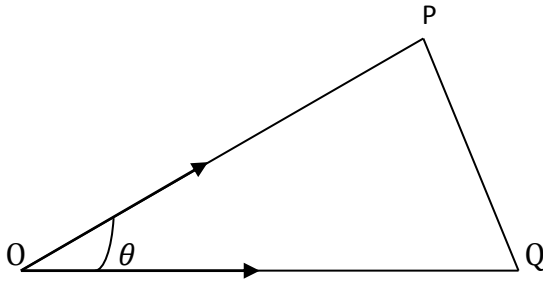
Solution

$$(i) \overline{OP} = |OP| \sqrt{2^2 + 3^2} = \sqrt{13} \text{ units}$$

$$\overline{OQ} = |OQ| \sqrt{4^2 + (-1)^2} = \sqrt{17} \text{ units}$$

$$\overline{PQ} = \overline{OQ} - \overline{OP} = \begin{pmatrix} 4 \\ -1 \end{pmatrix} - \begin{pmatrix} 2 \\ 3 \end{pmatrix} = \begin{pmatrix} 2 \\ -4 \end{pmatrix}$$

$$\overline{PQ} = |PQ| \sqrt{2^2 + (-4)^2} = \sqrt{20} \text{ units}$$

$$(ii) OP \cdot OQ = (2 \times 4) + (3 \times -1) = 8 - 3 = 5$$

$$\text{Using } OP \cdot OQ = |OP| |OQ| \cos \theta$$

$$5 = \sqrt{13} \times \sqrt{17} \cos \theta$$

$$\cos \theta = \frac{5}{\sqrt{221}} = 0.336$$

$$\theta = 70.37^\circ$$

$$(iii) \text{Area} = \frac{1}{2} |OP| |OQ| \sin \theta$$

$$= \frac{1}{2} \times \sqrt{13} \times \sqrt{17} \sin 70.37$$

$$= 7 \text{ sq. units}$$

Trial questions

- If the point P has position vector $7i - 3j$ and point Q has position vector $5i + 5j$. Find (a) \overrightarrow{PQ} (b) \overrightarrow{QP} [Ans:(a) $-2i + 8j$ (b) $2i - 8j$]
- The point P has position vector $3i - 2j$ and Q is a point such that $\overrightarrow{QP} = 2i - 3j$. Find the position vector of Q. [Ans: $i + j$]
- Given that $a = 3i - j$ and $b = 2i + j$, find:
(a) $|a|$ (b) $|b|$ (c) $a + b$ (d) $|a + b|$ [Ans: (a) $\sqrt{10}$ (b) $\sqrt{5}$ (c) $5i$ (d) 5]
- Given that $a = \begin{pmatrix} 2 \\ 3 \end{pmatrix}$ and $b = \begin{pmatrix} 1 \\ -3 \end{pmatrix}$, find:
(a) $a + 2b$ (b) $|a + 2b|$ (c) $2a + 3b$ (d) $|2a + 3b|$
[Ans: (a) $\begin{pmatrix} 4 \\ -3 \end{pmatrix}$ (b) 5 (c) $\begin{pmatrix} 7 \\ -3 \end{pmatrix}$ (d) $\sqrt{58}$]
- The three points A, B and C have position vectors a , b and c respectively. If $c = 3b - 2a$. Show that A, B and C are collinear.
- The three points A, B and C have position vectors $i - j$, $5i - 3j$ and $11i - 6j$ respectively. Show that A, B and C are collinear.
- Find the angle between each of the following vectors
(a) $a = 3i + 4j$ and $b = 5i + 12j$ [Ans: 14°]
(b) $c = 5i - j$ and $d = 2i + 3j$ [Ans: 68°]
- The points A, B, C and D have position vectors $5i + j$, $-3i + 2j$, $-3i - 3j$ and $i - 6j$ respectively. Show that AC is perpendicular to BD.
- The points E, F and G have position vectors $2i + 2j$, $i + 6j$ and $-7i + 4j$. Show that the triangle EFG is right angled at F.
- If $a = \begin{pmatrix} 3 \\ -4 \end{pmatrix}$ find (a) a unit vector parallel to a [Ans: $\begin{pmatrix} \frac{3}{5} \\ -\frac{4}{5} \end{pmatrix}$]
- The points A, B and C have position vectors $4i - j$, $i + 3j$ and $-5i + 2j$ respectively. Find (a) \overrightarrow{AB} (b) \overrightarrow{BC} (c) \overrightarrow{CA} (d) the angles of a triangle ABC
[Ans: (a) $-3i + 4j$ (b) $-6i - j$ (c) $9i - 3j$ (d) $35^\circ, 117^\circ, 28^\circ$]
- E is the centre of the rectangle ABCD and $\overrightarrow{AB} = a$, $\overrightarrow{BC} = b$, Express in terms of a and b , the vectors (i) \overrightarrow{AC} (ii) \overrightarrow{CD} (iii) \overrightarrow{BD} (iv) \overrightarrow{EB} (v) \overrightarrow{EA}
[Ans: (i) $a + b$ (ii) $-a$ (iii) $b - a$ (iv) $\frac{1}{2}(a - b)$ (v) $-\frac{1}{2}(a + b)$]
- The position vectors of three points A, B and C relative to an origin O are p , $3q - p$ and $9q - 5p$ respectively. Show that the points A, B and C lie on the same straight line, and state the ratio of AB:BC
Given that OBCD is a parallelogram and that E is the point such that $DB = \frac{1}{3}DE$, find the position vectors of D and E relative to O [Ans: $1 : 2, 6q - 4p, 5p - 3q$]
- The position vectors of the points A and B with respect to the origin O are $2i + 3j$, $-i + 5j$ respectively. Find the position vector C such that $\overrightarrow{AC} = 2\overrightarrow{AB}$. Calculate the angle between the vectors \overrightarrow{AB} and \overrightarrow{OB} . [Ans: $-4i + 7j, 45^\circ$]

15. The position vectors of points A, B and C relative to the origin O are $\begin{pmatrix} 1 \\ 3 \end{pmatrix}$, $\begin{pmatrix} 2 \\ 6 \end{pmatrix}$ and $\begin{pmatrix} 5 \\ 5 \end{pmatrix}$ respectively. Write down the vectors representing \overrightarrow{AB} , \overrightarrow{AC} and \overrightarrow{BC} . Use the vector methods to calculate (i) angle BAC (ii) angle ABC
State the special property of triangle ABC and deduce its area.

[Ans: $\begin{pmatrix} 1 \\ 3 \end{pmatrix}$, $\begin{pmatrix} 4 \\ 2 \end{pmatrix}$, $\begin{pmatrix} 3 \\ -1 \end{pmatrix}$, 45° , 90° , right angled isosceles, 5 sq. units]

CHAPTER 9: TRIGONOMETRY

Trigonometry is a branch of mathematics that studies the relationship between the three sides and the three angles of a right angled triangle in terms of ratios and representing them as trigonometric ratios; sine, cosine and tangent.

Trigonometric ratios for the general angle

The trigonometric ratios include the main three mentioned above and the others include secant, cosecant and cotangent abbreviated as sec, cosec and cot respectively.

If we consider a right angled triangle ABC

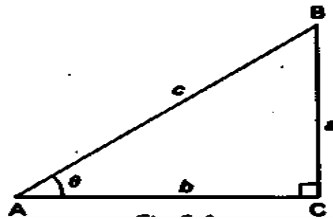

$$\text{Then } \sin \theta = \frac{a}{c}, \cos \theta = \frac{b}{c}$$

$$\text{Also } \tan \theta = \frac{a}{b} = \frac{\frac{a}{c}}{\frac{b}{c}} = \frac{\sin \theta}{\cos \theta}$$

It can also be observed that the remaining angle, $B = 90 - \theta$

$$\text{And that } \sin(90 - \theta) = \frac{b}{c} = \cos \theta \text{ and } \cos(90 - \theta) = \frac{a}{c} = \sin \theta$$

$$\text{Therefore } \sin \theta = \cos(90 - \theta) \text{ and } \cos \theta = \sin(90 - \theta)$$

$$\text{By Pythagoras theorem, } a^2 + b^2 = c^2$$

On dividing through by c^2 , we get

$$\frac{a^2}{c^2} + \frac{b^2}{c^2} = 1$$

$$\Rightarrow \sin^2 \theta + \cos^2 \theta = 1$$

Though we have derived these relationships using an acute angle, they are identities i.e. true for any angle and should be remembered.

The three remaining ratios are reciprocals of sine, cosine and tangent;

They are;

$$\text{secant} = \frac{1}{\cosine}; \text{ cosecant} = \frac{1}{sine}; \text{ cotangent} = \frac{1}{\text{tangent}} = \frac{\cosine}{sine}$$

Further trigonometrical identities

$$\text{Using } \sin^2 \theta + \cos^2 \theta = 1$$

Dividing both sides $\cos^2 \theta$

$$\frac{\sin^2 \theta}{\cos^2 \theta} + \frac{\cos^2 \theta}{\cos^2 \theta} = \frac{1}{\cos^2 \theta}$$

$$\text{But } \frac{\sin \theta}{\cos \theta} = \tan \theta \text{ and } \frac{1}{\cos \theta} = \sec \theta$$

$$\text{There fore } \tan^2 \theta + 1 = \sec^2 \theta$$

Now if we divide the original identity by $\sin^2 \theta$, we obtain

$$\frac{\sin^2 \theta}{\sin^2 \theta} + \frac{\cos^2 \theta}{\sin^2 \theta} = \frac{1}{\sin^2 \theta}$$

$$\text{But } \frac{\cos \theta}{\sin \theta} = \cot \theta \text{ and } \frac{1}{\sin \theta} = \text{cosec } \theta$$

Therefore $1 + \cot^2 \theta = \operatorname{cosec}^2 \theta$

These three identities will be found useful later when solving equations.

Trigonometric ratios for general angles

The relationship between the ratios of the general angles and the corresponding acute angles depends on which quadrant the basic angle lies in. The angles can lie in four quadrants following in the anti-clockwise direction. In the 1st quadrant, all are positive, in the 2nd quadrant only sine is positive, in the 3rd quadrant only tan is positive and in the 4th quadrant only cos is positive. Note that the positive angle are measured in the anticlockwise direction and the negative angles are measured in the clockwise direction.

The relationships can be summarized as shown below.

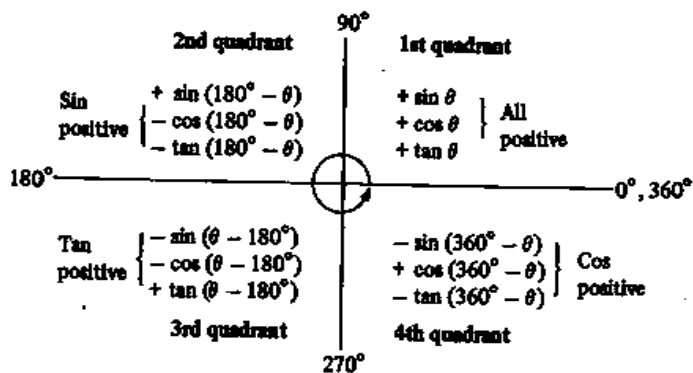

It can also be remembered by a student saying “All Scientists Take Chemistry” in the anticlockwise direction.

Trigonometric ratios for special angles

The trigonometrical ratios of the angles 0° , 30° , 45° , 60° and 90° are used often in mechanics and other branches of mathematics and so it is useful to have their values in surd form.

30° and 60°

Suppose ΔPQR is equilateral, with sides 2 units and that PM is the perpendicular bisector of QR

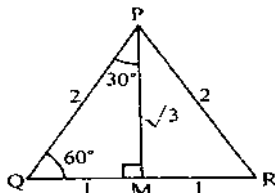

Using Pythagoras theorem $MP^2 + MQ^2 = PQ^2$

$$MP = \sqrt{2^2 - 1^2}$$

$$\text{So } MP = \sqrt{3}$$

Since ΔPQR is equilateral, $\angle PQM = 60^\circ$ and $\angle QPM = 30^\circ$

$$\text{From } \Delta PQM \quad \sin 30^\circ = \frac{1}{2}; \quad \cos 30^\circ = \frac{\sqrt{3}}{2}; \quad \tan 30^\circ = \frac{1}{\sqrt{3}} \text{ or } \frac{\sqrt{3}}{3}$$

$$\text{And } \sin 60^\circ = \frac{\sqrt{3}}{2}; \quad \cos 60^\circ = \frac{1}{2}; \quad \tan 60^\circ = \frac{\sqrt{3}}{1} = \sqrt{3}$$

45°

Consider a right-angled triangle which is isosceles and in which the equal sides are 1 unit in length. The equal angles will each be 45°

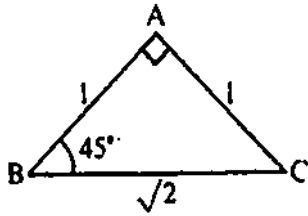

Using Pythagoras theorem $BC^2 = 1^2 + 1^2$ or $BC = \sqrt{2}$

Hence $\sin 45^\circ = \frac{1}{\sqrt{2}}$ or $\frac{\sqrt{2}}{2}$; $\cos 45^\circ = \frac{\sqrt{2}}{2}$; $\tan 45^\circ = \frac{1}{1} = 1$

0° and 90°

In the $\triangle ABC$, as the angle x decreases so does the length of side BC.

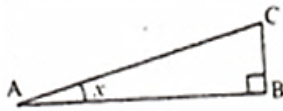

As x approaches 0° , BC approaches zero and AC approaches AB in length i.e. as $x \rightarrow 0$, then $b \rightarrow 0$ and $AC \rightarrow AB$

But $\sin x = \frac{BC}{AC}$ and as $x \rightarrow 0$, $BC \rightarrow 0$. Thus $\sin 0^\circ = \frac{0}{AC} = 0$

Also $\cos x = \frac{AB}{AC}$ and as $x \rightarrow 0$, $AC \rightarrow AB$. Thus $\cos 0^\circ = \frac{AB}{AB} = 1$

And $\tan x = \frac{BC}{AB}$ and as $x \rightarrow 0$, $BC \rightarrow 0$. Thus $\tan 0^\circ = \frac{0}{AB} = 0$

Similarly, as $x \rightarrow 0^\circ$, so $\angle ACB \rightarrow 90^\circ$. Thus considering the trigonometric ratios of $\triangle ACB$ as $x \rightarrow 0^\circ$

$$\sin 90^\circ = \frac{AB}{AB} = 1; \cos 90^\circ = \frac{0}{AC} = 0 \text{ and } \tan 90^\circ = \frac{\sin 90^\circ}{\cos 90^\circ} = \frac{1}{0} = \infty \text{ (infinity)}$$

These results are summarised in the table below and should be memorised for future use.

Angle	sin	cos	tan
0°	0	1	0
30°	$\frac{1}{2}$	$\frac{\sqrt{3}}{2}$	$\frac{1}{\sqrt{3}}$
45°	$\frac{1}{\sqrt{2}}$	$\frac{1}{\sqrt{2}}$	1
60°	$\frac{\sqrt{3}}{2}$	$\frac{1}{2}$	$\sqrt{3}$
90°	1	0	∞

Example 1

Show that $\cos^2 30^\circ + \cos 60^\circ \sin 30^\circ = 1$

Solution

The left hand side is $\cos^2 30^\circ + \cos 60^\circ \sin 30^\circ$

$$= \cos 30^\circ (\cos 30^\circ) + \cos 60^\circ \sin 30^\circ$$

$$= \frac{\sqrt{3}}{2} \times \frac{\sqrt{3}}{2} + \frac{1}{2} \times \frac{1}{2} = \frac{3}{4} + \frac{1}{4}$$

$$= 1 \text{ as required}$$

Obtuse angles

Trigonometric ratios of obtuse angles can not be defined by means of a right angled triangle.

The sine, cosine or tangent of an obtuse angle is the sine, cosine or tangent of a supplement angle, with the appropriate sign

If θ is an obtuse angle;

$$\sin \theta = + \sin(180^\circ - \theta)$$

$$\cos \theta = - \cos(180^\circ - \theta)$$

$$\tan \theta = - \tan(180^\circ - \theta)$$

Example 2

Write each of the following as trigonometric ratios of an acute angle

(a) $\sin 155^\circ$ (b) $\cos 140^\circ$ (c) $\tan 130^\circ$

solution

$$\begin{aligned} \text{(a) } \sin 155^\circ &= + \sin(180^\circ - 155^\circ) \\ &= + \sin 25^\circ \end{aligned}$$

$$\begin{aligned} \text{(b) } \cos 140^\circ &= - \cos(180^\circ - 140^\circ) \\ &= - \cos 40^\circ \end{aligned}$$

$$\begin{aligned} \text{(c) } \tan 130^\circ &= - \tan(180^\circ - 130^\circ) \\ &= - \tan 50^\circ \end{aligned}$$

Example 3

If $\sin 35^\circ = 0.5736$, find the values of (a) $\sin 145^\circ$ (b) $\cos 125^\circ$

Solution

$$\begin{aligned} \text{(a) } \sin 145^\circ &= + \sin(180^\circ - 145^\circ) \\ &= + \sin 35^\circ \\ &= +0.5736 \end{aligned}$$

$$\begin{aligned} \text{(b) } \cos 125^\circ &= - \cos(180^\circ - 125^\circ) \\ &= - \cos 55^\circ \\ &= - \cos(90^\circ - 35^\circ) \\ &= - \sin 35^\circ \\ &= -0.5736 \end{aligned}$$

Example 4

Given that $\sin \theta = \frac{7}{25}$ and that θ is an acute angle, find (a) $\cos \theta$, (b) $\tan \theta$

Solution

First sketch a right angled triangle containing an angle θ and with two sides of length 7 and 25 units such that $\sin \theta = \frac{7}{25}$

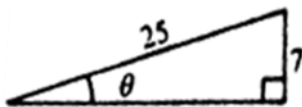

Using pythagoras theorem, the third side of the triangle $= \sqrt{25^2 - 7^2} = 24$

Since θ is acute, the trigonometrical ratios of θ will be positive, hence

(a) $\cos \theta = \frac{24}{25}$

(b) $\tan \theta = \frac{7}{24}$

Example 5

Given that $\sin \theta = \frac{24}{25}$ and that θ is an obtuse angle, find (a) $\cos \theta$, (b) $\tan \theta$

Solution

As θ is obtuse, sketch a right angled triangle containing an angle $(180^\circ - \theta)$ and with two sides of length 24 and 25 units.

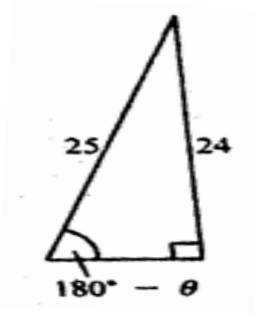

As $\sin \theta$ and $\sin(180^\circ - \theta)$ are numerically equal, $\sin(180^\circ - \theta) = \frac{24}{25}$

Using Pythagoras theorem, the third side of the triangle $= \sqrt{25^2 - 24^2} = 7$

$$\begin{aligned} \text{(a) } \cos \theta &= -\cos(180^\circ - \theta) \\ &= -\frac{24}{25} \end{aligned}$$

$$\begin{aligned} \text{(b) } \tan \theta &= -\tan(180^\circ - \theta) \\ &= -\frac{24}{7} \end{aligned}$$

Maximum and minimum values of sine and cosine

The trigonometrical ratios of all angles differ from the trigonometrical ratios of acute angles only in sign.

From the definition of sine and cosine

The maximum value of $\sin \theta$ is $+1$ (when $\theta = 90^\circ, 450^\circ, \dots$)

And the minimum value of $\sin \theta$ is -1 (when $\theta = 270^\circ, 630^\circ, \dots$)

The maximum value of $\cos \theta$ is $+1$ (when $\theta = 0^\circ, 360^\circ, \dots$)

And the minimum value of $\cos \theta$ is -1 (when $\theta = 180^\circ, 540^\circ, \dots$)

Example

Write down the maximum and minimum values of each of the following and state the smallest value of θ , from 0° to 360° , for which these values occur.

(a) $1 - 2 \cos \theta$ (b) $3 \sin \theta - 1$

Solution

(a) $\cos \theta$ varies from $+1$ to -1 , hence $2 \cos \theta$ varies from $+2$ to -2

Thus the maximum value of $1 - 2 \cos \theta$ is $1 - (-2) = 3$ and occurs when $\cos \theta = -1$ i.e. when $\theta = 180^\circ$

The minimum value of $1 - 2 \cos \theta$ is $1 - 2 = -1$ and occurs when $\cos \theta = 1$ i.e. when $\theta = 0^\circ$

(b) $\sin \theta$ varies from +1 to -1, hence $3\sin \theta$ varies from +3 to -3

Thus the maximum value of $3\sin \theta - 1$ is $3 - 1 = 2$ and occurs when $\sin \theta = 1$ i.e. when $\theta = 90^\circ$

The minimum value of $3\sin \theta - 1$ is $-3 - 1 = -4$ and occurs when $\sin \theta = -1$ i.e. $\theta = 270^\circ$

Graphs of trigonometric functions

$y = \sin x$

the graph is continuous,

Ranges from -1 to 1 ($-1 \leq \sin x \leq 1$)

It is periodic i.e. it repeats itself every 360°

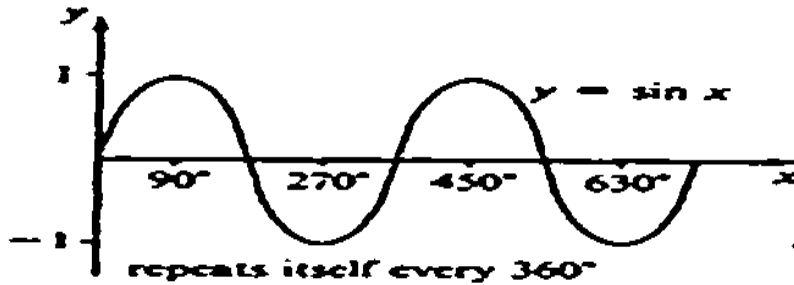

$y = \cos x$

The graph continuous,

Ranges from -1 to 1 ($-1 \leq \cos x \leq 1$)

It repeats itself every after 360°

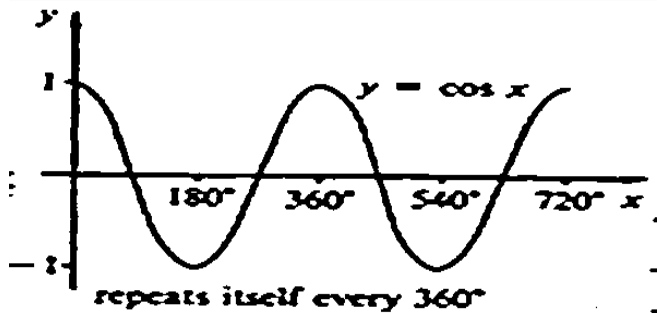

$y = \tan \theta$

The graph is not continuous being undefined when $\theta = 90^\circ, 270^\circ, 450^\circ$ etc.

Ranges from $-\infty$ to ∞ ($-\infty \leq \tan \theta \leq \infty$)

$\tan 0^\circ = \tan 180^\circ = \tan 360^\circ$

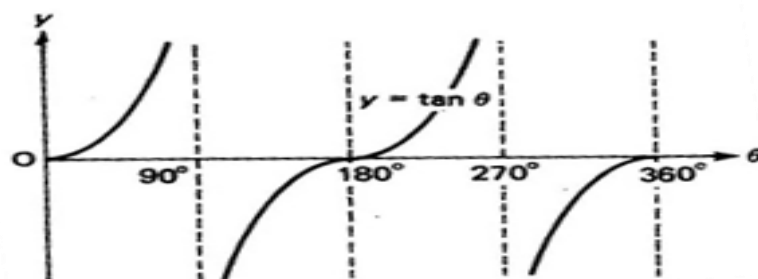

Solving trigonometrical equations**Example 1**

Solve the equation $\cos x = \frac{\sqrt{3}}{2}$ for values of x such that $0^\circ \leq x \leq 360^\circ$

Solution

The acute angle with a cosine of $\frac{\sqrt{3}}{2}$ is 30° , so solutions will make an angle of 30° with the x-axis.

The fact that the cosine is positive indicates that there are solutions in the 1st and 4th quadrants



For the range $0^\circ \leq x \leq 360^\circ$, $x = 30^\circ$ or 330°

Example 2

Solve the equation $\tan x = -\sqrt{3}$ for values of x such that $-180^\circ \leq x \leq 180^\circ$

Solution

We first ignore the minus sign and we find a tangent of $\sqrt{3}$. It is 60° and so the solutions will make an angle of 60° with the x-axis. Using the fact that tangent is negative indicate that there are solutions in the 2nd and 4th quadrants.



For the range $-180^\circ \leq x \leq 180^\circ$, $x = -60^\circ$ or 120°

Example 3

Solve the following equations for $0^\circ \leq x \leq 360^\circ$

(a) $\cos x = 0.2$ (b) $\sin x = -0.2$

Solution

(a) We require the acute angle with a cosine of 0.2. This is found either by using the inverse cosine function (written as \cos^{-1} or \arccos) on a calculator or by using cosine tables.

$\cos^{-1} 0.2 = 78.46^\circ$ ie solutions will make an angle of 78.46° with the x-axis.

Because the cosine is positive, solutions are found in the 1st and 4th quadrants. Thus the solutions can be sketched as shown below.



For the range $0^\circ \leq x \leq 360^\circ$, $x = 78.46^\circ$ or 281.54°

(b) We first ignore the minus sign in $\sin x = -0.2$

From a calculator or tables $\sin^{-1} 0.2 = 11.54^\circ$, ie solutions will make an angle of 11.54° with the x-axis.

Because sine is negative, solutions are found in the 3rd and 4th quadrants thus solutions can be sketched as below



For the range $0^\circ \leq x \leq 360^\circ$, $x = 191.54^\circ$ or 348.46°

Example 4

Solve $\cos x = -0.3$ for $-180^\circ \leq x \leq 180^\circ$

Solution

First ignore the minus sign,

$$\cos^{-1} 0.3 = 72.54^\circ \text{ from a calculator or tables}$$

Because the cosine is negative, the solutions are in the 2nd and 3rd quadrants. Thus, solutions can be sketched as shown.

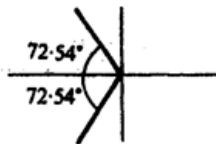

For a range of $-180^\circ \leq x \leq 180^\circ$, $x = 107.46^\circ$ or -107.46°

Example 5

Solve $\sin(x + 10^\circ) = -0.5$

Solution

$\sin^{-1} 0.5 = 30^\circ$ i.e. solutions will make an angle of 30° with the x-axis

Because sine is negative, solutions will be in the 3rd and 4th quadrants

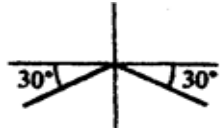

$$\begin{aligned} \text{Thus } x + 10^\circ &= 210^\circ \text{ or } x + 10^\circ = 330^\circ \\ x &= 200^\circ \text{ or } 320^\circ \end{aligned}$$

Example 6

Solve $3(\tan x + 1) = 2$ for $-180^\circ \leq x \leq 180^\circ$

Solution

Expanding $3 \tan x + 3 = 2$

$$\tan x = -\frac{1}{3}$$

$\tan^{-1} \frac{1}{3} = 18.43^\circ$, ie solutions will make an angle of 18.43° with the x-axis.

Because the tangent is negative, solutions are in the 2nd and 4th quadrants

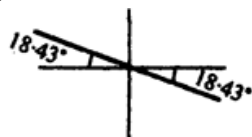

For $-180^\circ \leq x \leq 180^\circ$, $x = -18.43^\circ$ or 161.57°

Example 7

Solve $\sin^2 x + \sin x \cos x = 0$ for $0^\circ \leq x \leq 360^\circ$

Solution

Factorising $\sin x (\sin x + \cos x) = 0$

Thus Either $\sin x = 0$ or $\sin x + \cos x = 0$

$\sin^{-1} 0 = 0$ and solutions can be sketched



$$x = 0^{\circ}, 180^{\circ}, 360^{\circ}$$

$$\sin x = -\cos x$$

$$\tan x = -1 \quad (\text{on dividing by } \cos x)$$

$\tan^{-1} 1 = 45^{\circ}$ and because the tangent is negative, solutions will occur in the 2nd and 4th quadrants.

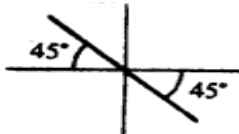

$$x = 135^{\circ} \text{ or } 315^{\circ}$$

Thus for the range $0^{\circ} \leq x \leq 360^{\circ}$; $x = 0^{\circ}, 135^{\circ}, 180^{\circ}, 315^{\circ}, 360^{\circ}$

Note:

It is important that we factorise $\sin^2 x + \sin x \cos x$ in the above example and do not attempt to cancel by $\sin x$. Cancelling will lead to $\sin x = -\cos x$ and so the solutions arising from $\sin x = 0$ would be lost.

Example 8

Solve the equation $4 \sin \theta = \tan \theta$ for $0^{\circ} \leq \theta \leq 360^{\circ}$

Solution

$$4 \sin \theta = \frac{\sin \theta}{\cos \theta}$$

$$4 \sin \theta \cos \theta = \sin \theta$$

$$4 \sin \theta \cos \theta - \sin \theta = 0$$

$$\sin \theta (4 \cos \theta - 1) = 0$$

Either $\sin \theta = 0$

$$\theta = 0^{\circ}, 180^{\circ} \text{ or } 360^{\circ}$$

$$\text{Or } 4 \cos \theta - 1 = 0$$

$$4 \cos \theta = 1$$

$$\cos \theta = \frac{1}{4}$$

$$\cos^{-1} \frac{1}{4} = 75.52,$$

cosine is positive so the angles will lie in the 1st and 4th quadrants

$$\theta = 75.52^{\circ} \text{ or } 284.48^{\circ}$$

$$\text{For } 0^{\circ} \leq \theta \leq 360^{\circ} = \{0^{\circ}, 75.52^{\circ}, 180^{\circ}, 284.48^{\circ}, 360^{\circ}\}$$

Example 9

Solve $6 \cos^2 x - \cos x - 1 = 0$ for $0^{\circ} \leq x \leq 360^{\circ}$

Solution

We need to first factorize the expression

$$6 \cos^2 x - 3 \cos x + 2 \cos x - 1 = 0$$

$$3 \cos x(2 \cos x - 1) + (2 \cos x - 1) = 0$$

$$(2 \cos x - 1)(3 \cos x + 1) = 0$$

Either $2 \cos x - 1 = 0$ or $3 \cos x + 1 = 0$

$$\cos x = \frac{1}{2}$$

$$\cos x = -\frac{1}{3}$$

Now $\cos^{-1} \frac{1}{2} = 60^\circ$ and because the cosine is positive, solutions lie in the 2nd and 3rd quadrants

$\cos^{-1} \frac{1}{3} = 70.53^\circ$ and because the cosine is positive, solutions lie in the 1st and 4th quadrants

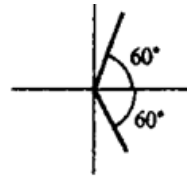
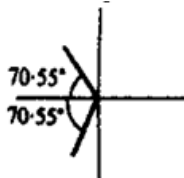

$$x = 109.47^\circ, 250.53^\circ$$

$$x = 60^\circ, 300^\circ$$

Thus for the range $0^\circ \leq x \leq 360^\circ$, $x = 60^\circ, 109.47^\circ, 250.53^\circ, 300^\circ$

Note: in some cases, factorizing can give a bracket that does not lead to any solutions. For example if we had to solve

$$(2 \cos x - 1)(\cos x - 2) = 0 \text{ for } 0^\circ \leq x \leq 360^\circ$$

Either $2 \cos x - 1 = 0$ or $\cos x - 2 = 0$

$$\cos x = \frac{1}{2}$$

$$\cos x = 2$$

giving $x = 60^\circ, 300^\circ$

which has no solutions

thus $x = 60^\circ$ or 300° are the only solutions

Example 9

Solve the equation $4 \cos x - 3 \sec x = 2 \tan x$ for $-180^\circ \leq x \leq 180^\circ$

Solution

$$4 \cos x - 3 \sec x = 2 \tan x$$

$$4 \cos x - \frac{3}{\cos x} = \frac{2 \sin x}{\cos x}$$

Multiplying through by $\cos x$ gives

$$4 \cos^2 x - 3 = 2 \sin x$$

$$4(1 - \sin^2 x) - 3 = 2 \sin x$$

$$4 \sin^2 x + 2 \sin x - 1 = 0$$

$$\sin x = \frac{-2 \pm \sqrt{(4+16)}}{8}$$

Hence $\sin x = 0.3090$ or -0.8090

Now $\sin^{-1}(0.3090) = 18^\circ$ and $\sin^{-1}(0.8090) = 54^\circ$

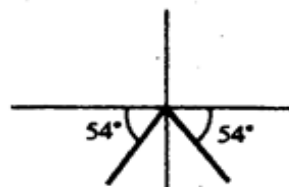
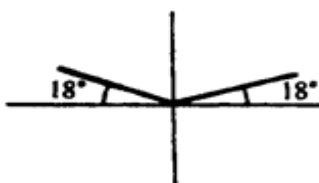

Thus for the range $-180^\circ \leq x \leq 180^\circ$, $x = -126^\circ, -54^\circ, 18^\circ, 162^\circ$

Note: The pythagorean identities we derived at the beginning of this chapter can be used to solve trigonometric equations as seen above and can also be used to prove other identities.

Example 1

Prove the identity $\tan^2 \theta + \sin^2 \theta = (\sec \theta + \cos \theta)(\sec \theta - \cos \theta)$

Solution

$$\begin{aligned} \text{R.H.S} &= (\sec \theta + \cos \theta)(\sec \theta - \cos \theta) \\ &= \sec^2 \theta - \sec \theta \cos \theta + \cos \theta \sec \theta - \cos^2 \theta \\ &= \sec^2 \theta - \cos^2 \theta \\ &= (1 + \tan^2 \theta) - (1 - \sin^2 \theta) \\ &= 1 + \tan^2 \theta - 1 + \sin^2 \theta \\ &= \tan^2 \theta + \sin^2 \theta = \text{L.H.S} \end{aligned}$$

Example 2

Prove that $\cot^4 \theta + \cot^2 \theta = \text{cosec}^4 \theta - \text{cosec}^2 \theta$

Solution

$$\begin{aligned} \text{L.H.S} &= \cot^4 \theta + \cot^2 \theta \\ &= \cot^2 \theta (\cot^2 \theta + 1) \\ &= (\text{cosec}^2 \theta - 1)(\text{cosec}^2 \theta) \quad \text{since } \text{cosec}^2 \theta = \cot^2 \theta + 1 \\ &= \text{cosec}^4 \theta - \text{cosec}^2 \theta = \text{R.H.S} \end{aligned}$$

Example 3

Prove the identity $\sqrt{\left(\frac{1-\cos \theta}{1+\cos \theta}\right)} = \text{cosec} \theta - \cot \theta$

Solution

$$\begin{aligned} \text{L.H.S} &= \sqrt{\left(\frac{1-\cos \theta}{1+\cos \theta}\right)} \\ &= \sqrt{\left(\frac{1-\cos \theta}{1+\cos \theta}\right) \left(\frac{1-\cos \theta}{1-\cos \theta}\right)} \\ &= \sqrt{\left[\frac{(1-\cos \theta)^2}{(1-\cos^2 \theta)}\right]} = \sqrt{\left[\frac{(1-\cos \theta)^2}{\sin^2 \theta}\right]} \\ &= \frac{1-\cos \theta}{\sin \theta} \\ &= \frac{1}{\sin \theta} - \frac{\cos \theta}{\sin \theta} \\ &= \text{cosec} \theta - \cot \theta = \text{R.H.S} \end{aligned}$$

The compound angle formulae

The compound angle formula gives the relationship between compound angles ie the sum and difference between two angles. Their proofs are not required at this level. They are as follows;

$$\begin{aligned} \sin(A + B) &= \sin A \cos B + \sin B \cos A \\ \sin(A - B) &= \sin A \cos B - \sin B \cos A \\ \cos(A + B) &= \cos A \cos B - \sin A \sin B \\ \cos(A - B) &= \cos A \cos B + \sin A \sin B \end{aligned}$$

Example 1

Evaluate the following with out using tables or a calculator (a) $\cos 75^\circ$ (b) $\sin 75^\circ$ (c) $\cos 15^\circ$ (d) $\sin 15^\circ$ (e) 330° (f) 240°

Solution

$$\begin{aligned} \text{(a) } \cos 75^\circ &= \cos(45^\circ + 30^\circ) \\ &= \cos 45^\circ \cos 30^\circ - \sin 45^\circ \sin 30^\circ \\ &= \frac{\sqrt{2}}{2} \times \frac{\sqrt{3}}{2} - \frac{\sqrt{2}}{2} \times \frac{1}{2} \\ &= \frac{\sqrt{6}}{4} - \frac{\sqrt{2}}{4} \\ \Rightarrow \cos 75^\circ &= \frac{\sqrt{6}-\sqrt{2}}{4} \end{aligned}$$

$$\begin{aligned} \text{(b) } \sin 75^\circ &= \sin(45^\circ + 30^\circ) \\ &= \sin 45^\circ \cos 30^\circ + \sin 30^\circ \cos 45^\circ \\ &= \frac{\sqrt{2}}{2} \times \frac{\sqrt{3}}{2} + \frac{\sqrt{2}}{2} \times \frac{1}{2} \\ &= \frac{\sqrt{6}}{4} + \frac{\sqrt{2}}{4} \\ \Rightarrow \sin 75^\circ &= \frac{\sqrt{6}+\sqrt{2}}{4} \end{aligned}$$

$$\begin{aligned} \text{(c) } \cos 15^\circ &= \cos(45^\circ - 30^\circ) \\ &= \cos 45^\circ \cos 30^\circ + \sin 45^\circ \sin 30^\circ \\ &= \frac{\sqrt{2}}{2} \times \frac{\sqrt{3}}{2} + \frac{\sqrt{2}}{2} \times \frac{1}{2} \\ &= \frac{\sqrt{6}}{4} + \frac{\sqrt{2}}{4} \\ \Rightarrow \sin 75^\circ &= \frac{\sqrt{6}+\sqrt{2}}{4} \end{aligned}$$

$$\begin{aligned} \text{(d) } \sin 15^\circ &= \sin(45^\circ - 30^\circ) \\ &= \sin 45^\circ \cos 30^\circ - \sin 30^\circ \cos 45^\circ \\ &= \frac{\sqrt{2}}{2} \times \frac{\sqrt{3}}{2} - \frac{\sqrt{2}}{2} \times \frac{1}{2} \\ &= \frac{\sqrt{6}}{4} - \frac{\sqrt{2}}{4} \\ \Rightarrow \sin 15^\circ &= \frac{\sqrt{6}-\sqrt{2}}{4} \end{aligned}$$

$$\begin{aligned} \text{(e) } \sin 330^\circ &= \sin(360^\circ - 30^\circ) \\ &= \sin 360^\circ \cos 30^\circ - \cos 360^\circ \sin 30^\circ \\ &= 0 \times \cos 30^\circ - (1) \times \sin 30^\circ \\ &= -\sin 30^\circ = -\frac{1}{2} \end{aligned}$$

$$\begin{aligned} \text{(e) } \cos 240^\circ &= \cos(180^\circ + 60^\circ) \\ &= \cos 180^\circ \cos 60^\circ - \sin 180^\circ \sin 60^\circ \\ &= (-1) \times \cos 60^\circ - 0 \times \sin 60^\circ \\ &= -\cos 60^\circ = -\frac{1}{2} \end{aligned}$$

Example 2

Given that α and β are acute angles with $\sin \alpha = \frac{7}{25}$ and $\cos \beta = \frac{5}{13}$, find with out using tables or calculator the values of (a) $\sin(\alpha + \beta)$ (b) $\cos(\alpha + \beta)$

Solution

we first sketch the two triangles to represent the given situations and get the remaining sides where necessary

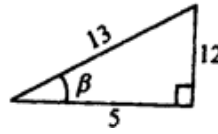
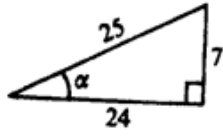

$$\text{Since } \sin \alpha = \frac{7}{25}, \cos \alpha = \frac{24}{25}$$

$$\text{since } \cos \beta = \frac{5}{13}, \sin \beta = \frac{12}{13}$$

$$(a) \sin(\alpha + \beta) = \sin \alpha \cos \beta + \sin \beta \cos \alpha$$

$$= \frac{7}{25} \times \frac{5}{13} + \frac{12}{13} \times \frac{24}{25}$$

$$= \frac{323}{325}$$

$$(b) \cos(\alpha + \beta) = \cos \alpha \cos \beta - \sin \alpha \sin \beta$$

$$= \frac{24}{25} \times \frac{5}{13} - \frac{7}{25} \times \frac{12}{13}$$

$$= \frac{120}{325} - \frac{84}{325}$$

$$= \frac{204}{325}$$

Example 3

Given that $\sin(x + 30^\circ) = \cos(x + 30^\circ)$. Show that $\tan x = \frac{\sqrt{3}-1}{\sqrt{3}+1}$

Solution

$$\sin x \cos 30^\circ + \sin 30^\circ \cos x = \cos x \cos 30^\circ - \sin x \sin 30^\circ$$

$$\frac{\sqrt{3}}{2} \sin x + \frac{1}{2} \cos x = \frac{\sqrt{3}}{2} \cos x - \frac{1}{2} \sin x$$

$$\sqrt{3} \sin x + \cos x = \sqrt{3} \cos x - \sin x \quad (\text{on multiplying through by } 2)$$

$$\sqrt{3} \sin x + \sin x = \sqrt{3} \cos x - \cos x$$

$$(\sin x)(\sqrt{3} + 1) = (\cos x)(\sqrt{3} - 1)$$

$$\frac{\sin x}{\cos x} = \frac{\sqrt{3}-1}{\sqrt{3}+1}$$

$$\tan x = \frac{\sqrt{3}-1}{\sqrt{3}+1}$$

Example 4

Solve the equation $\cos \theta \cos 20^\circ + \sin \theta \sin 20^\circ = 0.75$ for $0^\circ \leq x \leq 360^\circ$

Solution

$$\cos \theta \cos 20^\circ + \sin \theta \sin 20^\circ = 0.75$$

$$\cos(\theta - 20^\circ) = 0.75$$

$\cos^{-1}(0.75) = 41.41^\circ$ and because the cosine is positive, solutions are in the 1st and 4th quadrants



$$\Rightarrow \theta - 20^\circ = 41.41^\circ \text{ or } 318.59^\circ$$

$$\therefore \theta = 61.41^\circ \text{ or } 338.59^\circ$$

Example 5

Prove the following identities

$$(a) \sin(90^\circ - \theta) = \cos \theta \quad (b) \cos(180^\circ - \theta) = -\cos \theta$$

Solution

$$\begin{aligned} (a) \sin(90^\circ - \theta) &= \sin 90^\circ \cos \theta - \sin \theta \cos 90^\circ \\ &= (1) \cos \theta - (\sin \theta)(0) \\ &= \cos \theta \end{aligned}$$

$$\begin{aligned} (b) \cos(180^\circ - \theta) &= \cos 180^\circ \cos \theta + \sin 180^\circ \sin \theta \\ &= (1) \cos \theta + (0) \sin \theta = \cos \theta \end{aligned}$$

Example 6

Prve that $\cos(A + B) \cos(A - B) \equiv \cos^2 A - \sin^2 B$

Solution

$$\begin{aligned} \text{L.H.S} &= \cos(A + B) \cos(A - B) \\ &= (\cos A \cos B - \sin A \sin B)(\cos A \cos B + \sin A \sin B) \\ &= \cos^2 A \cos^2 B + \cos A \cos B \sin A \sin B - \sin A \sin B \cos A \cos B - \sin^2 A \sin^2 B \\ &= \cos^2 A \cos^2 B - \sin^2 A \sin^2 B \\ &= \cos^2 A (1 - \sin^2 B) - (1 - \cos^2 A)(\sin^2 B) \\ &= \cos^2 A - \cos^2 A \sin^2 B - \sin^2 B + \cos^2 A \sin^2 B \\ &= \cos^2 A - \sin^2 B = R.H.S \end{aligned}$$

The double angle formulae

The compound angle can be used to deduce the double angle formulae

Fom the identity $\sin(A + B) = \sin A \cos B + \sin B \cos A$

By putting $B = A$, we obtain

$$\begin{aligned} \sin(A + A) &= \sin A \cos A + \sin A \cos A \\ \sin 2A &= 2 \sin A \cos A \end{aligned}$$

Similarly by using $\cos(A + B) = \cos A \cos B - \sin A \sin B$

$$\begin{aligned} \cos(A + A) &= \cos A \cos A - \sin A \sin A \\ \cos 2A &= \cos^2 A - \sin^2 A \end{aligned}$$

$$\begin{aligned} \text{Putting } \cos^2 A &= 1 - \sin^2 A \\ \cos 2A &= 1 - \sin^2 A - \sin^2 A \\ &= 1 - 2 \sin^2 A \end{aligned}$$

$$\begin{aligned} \text{Putting } \sin^2 A &= 1 - \cos^2 A \\ \cos 2A &= \cos^2 A - (1 - \cos^2 A) \\ &= 2 \cos^2 A - 1 \end{aligned}$$

This results are reffered to as the double angle formulae because the angle on the left of the identity is double that on the right.

Thus we also have $\sin 8\theta = 2 \sin 4\theta \cos 4\theta$

$$\cos 4\theta = \cos^2 2\theta - \sin^2 2\theta \text{ etc.}$$

Example 1

Prove that (a) $\frac{\sin 2\theta}{1+\cos 2\theta} = \tan \theta$ (b) $\operatorname{cosec} 2\theta + \cot 2\theta \equiv \cot \theta$

Solution

$$\begin{aligned} \text{(a)} \quad \text{L.H.S} &= \frac{\sin 2\theta}{1+\cos 2\theta} \\ &= \frac{2 \sin \theta \cos \theta}{1+2 \cos^2 \theta - 1} \\ &= \frac{2 \sin \theta \cos \theta}{2 \cos^2 \theta} \\ &= \frac{\sin \theta}{\cos \theta} \\ &= \tan \theta = \text{R.H.S} \end{aligned}$$

$$\begin{aligned} \text{(b)} \quad \text{L.H.S} &= \operatorname{cosec} 2\theta + \cot 2\theta \\ &= \frac{1}{\sin 2\theta} + \frac{\cos 2\theta}{\sin 2\theta} \\ &= \frac{1+\cos 2\theta}{\sin 2\theta} \\ &= \frac{1+2 \cos^2 \theta - 1}{2 \sin \theta \cos \theta} \\ &= \frac{2 \cos^2 \theta}{2 \sin \theta \cos \theta} \\ &= \frac{\cos \theta}{\sin \theta} \\ &= \cot \theta = \text{R.H.S} \end{aligned}$$

Example 2

Simplify the following expressions

$$\text{(a)} \frac{\sin 2A}{\cos A} \quad \text{(b)} 2 \tan A \cos^2 A \quad \text{(c)} 2 \sin^2 A + \cos 2A$$

Solution

$$\begin{aligned} \text{(a)} \quad \frac{\sin 2A}{\cos A} &= \frac{2 \sin A \cos A}{\cos A} \\ &= 2 \tan A \end{aligned}$$

$$\begin{aligned} \text{(b)} \quad 2 \tan A \cos^2 A &= 2 \left(\frac{\sin A}{\cos A} \right) \cos^2 A \\ &= \frac{2 \sin A \cos^2 A}{\cos A} \\ &= 2 \sin A \cos A \\ &= \sin 2A \end{aligned}$$

$$\begin{aligned} \text{(c)} \quad 2 \sin^2 A + \cos 2A &= 2 \sin^2 A + \cos^2 A - \sin^2 A \\ &= \sin^2 A + \cos^2 A = 1 \end{aligned}$$

Example 3

Express $\sin 3A$ in terms of $\sin A$

$$\begin{aligned} \sin (3A) &= \sin (2A + A) \\ &= \sin 2A \cos A + \cos 2A \sin A \\ &= (2 \sin A \cos A) \cos A + (1 - 2 \sin^2 A) \sin A \\ &= 2 \sin A \cos^2 A + (1 - 2 \sin^2 A) \sin A \\ &= 2 \sin A (1 - \sin^2 A) + (1 - 2 \sin^2 A) \sin A \end{aligned}$$

$$= 2 \sin A - 2 \sin^3 A + \sin A - 2 \sin^3 A$$

$$= 3 \sin A - 4 \sin^3 A$$

Example 4

Solve the equation $5 \cos 2x + 9 \sin x = 7$ for $0^\circ \leq x \leq 360^\circ$

Solution

$$5 \cos 2x + 9 \sin x - 7 = 0$$

$$5(1 - 2 \sin^2 x) + 9 \sin x - 7 = 0$$

$$10 \sin^2 x - 9 \sin x + 2 = 0 \text{ which reduces to;}$$

$$10 \sin 2x - 5 \sin x - 4 \sin x + 2 = 0$$

$$5 \sin x (2 \sin x - 1) - 2(2 \sin x - 1) = 0$$

$$(5 \sin x - 2)(2 \sin x - 1) = 0$$

$$\text{Either } \sin x = \frac{1}{2} : x = 30^\circ \text{ or } 150^\circ$$

$$\text{Or } \sin x = \frac{2}{5} : x = 23.58^\circ \text{ or } 156.42^\circ$$

$$\text{For } 0^\circ \leq x \leq 360^\circ = \{23.58^\circ, 30^\circ, 150^\circ, 156.42^\circ\}$$

The solution of triangles

A triangle possesses six elements i.e. the three sides and the three angles. If any three elements (other than three angles) are given, the remaining three elements can be found. This is called solving the triangle

In solving the triangle, two geometrical facts are useful i.e.

1. In any triangle the sum of the angles is 180°
2. In any triangle, the largest side opposite the greater angle and the shortest side is opposite the angle

The sine rule

Consider a triangle ABC with sides a, b and c

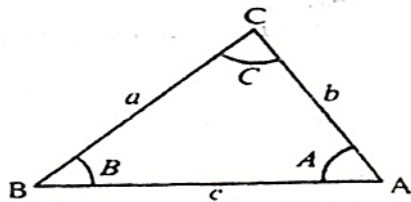

$$\text{Then } \frac{a}{\sin A} = \frac{b}{\sin B} = \frac{c}{\sin C}$$

This is the sine rule and should be memorized

Example 1

Find the length of the side BC in the given triangle

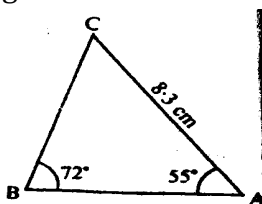

Solution

$$\begin{aligned} \text{By the sine rule, } \frac{BC}{\sin 55} &= \frac{8.3}{\sin 72} \\ BC &= \frac{8.3 \sin 55}{\sin 72} \\ BC &= 7.15 \text{ cm} \end{aligned}$$

Example 2

Find the angle x in the given triangle

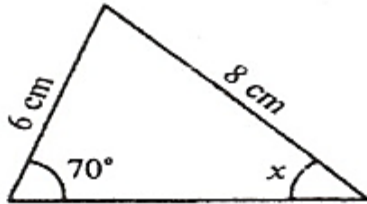
**Solution**

$$\begin{aligned} \text{By the sine rule, } \frac{8}{\sin 70} &= \frac{6}{\sin x} \\ \sin x &= \frac{6 \sin 70}{8} = 0.7048 \\ x &= \sin^{-1}(0.7048) = 44.81^\circ \end{aligned}$$

Example 3

Find the angle x in the given triangle

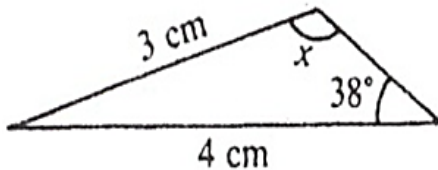
**Solution**

$$\begin{aligned} \text{By the sine rule, } \frac{3}{\sin 38} &= \frac{4}{\sin x} \\ \sin x &= \frac{4 \sin 38}{3} = 0.8209 \\ x &= \sin^{-1}(0.8209) = 55.17^\circ \end{aligned}$$

Example 4

In a triangle ABC, $A = 59^\circ$, $B = 39^\circ$ and $a = 6.73$ cm. Find the length of the smallest side. Find also the length of the remaining side.

Solution

First sketch the triangle

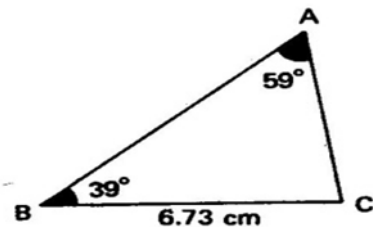

$$C = 180^\circ - (39^\circ + 59^\circ) = 82^\circ$$

The smallest side corresponds to the smallest angle which is 39°

By using the sine rule

$$\frac{b}{\sin 39} = \frac{6.73}{\sin 59}$$

$$b = \frac{6.73 \sin 39}{\sin 59}$$

$$b = 4.94 \text{ cm}$$

$$\frac{c}{\sin C} = \frac{6.73}{\sin 59} \text{ But } C = 82^\circ$$

$$c = \frac{6.73 \sin 82}{\sin 59}$$

$$c = 7.78 \text{ cm}$$

Example 5

In the triangle ABC, $A = 30^\circ$, $c = 10 \text{ cm}$ and $a = 7.5 \text{ cm}$. Solve the triangle

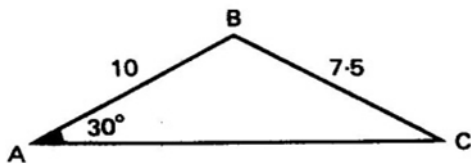
Solution

Let's use the sine rule to find C

$$\frac{7.5}{\sin 30} = \frac{10}{\sin C}$$

$$\sin C = \frac{10 \sin 30}{7.5}$$

$$\sin C = 0.6667$$

$$C = 41.81^\circ$$

Angle B can now be obtained from $A + B + C = 180^\circ$

$$B = 180^\circ - (30^\circ + 41.81^\circ)$$

$$B = 108.19^\circ$$

We can then obtain the remaining angle using the sine rule

$$\frac{b}{\sin 108.19} = \frac{7.5}{\sin 30}$$

$$b = \frac{7.5 \sin 108.19}{\sin 30}$$

$$b = 14.25 \text{ cm}$$

Example 6

In the triangle ABC, $B = 40^\circ$, $c = 8 \text{ cm}$ and $b = 12 \text{ cm}$. Find the length of side a.

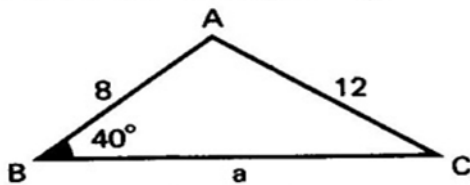
Solution

Using the sine rule

$$\frac{8}{\sin C} = \frac{12}{\sin 40}$$

$$\sin C = \frac{8 \sin 40}{12}$$

$$\sin C = 0.4285$$

$$C = 25.37^\circ$$

$$\text{Angle } A = 180 - (40 + 25.37)$$

$$A = 114.63^\circ$$

Using the sine rule again;

$$\frac{a}{\sin 114.63} = \frac{12}{\sin 40}$$

$$a = \frac{12 \sin 114.63}{\sin 40}$$

$$a = 16.97 \text{ cm}$$

The cosine rule

Consider the triangle below

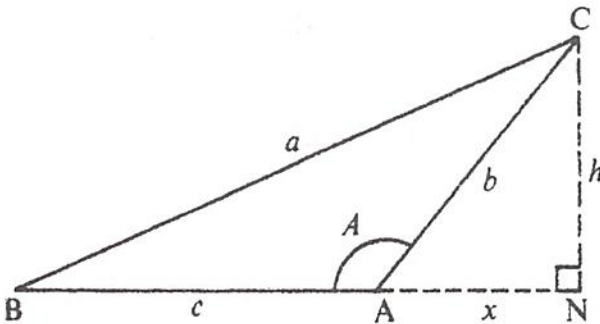

Using Pythagoras theorem

$$\triangle CBN \quad a^2 = h^2 + (c+x)^2$$

$$\triangle CAN \quad b^2 = h^2 + x^2$$

Eliminating h^2 gives;

$$a^2 = b^2 - x^2 + (c+x)^2$$

$$\text{So } a^2 = b^2 + c^2 + 2cx$$

$$\text{But from } \triangle ANC, x = b \cos (180^\circ - A)$$

$$= -b \cos A$$

$$\text{Hence } a^2 = b^2 + c^2 - 2bc \cos A$$

Thus if we consider a triangle ABC with sides a, b and c

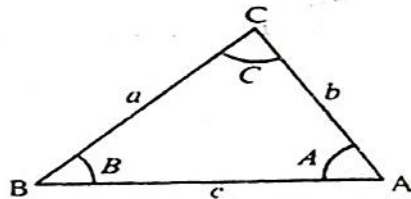

Then;

$$a^2 = b^2 + c^2 - 2bc \cos A$$

$$b^2 = a^2 + c^2 - 2ac \cos B$$

$$c^2 = b^2 + a^2 - 2ab \cos C$$

This is the cosine rule and it should be memorized because it is frequently used to determine side or angle of a given triangle

Example 1

Find the length of the side BC in each of the following triangles

(a)

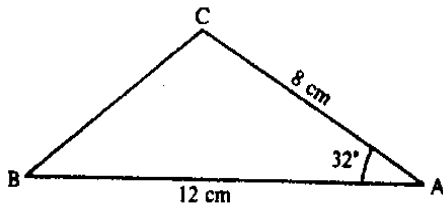
**Solution**

By cosine rule

$$\begin{aligned} BC^2 &= 12^2 + 8^2 - 2(12)(8) \cos 32^\circ \\ &= 144 + 64 - 192(0.8480) \\ &= 208 - 162.8 = 45.2 \end{aligned}$$

$$BC = \sqrt{45.2}$$

giving $BC = 6.72$ cm

b)

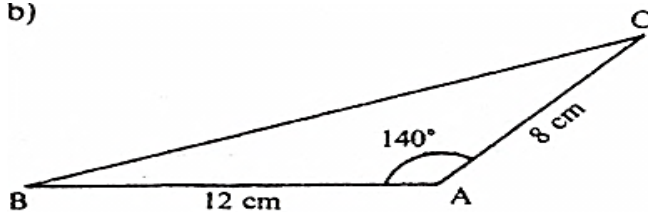
**Solution**

By cosine rule

$$\begin{aligned} BC^2 &= 12^2 + 8^2 - 2(12)(8) \cos 140^\circ \\ &= 144 + 64 - 192(-0.7660) \\ &= 208 + 147.1 = 355.1 \end{aligned}$$

$$BC = \sqrt{355.1}$$

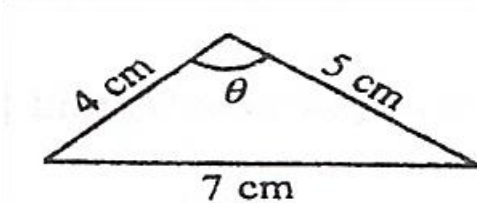
giving $BC = 18.8$ cm**Example 2**Find the angle θ in the triangle below**Solution**

By cosine rule

$$7^2 = 5^2 + 4^2 - 2(4)(5) \cos \theta$$

$$\cos \theta = \frac{25 + 16 - 49}{40}$$

$$\cos \theta = -0.2$$

$$\theta = \cos^{-1}(-0.2)$$

$$\theta = 101.54^\circ$$

Example 3

In the triangle XYZ, $YZ = 6.7\text{ cm}$, $XY = 2.3\text{ cm}$ and , $\text{angle } XYZ = 46.53^\circ$. Calculate angle XZY

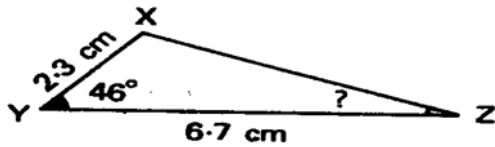
Solution

From the cosine rule

$$\begin{aligned} XZ^2 &= YZ^2 + XY^2 - 2(YZ)(XY) \cos(XYZ) \\ &= 6.7^2 + 2.3^2 - 2(6.7)(2.3) \cos 46.53 \\ &= 44.89 + 5.29 - 21.20 \\ &= 28.98 \end{aligned}$$

$$XZ = 5.383 \text{ cm}$$

Now by using the sine rule;

$$\begin{aligned} \frac{XY}{\sin XZY} &= \frac{XZ}{\sin XYZ} \\ \sin XZY &= \frac{XY \sin XYZ}{XZ} \\ &= \frac{2.3 \sin 46.53}{5.383} = 0.3101 \\ XZY &= 18.06^\circ \end{aligned}$$

Example 4

In a triangle PQR, $PR = 40\text{ cm}$, $PQ = 50\text{ cm}$, angle $QPR = 66^\circ$. Calculate the length of side QR and angles PQR and QRP.

Solution

$$\begin{aligned} QR^2 &= PQ^2 + PR^2 - 2(PR)(PQ) \cos(RPQ) \\ &= 50^2 + 40^2 - 2(40)(50) \cos 66 \\ &= 2500 + 1600 - 4000(\cos 66) \\ &= 2373.05 \end{aligned}$$

$$QR = \sqrt{2373.05}$$

$$QR = 48.71 \text{ cm}$$

By using the sine rule, we can obtain angle PQR

$$\begin{aligned} \frac{40}{\sin PQR} &= \frac{48.71}{\sin 66} \\ \sin PQR &= \frac{40 \sin 66}{48.71} = 0.7502 \\ PQR &= 48.61^\circ \end{aligned}$$

Using $A + B + C = 180^\circ$, we obtain the remaining angle QRP

$$\begin{aligned} QRP &= 180^\circ - (66^\circ + 48.61^\circ) \\ &= 65.39^\circ \end{aligned}$$

The area of a triangle

The area of a triangle is found from the formula;

$$\text{Area} = \frac{1}{2} \times \text{base} \times \text{Altitude}$$

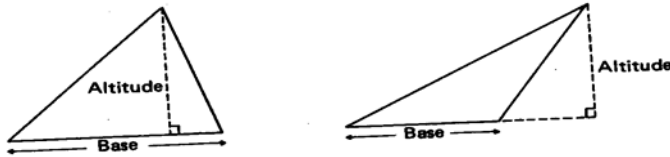

A triangle ABC has a perpendicular drawn from A to the side BC

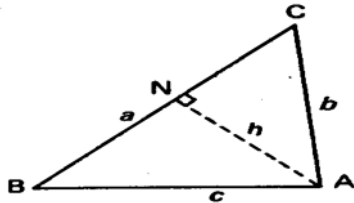

If h is the length of the perpendicular, then $h = b \sin C$ or $c \sin B$ from the triangles ACN and ABN.

$$\begin{aligned} \text{New area of triangle} &= \frac{1}{2} ah \\ &= \frac{1}{2} ab \sin C \\ &= \frac{1}{2} ac \sin B \end{aligned}$$

Similarly it can be shown that the area equals to $\frac{1}{2} bcsin A$. The area of a triangle is usually represented by the symbol Δ .

Example 1

Find the area of the triangle below

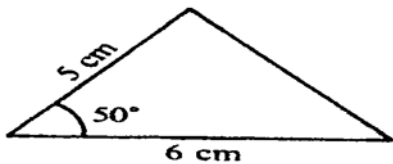
**Solution**

$$\begin{aligned} \text{Area} &= \frac{1}{2} \times 5 \times 6 \times \sin 50 \\ &= 11.5 \text{ cm}^2 \end{aligned}$$

Example 2

In the triangle ABC, $AB = 5 \text{ cm}$, $BC = 6 \text{ cm}$ and angle $ABC = 60^\circ$. Find the area of the triangle ABC.

Solution

$$\begin{aligned} \text{Area } \Delta ABC &= \frac{1}{2} ac \sin B \\ &= \frac{1}{2} \times 6 \times 5 \sin 60 \\ &= 15 \times 0.8660 = 12.99 \text{ cm}^2 \end{aligned}$$

Example 3

Given triangle ABC in which $AB = 4 \text{ cm}$, $a = 7 \text{ cm}$ and $AC = 5 \text{ cm}$. Find the

- (i) Angle ABC

(ii) Area of triangle ABC

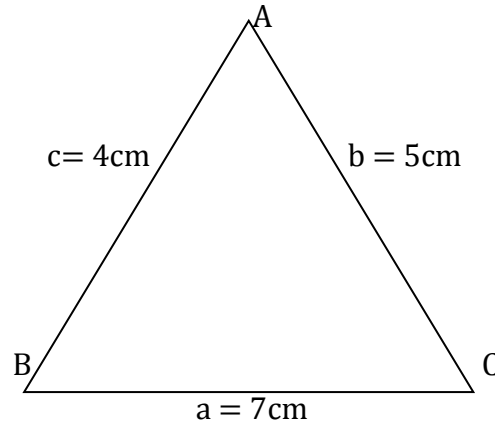
Solution(i) By using cosine rule : $b^2 = a^2 + c^2 - 2ac \cos B$

$$\begin{aligned}\cos B &= \frac{a^2 + c^2 - b^2}{2ac} \\ &= \frac{7^2 + 4^2 - 5^2}{2 \times 7 \times 4} \\ &= \frac{40}{56}\end{aligned}$$

$$\cos B = 0.71432$$

$$B = \cos^{-1}(0.7141432)$$

$$B = 44.4^\circ$$

(ii) Area of DABC = $\frac{1}{2} a c \sin B$, where B is the included angle

$$\begin{aligned}\text{Area of ABC} &= \frac{1}{2} \times 7 \times 4 \times \sin 44.4 \\ &= 14 \times 0.6997\end{aligned}$$

$$\text{Area of DABC} = 9.796 \text{ cm}^2$$

Note: Since we are given all the three sides, the area of this triangle can also be obtained from hero's formula, as we shall see.

Example 4

The area of triangle ABC is $20\sqrt{3} \text{ cm}^2$, $A = 60^\circ$ and $b = 8 \text{ cm}$. Find the length of side a.

Solution

$$\Delta = \frac{1}{2} b c \sin A$$

$$c = \frac{2\Delta}{b \sin A}$$

$$c = \frac{2 \times 20\sqrt{3}}{8 \times \sin 60}$$

$$c = 10 \text{ cm}$$

$$\text{From } a^2 = b^2 + c^2 - 2bc \cos A$$

$$= 8^2 + 10^2 - 2(8)(10) \cos 60$$

$$a^2 = 84$$

$$a = 9.17 \text{ cm}$$

Hero's formula

Using Hero's formula, the area of a triangle can be found from three sides in a triangle ABC as below;

$$\text{Area} = \sqrt{s(s-a)(s-b)(s-c)}$$

where the sides are a, b and c and s is the semi perimeter gotten from $s = \frac{1}{2}(a + b + c)$

Example 1

The sides of a triangle are a = 12.7 cm, b = 13.9 cm, c = 8.6 cm. Calculate the area of the triangle.

Solution

$$\text{Semi perimeter} = \frac{1}{2}(12.7 + 13.9 + 8.6) = 17.6$$

$$s - a = 17.6 - 12.7 = 4.9$$

$$s - b = 17.6 - 13.9 = 3.7$$

$$s - c = 17.6 - 8.6 = 9.0$$

$$\begin{aligned} \text{Area} &= \sqrt{s(s-a)(s-b)(s-c)} \\ &= \sqrt{17.6 \times 4.9 \times 3.7 \times 9} \\ &= 53.59 \text{ cm}^2 \end{aligned}$$

Example 2

Find the area of the triangle shown below

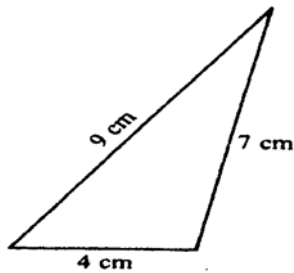
**Solution**

$$s = \frac{4+7+9}{2} = 10$$

$$\begin{aligned} \text{Area} &= \sqrt{10(10-4)(10-7)(10-9)} \\ &= \sqrt{180} = 13.4 \text{ cm}^2 \end{aligned}$$

SUMMARY

Sine Rule: $\frac{a}{\sin A} = \frac{b}{\sin B} = \frac{c}{\sin C} = 2R.$

Cosine Rule: $a^2 = b^2 + c^2 - 2bc \cos A$ (and two other similar formulae)

Solution of triangles;

I Given two sides (b, c) and included angle (A).

Use cosine rule to find a .

Then use sine rule to find B or C .

Angle sum ($= 180^\circ$) gives third angle.

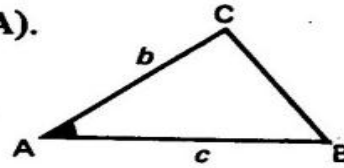

II Given three sides.

Use cosine rule to find any angle.

Then use sine rule to find second angle.

Angle sum gives third angle.

III Given two angles and one side.

Angle sum gives third angle.

Sine rule, used twice, gives other two sides.

IV Given two sides (a, c) and non-included angle (A).

Use sine rule to find second angle (C).

One solution if A is obtuse and $a > c$.

One solution if A is acute and $a > c$.

Two solutions (ambiguous case) if A is acute and $c \sin A < a < c$.

One solution if A is acute and $c \sin A = a$.

No solution if A is acute and $c \sin A > a$.

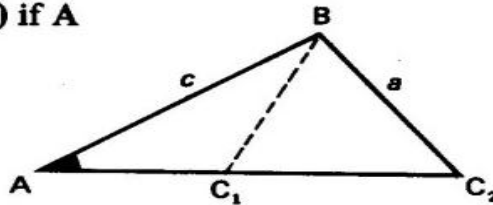

Area of a triangle (Δ) $= \frac{1}{2}$ (base) (height)

$$= \frac{1}{2} ab \sin C = \frac{1}{2} ac \sin B = \frac{1}{2} bc \sin A$$

$$= \sqrt{s(s-a)(s-b)(s-c)} \text{ where } 2s = a + b + c.$$

Trial questions

1. Solve the following equations for the values of x between 0° and 360°

(a) $5\cos x = \cot x$ [Ans : $11.53^\circ, 90^\circ, 168.47^\circ, 270^\circ$]

(b) $3 \tan x = 2\sec x$ [Ans : $41.82^\circ, 138.18^\circ$]

(c) $\sin^2 x = \frac{1}{4}$ [Ans : $30^\circ, 150^\circ, 210^\circ, 330^\circ$]

(d) $\tan^2 x = \frac{1}{3}$ [Ans: $30^\circ, 150^\circ, 210^\circ, 330^\circ$]

(e) $2\cos^2 x + 3\cos x + 1 = 0$ [Ans: $120^\circ, 180^\circ, 240^\circ$]

(f) $\cos^2 x + \sin x + 1 = 0$ [Ans : 270°]

(g) $2\cot^2 \theta + \tan \theta - 3 = 0$ [Ans : $30^\circ, 41.82^\circ, 138.18^\circ, 150^\circ$]

(h) $\sec^2 x - 3 \tan x + 1 = 0$ [Ans: $45^\circ, 63^\circ, 43^\circ, 225^\circ, 243^\circ, 43^\circ$]

(i) $2\cot x + \tan x - 3 = 0$ [Ans : $45^\circ, 63.43^\circ, 225^\circ, 243.43^\circ$]

(j) $2 \sin^2 x + 3 \sin x = 2$ [Ans : $30^\circ, 150^\circ$]

2. Show that $\cos(x + 120^\circ) + \cos(x + 240^\circ) = 0$

3. Prove the following identities

(a) $\frac{\sin \theta}{1 + \cos \theta} + \frac{1 + \cos \theta}{\sin \theta} = 2 \operatorname{cosec} \theta$

(b) $\frac{\operatorname{cosec} \theta}{\cot \theta + \tan \theta} = \cos \theta$

(c) $\sec^4 \theta - \sec^2 \theta = \tan^4 \theta + \tan^2 \theta$

4. A and B are acute angles such that $\sin A = \frac{12}{13}$ and $\cos B = \frac{4}{5}$. Without using tables or calculator, find the values of (a) $\sin(A - B)$ (b) $\cos(A - B)$ [Ans: (a) $\frac{33}{65}$ (b) $\frac{56}{65}$]

5. C and D are both obtuse angles such that $\sin C = \frac{3}{5}$ and $\sin D = \frac{5}{13}$. Without the use of tables or calculator, find the values of (a) $\sin(C + D)$ (b) $\cos(C - D)$ [Ans: (a) $-\frac{56}{65}$ (b) $\frac{63}{65}$]

6. In the triangle ABC, $AB = 15$ cm, $BC = 6$ cm and angle ABC is 60° find

(i) AC

(ii) The remaining angles of the triangle

(iii) Area of triangle ABC

(Ans: AC = 5.57 cm, 51.1° , 68.9° , area = 12.99 cm^2)

7. Prove the following identities

(a) $\cos(90^\circ + \theta) = -\sin \theta$

(b) $\sin(A + B) + \sin(A - B) = 2 \sin A \sin B$

(c) $\sin(90^\circ + \theta) = \cos \theta$

(d) $\cos(A + B) - \cos(A - B) = -2 \sin A \sin B$

(e) $\sin(A + B) \sin(A - B) = \sin^2 A - \sin^2 B$

(f) $\sin(\alpha + 30^\circ) = \cos \alpha + \sin(\alpha - 30^\circ)$

(g) $\sin \theta \tan \theta + \cos \theta = \sec \theta$

(h) $\operatorname{cosec} \theta - \sin \theta = \cot \theta \cos \theta$

(i) $(\sin \theta + \cos \theta)^2 + (\sin \theta - \cos \theta)^2 = 2$

8. If A and B are acute angles such that $\sin A = 0.28$ and $\cos B = 0.8$, find without using tables or a calculator the values of:

(a) $\sin(A + B)$ (b) $\cos(A - B)$ [Ans: (a) 0.8 (b) 0.936]

9. Solve the following equations for $0^\circ \leq x \leq 360^\circ$

(a) $\sin \theta \cos 10^\circ + \cos \theta \sin 10^\circ = -0.5$ [Ans: $200^\circ, 320^\circ$]

(b) $\cos 40^\circ \cos \theta - \sin 40^\circ \sin \theta = 0.4$ [Ans: $26.4^\circ, 253.6^\circ$]

(c) $\sin(\theta + 45^\circ) = \sqrt{2} \cos \theta$ [Ans: $45^\circ, 225^\circ$]

10. Solve the triangle ABC given that $A = 66^\circ, C = 44^\circ$, and $a = 7$ cm

[Ans: $B = 70^\circ, c = 5.32$ cm, $b = 7.2$ cm]

11. Solve the triangle ABC given that $A = 45^\circ, c = 5$ cm and $b = 6$ cm.

[Ans: $a = 4.31$ cm, $C = 55.1^\circ, B = 79.9^\circ$]

12. Solve the triangle ABC given that $C = 50^\circ, c = 8$ cm and $a = 10$ cm

[Ans: $A = 73.2^\circ, B = 56.8^\circ, b = 8.73$ cm or $A = 106.8^\circ, B = 23.2^\circ, b = 4.12$ cm]

13. Find the length of x in each of the following

(a)

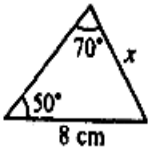

(b)



(c)

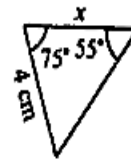

(d)

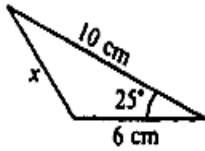

(e)

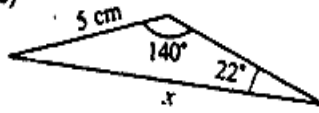

(f)

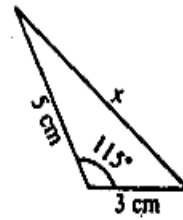

[Ans: (a) 6.52 cm (b) 5.57 cm (c) 3.74 cm (d) 5.22 cm (e) 8.57 cm (f) 6.83 cm]

14. Find the angle θ in each of the following

(a)

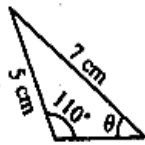

(b)

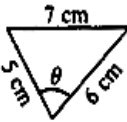

(c)

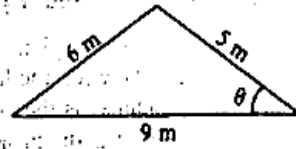

(d)

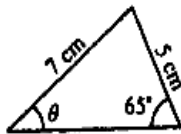

(e)

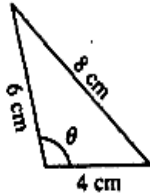

(f)

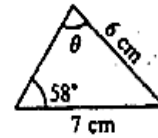

[Ans: (a) 42.2° (b) 78.5° (c) 38.9° (d) 40.3° (e) 104.5° (f) 81.6° or 98.4°]

15. Find the areas of the following triangles

(a)

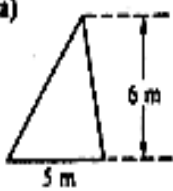

(b)

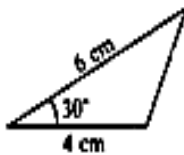

(c)

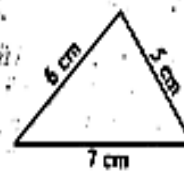

(d)

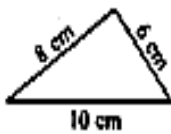

(e)

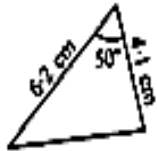

(f)

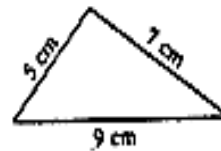

[Ans: (a) 15 m^2 (b) 6 cm^2 (c) 14.7 cm^2 (d) 24 cm^2 (e) 9.74 cm^2 (f) 17.4 cm^2]

CHAPTER 10: DIFFERENTIAL EQUATIONS

A Differential equation is an equation that contains at least one differential coefficient e.g.

$$\frac{dy}{dx} = 3x$$

$$\frac{d^2y}{dx^2} + 4x \frac{dy}{dx} = 6$$

Order of a differential equation

The order of a differential equation is the highest derivative, which appears in it for instance;

The equation $\frac{dy}{dx} - 4x = 3$ is a first order differential equation because it contains only a first differential coefficient, $\frac{dy}{dx}$

The equation $\frac{d^2y}{dx^2} + 3 \frac{dy}{dx} = 9$ is a second order differential equation because it contains a second differential coefficient, $\frac{d^2y}{dx^2}$.

Note: Any differential equation represents a relationship between two variables say x and y and the same relationship can often be expressed in a form that does not contain a differential coefficient e.g. $y = x^2 + c$ and $\frac{dy}{dx} = 2x$

Solution of a differential equation

The solution of a differential equation is an equation relating the variables involved but containing no differential coefficient like $\frac{dy}{dx}$. There are two types of solutions

- (i) The general solution
It contains an arbitrary constant
- (ii) Particular solution
It may be obtained if the "x-value" and the corresponding "y-value" are given. These are called initial conditions and are used to calculate the constant.

Consider $\frac{dy}{dx} = 3x^2$; This is a first order differential equation

By separating variables

$$dy = 3x^2 dx$$

Integrating on both sides

$$\int dy = \int 3x^2 dx$$

$$y = x^3 + c \quad \text{This is a general solution}$$

If $x = 1$, when $y = 2$ (these are initial conditions)

$$2 = 1 + c$$

$$\Rightarrow c = 1$$

$$\therefore y = x^3 + 1 \quad \text{(This is a particular solution)}$$

Separable Differential Equations

We are now going to start to look at the first order differential equations with separable variables

A separable differential equation is any differential equation that we can write in the following form.

$$N(y) \frac{dy}{dx} = M(x)$$

Note that in order for a differential equation to be separable all the y's in the differential equation must be multiplied by the derivative and all the x's in the differential equation must be on the other side of the equal sign.

Solving separable differential equation is fairly easy. We first rewrite the differential equation as the following

$$N(y) dy = M(x) dx$$

Then you integrate both sides.

$$\int N(y) dy = \int M(x) dx$$

Examples

1. Find the general solutions of the following differential equations

(a) $3y \frac{dy}{dx} = 5x^2$

Solution

By separating variables ie by separating dy from dx and collecting on one side all terms involving y together with dy, while all the x terms together with dx, it gives;

$$3y dy = 5x^2 dx$$

We now integrate both sides of the equation

$$\int 3y dy = \int 5x^2 dx$$

$$\frac{3y^2}{2} = \frac{5x^3}{3} + c$$

(b) $u \frac{du}{dv} = v + 2$

Solution

$$u du = (v + 2) dv$$

Integrating on both sides;

$$\int u du = \int (v + 2) dv$$

$$\frac{u^2}{2} = \frac{v^2}{2} + v + c$$

(c) $\frac{dy}{dx} = y^2$

solution

$$\frac{1}{y^2} dy = dx$$

$$\int y^{-2} dy = \int dx$$

$$-y^{-1} = x + c$$

$$-\frac{1}{y} = x + c$$

(d) $\frac{1}{x} \frac{dy}{dx} = \frac{1}{y^2 - 2}$

Solution

By separating the variables;

$$(y^2 - 2) dy = x dx$$

Integrating on both sides

$$\int (y^2 - 2) dy = \int x dx$$

$$\frac{y^3}{3} - 2y = \frac{x^2}{2} + c$$

(e) $\frac{dy}{dx} = x^2 - 2x$

Solution

$$dy = (x^2 - 2x) dx$$

$$\int dy = \int (x^2 - 2x) dx$$

$$y = \frac{x^3}{3} - x^2 + c$$

2. Find the particular solutions of the following differential equations

(a) $y^2 \frac{dy}{dx} = x^2 + 1$ if $y=1$ when $x=2$

Solution

$$y^2 dy = (x^2 + 1) dx$$

$$\int y^2 dy = \int (x^2 + 1) dx$$

$$\frac{y^3}{3} = \frac{x^3}{3} + x + c$$

This is a general solution but since the initial condition is given, we can calculate the constant i.e.

$$\frac{(1)^3}{3} = \frac{(2)^3}{3} + 2 + c \text{ which gives } c = -\frac{13}{3}$$

Therefore $\frac{y^3}{3} = \frac{x^3}{3} + x - \frac{13}{3}$ is the particular solution

(b) $\frac{dy}{dx} = 6y^2x$ if $y = \frac{1}{25}$ when $x = 1$

Solution

$$y^{-2} dy = 6x dx$$

$$\int y^{-2} dy = \int 6x dx$$

$$-\frac{1}{y} = 3x^2 + c$$

So, we now have the general solution. This solution is easy enough to get the particular solution, however before getting that it is usually easier to find the value of the constant at this point. So apply the initial condition and find the value of c .

$$-\frac{1}{\frac{1}{25}} = 3(1)^2 + c \quad c = -28$$

Plug this into the general solution and then solve to get the particular solution.

$$-\frac{1}{y} = 3x^2 - 28$$

(c) $\frac{dy}{dx} = \frac{3x^2 + 4x - 4}{2y - 4}$ if $y = 3$ when $x = 1$

Solution

This differential equation is clearly separable, so let's put it in the proper form and then integrate both sides.

$$(2y-4)dy = (3x^2 + 4x - 4)dx$$

$$\int (2y-4)dy = \int (3x^2 + 4x - 4)dx$$

$$y^2 - 4y = x^3 + 2x^2 - 4x + c$$

We now have our general solution, so as with the first example let's apply the initial condition at this point to determine the value of c .

$$(3)^2 - 4(3) = (1)^3 + 2(1)^2 - 4(1) + c \quad c = -2$$

The particular solution is then;

$$y^2 - 4y = x^3 + 2x^2 - 4x - 2$$

Natural occurrences of differential equations

Differential equations often arise when a physical situation is interpreted mathematically (i.e. when a mathematical model is made of the physical situation). Differential equations are used to solve applied problems such as those involving carbon dating and radioactive decay; the amount of drug in an organ; mixtures; supply and demand; logistic growth and marginal productivity.

Example 1

A body moves with a velocity v , which is inversely proportional to its displacement s from a fixed point. Form a differential equation to represent the information

Solution

Velocity is the rate of change of displacement with respect to time

$$v \propto \frac{1}{s}$$

$$v = \frac{k}{s} \text{ where } k \text{ is a constant}$$

$$\text{but } v = \frac{ds}{dt}$$

$$\Rightarrow \frac{ds}{dt} = \frac{k}{s}$$

$$s \frac{ds}{dt} = k \text{ is the differential equation}$$

Example 2

A particle moves in a straight line with an acceleration that is inversely proportional to its velocity (acceleration is the rate of change of velocity)

(a) Form the differential equation to represent this data

(b) Given that the acceleration is 2 m/s^2 when the velocity is 5 m/s , solve the differential equation

Solution

(a) Using $\frac{dv}{dt}$ for acceleration, we have;

$$\frac{dv}{dt} \propto \frac{1}{v}$$

$$\Rightarrow \frac{dv}{dt} = \frac{k}{v}$$

$$(b) \text{ If } v = 5, \frac{dv}{dt} = 2$$

$$\text{Then } 2 = \frac{k}{5} \Rightarrow k = 10$$

$$\frac{dv}{dt} = \frac{10}{v}$$

$$v \, dv = 10 \, dt$$

$$\int v \, dv = \int 10 \, dt$$

$$\frac{v^2}{2} = 10t + c$$

Example 3

The rate of change of the price with respect to time is inversely proportional to the current Price, P. Form a differential equation to represent the above information and solve it.

Solution

$$\frac{dP}{dt} \propto \frac{1}{P}$$

$$\frac{dP}{dt} = \frac{k}{P}$$

$$P \, dP = k \, dt$$

$$\int P \, dP = \int k \, dt$$

$$\frac{P^2}{2} = kt + c$$

Trial questions

1. Solve the differential equation $\frac{dy}{dx} = 3x^2y^2$ given that $y = 1$ when $x = 0$ [Ans: $x^3y = y - 1$]

2. Find the general solution of the differential equation $6t \frac{dt}{ds} + 1 = 0$, and the particular solution given by the condition $s = 0$ when $t = -2$ [ans: $s = -3t^2 + c, s = 12 - 3t^2$]

3. Find the general solutions of the following differential equations

(a) $\frac{dy}{dx} = 3x$

(b) $2y \frac{dy}{dx} = 3$

(c) $\frac{dy}{dx} = \frac{x-4}{4y^3}$

(d) $\frac{dy}{dx} = -\frac{x}{y}$

(e) $\frac{dy}{dx} = y^{\frac{4}{5}}$

[Ans: (a) $y = \frac{3x^2}{2} + c$ (b) $y^2 = 3x + c$ (c) $y^4 = \frac{x^2}{2} - 4x + c$ (d) $\frac{y^2}{2} = \frac{-x^2}{2} + c$ (e) $5y^{\frac{1}{5}} = x + c$]

4. Find the particular solution of the differential equation $\frac{dx}{dt} = t$ where $x = 3$ when $t = 1$.

[Ans: $x = \frac{t^2}{2} + \frac{5}{2}$]

5. The rate of change of y with respect to x is proportional to the square of x . Write a differential equation that models this statement. [Ans: $\frac{dy}{dx} = kx^2$]

CHAPTER 11: DESCRIPTIVE STATISTICS

This is the branch of mathematics dealing with collection, interpretation, presentation and analysis of data where data refers to the facts in the day-to-day life. Statistical data can be categorized into two .i.e. Qualitative and Quantitative.

Qualitative data measures attributes such as sex, colour, and so on while Quantitative data can be represented by numerical quantity. Quantitative data is of two forms. i.e. Continuous or discrete.

Discrete data is the information collected by counting and usually takes on integral values e.g. number of students in a class, school etc.

Continuous data can take on any value i.e. weight, height, mass, etc. The quantity which is counted or measured is called the variable.

Crude/raw/ungrouped data

These are individual values of a variable in no particular order of magnitude, written down as they occurred or were measured.

Grouped /classified data

These are individual values of a variable that have been arranged in order and grouped in small number of classes.

Population and samples

A population is a total set of Items under consideration and its defined by some characteristics of these items.

A sample is a finite subset of a population.

PRESENTATION OF DATA

The ways of presenting data include:

- Bar graphs
- Histogram
- Frequency Polygon
- The Ogive
- Pie chart

BAR GRAPH

A bar graph or bar chart is a graph where the class frequencies are plotted against class limits.

HISTOGRAM

A histogram is a graph where the class frequencies are plotted versus class boundaries.

Example 1

The times taken by rats to pass through a maze are recorded in the table below. Use the data given to plot a bar graph and histogram.

Time(seconds)	10-14	15-19	20-24	25-29	30-34	35-39
Frequency	3	11	19	22	6	2

Solution

Class limits	Class boundaries	Frequency
10-14	9.5-14.5	3
15-19	14.5-19.5	11
20-24	19.5-24.5	19
25-29	24.5-29.5	22
30-34	29.5-34.5	6
35-39	34.5-39.5	2

Bar graph

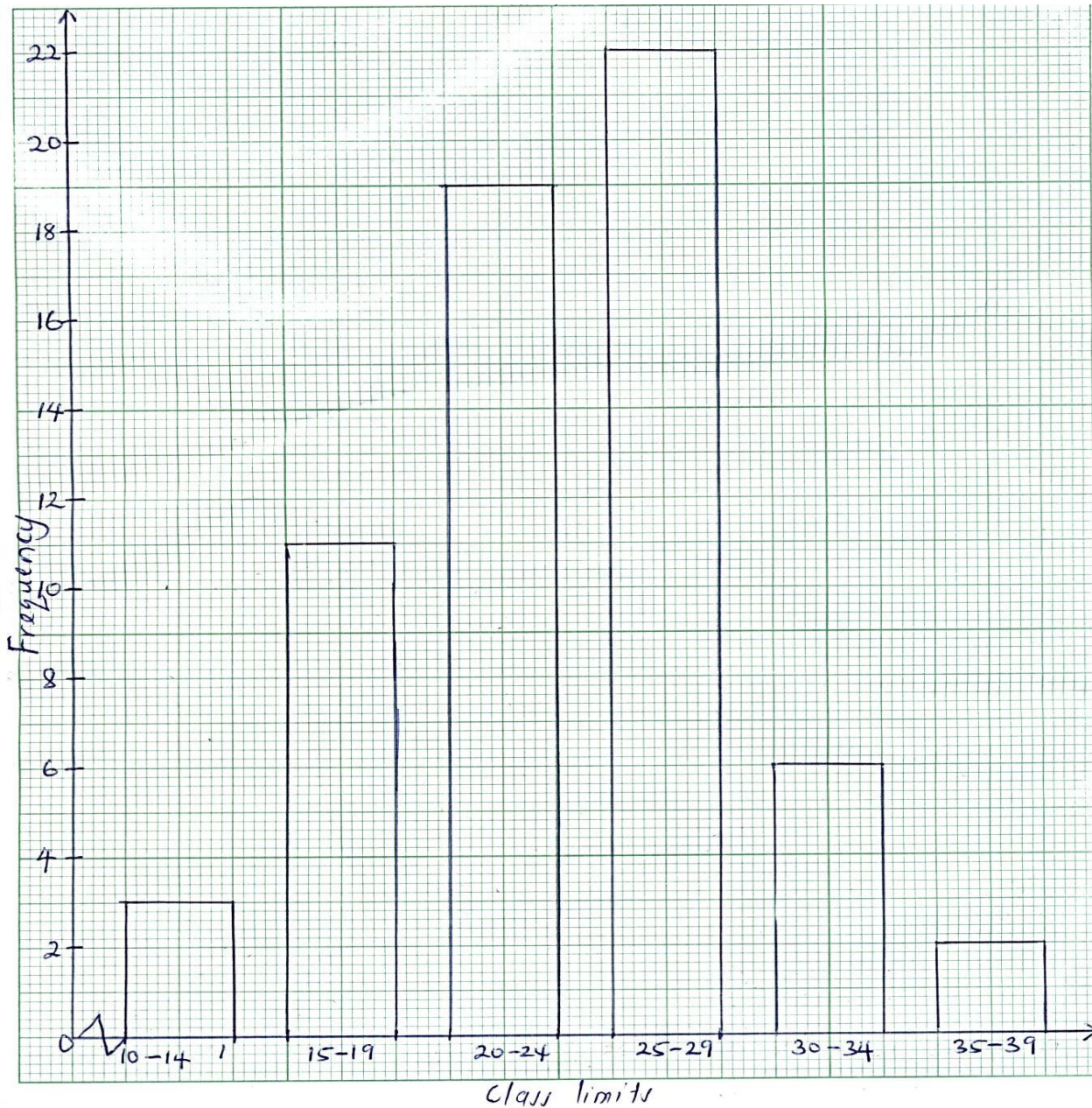

Histogram

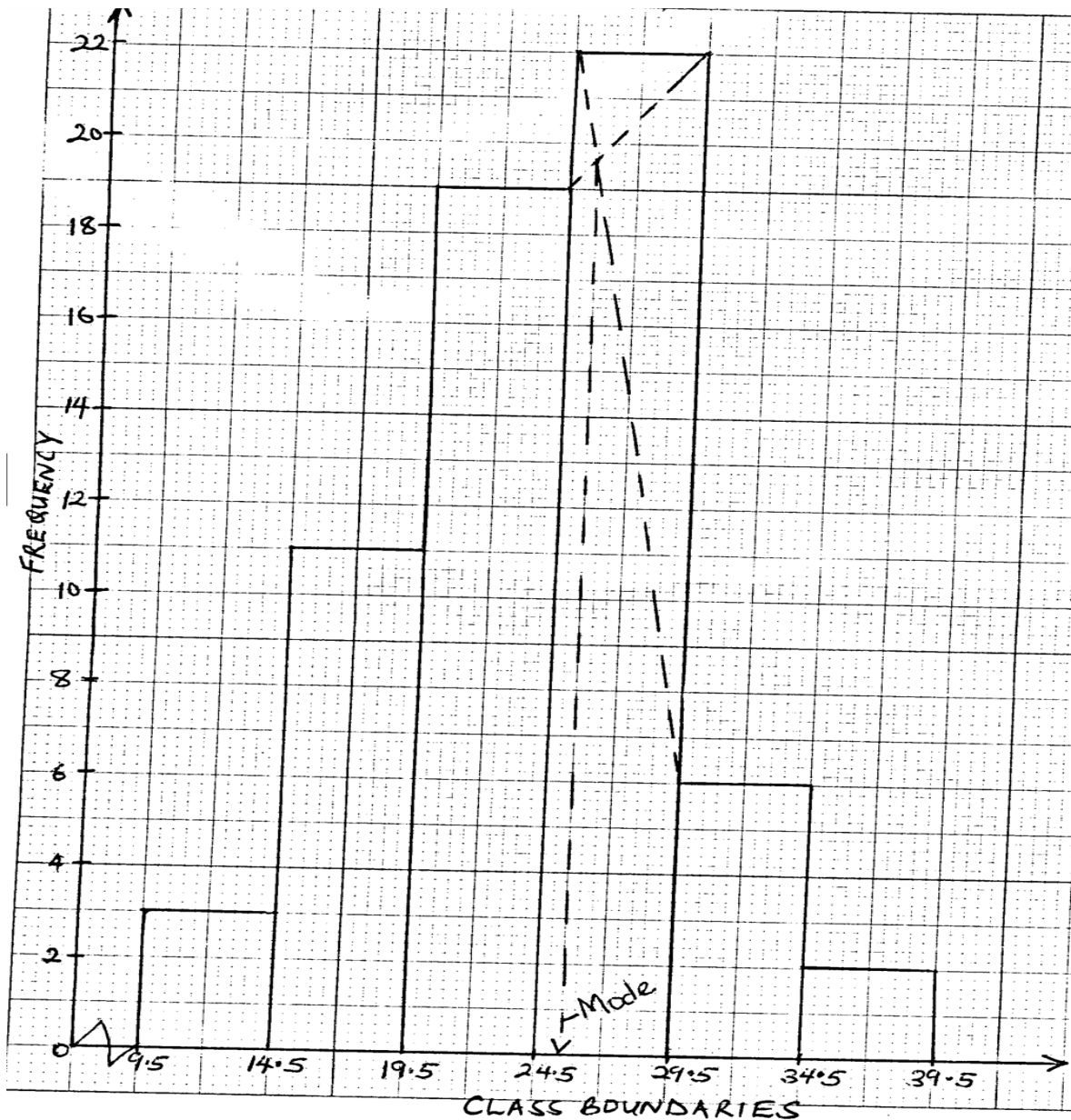

Note: The mode can be estimated from the histogram as shown above.

The reader should also note that these are spaces between the bars for a bar graph while there are no spaces for a histogram.

Example 2

The table below shows the population of Kampala in millions for different age groups

Age group	Population in millions
Below 10	2
10 and under 20	8
20 and under 30	10
30 and under 40	14
40 and under 50	5
50 and under 60	1

Draw a histogram to represent the above data

Solution

Class	Frequency
0-<10	2
10-<20	8
20-<30	10
30-<40	14
40-<50	5
50-<60	1

In this case,

The class boundaries are given i.e. 0-<10

Histogram

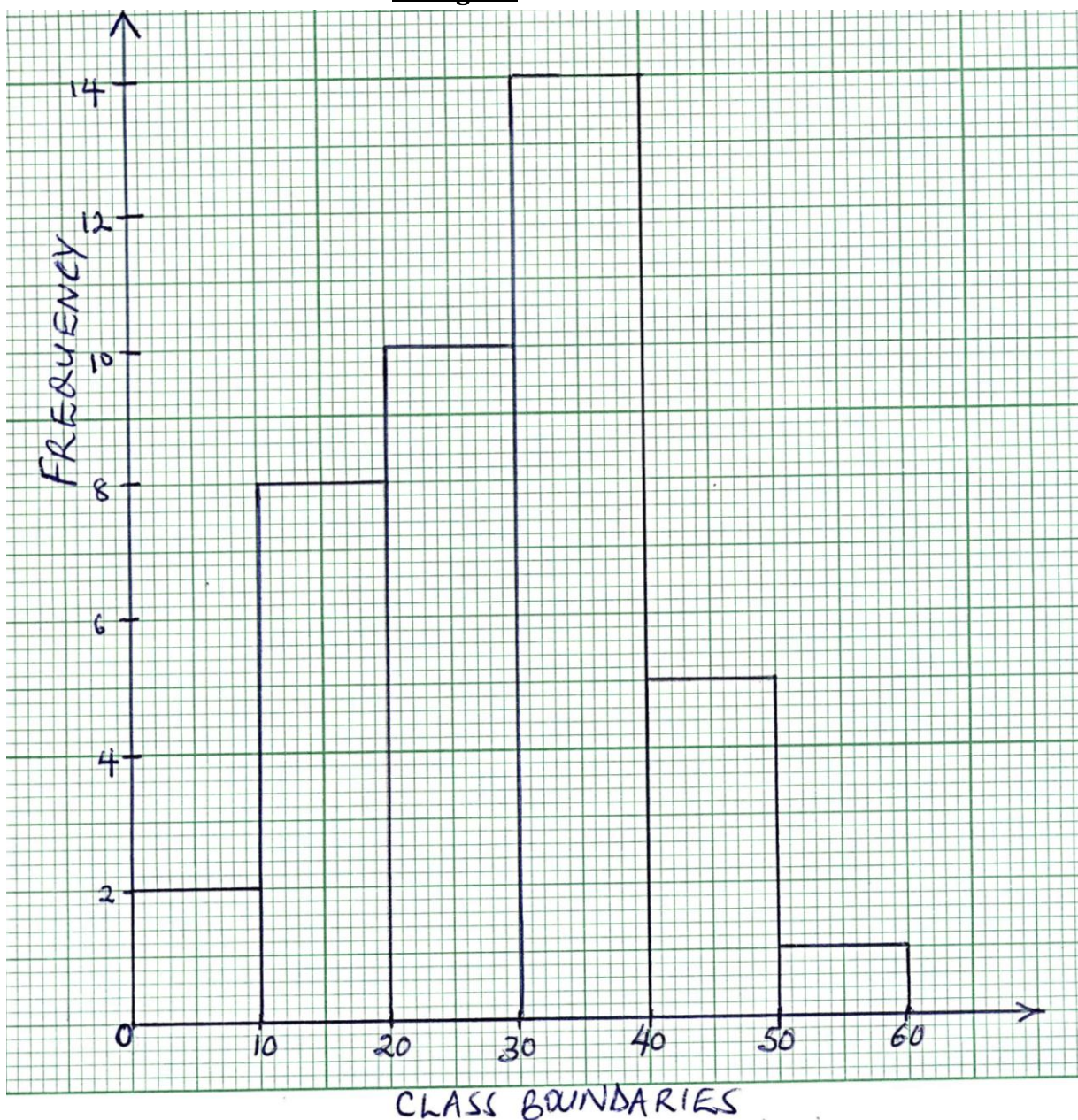

FREQUENCY POLYGON

The frequency polygon is obtained by plotting class frequencies versus class marks. Then the consecutive points are joined using a straight line.

Class mark/ mid interval value $(x) = \frac{1}{2}(\text{Lower class limit} + \text{upper class limit})$

i.e. for the class 10-14, class mark $(x) = \frac{1}{2}(10+14)=12$

The class mark is also known as the mid mark

Example 3

The age distribution of a group of people is given in the table below.

Age(year)	10-19	20-29	30-39	40-49	50-59	60-69	70-79
Frequency	1	3	5	8	12	10	6

Construct a frequency polygon for the data above

Solution

Class Limits	Class mark	Frequency
10-19	14.5	1
20-29	24.5	3
30-39	34.5	5
40-49	44.5	8
50-59	54.5	12
60-69	64.5	10
70-79	74.5	6



MEASURES OF CENTRAL TENDENCY

The measures of central tendency include the mean, mode and median. They are called so because they are centered about the same value.

MEAN

This is the sum of the data values divided by the number of values in the data. It is denoted by \bar{X} .

$$\text{Mean, } \bar{X} = \frac{\sum x}{n} \text{ where } \sum \text{ means summation}$$

The mean can also be calculated from ;

$$(i) \quad \bar{X} = \frac{\sum fx}{\sum f}$$

$$(ii) \quad \bar{X} = A + \frac{\sum fd}{\sum f} \text{ Where } A \text{ is the assumed/working mean and } d = X - A \text{ where } d \text{ is the deviation.}$$

Examples

1. The measured weight for a child over eight year period gave the following results (in kgs); 32, 33, 35, 38, 43, 53, 63, 65. Calculate the mean weight of the child.

$$\begin{aligned} \text{Mean} &= \frac{32+33+35+38+43+53+63+65}{8} \\ &= 45.25\text{kg} \end{aligned}$$

2. The information below gives the age in years of 49 students. Determine the mean age.

Age	14	15	16	17	18	21
Frequency	2	6	14	10	9	8

Solution

Age(x)	Frequency(f)	fx
14	2	28
15	6	90
16	14	224
17	10	170
18	9	162
21	8	168
	$\sum f = 49$	$\sum fx = 842$

$$\bar{X} = \frac{\sum fx}{\sum f} = \frac{842}{49} = 17.184 \text{ years}$$

3. The data below shows the weights in kg of an S.5 class in a certain school.

Weight(kg)	10-14	15-19	20-24	25-29	30-34	35-39	40-44	45-49
Frequency	5	9	12	18	25	15	10	6

Calculate the mean weight of the class

Solution

Class	Class mark(x)	Frequency(f)	fx
10-14	12	5	60
15-19	17	9	153
20-24	22	12	264
25-29	27	18	486
30-34	32	25	800
35-39	37	15	555
40-44	42	10	420
45-49	47	6	282

Mean from assumed mean

The height to the nearest class of 30 pupils is shown in the table below. Using 152cm as the assumed mean, calculate the mean height.

Height, x(cm)	148	149	150	151	152	153	154	155	156
No. of Pupils	1	2	2	3	6	7	4	3	2

Solution

Assumed mean = 152

Height(x)	Frequency(f)	Deviation(d=x-A)	fd
148	1	-4	-4
149	2	-3	-6
150	2	-2	-4
141	3	-1	-3
152	6	0	0
153	7	1	7
154	4	2	8
155	3	3	9
156	2	4	8
	$\sum f = 30$		$\sum fd = 15$

$$\text{Mean, } \bar{X} = A + \frac{\sum fd}{\sum f}$$

$$\bar{X} = 152 + \frac{15}{30} = 152 + 0.5 = 152.5 \text{ cm}$$

4. The number of accidents that took place at black spot on a certain road in 2008 were recorded as follows:

No. of accidents	0-4	5-7	8-10	11-13	14-18
No. of days	2	5	10	8	5

Using 9 as the working mean, calculate the mean no. of accidents per day.

Solution

Class	Mid value(x)	Freq(f)	Deviation(d)	fd
0-4	2	2	-7	-14
5-7	6	5	-3	-15
8-10	9	10	0	0
11-13	12	8	3	24
14-18	16	5	7	35
		$\sum f=30$		$\sum fd=30$

$$\text{Mean, } \bar{X} = A + \frac{\sum fd}{\sum f}$$

$$\bar{X} = 9 + \frac{30}{30} = 10$$

MEDIAN

The median of a group of numbers is the number in the middle when the numbers are in order of magnitude.

Determine the median for the following observations

- (i) 4,1,6,2,6,7,8

Solution

1,2,4,6,6,7,8

The median is 6

- (ii) 3,3,3,7,7,6,7,8

Solution

3, 3, 3, 4, 4, 6, 6, 7, 7

The median = $\frac{4+6}{2} = 5$

The formula below is used to obtain the median for grouped data.

$$\text{Median} = L_1 + \left(\frac{\frac{N}{2} - F_b}{f_m} \right) \times C$$

Where,

L_1 = lower class boundary of the median class

N = Total number of observations

F_b = Cumulative frequency before median class

f_m = Frequency of the median class

C = Class width

Class width is the difference between the lower and upper class boundaries ie for the class 40 – 44, the class width is $44.5 - 39.5 = 5$

Note that it depends on the degree of accuracy ie for the class 7.0 – 7.4, the class width will be $7.45 - 6.95 = 0.5$

Advantages of the median

It is easy to understand and calculate

It is not affected by extreme values

Disadvantage

It is only one or two values to decide the median

THE MODE

This is the number in a set of numbers that occurs the most i.e. the modal value of 5, 6, 3, 4, 5, 2, 5 and 3 is 5 because there are more 5s than any other number.

For grouped data, the mode is calculated from;

$$\text{Mode} = L_1 + \left(\frac{\Delta_1}{\Delta_1 + \Delta_2} \right) \times C$$

Where;

L_1 = lower class boundary of the modal class

Δ_1 = difference between the modal frequency and the value before it

Δ_2 = difference between the modal frequency and the value after it

C = class width

The modal class is identified as the class with the highest frequency and the mode can as well be estimated from the histogram as we have already seen.

Example

The following were the heights of people in a certain town of Uganda.

Height(cm)	101-120	121-130	131-140	141-150	151-160	161-170	171-190
No. of p'ple	1	3	5	7	4	2	1

Calculate the mean, mode, and median for the data.

Solution

Class	Frequency(f)	Class mark(x)	fx	Cf	Class boundaries
101-120	1	110.5	110.5	1	100.5-120.5
121-130	3	125.5	376.5	4	120.5-130.5
131-140	5	135.5	677.5	9	130.5-140.5
141-150	7	145.5	1018.5	16	140.5-150.5
151-160	4	155.5	622	20	150.5-160.5
161-170	2	165.5	331	22	160.5-170.5
171-190	1	180.5	180.5	23	170.5-190.5
Σ	23		3316.5		

$$\text{Mean, } \bar{X} = \frac{\Sigma fx}{\Sigma f} = \frac{3316.5}{23} = 144\text{cm}$$

Median class is 141 - 150

$$\begin{aligned} \text{Median} &= L_1 + \left(\frac{\frac{N}{2} - F_b}{f_m} \right) \times C = 140.5 + \left(\frac{\frac{23}{2} - 9}{7} \right) \times 10 \\ &= 140.5 + 3.57 = 144.1\text{cm} \end{aligned}$$

$$\text{Mode} = L_1 + \left(\frac{\Delta_1}{\Delta_1 + \Delta_2} \right) \times C$$

Modal class is 141 - 150

$$\Delta_1 = 7 - 5 = 2 \quad \text{and} \quad \Delta_2 = 7 - 4 = 3$$

$$\text{Mode} = 140.5 + \left(\frac{2}{2+3} \right) \times 10 = 140.5 + 4 = 144.5\text{cm}$$

Example

Using the data for example 3 (pg. 107), Calculate the mode and median.

Class	Freq(f)	Cf	Class boundaries
10-14	5	5	9.5-14.5
15-19	9	14	14.5-19.5
20-24	12	26	19.5-24.5
25-29	18	44	24.5-29.5
30-34	25	69	29.5-34.5
35-39	15	84	34.5-39.5
40-44	10	94	39.5-44.5
45-49	6	100	44.5-49.5

$$\text{Median} = L_1 + \left(\frac{\frac{N}{2} - F_b}{f_m} \right) \times C$$

Median class is 30 - 34

$$\text{Median} = 29.5 + \left(\frac{\frac{100}{2} - 44}{25} \right) \times 5 = 29.5 + 1.2 = 30.7 \text{ kg}$$

$$\text{Mode} = L_1 + \left(\frac{\Delta_1}{\Delta_1 + \Delta_2} \right) \times C$$

Modal class is 30 - 34, $\Delta_1 = 25 - 18 = 7$ and $\Delta_2 = 25 - 15 = 10$

$$\text{Mode} = 29.5 + \left(\frac{7}{7+10} \right) \times 5 = 29.5 + 2.06 = 31.56 \text{ kg}$$

THE OGIVE

The Ogive is also known as the cumulative frequency curve where by cumulative frequency curve is plotted against the upper class boundaries and the consecutive points are joined into a smooth curve using free hand.

Example

The frequency distribution table shows the weights of 100 children measured to the nearest kg.

Weight	10-14	15-19	20-24	25-29	30-34	35-39	40-44	45-39
No. of Children	5	9	12	18	25	15	10	6

Draw a cumulative frequency curve for the data.

Solution

Class	Freq(f)	Cf	Class boundary
10-14	5	5	9.5-14.5
15-19	9	14	14.5-19.5
20-24	12	26	19.5-24.5
25-29	18	44	24.5-29.5
30-34	25	69	29.5-34.5
35-39	15	84	34.5-39.5
40-44	10	94	39.5-44.5
45-49	6	100	44.5-49.5

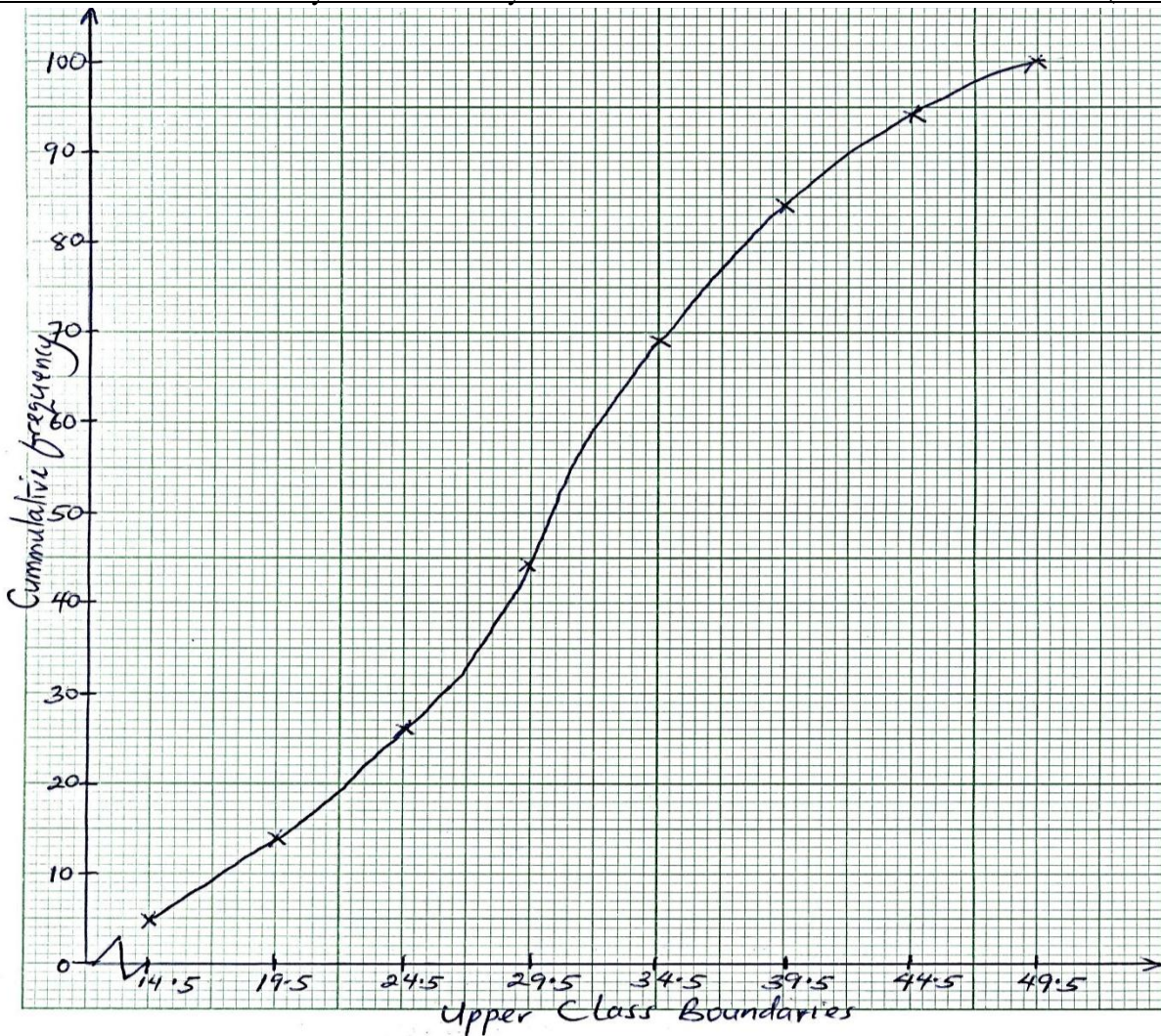

Estimating the median and quartiles using the Ogive.

The marks obtained by 40 pupils in a mathematics examination were as follows:

Marks	20-29	30-39	40-49	50-59	60-69	70-79
No. of pupils	2	4	8	15	9	2

Plot a cumulative frequency curve and use it to estimate the median mark, upper quartile, lower quartile and the inter quartile range

Solution

Class	Freq(f)	Cf	Upper class boundaries
20-29	2	2	29.5
30-39	4	6	39.5
40-49	8	14	49.5
50-59	15	29	59.5
60-69	9	38	69.5
70-79	2	40	79.5

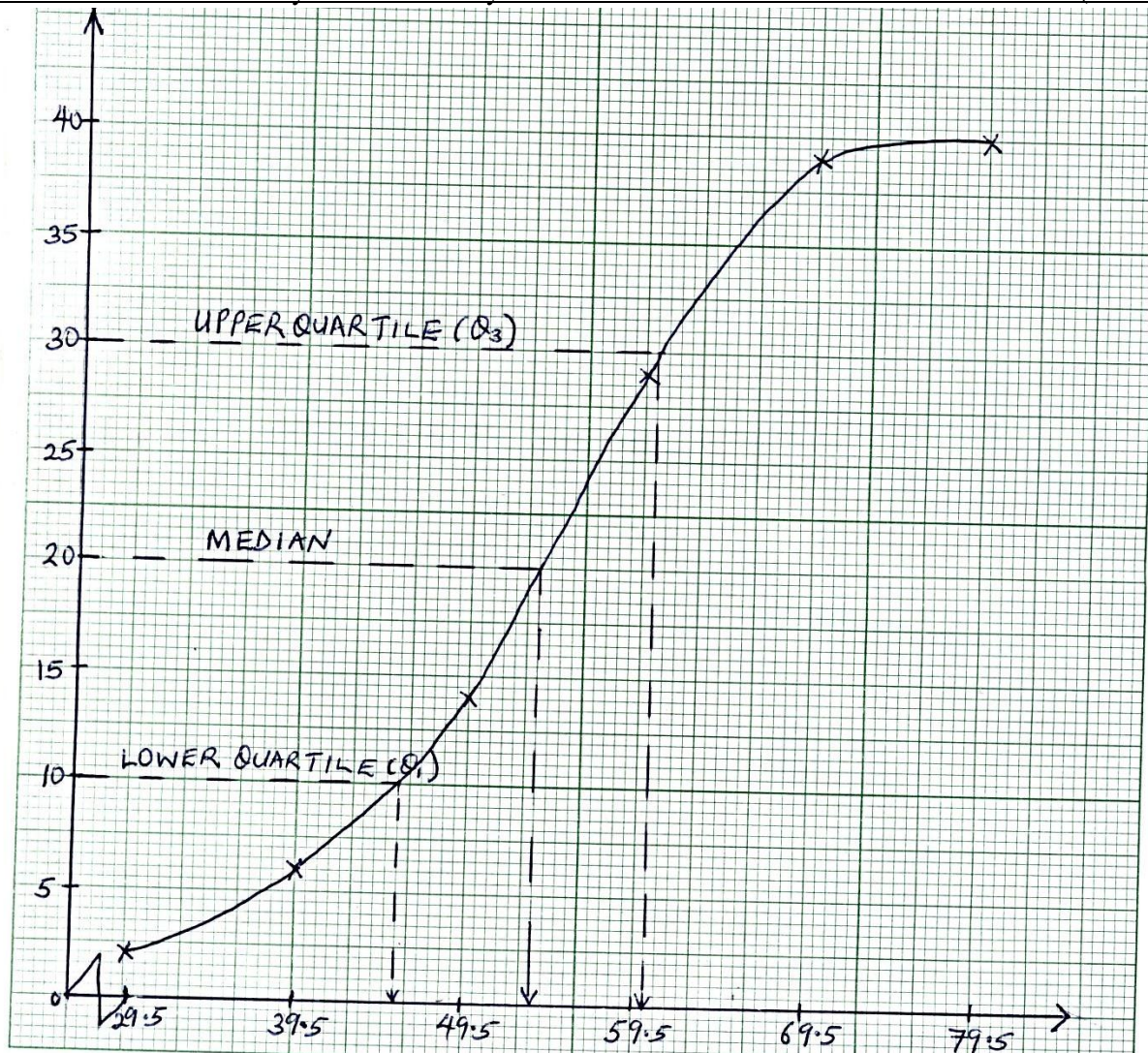

Upper class boundaries

$$\text{Median} = \left(\frac{1}{2}N\right)^{\text{th}} = 20^{\text{th}} \text{ measure}$$

Draw a dotted line across the graph from Cf = 20 to meet the curve and drop a vertical dotted line to meet the horizontal axis. This gives the estimated median

Hence the median = 54 marks.

Quartiles

The quartiles divide a distribution into four equal parts.

The lower quartile (Q_1) is the value 25% way through the distribution and the value 75% way through the distribution is called the upper quartile (Q_3).

$$\text{Lower quartile } (Q_1) = \left(\frac{1}{4}N\right)^{\text{th}} \text{ measure} = 45.5$$

$$\text{Upper quartile, } (Q_3) = \left(\frac{3}{4}N\right)^{\text{th}} \text{ measure} = 60$$

The difference between the upper quartile and lower quartile is called the Interquartile range. The Interquartile range = $Q_3 - Q_1 = 60 - 45.5 = 14.5$

$$\text{The semi interquartile range or quartile deviation} = \frac{1}{2}(Q_3 - Q_1) = 7.25$$

Percentiles

The percentiles divide a distribution into one hundred equal parts.

The lower quartile, Q_1 is the 25th percentile P_{25} , the median is the 50th percentile P_{50} and the upper quartile Q_3 is the 75th percentile P_{75} .

Example

The data shows the marks obtained by 80 form IV pupils in a school. Draw a cumulative frequency and use your graph to find the 20th and 80th percentile mark.

Mark	1-10	11-20	21-30	31-40	41-50	51-60	61-70	71-80	81-90	91-100
Freq	3	5	5	9	11	15	14	8	6	4

Solution

Marks	Freq	C.f	Upper class boundaries
1-10	3	3	10.5
11-20	5	8	20.5
21-30	5	13	30.5
31-40	9	22	40.5
41-50	11	33	50.5
51-60	15	48	60.5
61-70	14	62	70.5
71-80	8	70	80.5
81-90	6	76	90.5
91-100	4	80	100.5

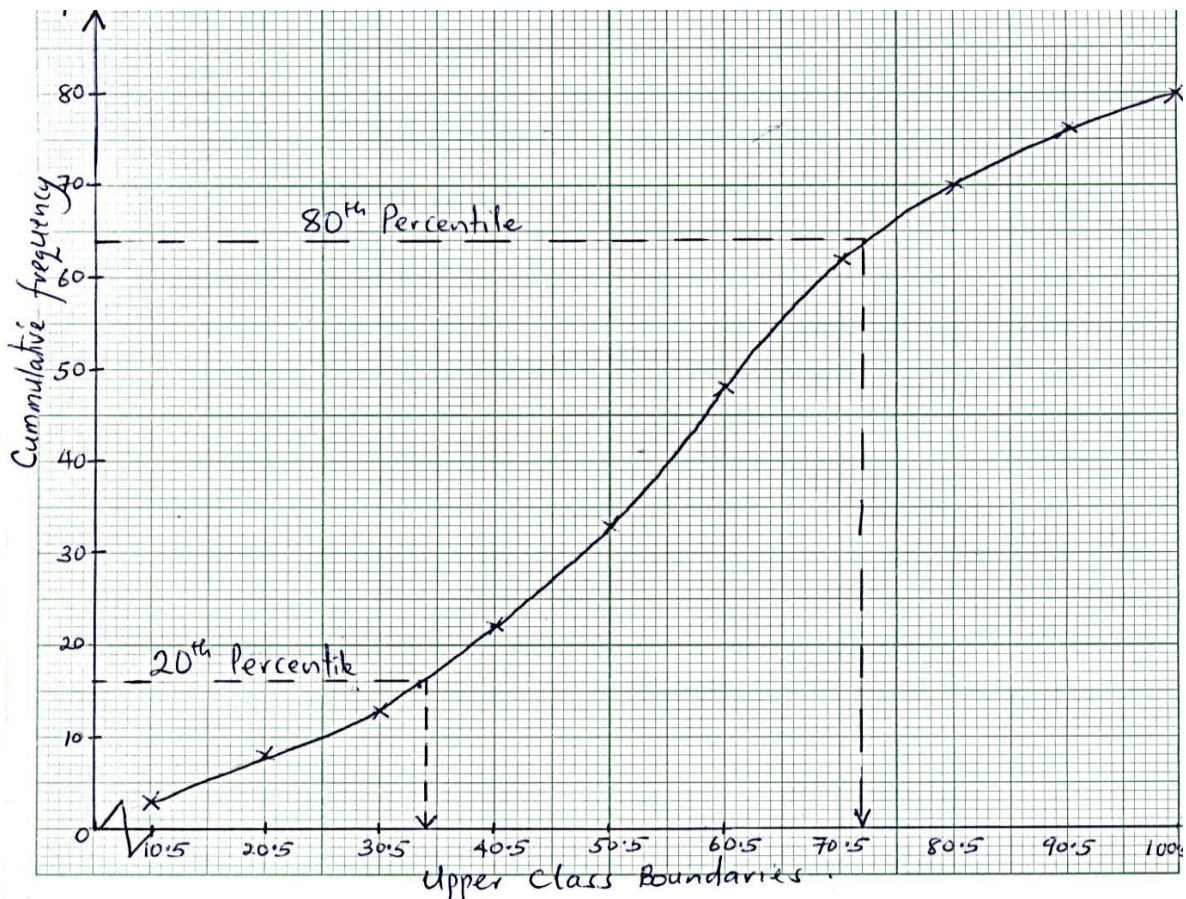

$$20^{\text{th}} \text{ percentile mark} = \left(\frac{20}{100} \times 80\right)^{\text{th}} \text{ mark} = 32.5$$

$$80^{\text{th}} \text{ percentile mark} = \left(\frac{80}{100} \times 80\right)^{\text{th}} \text{ mark} = 71.5$$

Measures of dispersion

The spread of observations in relation to a measure of central tendency of the given data is known as dispersion. In order to compare data, the measure of dispersion is taken into account along with the measure of central tendency.

The range

This is the difference between the largest and the smallest values of the data.

i.e. for the data about lengths of leaves in garden tree, 5,6,7,7,4,5,3,2,9,8,8,6,5,3

$$\text{Range} = 9 - 2 = 7$$

Standard deviation:

This is the positive square root of variance. It is denoted by σ

$$\text{Standard deviation } (\sigma) = \sqrt{\text{Variance}}$$

The following expressions can be used to calculate the standard deviation;

$$\sigma = \sqrt{\frac{\sum fx^2}{\sum f} - \left(\frac{\sum fx}{\sum f}\right)^2}$$

When using the assumed mean A,

$$\sigma = \sqrt{\frac{\sum fd^2}{\sum f} - \left(\frac{\sum fd}{\sum f}\right)^2}$$

Note: the expression under the root is the variance

Examples

1. Calculate the standard deviation for the distribution of marks in the table below.

Marks	5	6	7	8	9
Frequency	3	8	9	6	4

Solution

Marks(x)	Frequency(f)	fx	fx ²
5	3	15	75
6	8	48	288
7	9	63	441
8	6	48	384
9	4	36	324
Σ	30	210	1512

$$\sigma = \sqrt{\frac{\sum fx^2}{\sum f} - \left(\frac{\sum fx}{\sum f}\right)^2}$$

$$\sigma = \sqrt{\frac{1512}{30} - \left(\frac{210}{30}\right)^2} = \sqrt{50.4 - 49} = \sqrt{1.4} = 1.183 \text{ marks}$$

2. The table below shows the weights to the nearest kg of 150 patients who visited a certain health unit during a certain week.

Weight(kg)	10-19	20-29	30-39	40-49	50-59	60-69	70-79
No. of patients	30	16	24	32	28	12	8

Calculate the standard deviation of the weights of the patients.

Class	Freq(f)	x	fx	fx ²
10-19	30	14.5	435	6307.5
20-29	16	24.5	392	9604
30-39	24	34.5	828	28566
40-49	32	44.5	1424	63368
50-59	28	54.5	1526	83167
60-69	12	64.5	774	49923
70-79	8	74.5	596	44402
	$\Sigma f = 150$		$\Sigma fx = 5975$	$\Sigma fx^2 = 285337.5$

$$\text{Standard deviation, } \sigma = \sqrt{\frac{\Sigma fx^2}{\Sigma f} - \left(\frac{\Sigma fx}{\Sigma f}\right)^2}$$

$$\sigma = \sqrt{\frac{285337.5}{150} - \left(\frac{5975}{150}\right)^2}$$

$$= \sqrt{315.56} = 17.76$$

3. The table below gives the points scored by a team in various events. Find the mean and standard deviation using working mean $A=4$

Points	0	1	2	3	4	5	6	7
No. of events	1	3	4	7	5	5	2	3

Solution

Points	Frequency	d = x - A	fd	fd ²
0	1	-4	-4	16
1	3	-3	-9	27
2	4	-2	-8	16
3	7	-1	-7	7
4	5	0	0	0
5	5	1	5	5
6	2	2	4	8
7	3	3	9	27
Σ	30		-10	100

$$\text{Mean, } \bar{X} = A + \frac{\Sigma fd}{\Sigma f} = 4 + \frac{-10}{30} = 3.67 \text{ points}$$

$$\text{Standard deviation, } \sigma = \sqrt{\frac{\Sigma fd^2}{\Sigma f} - \left(\frac{\Sigma fd}{\Sigma f}\right)^2}$$

$$= \sqrt{\frac{106}{30} - \left(\frac{-10}{30}\right)^2} = \sqrt{3.533 - 0.111} = 1.85 \text{ points}$$

4. The table below shows the weight in kg of 100 boys in a certain school

Weight(kg)	60-62	63-65	66-68	69-71	72-74
Frequency	8	10	45	30	7

Using the assumed mean of 67, calculate the mean and standard deviation

Solution

Weight	Freq(f)	Mid value (x)	D	fd	fd ²
60-62	8	61	-6	-48	288
63-65	10	64	-3	-30	90
66-68	45	67	0	0	0
69-71	30	70	3	3	270
72-74	7	73	6	6	252
	$\Sigma f=100$			$\Sigma fd=54$	$\Sigma fd^2=900$

$$\text{Mean, } \bar{X} = A + \frac{\Sigma fd}{\Sigma f} = 67 + \frac{54}{100} = 67.54 \text{ kg}$$

$$\begin{aligned} \text{Standard deviation, } \sigma &= \sqrt{\frac{\Sigma fd^2}{\Sigma f} - \left(\frac{\Sigma fd}{\Sigma f}\right)^2} \\ &= \sqrt{\frac{900}{100} - \left(\frac{54}{100}\right)^2} = 2.951 \end{aligned}$$

Trial questions

1. The table below shows the weekly wages of a number of workers at a small factory.

Weekly wages	75-84	85-94	95-104	105-114	115-124	125-134	135-144	145-154
Frequency	2	3	7	11	10	8	4	1

Calculate the modal, median and the mean wage.

2. Below are heights, measured to the nearest cm of 50 pupils

157 167 165 162 160 157 160 152 157 162
 157 165 152 162 155 160 157 160 162 160
 157 152 167 157 160 160 162 165 157 160
 157 157 157 160 157 162 155 157 160 157
 150 162 152 160 157 157 165 160 162 150

- a) Make a frequency distribution table by dividing them into class intervals of 5 starting with the class 148-152
- b) Draw a cumulative frequency curve and use it to estimate
 (i) The median (ii) Interquartile range

3. The table below shows marks obtained by students of mathematics in a certain school.

Marks	30-<40	40-<50	50-<60	60-<70	70-<80
No. of students	2	15	10	11	27

- (i) Calculate the mean, median and standard deviation for the above data
 (ii) Draw an Ogive for the above data

4. Below are heights, measured to the nearest cm of 50 pupils.

157 167 165 162 160 157 160 152 157 162
 157 165 152 162 155 160 157 160 162 160
 157 152 167 157 160 160 162 165 157 160
 157 157 157 160 157 162 155 157 160 157
 150 162 152 160 157 157 165 160 162 150

- a) Make a frequency distribution table by dividing them into class intervals of 5 starting with the class 148-152
 b) Draw a cumulative frequency curve and use it to estimate
 (i) The median (ii) Interquartile range

5. The table below shows marks obtained by students of mathematics in a certain school

Marks	30-<40	40-<50	50-<60	60-<70	70-<80
No. of students	2	15	10	11	27

- (i) Calculate the mean, median and standard deviation for the above data
 (ii) Draw an Ogive for the above data

6. Sixty pupils were asked to draw a free hand line of length 20cm. The lengths of the lines were measured to nearest cm, and were recorded as shown in the table.

Length(cm)	11-13	13-15	15-17	17-19	19-21	21-23	23-25
Frequency	3	6	11	15	13	10	2

- a) Calculate the mean length
 b) Draw a cumulative frequency graph and estimate the median, the upper and the lower quartiles.

7. Below are the heights to the nearest cm of 40 students

150 170 152 155 169 167 157 158 157
 167 164 165 164 163 162 163 158 158
 160 160 159 161 161 161 160 160 160
 159 162 160 159 160 161 161 156 150

- a) Make a frequency distribution table starting with class interval 150-152
 b) Draw an Ogive and use it to estimate the median, Interquartile range and the 20th percentile height.
 8. Calculate the mean and the standard deviation of the following distribution of scores

Scores	1-5	6-10	11-15	16-20	21-25	26-30	31-35
Frequency	3	19	38	69	45	21	5

9. The numbers of the eggs collected from a poultry farm for 40 consecutive days were as follows.

138 145 145 157 150 142 154 140
 146 135 128 149 164 147 152 138
 168 142 135 125 158 135 148 176
 146 150 165 144 126 153 136 163
 161 156 144 132 176 140 147 130

a) Construct a frequency distribution table with classes of equal interval width 5, starting from 125-129.

b) Draw a cumulative frequency curve (Ogive) and use it to estimate the

(i) Median

(ii) Interquartile range

(iii) Median number of eggs

10. The following marks were obtained by 85 students in an English examination;

96 81 23 62 44 18 62 70 72 40 81 70 30 28 23 02
 60 20 48 50 19 33 32 58 71 62 19 12 83 53 81 73
 52 25 71 61 46 64 35 59 82 82 42 63 43 17 35 72
 37 54 47 76 18 44 65 45 70 38 63 89 31 37 93 03
 63 25 52 53 38 57 53 71 70 63 89 31 37 93 58 58

a) Using class intervals of 10 marks, and starting with a class of 0-9, construct a frequency distribution table.

b) Using your table to find the (i) Median mark

(ii) Mean mark

(iii) Standard deviation

11. The marks obtained by 50 students in a test were:

76 17 57 63 12 96 38 46 82 48
 61 93 44 19 70 60 71 18 40 54
 50 27 62 42 63 52 53 38 62 25
 62 23 32 81 31 63 64 18 70 27
 52 81 35 63 38 37 44 19 70 32

a) Construct a grouped frequency distribution table with equal class intervals of 10 marks, starting with the 10 – 19 class group.

b) Draw a histogram and use it to estimate the modal mark.

c) Calculate the mean and standard deviation of the mark.

12. The times taken by a group of students to solve a mathematical problem are given below.

Time(min)	5-9	10-14	15-19	20-24	25-29	30-34
No. of students	5	14	30	17	11	3

- Draw a histogram for the data. Use it to estimate the modal time for solving a problem.
- Calculate the mean time and standard deviation of solving a problem.

13. The table below shows the weights (in kg) of 150 patients who visited a certain health unit during a certain week.

Weight (kg)	0-19	20-29	30-39	40-49	50-59	60-69	70-79
No. of patients	30	16	24	32	28	12	8

- Calculate the appropriate mean and modal weights of the patients.
- Plot an Ogive for the above data. Use the Ogive to estimate the median and semi interquartile for the weights of patients.

14. In agricultural experiment, the gains in mass (in kg) of 100 cows during a certain period were recorded as follows;

Gain in mass (kgs)	5 - 9	10-14	15-19	20-24	25-29	30-34
Frequency	2	29	37	16	14	2

- Calculate the (i) mean mass gained
(ii) Standard deviation
(iii) Median

15. The information below shows the marks of 36 candidates in oral examination.

30 31 55 49 56 47
 36 41 39 45 39 50
 42 43 44 39 46 56
 30 48 53 38 50 63
 40 54 61 46 56 44
 53 60 56 50 62 52

- Construct a frequency distribution table having an interval of 6 marks starting with the 30-35 class group.
- Draw a cumulative frequency curve and use it to estimate the median mark.
- Calculate the mean mark.

16. Construct a frequency distribution of the following data on the length 5 of time (in minutes), it took 50 persons to complete a certain application form.

29 22 38 28 34 32 23 19 21 31
 16 28 19 18 12 27 15 21 25 16
 30 17 22 29 18 29 25 20 16 11
 17 12 15 24 25 21 22 17 18 15
 21 20 23 18 17 15 16 26 23 22

Using class intervals of length 5 minutes starting with the interval 10-14. Calculate the (i) Mean
(ii) Standard deviation using ; Assumed mean $A = 22$

17. The ages of students in an Institution were as follows.

Age	18-<19	19-<20	20-<21	21-<22	23-<24	24-<25
No. of students	12	35	38	24	8	3

- (i) Draw a histogram of the data and use it to estimate the modal age.
- (ii) Use the data to estimate the median, upper and lower quartile ages.
- (iii) Calculate the interquartile and semi interquartile range

18. Estimate the lower and upper quartiles for the following frequency distribution using an Ogive.

Class	0-9	10-19	20-29	30-39	40-49
Frequency	2	14	24	12	8

CHAPTER 12: INDEX NUMBERS

An index number is a statistical measure, which represents the change in a variable or group of variables with respect to time, environment or other characteristics.

Base year

This is the year against which all the other years are compared. The price in the base year is normally denoted as P_0

Current year

This is the year (period) for which the index is to be calculated. The price in the current year is normally denoted by P_1

SIMPLE INDEX NUMBER

A simple index measures the relative change from the base period for a single measurement. This includes price index, quantity index etc. Simple price index is often known as a price relative and it is given by

$$\text{Simple index number} = \frac{\text{price in current year}}{\text{price in the base year}} \times 100 = \frac{P_1}{P_0} \times 100$$

Basic characteristics of index numbers

- The index for the base period is 100, which is standard practice. The statement “2012=100” is used to identify the base
- The change in the value of the index from the base period to any given period is simply a measure of percentage change from the base period for two periods
- The change in the value of an index does not indicate percentage change unless one time period is the base period

Example 1

An article cost shs 500 in 1990 and shs 800 in 1994. Taking 1990 as the base year, find the price relative in 1994.

Solution

$$\text{Price relative} = \frac{P_1}{P_0} \times 100 = \frac{800}{500} \times 100 = 160$$

This indicates that the price of the article has gone up by 60%

Example 2

The wage of nurses in Uganda in 1995 was shs 20,000. The wage of the same nurses in 1997 was increased by 25,000/=. Using 1995 as the base year, calculate the nurses' wage index for 1997.

Solution

$$W_1 = 20,000 + 25,000 = 45,000$$

$$W_0 = 20,000$$

$$\text{Wage index} = \frac{W_1}{W_0} \times 100 = \frac{45000}{20000} \times 100 = 225$$

Therefore the nurses wage increased by 125% in 1995

Note: The percentile wage is always omitted in the final answer.

Simple price index

The simple price index is obtained from the average of the price relatives which is the arithmetic mean of the price relatives (simple indices) for a group of items

$$\text{S.P.I} = \frac{\sum \frac{P_1}{P_0}}{n} \times 100$$

Simple aggregate price index

This is the total price of a group of items in a given period divided by the total price in the base period multiplied by 100.

$$\text{S.A.P.I} = \frac{\text{sum of prices in current year}}{\text{sum of prices in base year}} \times 100 = \frac{\sum P_1}{\sum P_0} \times 100$$

Example 1

The table shows the price in pounds of maize and beans in 1999 and 2004

Item	1999	2004
Maize(bag)	80	120
Beans(bag)	10	15

Determine the simple aggregate price index for the total cost of one bag of maize and beans.

Solution

$$\text{Total cost of items in 1999} = 80 + 10 = 90$$

$$\text{Total cost of items in 2004} = 120 + 15 = 135$$

$$\text{Simple aggregate price index} = \frac{\sum P_1}{\sum P_0} \times 100 = \frac{135}{90} \times 100 = 150$$

Example 2

Data chip manufactures and sells three computer chip models; the basic, financial and scientific. The respective retail prices are 950, 3500 and 7000 in 1994; 150, 1800 and 2500 in 1998; 80, 600 and 1250 in 2002. Calculate the simple aggregate price index for 1998 and 2002 taking 1994 as the base year.

Solution

Chip model	Retail price		
	1994	1998	2002
Basic	950	150	80
Financial	3500	1800	600
Scientific	7000	2500	1930
Σ	11450	4450	1930

$$\text{S.A.P.I for 1998} = \frac{4450}{11450} \times 100 = 38.86$$

$$\text{S.A.P.I for 2002} = \frac{1930}{11450} \times 100 = 16.86$$

Conclusion:

Since the index in the base period, 1994, is 100, the difference in the indices for 1994 and 1998 indicates that the average price of the three models declined by;

$$100 - 38.86 = 61.14\%$$

The decline in price from 1994 to 2002 is 83.14%

Weighted price index

Index numbers are at times needed where there is more than just one item i.e. and index number that compares the cost of living depends on food, housing, entertainment, etc. They can be calculated in terms of the weight by obtaining the weighted price index which is given by;

$$\text{W.P.I} = \frac{\sum WI}{\sum W} \text{ where I is the price index}$$

$$\text{Or W.P.I} = \frac{\sum \frac{P_1}{P_0} W}{\sum W} \times 100$$

Note: the weighted price index can also be referred to as the weighted aggregate price index

Example

Find the cost of living based on the following data.

Item	Price Index	Weight
Food	120	172
Clothing	124	160
Housing	125	170
Transport	135	210
Others	104	140

Solution

Item	Price Index (I)	Weight(W)	WI
Food	120	172	20640
Clothing	124	160	19840
Housing	125	170	21250
Transport	135	210	28350
Others	104	140	14560
Total		852	104640

$$\text{Cost of living index} = \text{W.P.I} = \frac{\sum WI}{\sum W} = \frac{104640}{852} = 122.82$$

Composite index

Composite index measures relative change from the base period for a group of closely related items.

Example

The following items are used in the assembly of TV set; 8 transistors, 22 resistors, 9 capacitors, 2 diodes and a circuit board. Due to inflation of the price of each component has increased as shown below.

Item	Transistors	Resistors	Capacitors	Diodes	Circuit
1980	(Shs) 120	165	150	160	200
1988	(Shs) 180	210	170	180	250

Calculate the composite index number of the assembled TV set in 1988 using 1980 as the base year.

Solution

Item	Weight (w)	Price(P ₀)	WP ₀	Price(P ₁)	WP ₁
Transistor	8	120	960	180	1440
Resistor	22	165	3630	210	4620
Capacity	9	150	1350	170	1530
Diode	2	160	320	180	360
Circuit	1	200	200	250	250
Total			6460		8200

$$\text{Composite Index} = \frac{8200}{6460} \times 100 = 127$$

Weighted aggregate price index

The weighted price is obtained if the weights or quantities of the various commodities are given. It is given by

W.A.P.I = $\frac{\sum WP_1}{\sum WP_0} \times 100$ or W.A.P.I = $\frac{\sum P_1 Q_1}{\sum P_0 Q_0} \times 100$ where Q and W represents quantity and weights respectively.

Examples.

The prices of unit values of four commodities A, B, C, and D in the years 1994 and 1996 were as below

Commodities	1994	1996	Weights
	Price	Price	
A	400	500	7
B	900	1100	2
C	600	700	3
D	600	800	6

- a) Taking 1994 as the base year, Calculate the
- Simple price Index for 1996
 - Weight average price Index
- b) Suppose that the actual quantities consumed per week by a family in 1994 were 5kg, 2kg, 3litres and $1\frac{1}{2}$ kg of A, B, C, and D respectively. Determine the average percentage price increase of the commodities in 1996.

Solution

(a)

Commodity	Weight	Price(P ₀)	Price (P ₁)	$\frac{P_1}{P_0}$	$\frac{P_1}{P_0} \times W$
A	7	400	500	1.25	8.75
B	2	900	1100	1.22	2.44
C	3	600	700	1.17	3.50
D	6	600	800	1.33	8
Total	18			4.97	22.69

(i) Simple price index = $\frac{\sum \frac{P_1}{P_0}}{n} \times 100 = \frac{4.97}{4} \times 100 = 124.25$

$$(ii) \text{ Weight average price index} = \frac{\sum \frac{P_1}{P_0} W}{\sum W} \times 100 = \frac{22.69}{18} \times 100 = 126.1$$

(b)

Commodity	Weight	Price(P ₀)	P ₀ W	Price (P ₁)	P ₁ W
A	5	400	2000	500	2500
B	2	900	1800	1100	2200
C	3	600	1800	700	2100
D	1.5	600	900	800	1200
Total			6500		8000

$$\text{W.A.P.I} = \frac{\sum WP_1}{\sum WP_0} \times 100 = \frac{8000}{6500} \times 100 = 123.1$$

Percentage increase in earnings or income = W.A.P.I - 100

Example

Nsambya Hillside High school bought three types of chicken feeds in 1998 and 2000. The weights of the corresponding price (Shs) are given in the table below. Using 1998 as the base year, calculate the weighted average price index.

Commodity	Weight	Price 1998	Price 2000
A	120	500	600
B	60	300	360
C	50	250	400

Solution

Commodity	Weight	Price (P ₀)	Price (P ₁)	$\frac{P_1}{P_0}$	$\frac{P_1}{P_0} \times W$
A	120	500	600	1.2	144
B	60	300	360	1.2	72
C	50	250	400	1.6	80
Total	230				296

$$\text{Index} = \frac{296}{230} \times 100 = 128.7$$

Conclusion: The commodities increased by 28.7%

Example

An average family in Kampala spent the following amounts on the items shown in the years 1997 and 1998.

	1997	1998
ITEM	Amount (Shs)	Amount (Shs)
Housing	80,000	90,000
Clothing	20,000	20,000
Electricity	20,000	25,000
Water	25,000	25,000
Food	140,000	160,000
Transport	30,000	36,000
Medical	30,000	35,000
Miscellaneous	30,000	40,000

Using 1997 as the base year, calculate the simple aggregate expenditure index for 1998.

Solution

$$\begin{aligned} \text{Total expenditure in 1997} &= 80,000 + 20,000 + 20,000 + 25,000 + 140,000 + 30,000 + 30,000 \\ &= 345,000/= \end{aligned}$$

$$\begin{aligned} \text{Total expenditure in 1998} \\ &= 90,000 + 20,000 + 25,000 + 25,000 + 160,000 + 36,000 + 35,000 + 40,000 = 431,000/= \end{aligned}$$

$$\begin{aligned} \text{Simple aggregate Expenditure Index} &= \frac{431,000}{345,000} \times 100 \\ &= 124.9 \end{aligned}$$

Example

The table below shows the average retail price in shillings of a kilogram of Sugar during the years 1983 – 1988

Year	1983	1984	1985	1986	1987	1988
Retail Price	110	120	130	150	165	185

- (i) Using 1983 as the base, find the price index corresponding to all the years. By how much would a family have reduced their consumption of sugar in 1988 if they had to spend the same amount of sugar as they did in 1983?
- (ii) Using 1986 as the base, find the retail price index of the given years
- (iii) Using 1983 – 1985 as the base, find the retail price in 1989, if the price index was 160.

Solution

(i)

Year	Retail price	Price index $\left(\frac{P_1}{P_0} \times 100\right)$
1983	110	100
1984	120	109.09
1985	130	118.18
1986	150	136.36
1987	165	150
1988	185	168.18

$$\text{Price index in 1988} = \frac{68.18}{100} \times 1 = 0.6818$$

$$\text{Reduction in consumption} = 1 - 0.6818 = 0.3182\text{kg}$$

(ii) Base value (P_0) = 150

Year	Retail price	Price index $\left(\frac{P_1}{P_0} \times 100\right)$
1983	110	73.33
1984	120	80
1985	130	86.78
1986	150	100
1987	165	110
1988	185	123.33

$$(iii) \text{ Average retail price} = \frac{110+120+130}{3} = 120$$

$$\frac{P_{1999}}{120} \times 100 = 160$$

$$P_{1999} = 192$$

Example

The cost of making a cake is calculated from the cost of baking flour, sugar, milk and eggs. The table below gives the cost of these items in 1990 and 1996

Item	1990	1996	Weight
Flour per Kg	600	780	12
Sugar per Kg	500	400	5
Milk per litre	250	300	2
Eggs per egg	100	150	1

Using 1990 as the base year;

(i) Calculate the price relative for each item. Hence find the simple price index for the cost of making a cake.

(ii) Find the weighted aggregate price index for the cost of a cake.

Item	1990(P_0)	1996(P_1)	Weight	$\frac{P_1}{P_0}$	P_0W	P_1W
Flour /kg	600	780	12	1.3	7200	9360
Sugar /kg	500	400	5	0.8	2500	2000
Milk /Ltr	250	300	2	1.2	500	600
Eggs / egg	100	150	1	1.5	100	150
						12110
Σ			20	4.8	10300	12110

The price relatives are represented by $\frac{P_1}{P_0}$ in the table

$$\text{Simple Price Index} = \frac{4.8}{4} \times 100 = 120$$

$$\text{Weighted aggregate price index} = \frac{12110}{10300} \times 100 = 117$$

Example

the table below represents the changes in domestic consumption of the indicated food items

Commodity	Unit	Price in shillings		Quantity	
		2009	2010	2009	2010
A(Matooke)	kg	180	150	1500	2500
B(Bread)	Unit	500	700	80	100
C(Milk)	Litre	400	700	60	60
D(Vegetables)	Kg	1000	800	45	60
E(Fruit)	Kg	700	600	120	100

using 2009 as the base year, calculate the

- Price index for each food item for 2010
- Simple aggregate price index for 2010
- Weighted aggregate price index for 2010

Solution

$$(i) \quad P.I_A = \frac{150}{180} \times 100 = 83.33$$

$$P.I_B = \frac{700}{500} \times 100 = 140$$

$$P.I_C = \frac{700}{400} \times 100 = 175$$

$$P.I_D = \frac{800}{1000} \times 100 = 80$$

$$P.I_E = \frac{600}{700} \times 100 = 85.7143$$

Item	P ₀	P ₁	Q ₀	Q ₁	P ₀ Q ₀	P ₁ Q ₁
A	180	150	1500	2500	270000	375000
B	500	700	80	100	40000	70000
C	400	700	60	60	24000	42000
D	1000	800	45	60	45000	48000
E	700	600	120	100	84000	60000
Σ	2780	2950			463000	595000

$$(ii) \quad S.A.P.I = \frac{\text{sum of prices in current year}}{\text{sum of prices in base year}} \times 100 = \frac{\sum P_1}{\sum P_0} \times 100$$

$$= \frac{2950}{2780} \times 100 = 106.2$$

$$(iii) \quad W.A.P.I = \frac{\sum P_1 Q_1}{\sum P_0 Q_0} \times 100 = \frac{595000}{463000} \times 100 = 128.51$$

Trial questions

1. The average price for bananas, milk and meat were as follows for 1997 and 1998

ITEM	PRICES	
	1997	1998
Bananas	Shs 3000 per bunch	Shs 5000 per bunch
Milk	Shs 700 per Litre	Shs 800 per Litre
Meat	Shs 2500 per Kg	Shs 2000 per kg

- a) Calculate the price relatives for these commodities for 1998 taking 1997 as the base year
- b) Given that meat, bananas and milk are given weights of 2, 1, and 3 respectively taking 1997 as the base year, calculate the index number for the total costs of the commodities for a family in 1998.
2. The table below shows the prices in pounds sterling per metric tons of four metals on two dates of 1997

Metal	25 th April	10 th Nov
Copper	100	959
Tin	7390	7550
Lead	540	576
Nickel	2045	2600

- (i) Taking 25th April as the base date, calculate the price indices for 10th Nov 1997. Comment on the price of each metal.
- (ii) Taking copper as the base metal, calculate the price indices for the other metals for the two dates given.

- (iii) Calculate the price per metric tons of bronze on 25th April (Bronze is a mixture of copper (92%) and tin (8%))

3. The cost of making a cake is calculated from the cost of baking flour, sugar, milk and eggs. The following table gives the cost of these items in 1985 and 1986.

Item	1985	1986	Weight
Flour per Kg	60	78	12
Sugar per kg	50	40	5
Milk per litre	25	30	2
Egg per Egg	10	15	1

Using 1985 as the base year,

- Calculate the price for each item hence find the simple price index of making a cake.
 - Find the weighted aggregated price index for the cost of the cake.
 - If the unit of making a cake in 1986 was shs 30, find the cost in 1985 using the two indices in (i) and (ii)
4. The table below shows the prices and quantities of some four commodities A, B, C and D for the years 2006 and 2007

Item	Price per unit		Quantities	
	2006	2007	2006	2007
A	100	120	36	42
B	110	100	96	88
C	50	65	10	12
D	80	85	11	10

Using 2006 as the base year, Calculate

- Price index number for 2007
- Simple aggregate price number for 2007 (Ans:108.824)
- Weighted aggregate price index number (Ans:123.071)

5. The table below represents the weight and index for five items

Item	Food	Tobacco	Housing	Transport	Medical
Weight	304	129	331	120	116
Index	124	126	127	119	128

Determine the weighted index number for all items (Ans: 125.115)

CHAPTER 13: MOVING AVERAGES

Many sets of data display trends, which depend upon time of year or the particular month or even the time of the day etc.

For example, we would expect that sales of umbrellas would peak during winter months and then tail off during the summer months etc.

In fact, if we were to plot a graph showing sales of umbrellas against the seasons of the year (autumn, winter, etc.) We would expect some wildly fluctuating graph as follows.

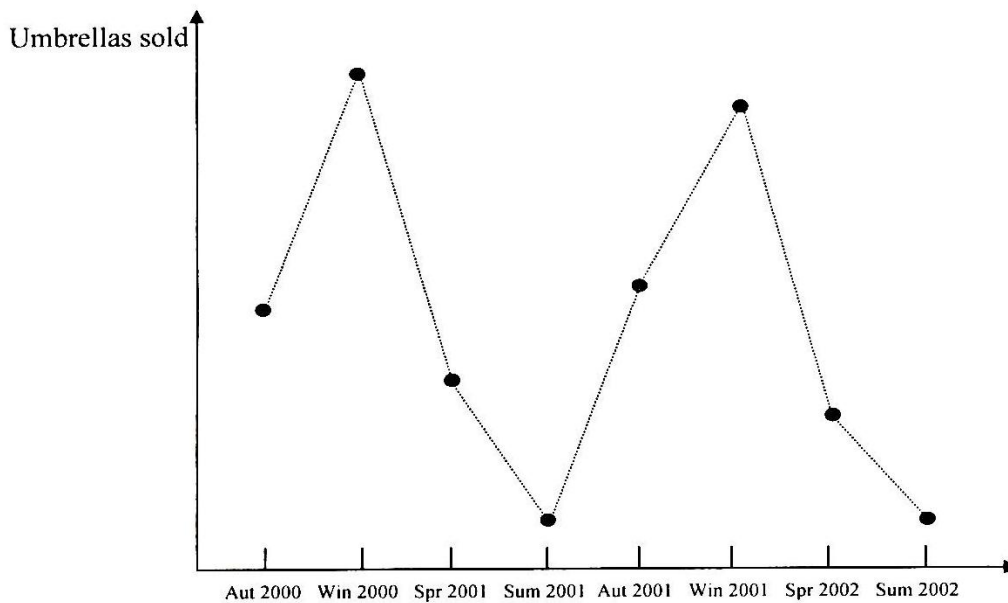

This is called a **time series graph**

In attempting to glean meaningful information from such graphs, we really need to isolate the different seasons, each of which exerts its own seasonal influence.

One way of doing this is to use what are termed moving averages, which are designed to level out the large fluctuations which can occur in a set of data that varies over time.

Example 1

Suppose you have measured the weight of a child over an eight period and have the following figures (in kg) 32, 33, 35, 38, 43, 53, 63, 65.

We could take the average of each 3 years period. These are 3 year moving averages

$$\text{The first is } \frac{32+33+35}{3} = 33.3$$

$$\text{The second is } \frac{33+35+38}{3} = 35.3$$

$$\text{The third is } \frac{35+38+43}{3} = 38.7$$

$$\text{The fourth is } \frac{38+43+53}{3} = 44.7$$

$$\text{The fifth is } \frac{43+53+63}{3} = 53.0$$

The sixth is $\frac{53+63+65}{3} = 60.3$ (this is the last)

If we are to calculate the 4 year moving average,

The first is $\frac{30+33+35+38}{4} = 34$

The second is $\frac{33+35+38+43}{4} = 37.3$

The third is $\frac{35+38+43+53}{4} = 42.3$

The fourth is $\frac{38+43+53+63}{4} = 49.3$

The fifth is $\frac{43+53+63+65}{4} = 56$ (this is the last)

Example 2

A college records the number of people who sign up for adult education classes each term. The table shows the numbers from autumn 2000 to summer 2002.

Term	Autumn 2000	Spring 2001	Summer 2001	Autumn 2001	Spring 2002	Summer 2002
No. of people	520	300	380	640	540	500

- Calculate the three point moving average for these data.
- Plot the three point moving averages with the original data together on the same axis.
- Use the trend to estimate the three point moving average that would be plotted at summer 2002

Solution

a) 1st three point moving average = $\frac{520+300+380}{3} = 400$

$$2^{\text{nd}} = \frac{300+380+640}{3} = 440$$

$$3^{\text{rd}} = \frac{380+640+540}{3} = 520$$

$$4^{\text{th}} = \frac{640+540+500}{3} = 560$$

- b) We always plot moving average in the middle of the respective grouping.

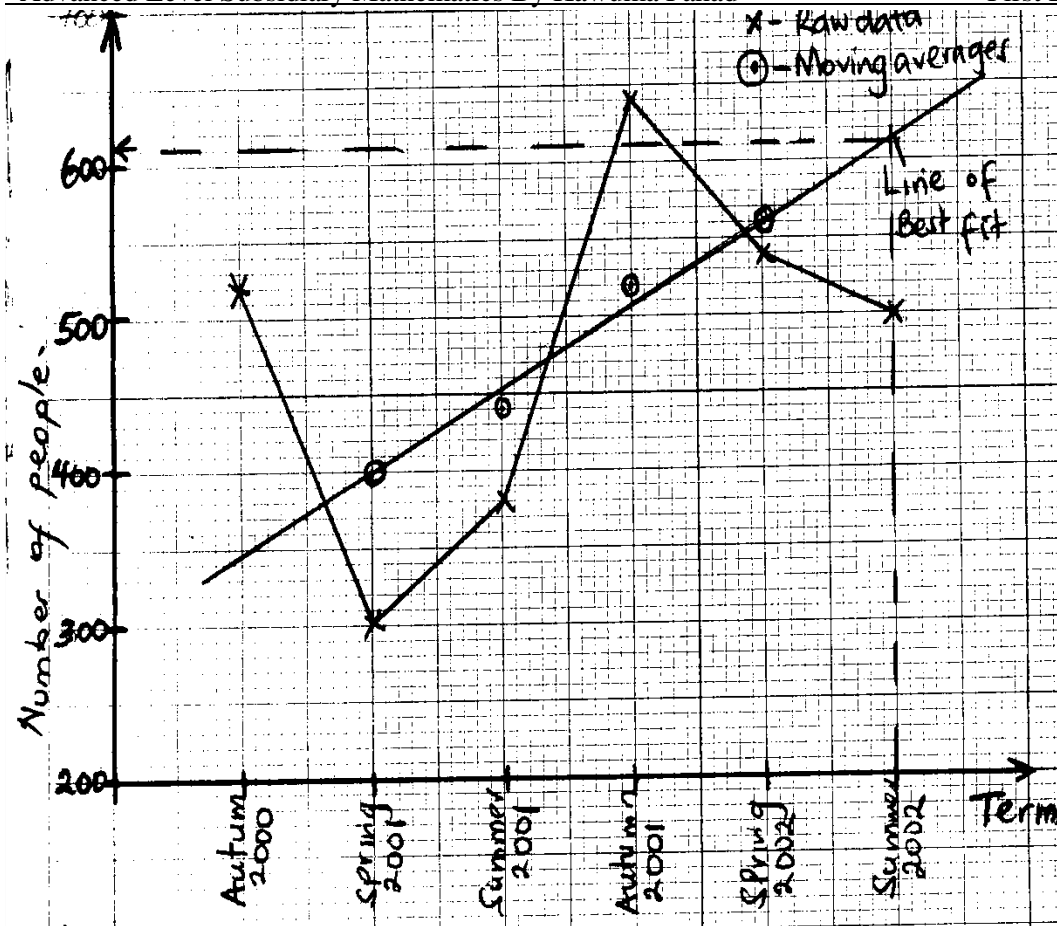

c) By plotting the line of best fit, we estimate the next moving average to be 610.

Note: The line of best fit will give us the trend

Example3

The table below shows the amounts of Jenny’s gas bills from September 2001 to December in dollars.

Date	September 2001	December 2001	March 2002	June 2002	September 2002	December 2002
Amount of bill	28.70	32.40	29.10	7.80	30.30	38.60

Calculate the four point moving averages for these data
Graph the raw data and the moving averages.

Solution

$$1^{st} \text{ value} = \frac{28.70+32.40+29.10+7.80}{4} = 24.5$$

$$2^{nd} \text{ value} = \frac{32.40+29.10+7.80+30.30}{4} = 24.9$$

$$3^{rd} \text{ value} = \frac{29.10+7.80+30.30+38.90}{4} = 26.45$$

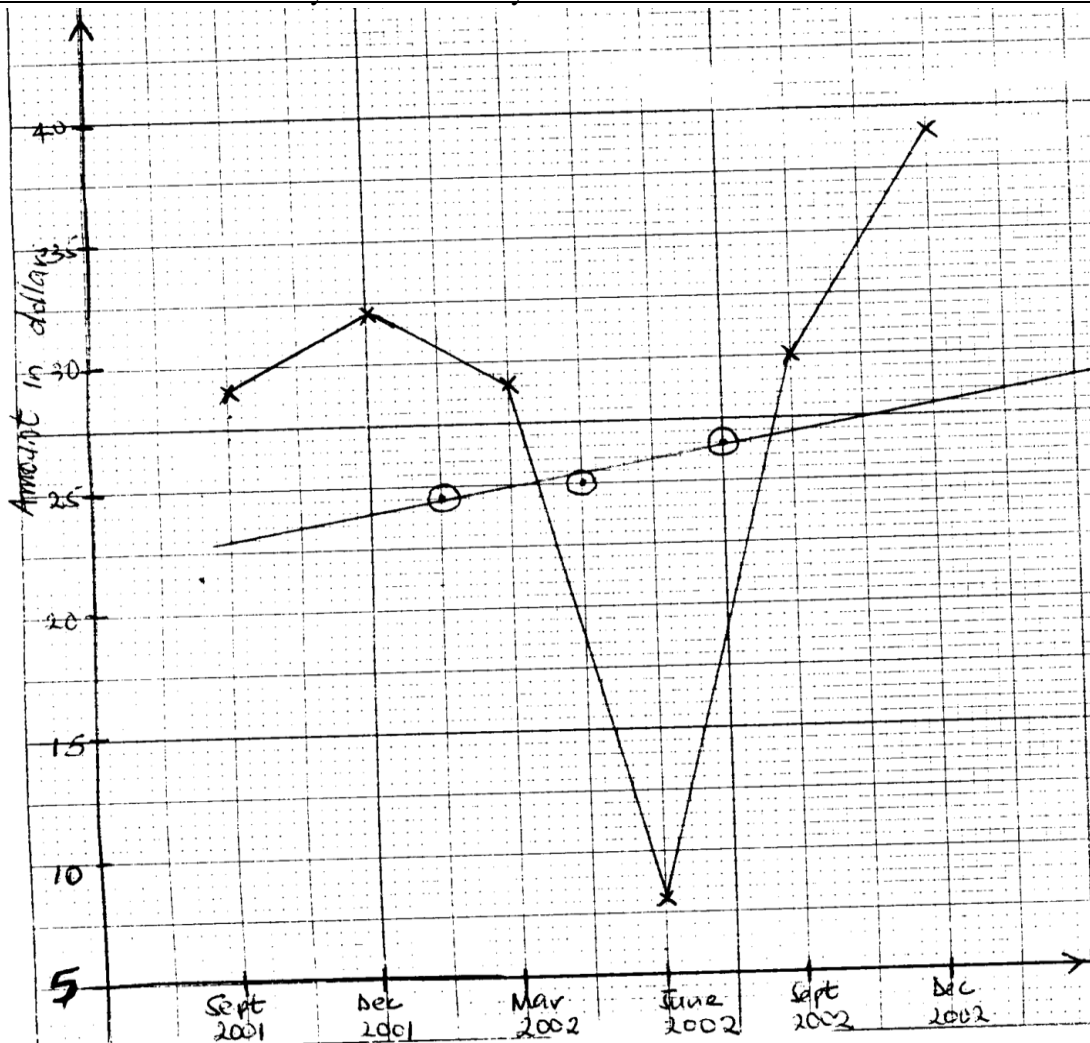

Example 4

The amount of water used every after 6 months over a period of 4 years is shown in the table below

Year	2008		2009		2010		2011	
Month	Mar	Oct	Mar	Oct	Mar	Oct	Mar	Oct
Water used (m ³)	36	45	29	43	38	45	52	46

Calculate the three point moving averages for these data

Graph the raw data and the moving averages hence comment on the amount of water used in the period.

Solution

$$1^{st} \text{ value} = \frac{36+45+29}{3} = 36.7$$

$$2^{nd} \text{ value} = \frac{45+29+43}{3} = 39$$

$$3^{rd} \text{ value} = \frac{29+43+38}{3} = 36.7$$

$$4^{\text{th}} \text{ value} = \frac{43+38+45}{3} = 42$$

$$5^{\text{th}} \text{ value} = \frac{38+45+52}{3} = 45$$

$$6^{\text{th}} \text{ value} = \frac{45+52+46}{3} = 47.7$$

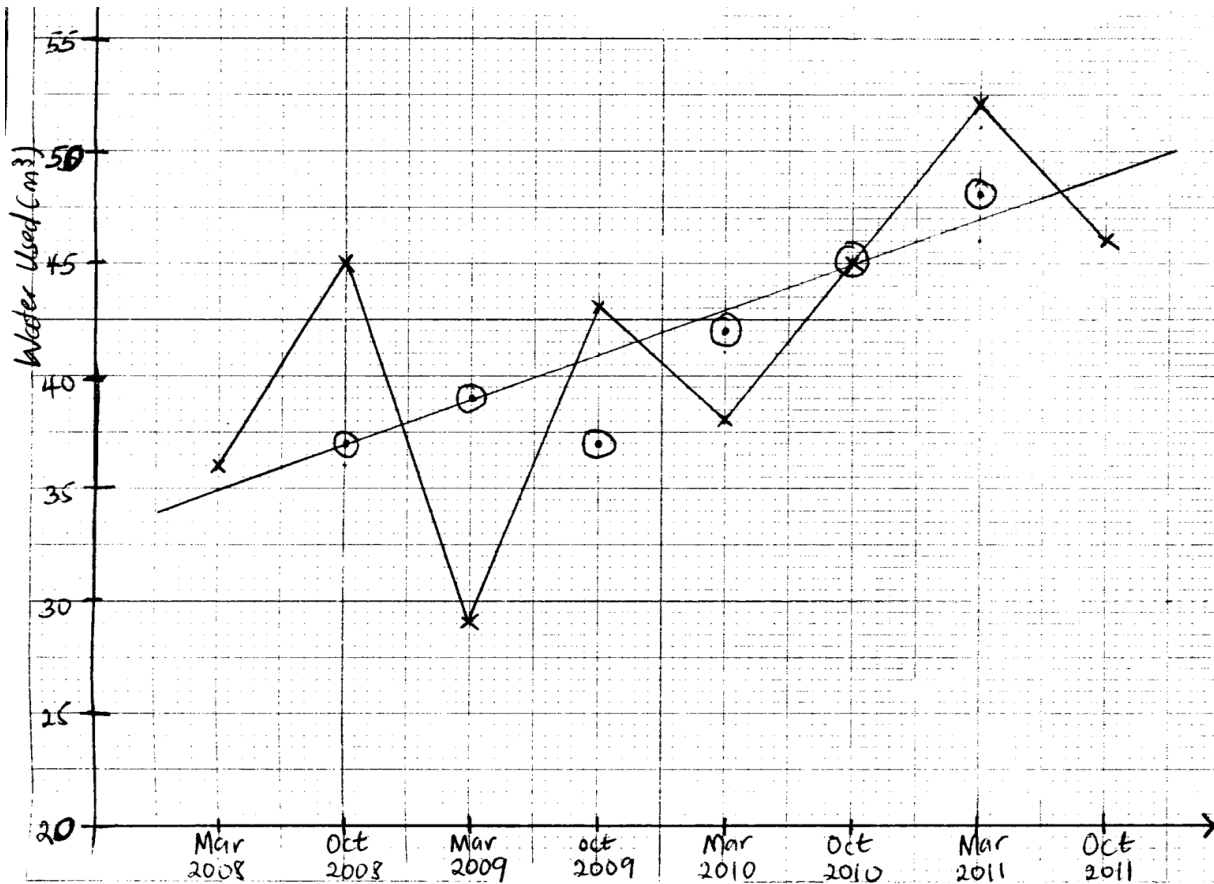

Example 5

The table below shows the annual production of copper in millions of kilograms in a certain country for the period 1960 – 1970

Year	1960	'61	'62	'63	'64	'65	'66	'67	'68	'69	1970
Annual production	196	146	172	178	155	152	130	154	166	164	135

- a) Construct a 5 year moving average. Graph the moving averages together with the original data
- b) Comment on the trend of production over the 11 year period.

Solution

(a) 1st value = $\frac{196+146+172+178+155}{5} = 169.4$

2nd value = $\frac{146+172+178+155+152}{5} = 160.6$

3rd value = $\frac{172+178+155+152+130}{5} = 157.4$

4th value = $\frac{178+155+152+130+154}{5} = 153.8$

$$5^{\text{th}} \text{ value} = \frac{155+152+130+154+166}{5} = 151.4$$

$$6^{\text{th}} \text{ value} = \frac{152+130+154+166+164}{5} = 153.2$$

$$7^{\text{th}} \text{ value} = \frac{130+154+166+164+135}{5} = 149.8$$

You can summarize these values in a table as shown below

Year	1960	'61	'62	'63	'64	'65	'66	'67	'68	'69	1970
Prodn	196	146	172	178	155	152	130	154	166	164	135
Av	X	X	169.4	160.6	157.4	153.8	151.4	153.2	149.8	X	X

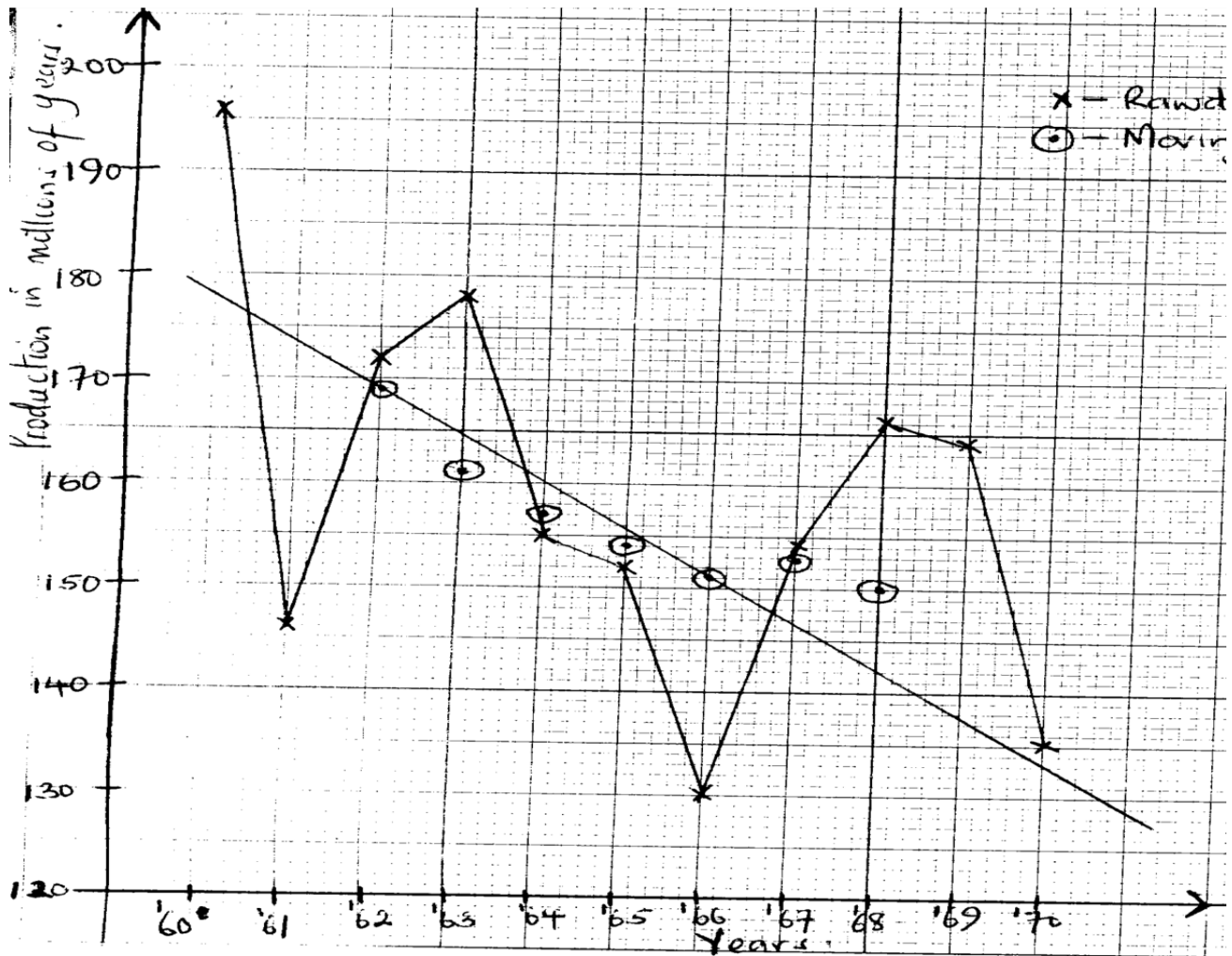

b). The production over the 11 year period generally decreases

Example 6

The table below shows the amount of milk (in thousands of litres) produced by a certain exotic farm in yearly quarters for the 1986 – 1989 period.

Year	QUARTER			
	1 st	2 nd	3 rd	4 th
1986	19.5	30.0	32.5	25.0
1987	30.5	37.0	38.5	26.5
1988	36.5	44.5	46.6	35.0
1989	45.5	50.5	52.5	42.5

- (i) Calculate the four point moving averages for the data.
(ii) On the same axes, plot the four point moving averages for the data.
(iii) Comment on the trend of milk production over the period of 4 years.

Solution

(i)

$$1^{\text{st}} = \frac{19.5+30.0+32.5+25.0}{4} = 26.75$$

$$2^{\text{nd}} = \frac{30.0+32.5+25.0+30.5}{4} = 29.5$$

$$3^{\text{rd}} = \frac{32.5+25.0+30.5+37.0}{4} = 31.25$$

$$4^{\text{th}} = \frac{25.0+30.5+37.0+38.5}{4} = 32.75$$

$$5^{\text{th}} = \frac{30.5+37.0+38.5+26.5}{4} = 33.125$$

$$6^{\text{th}} = \frac{37.0+38.5+26.5+36.5}{4} = 34.625$$

$$7^{\text{th}} = \frac{38.5+26.5+36.5+44.5}{4} = 36.5$$

$$8^{\text{th}} = \frac{26.5+36.5+44.5+46.5}{4} = 38.5$$

$$9^{\text{th}} = \frac{36.5+44.5+46.5+35.0}{4} = 40.625$$

$$10^{\text{th}} = \frac{44.5+46.5+35.0+45.5}{4} = 42.875$$

$$11^{\text{th}} = \frac{46.5+35.0+45.5+50.0}{4} = 44.25$$

$$12^{\text{th}} = \frac{35.0+45.5+50.0+52.5}{4} = 45.75$$

$$13^{\text{th}} = \frac{45.5+50.0+52.5+42.5}{4} = 47.625$$

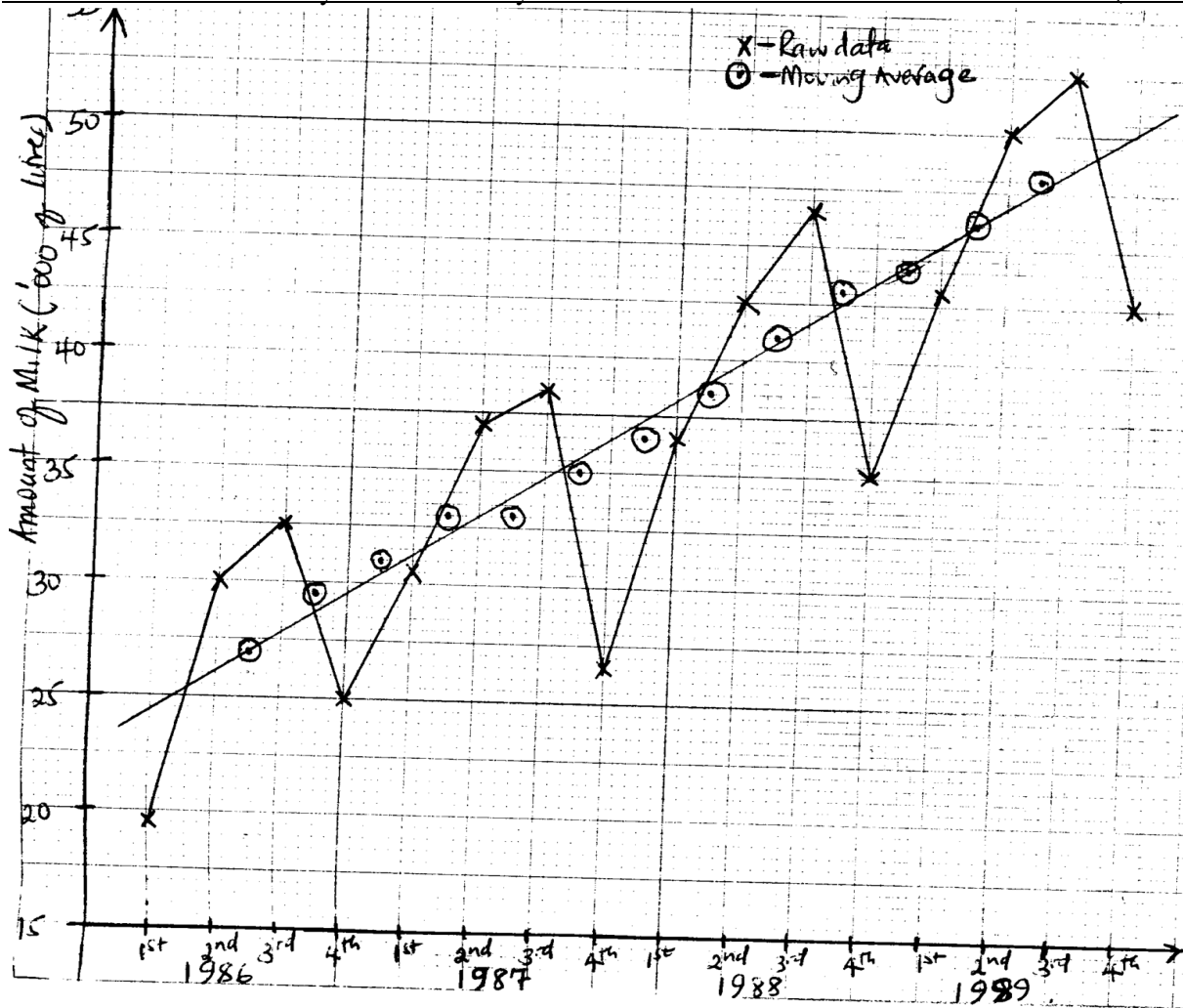

(iii) The production generally increases over the given period

Example 7

The table below indicates the quarterly variation in a certain school earnings in millions of shillings 1950 - 1952.

Year	1st	2nd	3rd	4th
1950	11.0	10.0	10.0	9.4
1951	10.5	9.7	9.4	9.3
1952	9.9	9.3	9.0	8.6

- (i) Calculate the quarterly moving averages for the data
- (ii) On the same axes, plot the four point moving averages and the raw data
- (iii) Comment on the trend of the school earnings

Solution

(i)

$$1^{st} = \frac{11.0+10.0+10.0+9.4}{4} = 10.1$$

$$2^{nd} = \frac{10.0+10.0+9.4+10.5}{4} = 9.975$$

$$3^{rd} = \frac{10.0+9.4+10.5+9.7}{4} = 9.9$$

$$4^{th} = \frac{9.4+10.5+9.7+9.4}{4} = 9.75$$

$$5^{th} = \frac{10.5+9.7+9.4+9.3}{4} = 9.575$$

$$6^{\text{th}} = \frac{9.7+9.4+9.3+9.9}{4} = 9.575$$

$$7^{\text{th}} = \frac{9.4+9.3+9.9+9.3}{4} = 9.475$$

$$8^{\text{th}} = \frac{9.3+9.9+9.3+9.0}{4} = 9.375$$

$$9^{\text{th}} = \frac{9.9+9.3+9.0+8.6}{4} = 9.2$$

(ii)

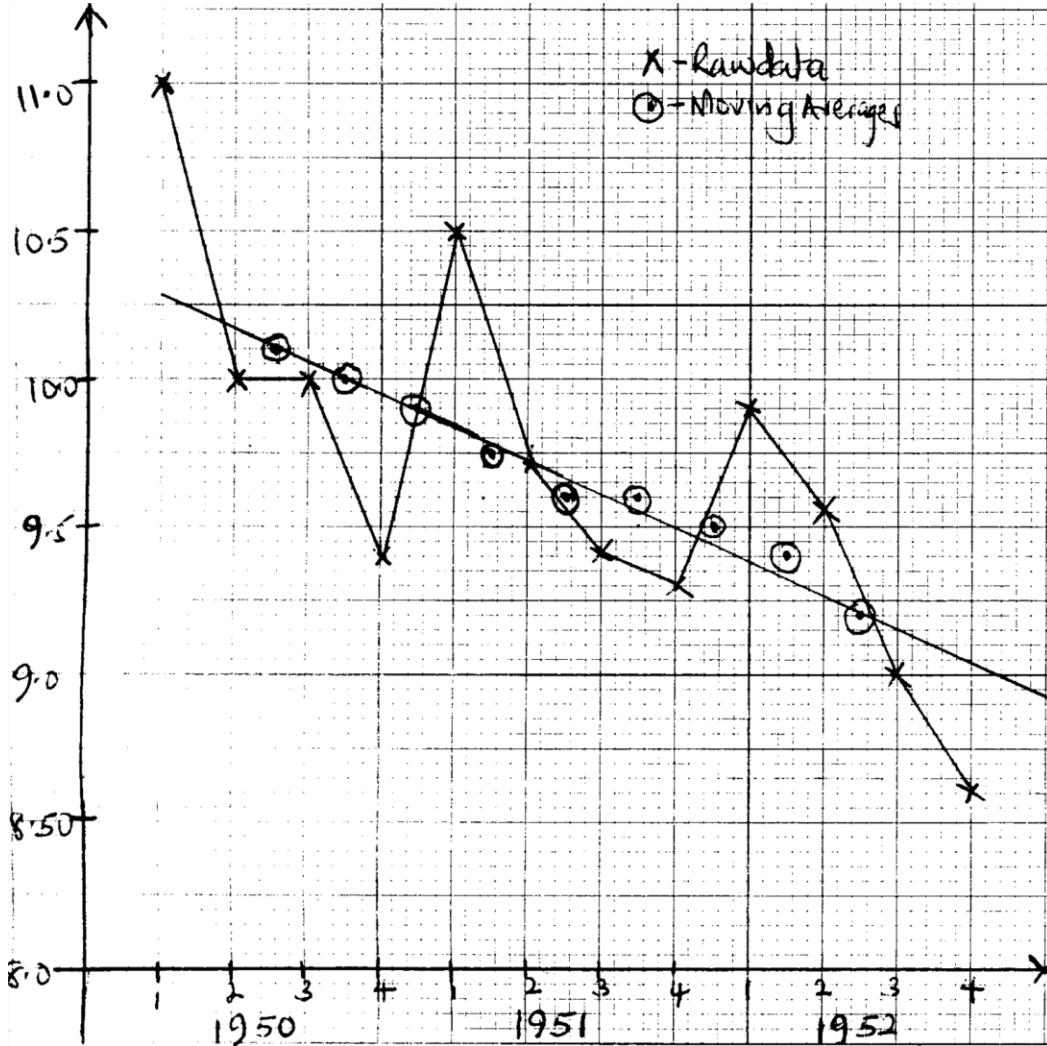

(iii) The school's earnings decrease generally over the given period

Trial questions

- The sales (in thousands of shillings) of a computer accessories company for the period 2002 to 2004 are given in the table below.

Year	QUARTERS			
	1	2	3	4
2002	1235	1242	1410	1400
2003	1275	1270	1450	1480
2004	1302	1280	1510	1500

- Calculate the four point moving averages

- b) On the same axes, plot graphs of the sales and the moving averages against time. Comment on the general trend of the sales for the three years period.
- c) 1st quarter of 2005

2. The table below shows the quarterly cost (in 1000's Uganda shillings of electricity for a house hold over a period of 3 years 1992 – 1994

Year	Quarters			
	1	2	3	4
1992	68	60	59	65
1993	82	80	80	92
1994	94	78	90	105

- a) Calculate the four point moving averages
- b) On the same axes, plot both the raw data and moving averages
- c) Comment on the cost of electricity over the period of 3 years

3. The table below shows the electricity supplied (in million kilowatts hours) to a company on a quarterly basis between 1988 and 1991

Year	QUARTERS			
	1	2	3	4
1988	8.9	7.1	6.7	9.3
1989	10.1	7.5	7.1	10.5
1990	11.7	7.5	8.3	16.9
1991	12.5	8.3	9.5	17.7

- a) Calculate the quarterly moving averages
- b) On the same axes, represent the data above and the quarterly moving averages.
Comment on the trend of power supply to the company over the four years period.
6. The average prices of a bunch of Matooke in each third of a year over a period of $3\frac{1}{3}$ years are given in Ug. Shs in the table below.

YEAR	1 st third	2 nd third	3 rd third
1998	4500	5000	5200
1999	5500	5700	6000
2000	6200	6500	6800
2001	7000	x	

- a) Calculate the 3 point moving averages
- b) On the same graph, show the raw data and the 3 point moving averages
- Hence (i) Comment on the trend of prices of Matooke for this period
- (i) Estimate the value of x (in the table)

CHAPTER 14: SCATTER GRAPHS AND CORRELATION

The relation between two variables can be shown on diagrams or graphs known as scatter diagram or graph. A scatter graph is obtained by representing the scores of one variable on the vertical axis and the other value on the horizontal axis.

Example

Draw a scatter diagram for the following data

X	1	2	3	4	5	6	7	8	9	10
Y	5	4	7	6	9	8	11	10	13	12

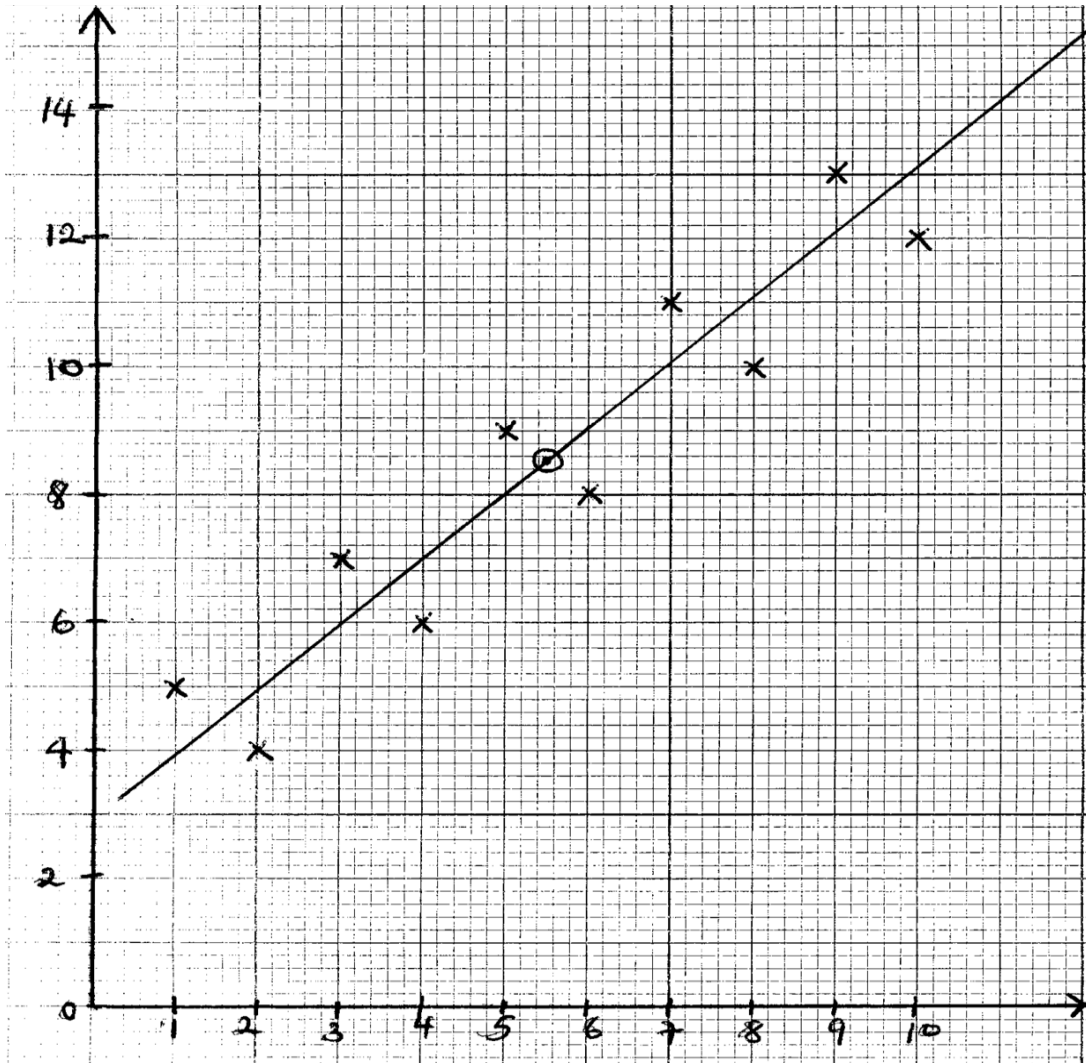
Solution**REGRESSION LINE**

When a scatter graph is plotted, a line of best fit can be drawn through the points. This line is called the regression line.

Note: The regression line should pass through the point (\bar{x}, \bar{y}) where $\bar{x} = \frac{\sum x}{n}$ and $\bar{y} = \frac{\sum y}{n}$

Example 1

In two different Athletics completion C_1 and C_2 , ten schools, A, B, C, D, E, F, G, H, I, J participated and their performances in points are given below.

COMPETITION	A	B	C	D	E	F	G	H	I	J
C_1	556	473	502	514	435	499	507	510	560	540
C_2	590	496	578	608	524	504	600	560	597	572

- Plot the points on a scatter diagram of C_2 against C_1
- Draw a line of best fit through the plotted points on your scatter diagram and estimate how many points a school would have scored in competition C_2 if it has scored 525 points in the competition C_1

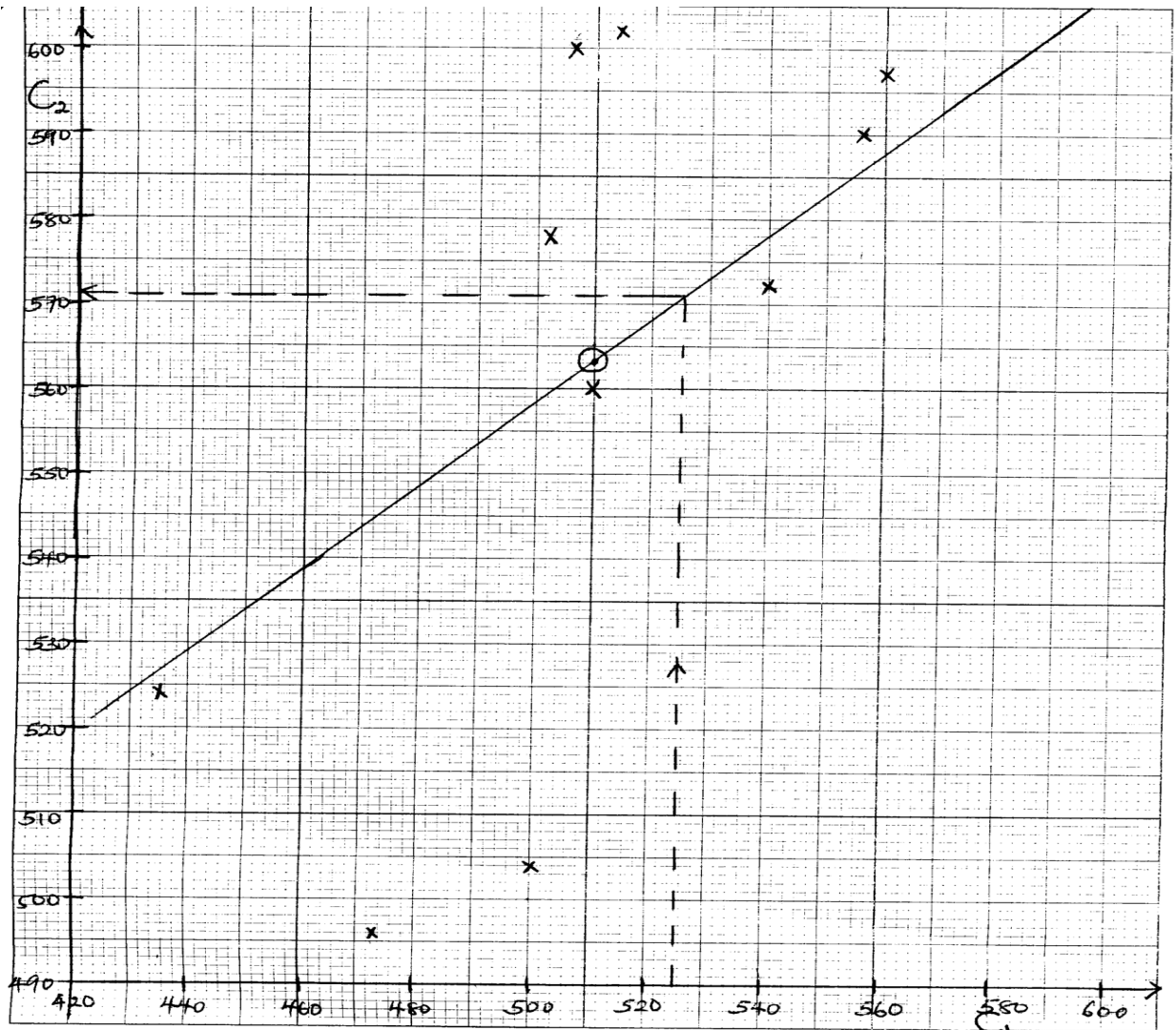
Solution

$$(ii) \bar{X} = \frac{\sum C_1}{10} = \frac{5096}{10} = 509.6$$

$$\bar{Y} = \frac{\sum C_2}{10} = \frac{5625}{10} = 562.5$$

From the graph, the school would have 571 points in C_2 if it had scored 525 points in C_1

Example 2

The table below shows the marks scored in mathematics and fine art.

Mathematics	40	48	79	26	55	35	37	70	60	40
Fine Art	59	62	68	47	46	39	63	29	55	67

Draw a scatter diagram and comment on your result

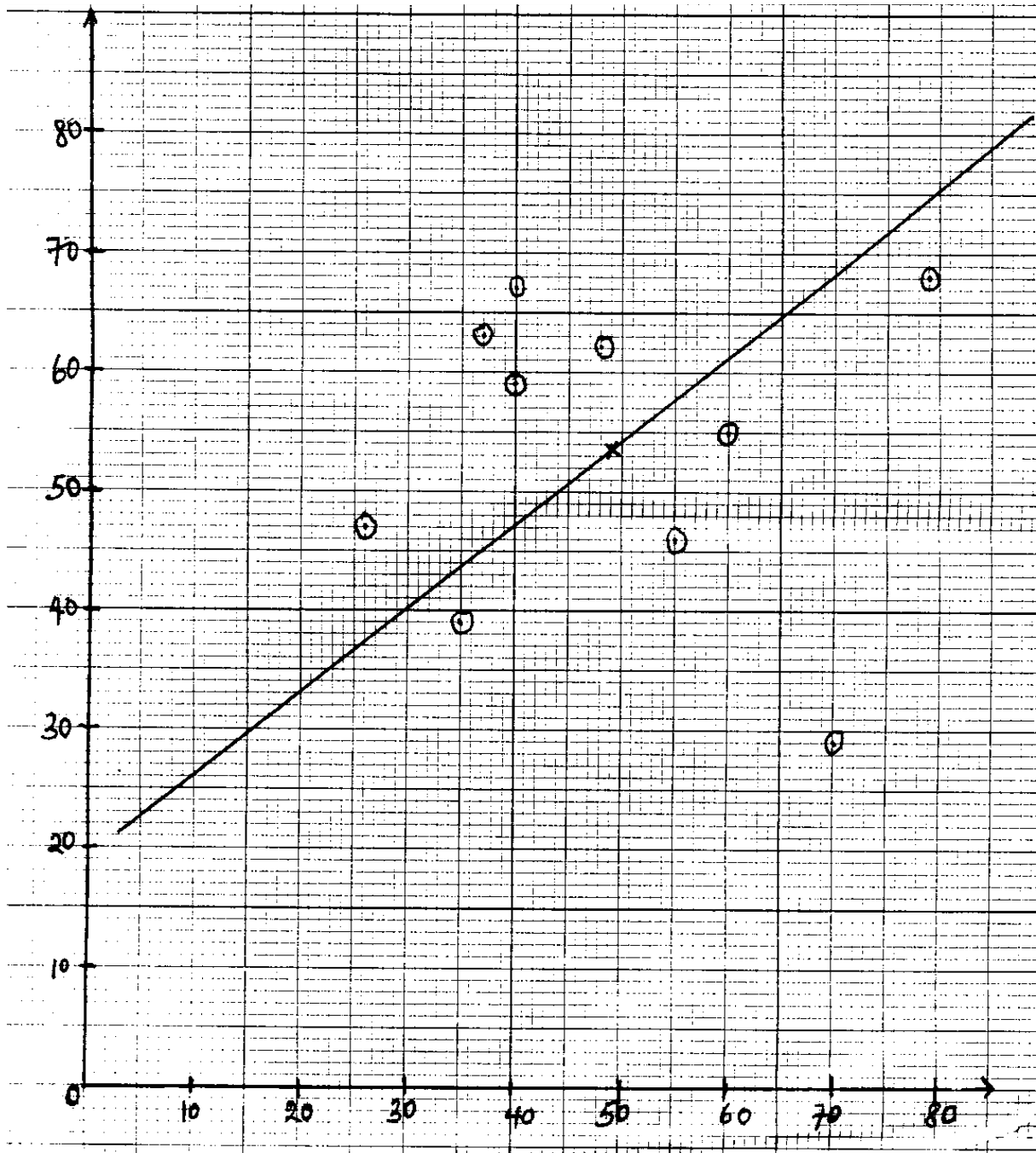

CORRELATION

Correlation is a method used to determine the relationship between two or more variables. Correlation coefficient is the index used to measure the degree of correlation

Types of correlation

Positive correlation

If y tends to increase as x increases, there is a positive correlation

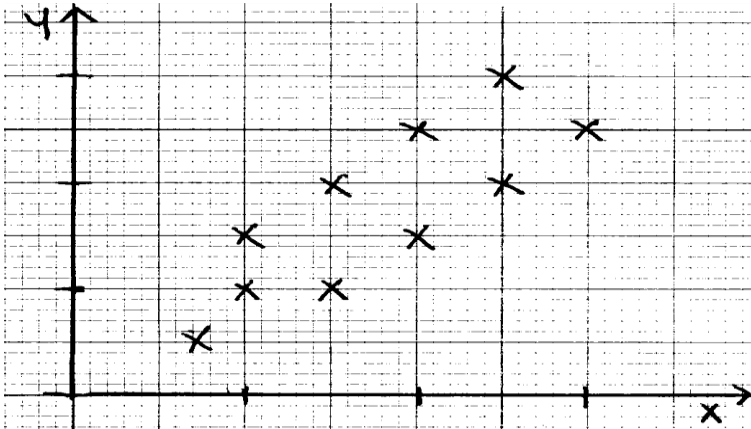

It is between 0 and 1

Negative correlation

If y tends to decrease and x increases, then there is a negative correlation.

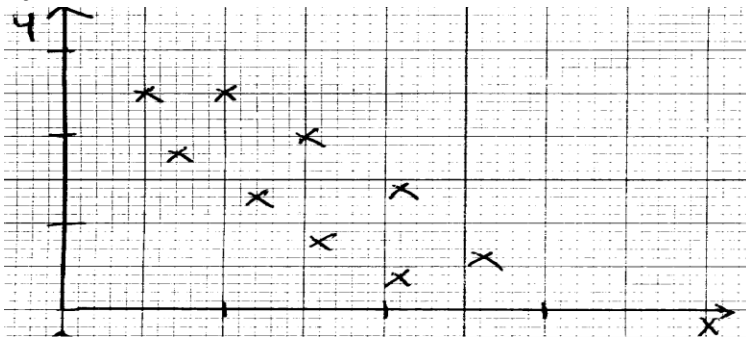

It is between -1 and 0

Zero or no correlation

If there is no relationship between x and y , then there is no correlation

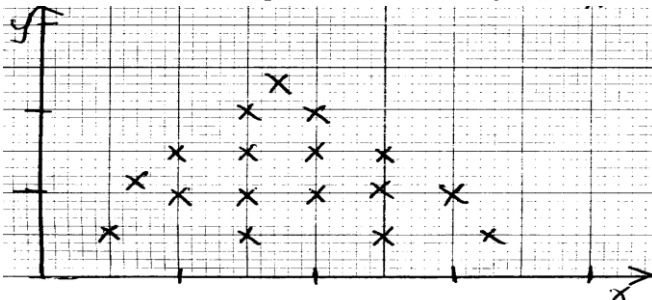

Interpretation of the magnitude of correlation coefficient.

Correlation coefficient	Interpretation
0 - 0.19	Chance correlation
0.2 - 0.39	Slight correlation
0.4 - 0.59	Moderation correlation
0.6 - 0.79	Substantial correlation
0.80 - 1.0	High correlation

Note: The sign associated with the correlation coefficient will be the one responsible for the type of coefficient. i.e. -0.85 would indicate a high negative correlation.

Rank Correlation

The degree of relationship can be calculated using the spearman's correlation coefficient (ρ) as below.

$$\text{Spearman's rank correlation coefficient, } \rho = 1 - \frac{6\sum d^2}{n(n^2-1)}$$

Where d is the difference between the rankings of a given scores and n is the number of pairs.

Example 3

Two examiners x and y each marked the scripts of ten candidates who sat a mathematics examination. The table below shows the examiners ranking of the candidates.

Examiners	A	B	C	D	E	F	G	H	I	J
X	5	3	6	1	4	7	2	10	8	9
Y	6	3	7	2	5	4	1	10	9	8

Solution

Candidate	R_x	R_y	$d=R_x-R_y$	d^2
A	5	6	-1	1
B	3	3	0	0
C	6	7	-1	1
D	1	2	-1	1
E	4	5	-1	1
F	7	4	3	9
G	2	1	1	1
H	10	10	0	1
I	8	9	-1	0
J	9	8	1	1
				$\sum d^2 = 16$

$$\rho = 1 - \frac{6\sum d^2}{n(n^2-1)} = 1 - \frac{6 \times 16}{10(100-1)} = 1 - 0.097 = 0.903$$

There is a very high positive correlation between the two examiners x and y

Example 4

The table below shows the marks of eight students in physics and mathematics. Rank the results and find the value of the rank correlation. Comment on the result.

Biology (x)	65	65	70	75	75	80	85	85
Chemistry (y)	50	55	58	55	65	58	61	65

Solution

X	Y	R_x	R_y	$d= R_x-R_y$	d^2
65	50	7.5	8	-0.5	0.25
65	55	7.5	6.5	1	1
70	58	6	4.5	-1.5	2.25
75	55	4.5	6.5	-2	4
75	65	4.5	1.5	3	9
80	58	3	4.5	-1.5	2.25
85	61	1.5	3	-1.5	2.25
85	65	1.5	1.5	0	0

$$\sum d^2 = 21$$

$$\rho = 1 - \frac{6\sum d^2}{n(n^2-1)} = 1 - \frac{6 \times 21}{8(64-1)} = 1 - 0.25 = 0.75$$

This means that there is a substantial correlation between the two subjects.

Example 5

Eight students of a certain school participated in the 1989 and 1990 national mathematics contests. Their score were as follows.

Participant	A	B	C	D	E	F	G	H
1989	72	60	56	76	68	52	80	64
1990	56	44	60	74	66	38	68	52

- Calculate the mean scores for the participants each year.
- Compute a rank correlation coefficient for the performance of the participants in the two years.
- Use the values obtained in (a) and (b) above to comment on
 - The level of difficulty of the two contests
 - Whether the two contests examined the same mathematical aptitude.

Solution

$$(a) \text{ For 1989, Mean} = \frac{72+60+56+76+68+52+80+64}{8} = \frac{528}{8} = 66$$

$$\text{For 1990, Mean} = \frac{56+44+60+74+66+38+68+52}{8} = \frac{458}{8} = 57.25$$

(b)

Participant	1989(x)	1990 (y)	R _x	R _y	d	d ²
A	72	56	3	5	-2	4
B	60	44	6	7	-1	1
C	56	60	7	4	3	9
D	76	74	2	1	1	1
E	68	66	4	3	1	1
F	52	38	8	8	0	0
G	80	68	1	2	-1	1
H	64	52	5	6	-1	1
						$\sum d^2 = 18$

$$\rho = 1 - \frac{6\sum d^2}{n(n^2-1)} = 1 - \frac{6 \times 18}{8(64-1)} = 1 - 0.2143 = 0.7857$$

- The contest in 1990 was generally harder than that of 1989
 - The two contests had the same mathematical aptitude.

Example 6

The following table gives marks (x) obtained by 12 students in an examination in statistics at the end of one term together with the marks (y) obtained at the end of the following term.

Students	A	B	C	D	E	F	G	H	I	J	K	L
Marks (x)	53	74	48	71	68	60	47	72	48	65	80	40
Marks (y)	41	50	44	38	41	48	45	57	36	46	50	47

- (i) Plot a scatter graph for the above data
- (ii) Calculate the rank correlation coefficient for the data
- (iii) What conclusions can one draw from your result in (ii) above

Solution

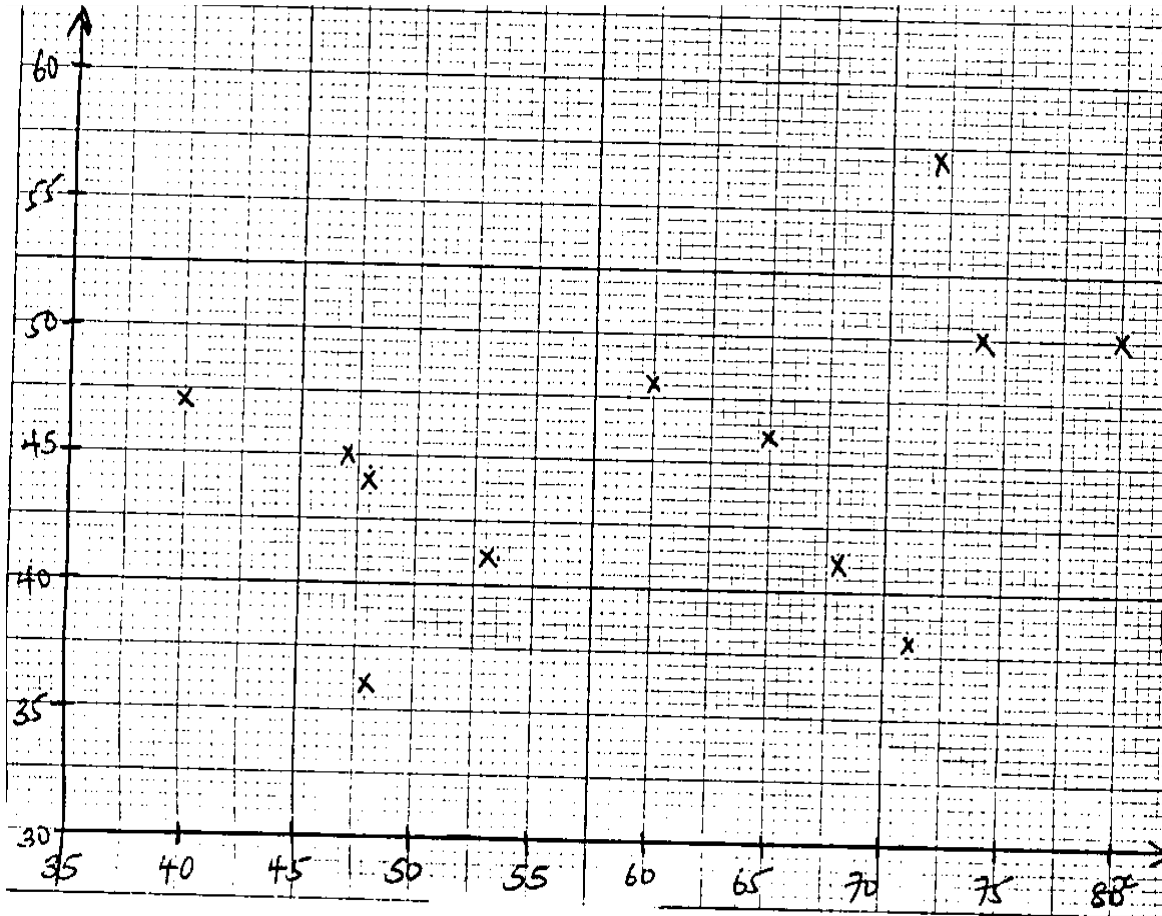

(ii)

Student	X	Y	R _x	R _y	d=R _x -R _y	d ²
A	53	41	8	9.5	-1.5	2.25
B	74	50	2	2.5	-0.5	0.25
C	48	44	9.5	8	1.5	2.25
D	71	38	4	11	-7	49
E	66	41	5	9.5	-4.5	20.25
F	60	4	7	4	3	9
G	47	45	11	7	4	16
H	72	57	3	1	2	4
I	48	36	9.5	12	-2.5	6.25
J	65	46	6	6	0	0
K	80	50	1	2.5	-1.5	2.25
L	40	47	12	5	7	49
						Σd ² =160.5

$$\rho = 1 - \frac{6\sum d^2}{n(n^2-1)} = 1 - \frac{6 \times 160.5}{12(144-1)} = 1 - 0.5612 = 0.4388$$

There is a moderate positive correlation between the marks X and Y.

Example 7

The following table gives the marks obtained in calculus, physics and statistics by seven (7) students;

Calculus	72	50	60	55	35	48	82
Physics	61	55	70	50	30	50	73
Statistics	50	40	62	70	40	40	60

Draw scatter diagrams and determine the rank correlation coefficients between the performances of the students in

- (i) Calculus and physics
- (ii) Calculus and statistics

Give interpretations to your results.

Solution

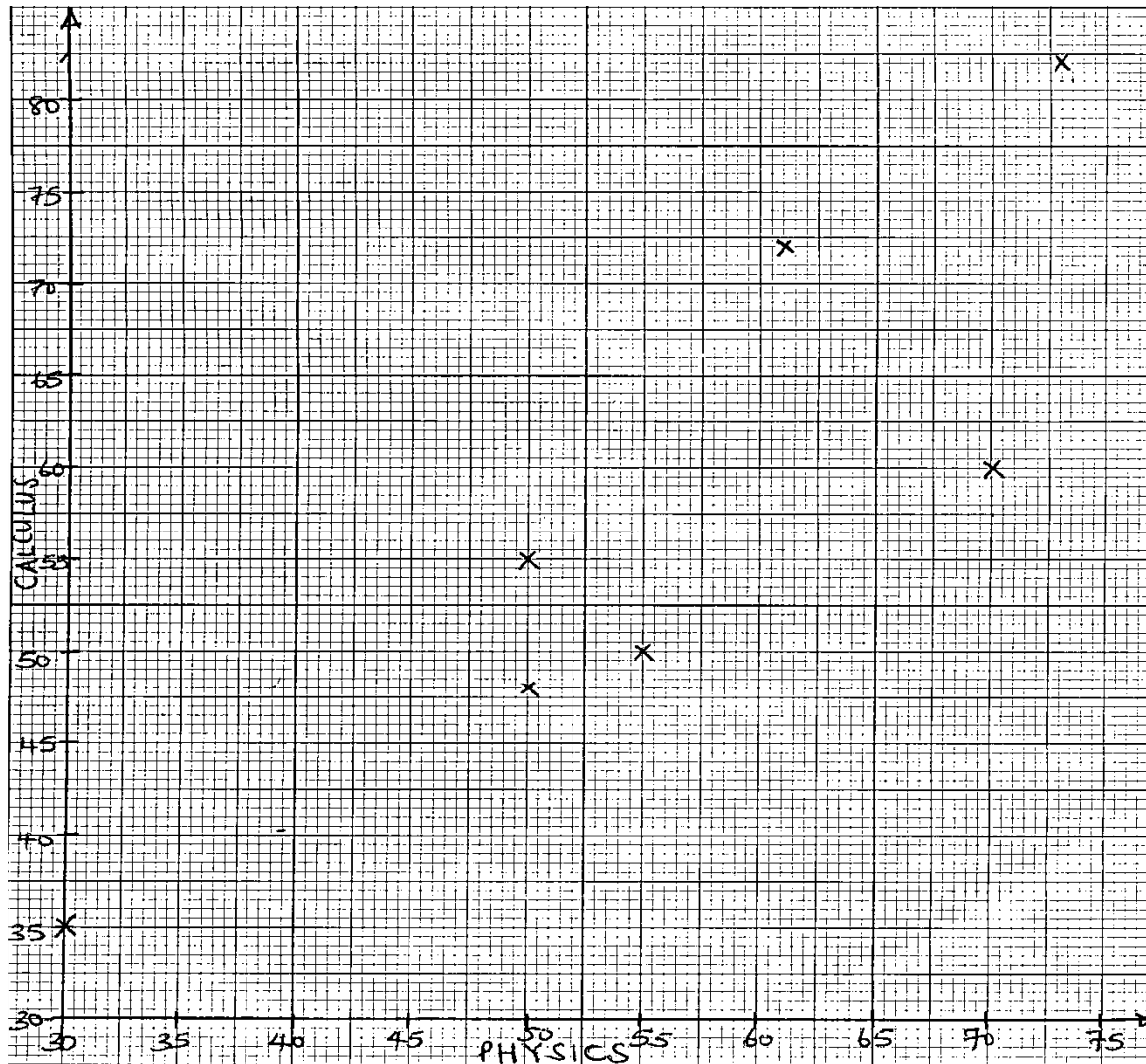

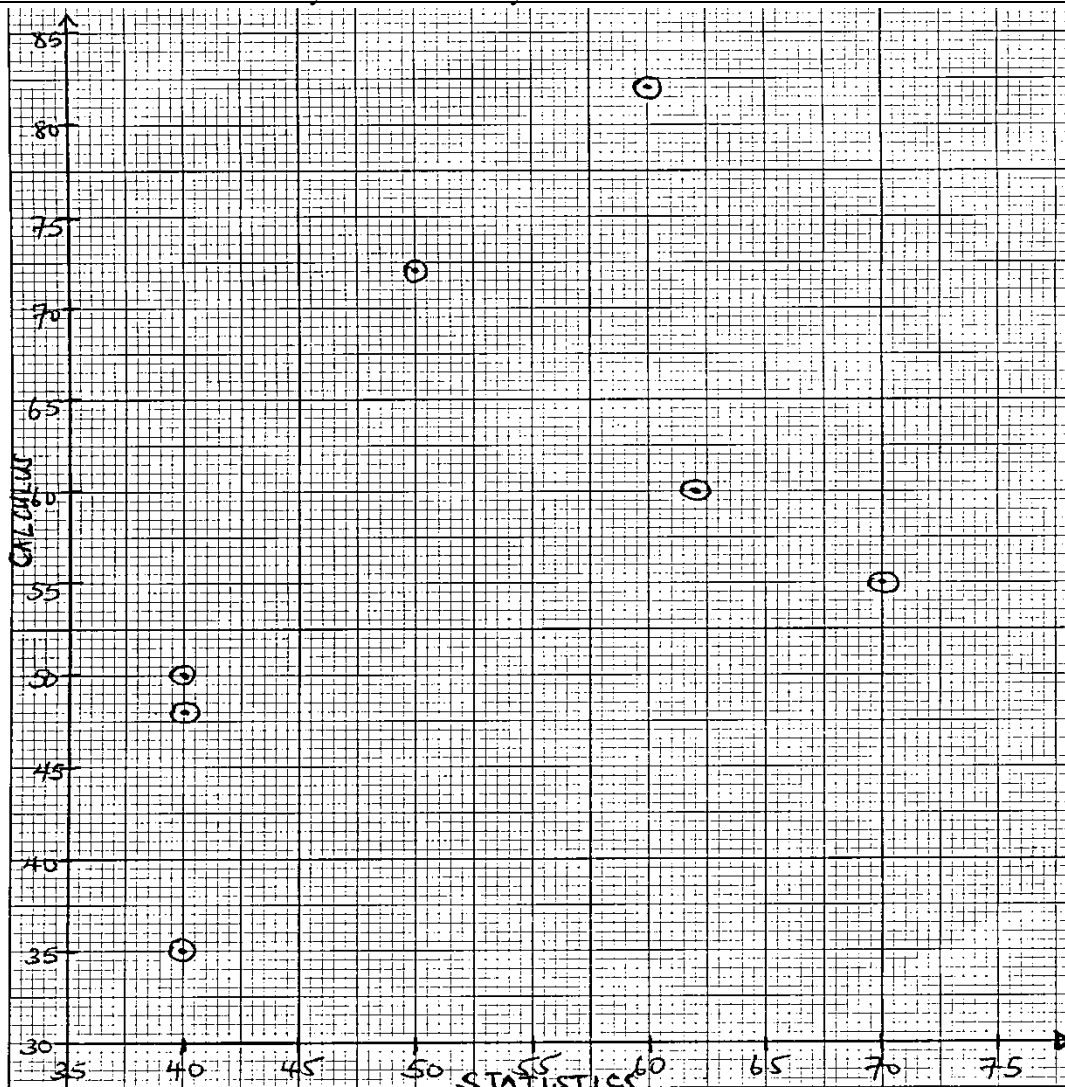

Let C= Calculus, P = Physics, S = statistics

Marks for C	Marks for P	Marks for S	R _C	R _P	R _S	d=R _C —R _P	d ²	d =R _C - R _S	d ²
72	61	50	2	3	4	-1	1	-2	4
50	55	40	5	4	6	1	1	-1	1
60	70	62	3	2	2	1	1	1	1
55	50	70	4	5.5	1	-1.5	2.25	3	9
35	30	40	7	7	6	0	0	1	1
48	50	40	6	5.5	6	0.5	0.25	0	0
82	73	60	1	1	3	0	0	-2	4
Σd^2							5.5		20

(i) Calculus and Physics

$$\rho = 1 - \frac{6 \times 5.5}{7(7^2 - 1)} = 1 - \frac{33}{336} = 0.9018$$

There is a high positive correlation

(ii) Calculus and Statistics

$$\rho = 1 - \frac{6 \times 2}{7(7^2 - 1)} = 1 - \frac{120}{336} = 0.6429$$

There is a substantial positive correlation

Example 8

The table below represents the scores obtained in biology and geography by 10 students

Biology(x)	51	63	43	60	61	32	71	40	48	59
Geography(y)	61	41	36	45	49	53	70	38	60	52

Assuming that the highest mark represents the first rank and so on.

- (a) Construct a scatter diagram and line of best fit
- (b) Calculate the spearman's rank correlation coefficient and comment on your results.

Solution

(a)

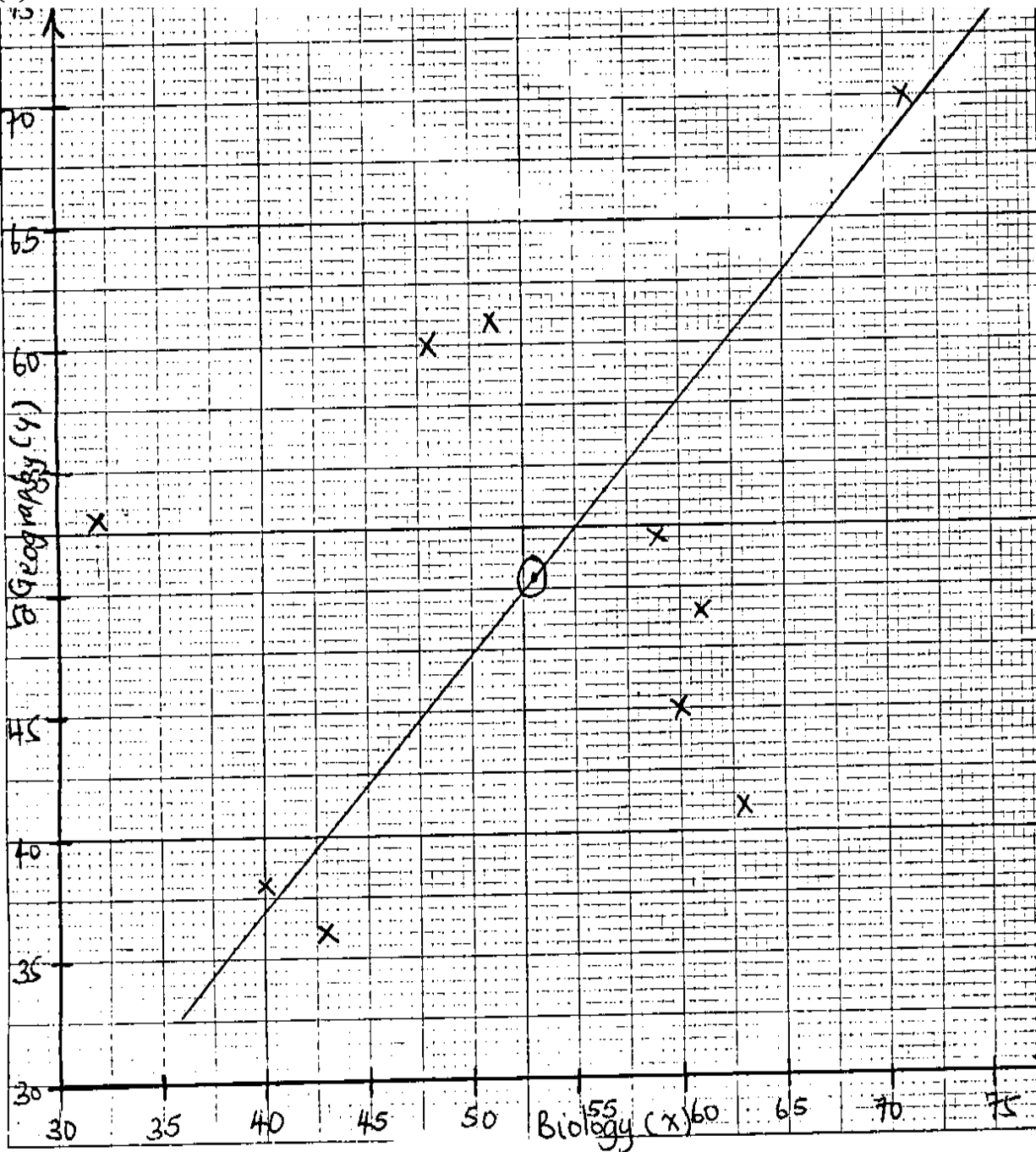

(b)

Let R_B = Rank of Biology

Let R_G = Rank of geography

R_B	R_G	$d = R_B - R_G$	d^2
6	3	3	9
2	8	-6	36
8	10	-2	4
4	7	-3	9
3	6	-3	9
10	5	5	25
1	1	0	0
9	9	0	0
7	4	3	9
5	2	3	9
Σd^2			110

$$\begin{aligned} \text{Spearman's rank correlation coefficient} &= 1 - \frac{6 \Sigma d^2}{n(n^2-1)} \\ &= 1 - \frac{6 \times 110}{10(100-1)} = 1 - \frac{660}{990} = 0.333 \end{aligned}$$

There is a slight positive correlation

Trial questions

1. The table below shows the marks scored by eight students A, B, C, D, E, F, G, H in three tests in English during the first term of the school calendar.

STUDENT	A	B	C	D	E	F	G	H
TEST I	80	70	60	74	65	65	48	58
TEST II	70	70	65	70	64	60	58	50
TEST III	75	80	86	82	70	64	60	64

- a) Calculate the rank correlation coefficient for the performance between
- Test I and test II [Ans: 0.875]
 - Test I and test III [Ans: 0.792]
- b) Comment on the relationship of the performance in three terms
2. The following are final examination scores with 12 students obtained in Psychology, x, and economics, y

X	35	56	65	78	49	82	22	90	77	35	52	93
Y	57	72	63	76	53	100	38	82	82	19	43	79

- Draw a scatter diagram for the data
- Find the rank correlation coefficient for the performance of the students in the two subjects. [Ans: 0.979]

3. The marks obtained in two tests X and Y were as follows:

X	51	62	64	47	54	44	68	61	56
Y	45	54	58	46	49	43	59	56	53

- Plot a scatter diagram and comment on your graph.

(ii) Rank the scores and calculate the rank correlation coefficient. Comment on your result.

[Ans: 0.992]

4. The marks scored by 12 students in an English and mathematics examination were:

English	74	52	43	65	39	56	48	37	52	68	45	68
Mathematics	46	56	38	42	48	51	59	54	45	51	35	61

(i) Draw a scatter diagram and comment on the performance of the students in the two subjects.

(ii) Calculate the rank correlation coefficient and comment on your result [Ans: 0.157]

5. The table below shows the percentage preference of nine most popular holiday destinations as sampled by a tour company for two years 1996 and 1997.

Holiday destination	F	G	S	I	A	Y	C	H	B
1996	90	80	78	78	50	40	30	20	10
1997	79	90	80	60	60	35	50	60	22

(i) Plot a scatter diagram for the data, and comment on the correlation between the figures for the two years.

(ii) Calculate a rank correlation coefficient [Ans: 0.8215]

6. The table below shows the height of each boy (X cm) and the distance (Y cm) to which he can throw the ball.

Boy	A	B	C	D	E	F	G	H	I	J
X (cm)	122	124	133	138	144	156	158	161	164	168
Y (cm)	41	28	52	56	29	34	59	61	63	67

(i) Draw a scatter diagram for this data

(ii) Comment on the relationship between the boys' heights and the distances they throw the ball.

(iii) Draw the line best fit. Use the line to estimate the distance the ball can be thrown a boy of height of 175 cm

c) Calculate the rank correlation coefficient between X and Y [Ans: 0.782]

7. The marks obtained by 8 students in English (X) and French (Y) are given below;

English (X)	55	42	37	59	38	48	56	48
French (Y)	60	48	41	63	35	39	51	55

(i) Plot a scatter graph for the performance of the 8 students in the two subjects. Comment on your graph

(ii) Calculate the rank correlation coefficient of the performance of the students in the two subjects. Comment on your result. [Ans: 0.768]

8. The marks obtained in Physics and Chemistry by 10 students in end of year examinations were:

Chemistry (X)	54	58	60	60	70	65	71	68	73	66
Physics (Y)	57	61	63	64	74	68	70	73	75	78

- (i) Draw a scatter diagram and comment on it.
 (ii) Calculate the rank correlation coefficient of the performance in the two subjects.

[Ans: 0.839]

9. Three examiners X, Y, and Z each marked the scripts of ten candidates who sat a mathematics examination. The table below shows the examiner's ranking of the candidates.

EAMINERS	CANDIDATES									
	A	B	C	D	E	F	G	H	I	J
X	8	5	9	2	10	1	7	6	3	4
Y	5	3	6	1	4	7	2	2	8	9
Z	6	3	7	2	5	4	1	10	9	8

Calculate the rank correlation coefficient of rankings between

- (i) X and Y [Ans: -0.127]
 (ii) Y and Z [Ans: 0.919]

10. The following table shows the marks scored by thirteen students in Biology and Chemistry tests.

Biology	40	28	28	20	21	31	22	36	29	24	30	25	27
Chemistry	40	30	28	20	22	45	25	35	27	23	31	27	26

- a) Draw a scatter diagram to represent the performance of the students in the two subjects. Comment on the relationship between performance in Biology and chemistry.
 b) Calculate the rank correlation coefficient between the marks of the two subjects.
11. The table shows the performance of ten students in their inter house music competition and their performance in their end of term mathematics test.

Student	A	B	C	D	E	F	G	H	I	J
Scores in music	280	270	276	232	250	228	182	205	220	150
Scores in Mathematics	70	64	72	68	52	55	50	48	61	40

- a) (i) Represent the graph performances in the same scatter graph
 (ii) Comment on the correlation between the performance in music competition and the mathematics test.
 b) Calculate the rank correlation coefficient between the students' performance in music competition and their performance in end of term mathematics. Comment on this result [Ans: 0.867]

12. The table below shows the marks of 10 students in three papers

	A	B	C	D	E	F	G	H	I	J
Paper i	81	42	55	67	36	46	59	78	30	67
Paper ii	64	50	54	70	48	32	49	54	46	58
Paper iii	59	47	78	43	60	54	31	52	68	62

- a) Calculate the rank correlation coefficient between
 (i) Paper i and paper ii [Ans: 0.764]

(ii) Paper ii and paper iii [Ans: -0.161]

(iii) Comment on the relationship between the performance in paper I and the other two papers ii and iii

13. Eight applicants for a certain job obtained the following marks I aptitude and written tests

Applicant	A	B	C	D	E	F	G	H
Aptitude test	33	45	15	42	45	35	40	48
Written test	57	60	40	75	58	48	54	68

Calculate a rank correlation coefficient of the applicant's performance in the two tests. Comment on your result. [Ans: 0.78]

14. The table below shows the percentage of sand y in the soil at different depths X (in cm)

Soil depth(X) (cm)	35	65	55	25	45	75	20	90	51	60
Percentage of sand (Y)	86	70	84	92	79	68	96	58	86	77

(a) (i) Plot a scatter diagram for the data. Comment on the relationship between the depth of the soil and the percentage of sand in the soil.

(ii) Draw a line of best fit through the points of the scatter diagram. Use it to estimate

-Percentage of the sand in the soil at the depth of 31cm

-Depth of the soil with 54% sand

b) Calculate a rank correlation coefficient between the percentage of sand in the soil and the depth of the soil.

15. Given the variables x and y below;

X	80	75	86	60	75	92	86	50	64	75
Y	62	58	60	45	68	68	81	48	50	70

Obtain a rank correlation coefficient between the variable X and Y . Comment on your result

[Ans: 0.715]

CHAPTER 15: THE PROBABILITY THEORY

Probability theory is a branch of mathematics concerned with prediction or uncertainty.

The term probability arose from the games of chance and gambling i.e. tossing a coin, rolling a die, playing cards etc.

The probability of an event is the measure of the likelihood that it will occur and it is given on a numerical scale from 0 to 1. The numbers representing probabilities can be written as percentages, fractions or decimals

- A probability of zero implies that the event is impossible
- A probability of one (100%) indicates that the event is certain to occur.
- All other events have a probability between 0 and 1

Sample space and generation of the sample space

Sample space (S) is the set of all possible outcomes of an experiment. Each possible outcome is called a sample point

Example

Rolling a die; $S = (1, 2, 3, 4, 5, 6)$

Tossing a coin; $S = (H, T)$

Note: 1, 2, 3, 4, 5, 6 and H, T are sample points

Generation of the sample space

The ways of generating a sample space include the following;

- (i) Table of out comes
- (ii) Permutations
- (iii) Tree diagram

Terms used in the set theory

An event is a subset of a sample space

Intersection of events

Consider A and B as two events of a sample space S, the intersection of these two events is given by $A \cap B$ i.e. containing sample points common to both A and B

Union of events

This is a set of all sample points in either A or B or both .It is denoted by $A \cup B$

Complement of an event

If A is an event of a sample space S, the compliment of A is given by the set containing all sample points in S that are not in A. It is denoted by A' .

Mutually exclusive events

If two events A and B have no sample points in common i.e. if $A \cap B = \{ \}$ or they cannot occur at the same time i.e. Zero, then we say that A and B are mutually exclusive .

Probability function

The probability function of an event A is denoted by $P(A)$ and is the sum of the probabilities of the sample points in A. (i) $P(A) \leq 1$ (ii) $P(A) \geq 0$ (iii) $P(S) = 1$

$$P(A) = \frac{n(A)}{n(S)}$$

Example 1

Find the probability of choosing a defective pen in a lot of 12 out of which 4 are defective, if a single draw is made

Solution

No. of ways the event can happen = 4

Total no. of possibilities = 12

Hence probability = $\frac{4}{12} = \frac{1}{3}$

Example 2

What is the probability of throwing a number greater than 4 for a die whose faces are numbered from 1 to 6?

Solution

$S = \{1, 2, 3, 4, 5, 6\}$ $n(S) = 6$

$A = \{5, 6\}$ $n(A) = 2$

$P(A) = \frac{2}{6} = \frac{1}{3}$

Interaction with the set theory

The following results can be deduced from the set theory

Result 1

For any two events A and B; $P(A) = P(A \cap B) + P(A \cap B')$

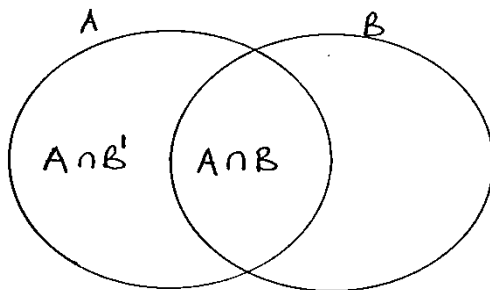
**Result 2**

For any two events A and B; $P(B) = P(A \cap B) + P(A' \cap B)$

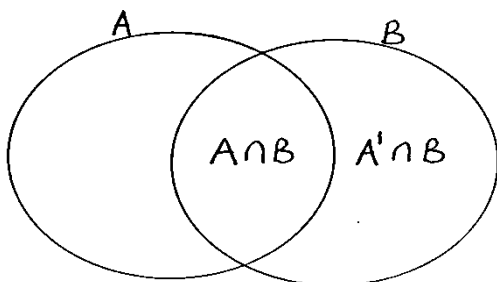

Result 3

$$P(A') = P(A' \cap B) + P(A' \cap B')$$

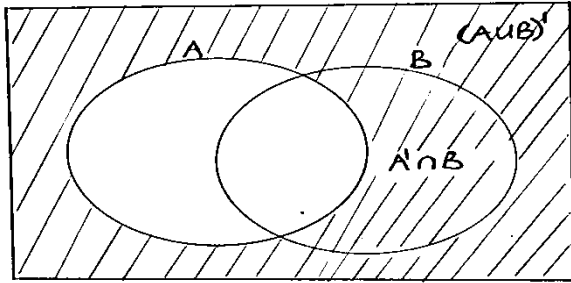

Note that $(A \cup B)' = A' \cap B'$

Result 4

$$P(B') = P(A \cap B') + P(A' \cap B')$$

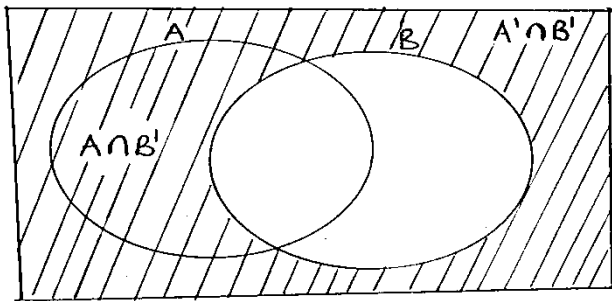

Result 5

$$P(A \cup B) = P(A) + P(B) - P(A \cap B)$$

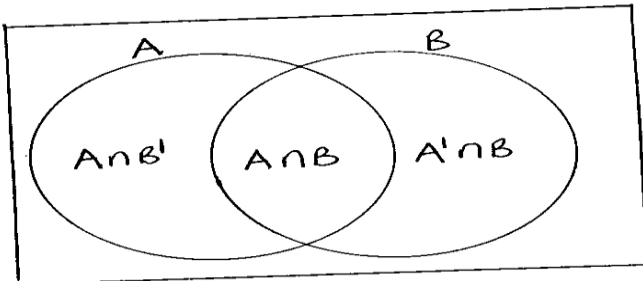

Result 6

For any events

- (i) $P(A \cup B)' = P(A' \cap B')$
- (ii) $P(A' \cup B') = P(A \cap B)'$

The contingency table

The alternative way of recalling the first four results is by using the contingency table

	A	A'	
B	$P(A \cap B)$	$P(A' \cap B)$	$P(B)$
B'	$P(A \cap B')$	$P(A' \cap B')$	$P(B')$
	$P(A)$	$P(A')$	1

$$P(A) + P(A') = 1 \text{ and } P(B) + P(B') = 1$$

Example 1

Events A and B are such that $P(A) = \frac{19}{30}$, $P(B) = \frac{2}{5}$ and $P(A \cup B) = \frac{4}{5}$. Find $P(A \cap B)$

Solution

$$\begin{aligned} P(A \cup B) &= P(A) + P(B) - P(A \cap B) \\ P(A \cap B) &= P(A) + P(B) - P(A \cup B) \\ &= \frac{19}{30} + \frac{2}{5} - \frac{4}{5} = \frac{7}{30} \end{aligned}$$

Example 2

The probability that a student passes mathematics is $\frac{2}{3}$ and the probability that he passes physics is $\frac{4}{9}$. If the probability that he passes at least one of them is $\frac{4}{5}$, find the probability that he passes both papers

Solution

Let M denote event passing mathematics and P denote event passing physics

$$P(M) = \frac{2}{3} \quad P(P) = \frac{4}{9} \quad P(M \cup P) = \frac{4}{5}$$

From $P(M \cup P) = P(M) + P(P) - P(M \cap P)$

$$\begin{aligned} P(M \cap P) &= P(M) + P(P) - P(M \cup P) \\ &= \frac{2}{3} + \frac{4}{9} - \frac{4}{5} = \frac{14}{45} \end{aligned}$$

Example 3

Given that A and B are mutually exclusive events such that $P(A) = 0.5$, $P(A \cup B) = 0.9$, find

(i) $P(A' \cup B)$

(ii) $P(A' \cap B')$

Solution

(i) For mutually exclusive events, $P(A \cap B) = 0$

$$\begin{aligned} P(A \cup B) &= P(A) + P(B) \Rightarrow P(B) = P(A \cup B) - P(A) \\ &= 0.9 - 0.5 = 0.4 \end{aligned}$$

$$P(A' \cup B) = P(A') + P(B) - P(A' \cap B)$$

$$\begin{aligned} P(A' \cap B) &= P(B) - P(A \cap B) \\ &= 0.4 - 0 = 0.4 \end{aligned}$$

$$P(A') = 1 - P(A) = 1 - 0.5 = 0.5$$

$$\begin{aligned} P(A' \cup B) &= 0.5 + 0.4 - 0.4 \\ &= 0.5 \end{aligned}$$

$$\begin{aligned} \text{(ii)} \quad P(A' \cap B') &= P((A \cup B)') = 1 - P(A \cup B) \\ &= 1 - 0.9 = 0.1 \end{aligned}$$

Example 4

A and B are mutually exclusive events such that $P(A) = 0.3$, $P(B) = 0.5$. Find

(i) $P(A \cup B)$

(ii) $P(A')$

(iii) $P(A' \cap B')$

Solution

(i) $P(A \cap B) = 0$

$$\begin{aligned} P(A \cup B) &= P(A) + P(B) \\ &= 0.3 + 0.5 \end{aligned}$$

$$= 0.8$$

$$(ii) \quad P(A') = 1 - P(A) = 1 - 0.3 = 0.7$$

$$(iii) \quad P(B) = P(A \cap B) + P(A' \cap B)$$

$$P(A' \cap B) = P(B) - P(A \cap B)$$

$$P(A' \cap B) = 0.5 - 0 = 0.5$$

$$\text{From } P(A') = P(A' \cap B') + P(A' \cap B)$$

$$P(A' \cap B') = P(A') - P(A' \cap B)$$

$$= 0.7 - 0.5 = 0.2$$

Example 5

Given that A and B are mutually exclusive events and that $P(A) = \frac{2}{5}$ and $P(B) = \frac{1}{2}$. Find

$$(i) \quad P(A \cup B) \quad (ii) \quad P(A \cap B') \quad (iii) \quad P(A' \cap B')$$

Solution

$$(i) \quad P(A \cup B) = P(A) + P(B)$$

$$= \frac{2}{5} + \frac{1}{2} = \frac{9}{10}$$

$$(ii) \quad P(A) = P(A \cap B') + P(A \cap B)$$

$$\Rightarrow P(A \cap B') = P(A) - P(A \cap B)$$

$$= \frac{2}{5} - 0 = \frac{2}{5}$$

$$(iii) \quad P(B') = P(A \cap B') + P(A' \cap B')$$

$$P(A' \cap B') = P(B') - P(A \cap B')$$

$$P(B') = 1 - P(B) = 1 - \frac{1}{2} = \frac{1}{2}$$

$$P(A' \cap B') = \frac{1}{2} - \frac{2}{5} = \frac{1}{10}$$

Probability situations

The And situation

- When there is joint occurrence of events
- Considering a sequence of events

Example

In a class of 100 students, 70 offer economics while 50 students offer mathematics. Each student offers at least one of the subjects. Determine the probability for the number of students who offer both subjects

Solution

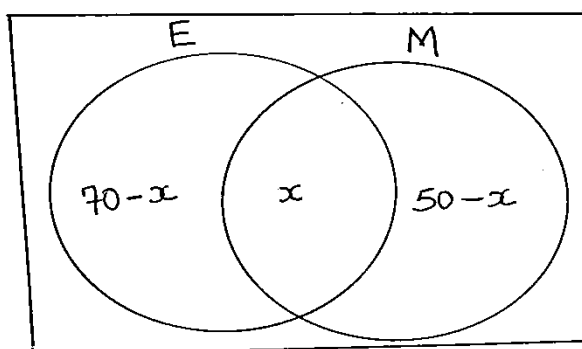

$$70 - x + x + 50 - x = 100$$

$$120 - x = 100$$

$$x = 20$$

$$P(E \cap M) = \frac{20}{100} = 0.2$$

The Or situation

If A and B are two events, the probability that either event A or B or even both occurs is denoted $P(A \cup B)$

$$\text{But } P(A \cup B) = P(A) + P(B) - P(A \cap B)$$

Example

Two dice are thrown, what is the probability of scoring either a double or a sum greater than 8?

Solution

A table of outcomes can be used to generate the sample space

		First die					
		1,1	1,2	1,3	1,4	1,5	1,6
Second die	2,1	2,1	2,2	2,3	2,4	2,5	2,6
	3,1	3,1	3,2	3,3	3,4	3,5	3,6
	4,1	4,1	4,2	4,3	4,4	4,5	4,6
	5,1	5,1	5,2	5,3	5,4	5,5	5,6
	6,1	6,1	6,2	6,3	6,4	6,5	6,6

Table of sums

2	3	4	5	6	7
3	4	5	6	7	8
4	5	6	7	8	9
5	6	7	8	9	10
6	7	8	9	10	11
7	8	9	10	11	12

$$E_1 = \{(1,1)(2,2)(3,3)(4,4)(5,5)(6,6)\}$$

$$n(E_1) = 6$$

$$E_2 = \{(3,6)(4,5)(4,6)(5,4)(5,5)(5,6)(6,3)(6,4)(6,5)(6,6)\}$$

$$n(E_2) = 10$$

$$n(E_1 \cap E_2) = 2$$

$$P(E_1 \cup E_2) = P(E_1) + P(E_2) - P(E_1 \cap E_2)$$

$$= \frac{6}{36} + \frac{10}{36} - \frac{2}{36} = \frac{14}{36} = \frac{7}{18}$$

Independent events

Independent events are events such that the occurrence of one does not affect/influence the occurrence of the other. Two events A and B are said to be independent if and only if $P(A \text{ and } B) = P(A \cap B) = P(A) \cdot P(B)$

Example 1

Two events A and B are independent such that $P(B) = 0.6$ and $P(A \cup B) = 0.94$. Find

(i) $P(A)$

(ii) $P(A \cap B)$

Solution

(i) $P(A \cup B) = P(A) + P(B) - P(A \cap B)$

But $P(A \cap B) = P(A) \cdot P(B)$

$$\begin{aligned} \Rightarrow P(A \cup B) &= P(A) + P(B) - P(A) \cdot P(B) \\ 0.94 &= P(A) + 0.6 - 0.6P(A) \\ 0.34 &= 0.4P(A) \\ P(A) &= 0.85 \end{aligned}$$

(ii) $P(A \cap B) = P(A) \times P(B)$
 $= 0.85 \times 0.6$
 $= 0.51$

Example 2

Given that A and B are events such that $P(A) = \frac{2}{3}$ and $P(B) = \frac{1}{5}$. Find

- (i) $P(A \cup B)$ if A and B are mutually exclusive
- (ii) $P(A \cap B')$ and $P(A' \cap B')$ if A and B are independent events

Solution

(i) $P(A \cap B) = 0$

$$\begin{aligned} \Rightarrow P(A \cup B) &= P(A) + P(B) \\ &= \frac{2}{3} + \frac{1}{5} = \frac{13}{15} \end{aligned}$$

(ii) $P(A \cap B) = P(A) \times P(B) = \frac{2}{3} \times \frac{1}{5} = \frac{2}{15}$
 From $P(A) = P(A \cap B) + P(A \cap B')$
 $\Rightarrow P(A \cap B') = P(A) - P(A \cap B)$
 $= \frac{2}{3} - \frac{2}{15} = \frac{8}{15}$

From $P(B') = P(A \cap B') + P(A' \cap B')$
 $P(A' \cap B') = P(B') - P(A \cap B')$
 But $P(B') = 1 - P(B) = 1 - \frac{1}{5} = \frac{4}{5}$
 $P(A' \cap B') = \frac{4}{5} - \frac{8}{15} = \frac{4}{15}$

Example 3

One element is randomly selected from a universal set of 20 elements. Sets A and B are subsets of the universal set and $n(A) = 15$, $n(B) = 10$ and $n(A \cap B) = 7$. If P(A) is the probability of the selected element belonging to set A, find (a) P(A) (b) P(A ∩ B) (c) P(A') (d) P(A ∪ B)

Solution

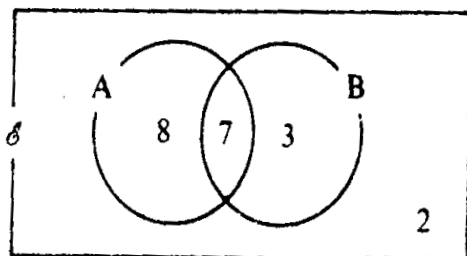

(a) $P(A) = \frac{15}{20} = \frac{3}{4}$

$$(b) P(A \cap B) = \frac{7}{20}$$

$$(c) P(A') = \frac{5}{20} = \frac{1}{4}$$

$$(d) P(A \cup B) = \frac{18}{20} = \frac{9}{10}$$

Example 4

If A and B are two events such that $P(A) = \frac{1}{4}$, $P(B) = \frac{1}{2}$ and $P(A \cap B) = \frac{1}{8}$. Find (a) $P(A \cup B)$,

(b) $P(A \cup B)'$

Solution**Method I**

$$(a) P(A \cup B) = P(A) + P(B) - P(A \cap B)$$

$$= \frac{1}{4} + \frac{1}{2} - \frac{1}{8} = \frac{5}{8}$$

$$(b) P(A \cup B)' = 1 - P(A \cup B) = 1 - \frac{5}{8} = \frac{3}{8}$$

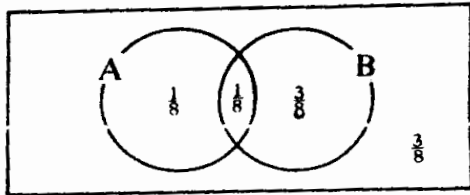
Method II

$$(a) P(A \cup B) = \frac{3}{8} + \frac{1}{8} + \frac{1}{8} = \frac{5}{8}$$

$$(b) P(A \cup B)' = \frac{3}{8}$$

Conditional probability

The conditional probability of an event B in relation to an event A is the probability that event B occurs after or given that A has already occurred. If A and B are events, then the conditional probability of A given B denoted as $P(A/B)$ is $\frac{P(A \cap B)}{P(B)}$ provided $P(B) \neq 0$

Example

The probability that a regular scheduled flight departs on time is 0.83 and the probability that it arrives on time is 0.92. The probability that it departs on time and arrives on time is 0.78. Find the probability that the plane;

- (i) Arrives on time given that it departs on time
- (ii) Departs on time given that it arrives on time

Solution

Let D denote event departs on time $\Rightarrow P(D) = 0.83$

Let A denote event arrives on time $\Rightarrow P(A) = 0.92$

$$P(A \cap D) = P(D \cap A) = 0.78$$

$$(i) P(A/D) = \frac{P(A \cap D)}{P(D)} = \frac{0.78}{0.83} = 0.94$$

$$(ii) \quad P(D/A) = \frac{P(D \cap A)}{P(A)} = \frac{0.78}{0.92} = 0.85$$

Example 2

Events A and B are such that $P(A) = \frac{1}{2}$, $P(B) = \frac{3}{8}$ and $P(A/B) = \frac{7}{12}$. Find

- (i) $P(A \cap B)$
(ii) $P(B/A')$

Solution

$$(i) \quad P(A/B) = \frac{P(A \cap B)}{P(B)} = \frac{7}{12}$$

$$P(A \cap B) = \frac{7}{12} P(B) = \frac{7}{12} \times \frac{3}{8} = \frac{7}{32}$$

$$(ii) \quad P(B/A') = \frac{P(B \cap A')}{P(A')}$$

$$P(A') = 1 - P(A) = 1 - \frac{1}{2} = \frac{1}{2}$$

$$\text{But } P(B \cap A') = P(A' \cap B) = P(B) - P(A \cap B)$$

$$= \frac{3}{8} - \frac{7}{32} = \frac{5}{32}$$

$$P(B/A') = \frac{5/32}{1/2} = \frac{5}{32} \times \frac{2}{1} = \frac{5}{16}$$

Probability tree diagrams

Tree diagrams can be used to obtain the possible outcomes of an experiment or generate a sample space

Example

Find the possible outcomes for a family that plans to have three children

Solution

The possible outcomes are $\{BBB, BBG, BGB, BGG, GBB, GBG, GGB, GGG\}$

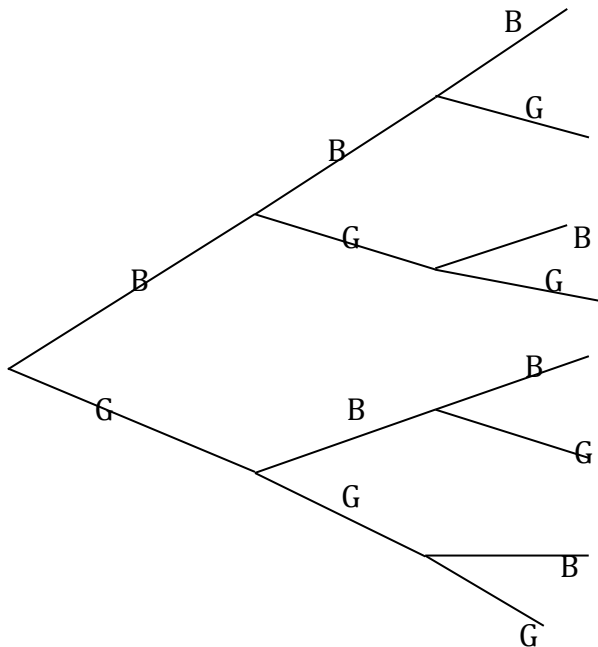

The possible outcomes when three coins are tossed are

{HHH, HHT, HTH, HTT, THH, THT, TTH, TTT}

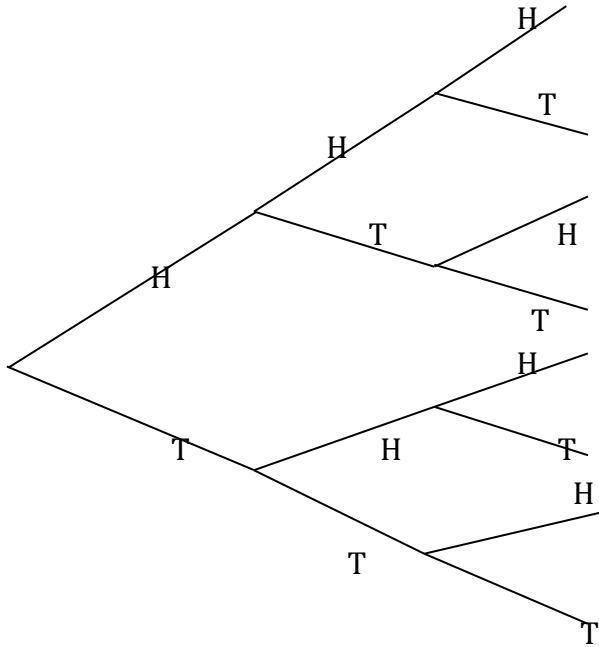

Note:

- (i) The total probability for any one set of branches = 1
- (ii) The sum of the final probabilities = 1
- (iii) The tree shows conditional probabilities

Example 1

The proportion of female students at Makerere University is 55%. If 30% of male students and 55% of female students study computer. What is the probability that a computer student chosen at random is a female.

Solution

Let F denote female and M denote male student and let C denote studying computer

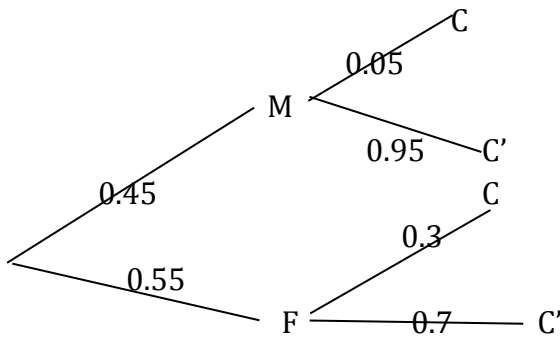

$$P(F/C) = \frac{P(F \cap C)}{P(C)}$$

$$P(C) = P(F \cap C) + P(M \cap C)$$

$$= 0.55 \times 0.05 + 0.45 \times 0.3 = 0.1625$$

$$P(F/C) = \frac{0.55 \times 0.05}{0.1625} = 0.1692$$

Example 2

A bag contains 8 marbles of which three are red and 5 blue. One marble is drawn at random, its colour noted and the marble replaced in the bag. A marble is again drawn from the bag and its colour noted. Find the probability that the marbles drawn will be (a) red followed by blue (b) red and blue in any order (c) Of the same colour.

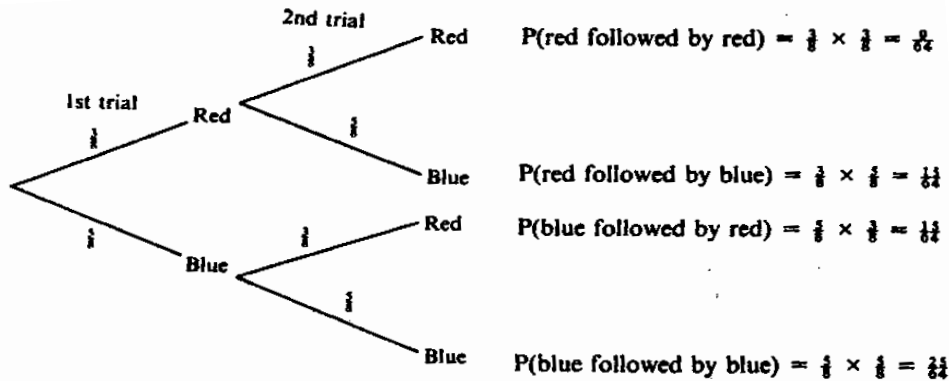
Solution

(a) $P(\text{red followed by blue}) = \frac{15}{64}$

(b) $P(\text{red and blue in any order}) = \frac{15}{64} + \frac{15}{64} = \frac{30}{64}$

(c) $P(\text{both of same colour}) = \frac{9}{64} + \frac{25}{64} = \frac{34}{64}$

(a) $P(\text{red followed by blue}) = \frac{15}{64}$

(b) $P(\text{red and blue in any order}) = \frac{15}{64} + \frac{15}{64} = \frac{30}{64}$

(c) $P(\text{both of the same colour}) = \frac{9}{64} + \frac{25}{64} = \frac{34}{64}$

Example 3

A bag contains 7 discs, 2 of which are red and 5 are green. Two discs are removed at random without replacement and their colours noted. Find the probability that the discs will be (a) both red (b) of different colours (c) the same colour

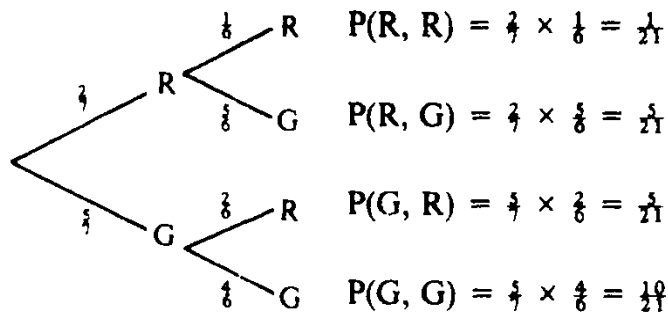
Solution

(a) $P(R, R) = \frac{1}{21}$

(b) $P(\text{different}) = P(R, G) + P(G, R)$

$$= \frac{5}{21} + \frac{5}{21}$$

$$= \frac{10}{21}$$

(c) $P(\text{same}) = P(R, R) + P(G, G)$

$$= \frac{1}{21} + \frac{10}{21}$$

$$= \frac{11}{21}$$

Example 4

The probability that it will be sunny tomorrow is $\frac{1}{3}$. If it is sunny, the probability that Viviane plays tennis is $\frac{4}{5}$. If it is not sunny, the probability that she plays tennis is $\frac{2}{5}$. Find the probability that Viviane plays tennis tomorrow.

Solution

Let S denote sunny and T denote playing tennis

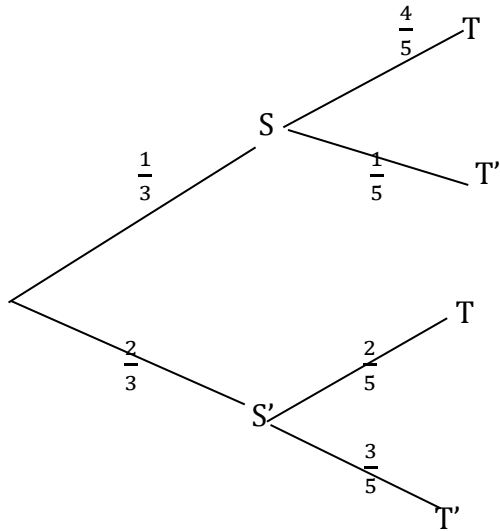

$$P(T) = P(S \cap T) + P(S' \cap T)$$

$$= \frac{1}{3} \times \frac{4}{5} + \frac{2}{3} \times \frac{2}{5} = \frac{4}{15} + \frac{4}{15} = \frac{8}{15}$$

Example 5

A box contains ten green and six white marbles. A marble is chosen at random, its colour noted and it is not replaced. This is repeated once more. What is the probability that the marbles chosen are of the same colour?

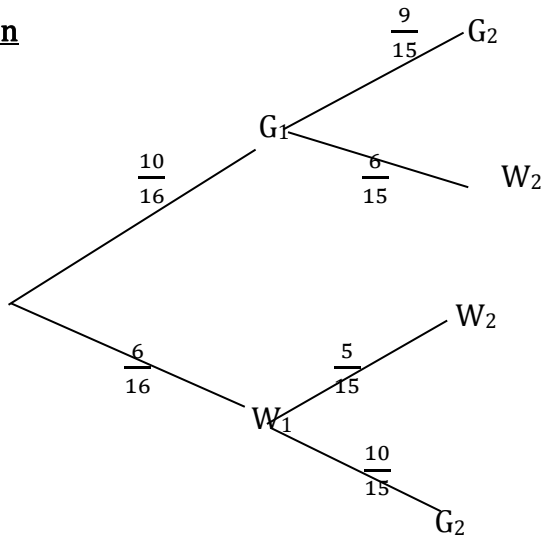
Solution

$$P(\text{marble of the same colour}) = P(W_1 \cap W_2) + P(G_1 \cap G_2)$$

$$= \frac{6}{16} \times \frac{5}{15} + \frac{10}{16} \times \frac{9}{15}$$

$$= \frac{1}{8} + \frac{3}{8} = \frac{1}{2}$$

Trial questions

- If $P(A) = \frac{3}{5}$ and $P(B) = \frac{1}{3}$, find (a) $P(A \cup B)$ if A and B are mutually exclusive events (b) $P(A \cap B)$ if A and B are independent events [Ans: (a) $\frac{14}{5}$ (b) $\frac{1}{5}$]
- Given that $P(A) = \frac{2}{3}$, $P(B) = \frac{1}{2}$, $P(A \cap B) = \frac{1}{3}$ and $P(A \cup B) = \frac{5}{6}$ state whether each of the following are true /false:
 (a) A and B are mutually exclusive events,
 (b) A and B are independent events [Ans : (a) False (b) True]
- If A and B are independent events such that $P(A) = \frac{1}{2}$ $P(B) = \frac{1}{4}$, find (a) $P(A \cap B)$ (b) $P(A \cup B)$.
 [Ans : (a) $\frac{1}{8}$ (b) $\frac{5}{8}$]
- A bag contains 9 discs, 2 of which are green and 7 yellow. Two discs are removed at random in succession, without replacement. Find the probability that the discs will (a) both be green (b) be of the same colour (c) be of different colours
 [Ans: (a) $\frac{1}{36}$ (b) $\frac{11}{18}$ (c) $\frac{7}{18}$]
- If A and B are two events such that $P(A) = \frac{5}{8}$ and $P(B/A) = \frac{3}{7}$, find $P(A \cap B)$
 [Ans: $\frac{15}{56}$]
- If A and B are two events such that $P(A) = \frac{2}{5}$ and $P(A \cap B) = \frac{3}{10}$, find $P(B/A)$
 [Ans: $\frac{3}{4}$]
- Two events A and B are such that $P(A) = 0.2$, $P(A' \cap B) = 0.22$, $P(A \cap B) = 0.18$. Evaluate (i) $P(A \cap B')$ (ii) $P(A/B)$ [Ans: (i) 0.02 (ii) 0.45]
- Two events A and B are such that $P(A) = \frac{1}{2}$, $P(A/B') = \frac{2}{3}$, $P(A/B) = \frac{3}{7}$, where B' is the event 'B does not occur' Find (i) $P(A \cap B)$ (ii) $P(A \cup B)$ (iii) $P(B)$ (iv) $P(B/A)$
 [Ans: (i) $\frac{3}{10}$ (ii) $\frac{9}{10}$ (iii) $\frac{7}{10}$ (iv) $\frac{3}{5}$]
- A bag contains 4 white balls, 3 black balls and 1 red ball. Two balls are picked in succession at random without replacement. Find the probability that (i) both are of the same colour (ii) at least one black ball is picked [Ans: (i) $\frac{9}{28}$ (ii) $\frac{9}{14}$]
- A box contains 7 red balls and 6 blue balls. Two balls are selected at random without replacement. Find the probability that (i) they are of the same colour (ii) at least one is blue [Ans: (i) $\frac{6}{13}$ (ii) $\frac{19}{26}$]
- Two boxes P and Q contain white and brown cards. P contains 6 white cards and 4 brown cards. Q contains 2 white cards and 3 brown cards. A box is selected at random and a card selected. Find the probability that;

(i) A brown card is selected (ii) box Q is selected given that the card is white

[Ans; (i) $\frac{2}{5}$, (ii) $\frac{1}{2}$]

12. Bag A contains 3 green and 2 red balls. Bag B contains 4 green and 3 red balls. If a ball is picked at random from a bag chosen at random, find the probability that a red ball is (i) picked (ii) not picked [Ans:(i) $\frac{29}{70}$ (ii) $\frac{41}{70}$]

13. Two independent events A and B are such that $P(A) = 0.40$, $P(B) = a$, $P(A \cup B) = 0.70$

Find (i) $P(A \cup B)'$ (ii) the value of a (iii) $P(A \cap B)$ (iv) $P(A \cap B')$

[Ans: (i) 0.3 (ii) 0.5 (iii) 0.2 (iv) 0.2]

14. Given that A and B are two events such that $P(A) = 0.5$, $P(B) = 0.7$ and $P(A \cup B) = 0.8$. Find (i) $P(A \cap B)$ (ii) $P(A \cap B')$ [Ans: (i) 0.4 (ii) 0.1]

15. Two events A and B are independent such that $P(A) = 0.2$ and $P(A \cup B) = 0.8$. Find (i) $P(B)$

(ii) $P(A' \cup B')$ [Ans: (i) $\frac{2}{3}$ (ii) $\frac{11}{15}$]

CHAPTER 16: PERMUTATIONS AND COMBINATIONS**Permutations**

A permutation is an ordered arrangement of a number of items

For example suppose a photographer must arrange three girls Anne (A), Bena (B) and Halima (H) in a row for a photograph. He can do this in six possible ways

ABH, AHB, BAH, BHA, HAB, HBA

Each arrangement is a possible permutation of the girls A, B and H and so there are six permutations altogether

There are four different books on a shelf. In how many ways could they be arranged in order?

Solution

If we label the books a, b, c and d for convenience, writing the arrangement in which a comes first

a b c d	a c d b	
a b d c	a d b c	ie 6 arrangements
a c b d	a d c b	

If we take book b first, there will be 6 arrangements as well; the same applies to book c and d coming first. Here there is a total of 24 arrangements of the four books

Alternatively, if we have four boxes into each of which one book can be put

Box 1	Box 2	Box 3	Box 4
Any one of 4	Any one of 3	Any one of 2	No choice

There are four ways of filling the first box and three ways of filling the second since three books are left after filling the first.

There are $4 \times 3 \times 2$ ways of filling the first three boxes and for the fourth, it is only one way since one book only is left.

Altogether they become $4 \times 3 \times 2 \times 1 = 24$ ways

Example 1

In how many ways can 3 books be arranged in order if 7 different books are available?

Box 1	Box 2	Box 3
7ways	6ways	5ways

Here the number of arrangements = $7 \times 6 \times 5 = 210$

Example 2

In how many ways can the 1st, 2nd and 3rd prizes be awarded in a race if there are 10 competitors?

Solution

The 1st prize can be awarded in 10 ways, the 2nd in 9ways and the third in 8 ways

Total number of ways = $10 \times 9 \times 8 = 720$ ways

Factorial notation

Let n be an integer, then the continued product of the 1st n natural numbers is called n factorial denoted by n! It is very important to note that $0! = 1$.

Hence $n! = n (n - 1) (n - 2) (n - 3) \dots \dots \dots 3 \times 2 \times 1$

$$5! = 5 \times 4 \times 3 \times 2 \times 1$$

Therefore the number of ways of arranging n unlike objects in a row is given by $n!$ i.e. the number of ways of arranging the letters of the word THURSDAY is $8! = 40320$ ways.

Example

Evaluate (a) $\frac{6!}{2 \times 4!}$ (b) $\frac{7!}{4! \times 2!}$

Solution

$$(a) \frac{6!}{2 \times 4!} = \frac{6 \times 5 \times 4 \times 3 \times 2 \times 1}{(2) \times 4 \times 3 \times 2 \times 1} = 15$$

$$(b) \frac{7!}{4! \times 2!} = \frac{7 \times 6 \times 5 \times 4 \times 3 \times 2 \times 1}{4 \times 3 \times 2 \times 1 \times (2 \times 1)} = 105$$

Permutations of objects selected from a group

Suppose we wish to arrange r objects chosen from n unlike objects, we usually say that the number of permutations of r objects selected from unlike objects is ${}^n P_r$

$${}^n P_r = \frac{n!}{(n-r)!}$$

Example1

In how many ways can the letters of the word MEASURING be arranged or permuted?

Solution

Number of letters = 9

So we are arranging 9 letters out of 9

$${}^9 P_9 = \frac{9!}{(9-9)!} = \frac{9!}{0!} = 9 \times 8 \times 7 \times 6 \times 5 \times 4 \times 3 \times 2 \times 1 = 362,880 \text{ ways}$$

Example2

Find the number of arrangements using any of the three letters of the word CHEMISTRY

Solution

CHEMISTRY has 9 letters, so arranging 3 letters out of 9 gives;

$${}^9 P_3 = \frac{9!}{(9-3)!} = \frac{9!}{6!} = 504 \text{ ways}$$

Example 3

Find the number of arrangements using four letters of the word SPHERICAL

Solution

SPHERICAL has 9 letters so arranging 4 letters out of 9 gives;

$${}^9 P_4 = \frac{9!}{(9-4)!} = \frac{9!}{5!} = 3024 \text{ ways}$$

Circular arrangements

With circular permutations, the relative positions of the items being arranged which is important. For example A B C D E is a different arrangement from E A B C D in a row,

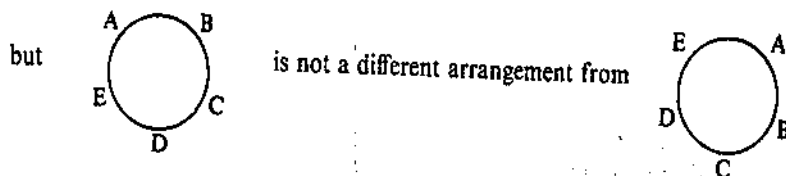

The number of arrangements of n unlike things in a circle will therefore be $(n - 1)!$ In those cases where clockwise and anticlockwise arrangements are not considered to be different, this reduces to $\frac{1}{2}(n - 1)!$

Example 1

Five girls Vivianne, Pearl, Praise, Sonia and Joan are to be seated at a circular table. In how many ways can this be done?

Solution

If one girl is fixed, there are $(5 - 1)!$ ways of arranging the remaining girls
 $= 4! = 4 \times 3 \times 2 \times 1 = 24$ ways

Example 2

Find the number of ways in which ten boys can be arranged on table.

Solutions

One of the boys must be fixed and then we arrange the remaining nine

\therefore Number of arrangements = $9! = 362880$

Example 3

Nine beads, all of different colours are to be arranged on a circular on a circular wire. Two arrangements are not considered to be different if they appear the same when the ring is turned over. How many different arrangements are possible?

Solution

When viewed from one side, these arrangements are only different in that one is a clockwise arrangement and the other is anticlockwise. For example the arrangement below;

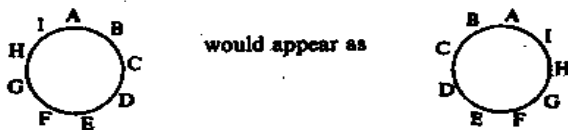

If one bead is fixed, there are $(9 - 1)!$ ways of arranging the remaining beads relative to the fixed one i.e. $8!$ Ways. But half of these arrangements will appear the same as the other half when the ring is turned over, because for every clockwise arrangement there is a similar anticlockwise arrangement.

Hence

Number of arrangements = $\frac{1}{2}(8!) = 20160$ ways

Combinations

A combination is the number of ways of selecting a group of objects from a given set of objects e.g. an A level subject combination such as HEG, PCB, PCM, MEG, etc. In making a selection from a number of items, only the contents of the group selected are important, not the order in which the items are selected i.e. GEH, GHE, HGE, EGH, EHG are all the same as HEG.

The number of possible combinations of n different objects, taken r at a time, is given by ${}^n C_r$ also

written as $\binom{n}{r}$ where ${}^n C_r = \frac{n!}{(n-r)! r!}$

Example 1

How many selections of 6 letters can be made from the 9 letters a, b, c, d, d, e, f, g, h, i?

Solution

The number of selections is ${}^n C_r$ where r is the number of things selected from a group of n .

Hence for this case $n = 9$ and $r = 6$

$${}^9 C_6 = \frac{9!}{(9-6)!6!} = \frac{9!}{3!6!} = 84$$

There are 84 selections of 6 letters which can be made from the 9 letters

Example 2

In how many ways can 4 boys be chosen from 6?

Solution

The number of selections = ${}^6 C_4 = \frac{6!}{(6-4)!4!} = \frac{6!}{2! \times 4!} = 15$

Example 3

A committee of 2 men and 3 women is to be chosen from 5 men and 4 women. How many different committees can be formed?

Solution

The two men can be selected in ${}^5 C_2 = 10$ ways

The three women can be chosen in ${}^4 C_3 = 4$ ways

The possible committees are $10 \times 4 = 40$ ways

Note that 10 is multiplied by 4 since the choice of the men and the choice of the women are independent operations

Example 4

How many different committees, each consisting of 3 boys and 2 girls can be chosen from 7 boys and 5 girls?

Solution

Number of ways of choosing 3 boys from 7 = ${}^7 C_3 = \frac{7!}{4!3!} = 35$

Number of ways of choosing 2 girls from 5 = ${}^5 C_2 = \frac{5!}{3!2!} = 10$

Number of committees which can be chosen = $35 \times 10 = 350$

Example 5

A group consists of 4 boys and 7 girls. In how many ways can a team of five be selected if it is to contain (a) no boys (b) 2 boys and 3 girls (c) at least 3 boys ?

Solution

(a) No boys are selected, so the team is chosen from the 7 girls

Number of ways of choosing 5 girls from 7 is ${}^7 C_5 = \frac{7!}{2!5!} = 21$

(b) 2 boys can be chosen from 4, in ${}^4 C_2 = 6$ ways

3 girls can be chosen from 7, in ${}^7 C_3 = 35$ ways

Number of teams = $6 \times 35 = 210$

(c) If the team is to have at least 3 boys, then there must be either 3 or 4 boys

Number of teams with 3 boys and 2 girls = ${}^4 C_3 \times {}^7 C_2 = 84$

Number of teams with 4 boys and 1 girl = ${}^4 C_4 \times {}^7 C_1 = 7$

These are mutually exclusive events, so

number of teams with at least 3 boys = $84 + 7 = 91$

Example 6

A group consists of 6 men and 5 women. If a committee of five members is to be formed. In how many ways can this be done if it must contain

- (a) At least one woman
(b) Not more than three men

Solution

(a) If the committee is to have at least one woman, then it can have 1, 2, 3, 4 or 5 women

With 1 woman and 4 men = ${}^5C_1 \times {}^6C_4 = 75$

With 2 women and 3 men = ${}^5C_2 \times {}^6C_3 = 200$

With 3 women and 2 men = ${}^5C_3 \times {}^6C_2 = 150$

With 4 women and 1 man = ${}^5C_4 \times {}^6C_1 = 30$

With 5 women and no man = ${}^5C_5 \times {}^6C_0 = 1$

Total number of ways = $75 + 200 + 150 + 30 + 1 = 456$ ways

(b)

If the committee is not to have more than 3 men, then it can have 3, 2, 1 and no man

With 3 men and 2 women = ${}^5C_2 \times {}^6C_3 = 200$

With 2 men and 3 women = ${}^5C_3 \times {}^6C_2 = 150$

With 1 man and 4 women = ${}^5C_4 \times {}^6C_1 = 30$

With no man and 5 women = ${}^5C_5 \times {}^6C_0 = 1$

Total number of ways = $200 + 150 + 30 + 1 = 381$

Trial questions

- Evaluate (a) $\frac{8!}{6!}$ (b) $\frac{9!}{3 \times 5!}$ (c) $\frac{5! \times 4!}{6!}$ [Ans: (a) 56 (b) 1008 (c) 4]
- In how many ways can a group of ten children be arranged in a line? [Ans: 10!]
- Find the number of permutations of two different letters taken from the letters A, B, C, D, E, F [Ans : 30]
- In how many ways can six books be arranged on a shelf when the books are selected from ten different books? [Ans: 151 200]
- How many code words, each consisting of five different letters, can be formed from the letters A, B, C, D, E, F, G and H? [Ans : 6720]
- In how many ways can the letters of the word median be arranged? [Ans : 720]
- How many different teams of 7 players can be chosen from 10 girls? [Ans: 120]
- Three students are to be promoted from a particular form. If five students are under consideration for promotion, in how many ways can the group to be promoted be chosen? [Ans : 10]
- A librarian has to make a selection of 5 newspapers and 7 magazines from the 8 newspapers and 9 magazines which are available. In how many ways can she make her selection? [Ans: 2016]
- Find the number of different selections from the word METHOD [Ans : 20]
- A group consists of 5 boys and 8 girls. In how many ways can a team of four be chosen, if the team contains (a) no girls (b) no more than one girl (c) at least two boys ? [Ans : (a) 5 (b) 85 (c) 365]

12. In how many ways can a committee of five people be selected from 7 men and 3 women if it must contain (a) 3 men and 2 women (b) 3 women and 2 men (c) at least 1 woman? [Ans : (a) 105 (b) 21 (c) 231]
13. In how many ways can a committee of 7 people be selected from 4 men and 6 women if the committee must have at least 4 women on it? [Ans : 100]
14. A group consists of 5 boys and 8 girls. In how many ways can a team of five be chosen if it is to contain (a) no girls (b) no boys (c) at least one boy
[Ans: (a) 1 (b) 56 (c) 1231]
15. A tennis club has to select 2 mixed double pairs from a given a group of 5 men and 4 women. In how many ways can this be done? [Ans: 120]

CHAPTER 17: RANDOM AND CONTINUOUS VARIABLES

When carrying out an experiment, variables are used to describe the event. A variable in this case can be defined as a characteristic that can assume different values. Letters of the alphabet such as X, Y, or Z can be used to represent variables. Since the variables are associated with probability, they are called random variables. Random variables may be either discrete or continuous. A discrete random variable is the variable that has values that can be counted.

DISCRETE RANDOM VARIABLES

When a variable is discrete, it is possible to specify or describe all its possible numerical values, for example;

- The number of females in a group of four students; the possible values are 0, 1, 2, 3, 4
- The number of heads obtained when a coin is thrown two times; the possible values are 0, 1, 2.
- The number of boys possible if a family plans to have three children is 0, 1, 2, 3, or 4.

Consider this situation:

By mistake, three faulty fuses are put into a box containing two good fuses. The faulty and good fuses become mixed up making a total of five fuses and indistinguishable by sight. You choose to take two fuses from the box. What is the probability that you take

- No faulty fuses
- One faulty fuse
- Two faulty fuses ?

Solution

It is possible to show the outcomes and probabilities on a tree diagram

Let event F denote faulty fuse and F' denote not faulty

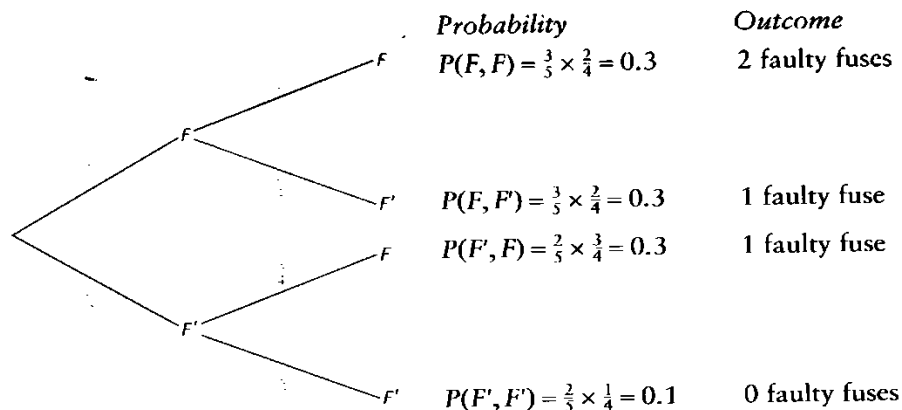

- $P(\text{no faulty fuses}) = 0.1$
- $P(\text{one faulty fuse}) = 0.3 + 0.3 = 0.6$
- $P(\text{two faulty fuses}) = 0.3$

The variable being considered here is “the number of faulty fuses” and is denoted by X.

The values that X can take are 0, 1 or 2

The probability that there are no faulty fuses, i.e. the probability that the Variable X takes the value 0, can be written $P(X=0)$, so $P(X=0) = 0.1$

Similarly $P(X=1) = 0.6$ and $P(X = 2) = 0.3$

When defining variables, the variable is usually denoted by a capital letter (X, Y, R, etc.) and a particular value that variable takes by a small letter (x, y, r etc.), so that $P(X = x)$ means “the probability that the variable X takes the value x”

The probability distribution for x can be summarized in the table below

x	0	1	2
$P(X = x)$	0.1	0.6	0.3

If the sum of the probabilities is 1, the variable is said to be random

In this example; $P(X = 0) + P(X = 1) + P(X = 2) = 0.1 + 0.6 + 0.3 = 1$, so X is a discrete random variable.

For a discrete random variable, the sum of the probabilities is 1,

$$i.e. \sum_{all\ x} P(X = x) = 1$$

$$Also\ P(X = x) \geq 0\ \text{for all values of } x$$

The function responsible for allocating probabilities, $P(X = x)$, is known as the **probability density function of X**, sometimes abbreviated to **p.d.f of X**. The probability density function can either list the probabilities individually or summarise them in a formula.

Examples

1. The discrete random variable X has the following probability distribution

x	1	2	3	4	5
$P(X = x)$	0.2	0.25	0.4	a	0.05

(a) Find the value of a

(b) Find (i) $P(1 \leq X \leq 3)$ (ii) $P(X > 2)$ (iii) $P(2 < X < 5)$ (iv) the mode

Solution

(a) using the property $\sum_{all\ x} P(X = x) = 1$;

$$0.2 + 0.25 + 0.4 + a + 0.05 = 1$$

$$0.9 + a = 1$$

$$a = 0.1$$

(b) (i) $P(1 \leq X \leq 3) = P(X=1) + P(X=2) + P(X=3)$

$$= 0.2 + 0.25 + 0.4$$

$$= 0.85$$

(ii) $P(X > 2) = P(X=3) + P(X=4) + P(X=5)$

$$= 0.4 + a + 0.05 = 0.4 + 0.1 + 0.05$$

$$= 0.55$$

(iii) $P(2 < X < 5) = P(X=3) + P(X=4)$

$$= 0.4 + a = 0.4 + 0.1$$

$$= 0.5$$

(iv) The mode is the value of x with the highest probability. The highest probability in this case is 0.4, hence the mode is 3.

2. The p.d.f of a discrete of a discrete random variable X is given by $P(X = x) = kx^2$, for $x = 0, 1, 2, 3, 4$. Given that k is a constant, find the value of k.

Solution

By drawing a table, it would help us write out the probability distribution of X.

x	0	1	2	3	4
$P(X = x)$	0	k	4k	9k	16k

since x is a random variable, $\sum_{\text{all } x} P(X = x) = 1$

$$\begin{aligned} \text{So } 0 + k + 4k + 9k + 16k &= 1 \\ 30k &= 1 \\ k &= \frac{1}{30} \end{aligned}$$

3. Suppose that a coin is tossed twice so that the sample space $S = \{HH, HT, TH, TT\}$. If X represents the number of heads that come up, find the probability function corresponding to the random variable X .

Solution

$$P(HH) = \frac{1}{4}, P(HT) = \frac{1}{4}, P(TH) = \frac{1}{4}, P(TT) = \frac{1}{4}$$

Then

$$P(X = 0) = P(TT) = \frac{1}{4}$$

$$P(X = 1) = P(HT) + P(TH) = \frac{1}{4} + \frac{1}{4} = \frac{1}{2}$$

$$P(X = 2) = P(HH) = \frac{1}{4}$$

The probability function is thus given in the table below

x	0	1	2
$P(X = x)$	$\frac{1}{4}$	$\frac{1}{2}$	$\frac{1}{4}$

EXPECTATION OF X, E(X)

$E(X)$ is read as 'E of X' and it gives an average or typical value of X , known as the expected value or expectation of X . This is comparable with the mean in the descriptive statistics.

The expectation of X (expected value or mean), written $E(X)$, is given by;

$$E(X) = \sum_{\text{all } x} xP(X = x)$$

The symbol μ , pronounced 'mew' is often used for the expectation, where $\mu = E(X)$

Examples

1. A random variable X has the following probability distribution.

x	-2	-1	0	1	2
$P(X = x)$	0.3	0.1	0.15	0.4	0.05

Find the expectation, $E(X)$

Solution

x	-2	-1	0	1	2
$P(X = x)$	0.3	0.1	0.15	0.4	0.05
$xP(X = x)$	-0.6	-0.1	0	0.4	0.1

$$\begin{aligned} E(X) &= \sum_{\text{all } x} xP(X = x) \\ &= -0.6 + -0.1 + 0 + 0.4 + 0.1 \\ &= -0.2 \end{aligned}$$

2. X is the number of heads obtained when two coins are tossed. Find the expected number of heads

Solution

$$P(X=0) = P(T, T) = \frac{1}{2} \times \frac{1}{2} = \frac{1}{4}$$

$$P(X=1) = P(T, H) + P(H, T) = \frac{1}{2} \times \frac{1}{2} + \frac{1}{2} \times \frac{1}{2} = \frac{1}{2}$$

$$P(X=2) = P(H, H) = \frac{1}{2} \times \frac{1}{2} = \frac{1}{4}$$

x	0	1	2
$P(X = x)$	$\frac{1}{4}$	$\frac{1}{2}$	$\frac{1}{4}$
$xP(X = x)$	0	$\frac{1}{2}$	$\frac{1}{2}$

$$E(X) = 0 + \frac{1}{2} + \frac{1}{2} = 1$$

3. X is the random variable 'the number of likely boys obtained' for the family that plans to have three children. Find $E(X)$

Solution

The possible outcomes are $\{BBB, BBG, BGB, BGG, GBB, GBG, GGB, GGG\}$

x	0	1	2	3
$P(X = x)$	$\frac{1}{8}$	$\frac{3}{8}$	$\frac{3}{8}$	$\frac{1}{8}$
$xP(X = x)$	0	$\frac{3}{8}$	$\frac{6}{8}$	$\frac{3}{8}$

$$E(X) = \frac{3}{8} + \frac{6}{8} + \frac{3}{8} = \frac{15}{8} = 1.875$$

VARIANCE OF X, VAR(X)

For a discrete random variable X, with $E(X) = \mu$, the variance is defined as follows;

The variance of X written $\text{Var}(X) = E(X - \mu)^2$

$$\begin{aligned} \text{Alternatively, } \text{Var}(X) &= E(X - \mu)^2 \\ &= E(X^2 - 2\mu X + \mu^2) \\ &= E(X^2) - 2\mu E(X) + E(\mu^2) \\ &= E(X^2) - 2\mu^2 + \mu^2 \\ &= E(X^2) - \mu^2 \end{aligned}$$

This format is easier to work with

Note: $\mu = E(X)$ and $\mu^2 = [E(X)]^2$

Therefore $\text{Var}(X) = E(X^2) - [E(X)]^2$

$$\text{where } E(X^2) = \sum_{\text{all } x} x^2 P(X = x)$$

$\text{Var}(X)$ is sometimes written as σ^2 (σ is pronounced as 'sigma')

$$\sigma = \sqrt{\text{Var}(X)} = \text{standard deviation of } X$$

Example 1

The random variable X has probability distribution as shown in the table;

x	1	2	3	4	5
$P(X = x)$	0.1	0.3	0.2	0.3	0.1

Find (a) $E(X)$ (b) $E(X^2)$ (c) $\text{Var}(X)$ (d) σ , the standard deviation of X

Solution

x	1	2	3	4	5
$P(X = x)$	0.1	0.3	0.2	0.3	0.1
$xP(X = x)$	0.1	0.6	0.6	1.2	0.5
x^2	1	4	9	16	25
$x^2P(X = x)$	0.1	1.2	1.8	4.8	2.5

$$(a) E(X) = 0.1 + 0.6 + 0.6 + 1.2 + 0.5 = 3$$

$$(b) E(X^2) = 0.1 + 1.2 + 1.8 + 4.8 + 2.5 = 10.4$$

$$(c) \text{Var}(X) = E(X^2) - [E(X)]^2$$

$$= 10.4 - 3^2 = 10.4 - 9$$

$$= 1.4$$

$$(d) \sigma = \sqrt{\text{Var}(X)}$$

$$= \sqrt{1.4} = 1.18 \text{ (2 d.p.)}$$

Example 2

The discrete random variable X has p.d.f $P(X=x)$ for $x=1, 2, 3$.

x	1	2	3
$P(X = x)$	0.2	0.3	0.5

Find (a) $E(X)$ (b) $E(X^2)$ (c) $\text{Var}(X)$ (d) standard deviation

Solution

x	1	2	3
$P(X = x)$	0.2	0.3	0.5
$xP(X = x)$	0.2	0.6	1.5
x^2	1	4	9
$x^2P(X = x)$	0.2	1.2	4.5

$$(a) E(X) = 0.2 + 0.6 + 1.5 = 2.3$$

$$(b) E(X^2) = 0.2 + 1.2 + 4.5 = 5.9$$

$$(c) \text{Var}(X) = E(X^2) - [E(X)]^2$$

$$= 5.9 - (2.3)^2$$

$$= 0.61$$

$$(e) \text{Standard deviation, } \sigma = \sqrt{\text{Var}(X)}$$

$$= \sqrt{0.61} = 0.781 \text{ (3d.p.)}$$

Trial questions

1. X has probability distribution as shown in the table

x	1	2	3	4	5
$P(X = x)$	0.1	0.3	A	0.2	0.05

Find (a) the value of a (b) $P(X \geq 4)$ (c) $P(X < 1)$ (d) $P(2 \leq X < 4)$

[Ans: (a) 0.35 (b) 0.25 (c) 0 (d) 0.65]

2. The probability distribution of a random variable X is as shown in the table

x	1	2	3	4	5
$P(X = x)$	0.1	0.3	Y	0.2	0.1

Find (a) the value of y (b) $E(X)$

[Ans: (a) 0.3 (b) 2.9]

3. Find the expected number of heads when two fair coins are tossed [Ans: 1]
4. The discrete random X has p.d.f $P(X = x) = kx$ for $x = 1, 2, 3, 4, 5$ where k is constant. Find $E(X)$. [Ans: $\frac{11}{3}$]
5. The discrete random variable X has a p.d.f ;
 $P(X=0)= 0.05, P(X=1)=0.45, P(X=2)=0.5$. Find (a) $E(X)$ (b) $E(X^2)$ [Ans: (a) 1.45 (b) 2.45]
6. Find Var (X) for each of the following probability distributions

(a)

x	-3	-2	0	2	3
$P(X = x)$	0.3	0.3	0.2	0.1	0.1

(b)

x	1	3	5	7	9
$P(X = x)$	1/6	1/4	1/6	1/4	1/6

(c)

x	0	2	5	6
$P(X = x)$	0.11	0.35	0.46	0.08

[Ans: (a) 4.2 (b) $22/3$ (c) 3.67]

7. X is a random variable 'the number on the biased die' and the p.d.f of X is as shown

x	1	2	3	4	5	6
$P(X = x)$	1/6	1/6	1/5	y	1/5	1/6

Find (a) the value of y (b) $E(X)$ (c) $E(X^2)$ (d) Var (X)

[Ans: (a) 1/10 (b) 3.5 (c) 15.233 (d) 0.9833]

8. A discrete random variable X can take only the values 0, 1, 2 or 3, and its probability distribution is given by $P(X=0) = k, P(X=1) = 3k, P(X=2) = 4k, P(X=3) = 5k$, where k is a constant. Find (a) the value of k (b) the mean and variance of X [Ans: (a) 1/13 (b) 2, 12/13]

CONTINUOUS RANDOM VARIABLES

A continuous random variable is one which has a continuous or uncountable domain e.g.

- The mass, in grams, of a bag of sugar packaged by a particular machine
- The time taken in minutes, to perform a task
- The height, in minutes, of a five year old girl
- The lifetime, in hours of a 100-watt light bulb
- The amounts of rainfall in a certain city

Probability density function (P.d.f)

A continuous random variable X is given by its probability distribution function(P.d.f), which is specified for the range of values for which x is valid. The probabilities are given by the area under the curve. It is denoted by $f(x)$

Properties of the probability density function

1. It is non-negative i.e. $f(x) \geq 0$ for x
2. For a continuous random variable X , with a p.d.f $f(x)$ valid over the range $a \leq x \leq b$
(a)

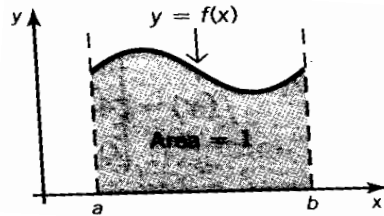

$$\int_a^b f(x) dx = 1$$

(b) for $a \leq x_1 \leq x_2 \leq b$

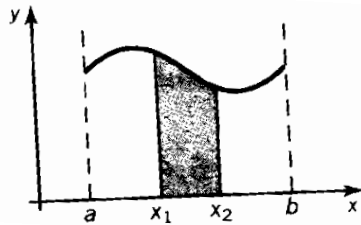

$$P(x_1 \leq X \leq x_2) = \int_{x_1}^{x_2} f(x) dx$$

Example 1

A continuous random variable has a p.d.f $f(x) = kx^2$ for $0 \leq x \leq 4$, find

- (a) The value of the constant k
- (b) $P(1 \leq X \leq 3)$

Solution

$$(a) \int_a^b f(x) dx = 1$$

$$\int_0^4 kx^2 dx = 1$$

$$\left[\frac{kx^3}{3} \right]_0^4 = 1$$

$$\frac{64k}{3} = 1$$

$$k = \frac{3}{64}$$

$$\therefore f(x) = \frac{3}{64}x^2, 0 \leq x \leq 4$$

$$(b) P(1 \leq X \leq 3) = \int_1^3 \frac{3}{64}x^2 dx$$

$$= \frac{3}{64} \int_1^3 x^2 dx$$

$$= \frac{3}{64} \left[\frac{x^3}{3} \right]_1^3 = 1$$

$$= \frac{3}{64} \left[\frac{27}{3} - \frac{1}{3} \right]$$

$$= \frac{3}{64} \times \frac{26}{3} = 0.40625$$

$$=0.41 \text{ (2 d.p)}$$

Example 2

X is a continuous random variable, the mass, in kilograms of a substance produced per minute in an industrial process, where

$$f(x) = \begin{cases} \frac{1}{36}x(6-x) & (0 \leq x \leq 6) \\ 0 & \text{otherwise} \end{cases}$$

Find the probability that the mass is more than 5 kg

Solution

$$\begin{aligned} P(X > 5) &= \int_5^6 \frac{1}{36}x(6-x)dx \\ &= \frac{1}{36} \int_5^6 (6x - x^2)dx \\ &= \frac{1}{36} \left[3x^2 - \frac{x^3}{3} \right]_5^6 \\ &= \frac{1}{36} \left[(108 - 72) - \left(75 - \frac{125}{3} \right) \right] \\ &= \frac{1}{36} \left[36 - \frac{100}{3} \right] \\ &= \frac{1}{36} \times \frac{8}{3} \\ &= 0.074 \text{ (3 d.p)} \end{aligned}$$

Example 3

The continuous random variable X has a p.d.f $f(x)$ where;

$$f(x) = \begin{cases} k & 0 \leq x < 2 \\ k(2x - 3) & 2 \leq x \leq 3 \\ 0 & \text{otherwise} \end{cases}$$

Find

- The value of the constant k
- $P(X \leq 1)$
- $P(X \geq 2.5)$
- $P(1 \leq X \leq 2.3)$

Solution

$$(a) \int_{\text{all } x} f(x)dx = 1$$

$$\int_0^2 k dx + \int_2^3 k(2x - 3) = 1$$

$$[kx]_0^2 + k[x^2 - 3x]_2^3 = 1$$

$$k(2 - 0) + k[(9 - 9) - (4 - 6)] = 1$$

$$2k + 2k = 1$$

$$4k = 1$$

$$k = \frac{1}{4}$$

$$\therefore f(x) = \begin{cases} \frac{1}{4} & 0 \leq x < 2 \\ \frac{1}{4}(2x - 3) & 2 \leq x \leq 3 \\ 0 & \text{otherwise} \end{cases}$$

$$\begin{aligned} (b) P(X \leq 1) &= \int_0^1 \frac{1}{4} dx \\ &= \left[\frac{x}{4} \right]_0^1 \end{aligned}$$

$$= \left(\frac{1}{4} - 0\right) = \frac{1}{4}$$

$$\begin{aligned} \text{(c) } P(X \geq 2.5) &= \int_{2.5}^3 \frac{1}{4}(2x - 3)dx \\ &= \frac{1}{4} \int_{2.5}^3 (2x - 3)dx \\ &= \frac{1}{4} [x^2 - 3x]_{2.5}^3 \\ &= \frac{1}{4} [(3^2 - 9) - (2.5^2 - 7.5)] \\ &= \frac{1}{4} \times 1.25 \\ &= 0.3125 \end{aligned}$$

$$\begin{aligned} \text{(d) } P(1 \leq X \leq 2.3) &= \int_1^{2.3} \frac{1}{4} dx + \int_2^{2.3} \frac{1}{4}(2x - 3)dx \\ &= \left[\frac{x}{4}\right]_1^{2.3} + \frac{1}{4} [x^2 - 3x]_{2.3}^2 \\ &= \left(\frac{2.3}{4} - \frac{1}{4}\right) + \frac{1}{4} [(2.3^2 - 6.9) - (2^2 - 6)] \\ &= \frac{1}{4} + \frac{1}{4}(-1.61 + 2) \\ &= 0.25 + 0.25(0.39) \\ &= 0.25 + 0.0975 \\ &= 0.3475 \end{aligned}$$

EXPECTATION OF X, E(X)

For a continuous random variable with a p.d.f $f(x)$

$$E(X) = \int_{\text{all } x} xf(x)dx$$

$E(X)$ is referred to as the mean or expectation of X and is often denoted μ

Example 1

The p.d.f of a continuous random variable X is given below

$$f(x) = \begin{cases} \frac{1}{9}x^2 & 0 \leq x \leq 3 \\ 0 & \text{otherwise} \end{cases}$$

Find

- μ , the mean of X
- $P(X < \mu)$

Solution

$$\text{(a) } \mu = E(X)$$

$$\begin{aligned} &= \int_{\text{all } x} xf(x)dx \\ &= \int_0^3 x \times \frac{1}{9}x^2 dx \end{aligned}$$

$$\begin{aligned}
 &= \frac{1}{9} \int_0^3 x^3 dx \\
 &= \frac{1}{9} \left[\frac{x^4}{4} \right]_0^3 \\
 &= \frac{1}{9} \left(\frac{81}{4} - 0 \right) \\
 &= \frac{1}{9} \times \frac{81}{4} = 2.25
 \end{aligned}$$

$$(b) \quad P(X < \mu) = P(X < 2.25)$$

$$\begin{aligned}
 &= \int_0^{2.25} \frac{1}{9} x^2 dx \\
 &= \frac{1}{9} \left[\frac{x^3}{3} \right]_0^{2.25} \\
 &= \frac{1}{9} \left(\frac{(2.25)^3}{3} - (0) \right) \\
 &= 0.42
 \end{aligned}$$

Example 2

A teacher of young children is thinking of asking her class to guess her height in metres. The teacher considers that the height guessed by a randomly selected child can be modeled by the random variable X with probability density function

$$f(x) = \begin{cases} \frac{3}{16}(4x - x^2) & 0 \leq x \leq 2 \\ 0 & \text{otherwise} \end{cases}$$

Using this model,

(a) Find $P(X < 1)$

(b) Show that $E(X) = 1.25$

Solution

$$\begin{aligned}
 (a) \quad P(X < 1) &= \int_0^1 f(x) dx \\
 &= \int_0^1 \frac{3}{16} (4x - x^2) dx \\
 &= \frac{3}{16} \left[2x^2 - \frac{x^3}{3} \right]_0^1 \\
 &= \frac{3}{16} \times \left(2 - \frac{1}{3} - (0) \right) \\
 &= \frac{3}{16} \times \frac{5}{3} = \frac{5}{16} \\
 &= 0.3125
 \end{aligned}$$

$$\begin{aligned}
 (b) \quad E(X) &= \int_{\text{all } x} xf(x) dx \\
 &= \frac{3}{16} \int_0^2 (4x^2 - x^3) dx \\
 &= \frac{3}{16} \left[\frac{4x^3}{3} - \frac{x^4}{4} \right]_0^2
 \end{aligned}$$

$$\begin{aligned}
&= \frac{3}{16} \left(\frac{4(2)^3}{3} - \frac{(2)^4}{4} - (0) \right) \\
&= \frac{3}{16} \left(\frac{32}{3} - \frac{16}{4} \right) \\
&= \frac{3}{16} \times \frac{32}{3} - \frac{3}{16} \times \frac{16}{4} \\
&= 2 - \frac{3}{4} = \frac{5}{4} \\
&= 1.25
\end{aligned}$$

Example 3

A continuous random variable X has a p.d.f $f(x)$ where

$$f(x) = \begin{cases} 0.25x & 0 \leq x < 2 \\ 1 - 0.25x & 2 \leq x \leq 4 \\ 0 & \text{otherwise} \end{cases}$$

Find $E(X)$

Solution

$$\begin{aligned}
E(X) &= \int_{\text{all } x} xf(x)dx \\
&= \int_0^2 x \times 0.25x \, dx + \int_2^4 x \times (1 - 0.25x) \, dx \\
&= 0.25 \int_0^2 x^2 \, dx + \int_2^4 (x - 0.25x^2) \, dx \\
&= 0.25 \left[\frac{x^3}{3} \right]_0^2 + \left[\frac{x^2}{2} - 0.25 \frac{x^3}{3} \right]_2^4 \\
&= \frac{2}{3} + \left(8 - \frac{16}{3} - \left(2 - \frac{2}{3} \right) \right) \\
&= 2
\end{aligned}$$

THE EXPECTATION OF ANY FUNCTION OF X

If $g(x)$ is any function of the continuous random variable, X , having a p.d.f $f(x)$ then

$$E(g(x)) = \int_{\text{all } x} g(x)f(x)dx$$

$$\text{In particular} \quad E(X^2) = \int_{\text{all } x} x^2 f(x)dx$$

Example

The continuous random variable X has a p.d.f $f(x)$ where

$$f(x) = \begin{cases} \frac{1}{20}(x + 3) & 0 \leq x \leq 4 \\ 0 & \text{otherwise} \end{cases}$$

Find (a) $E(X)$ (b) $E(X^2)$

Solution

$$\begin{aligned}
\text{(a) } E(X) &= \int_{\text{all } x} xf(x)dx \\
&= \int_0^4 \frac{1}{20} x(x + 3) \, dx \\
&= \frac{1}{20} \int_0^4 (x^2 + 3x) \, dx
\end{aligned}$$

$$= \frac{1}{20} \left[\frac{x^3}{3} + \frac{3x^2}{2} \right]_0^4$$

$$= 2.3$$

$$(b) E(X^2) = \int_{\text{all } x} x^2 f(x) dx$$

$$= \frac{1}{20} \int_0^4 x^2(x+3) dx$$

$$= \frac{1}{20} \int_0^4 (x^3 + 3x^2) dx$$

$$= \frac{1}{20} \left[\frac{x^4}{4} + x^3 \right]_0^4$$

$$= 6.4$$

Note: $E(X^2)$ is an important value which is needed when calculating the variance of X .

VARIANCE OF X, VAR (X)

If X is a continuous random variable with p.d.f $f(x)$, then

$$\text{Var}(X) = \int_{\text{all } x} x^2 f(x) dx - \mu^2$$

$$\text{where } \mu = E(X) = \int_{\text{all } x} x f(x) dx$$

The standard deviation of X is often written as σ , so $\sigma = \sqrt{\text{Var}(X)}$

Example 1

The continuous random variable X has p.d.f $f(x)$ where $f(x) = \frac{1}{8}x$, $0 \leq x \leq 4$. Find

- (a) $E(X)$
- (b) $E(X^2)$
- (c) $\text{Var}(X)$
- (d) σ , the standard deviation of X

Solution

$$(a) E(X) = \int_{\text{all } x} x f(x) dx$$

$$= \int_0^4 \frac{1}{8} x^2 dx$$

$$= \frac{1}{8} \left[\frac{x^3}{3} \right]_0^4$$

$$= 2.7$$

$$\begin{aligned}
 (b) \quad E(X^2) &= \int_{\text{all } x} x^2 f(x) dx \\
 &= \int_0^4 \frac{1}{8} x^3 dx \\
 &= \frac{1}{8} \left[\frac{x^4}{4} \right]_0^4 \\
 &= \frac{1}{8} (64) \\
 &= 8
 \end{aligned}$$

$$\begin{aligned}
 (c) \quad \text{Var}(X) &= E(X^2) - [E(X)]^2 \\
 &= 8 - (2.7)^2 \\
 &= 0.89 \text{ (2 d.p)}
 \end{aligned}$$

$$\begin{aligned}
 (d) \quad \sigma &= \sqrt{\text{Var}(X)} \\
 &= \sqrt{0.89} \\
 &= 0.94
 \end{aligned}$$

Example 2

As an experiment, a temporary roundabout is installed at the crossroads. The time, X minutes, which vehicles have to wait before entering the roundabout has a probability density function

$$f(x) = \begin{cases} 0.8 - 0.32x & 0 \leq x \leq 2.5 \\ 0 & \text{otherwise} \end{cases}$$

Find the mean and standard deviation of X

Solution

$$\begin{aligned}
 E(X) &= \int_{\text{all } x} x f(x) dx \\
 &= \int_0^{2.5} (0.8x - 0.32x^2) dx \\
 &= \left[0.8 \frac{x^2}{2} - 0.32 \frac{x^3}{3} \right]_0^{2.5} \\
 &= 0.8333 \text{ minutes}
 \end{aligned}$$

$$\begin{aligned}
 E(X^2) &= \int_{\text{all } x} x^2 f(x) dx \\
 &= \int_0^{2.5} (0.8x^2 - 0.32x^3) dx \\
 &= \left[0.8 \frac{x^3}{3} - 0.32 \frac{x^4}{4} \right]_0^{2.5} \\
 &= 1.041 \\
 \text{Var}(X) &= E(X^2) - [E(X)]^2 \\
 &= 1.041 - 0.8333^2 \\
 &= 0.347
 \end{aligned}$$

Standard deviation of $X = \sqrt{0.347} = 0.59$

Trial questions

1. The continuous random variable X has a p.d.f $f(x)$ where $f(x) = kx^2$ for $0 \leq x \leq 2$

(a) Find the value of the constant k

(b) Find $P(X \geq 1)$

(c) Find $P(0.5 \leq X \leq 1.5)$

[Ans: (a) $3/8$ (b) $7/8$ (c) $13/32$]

2. A continuous random variable has a p.d.f $f(x)$ where $f(x) = kx, 0 \leq x \leq 4$

(a) Find the value of the constant k

(b) Find $P(1 \leq x \leq 2.5)$

[Ans: (a) 0.125 (b) 0.328]

3. Find $E(X)$ for each of the following continuous random variables

(a) $f(x) = \frac{3}{4}(x^2 + 1), 0 \leq x \leq 1$

(b) $f(x) = \frac{3}{4}x(2 - x), 0 \leq x \leq 2$

(c) $f(x) = kx^3, 0 \leq x \leq 2$

(d) $f(x) = \begin{cases} \frac{3}{8} & \frac{2}{3} \leq x \leq 2 \\ \frac{3}{32}x(4 - x) & 2 \leq x \leq 4 \\ 0 & \text{otherwise} \end{cases}$

[Ans: (a) $9/16$ (b) 1 (c) 1.6 (d) 2.042]

4. A random variable X has a probability density function f given by

$$f(x) = \begin{cases} kx(5 - x) & 0 \leq x \leq 5 \\ 0 & \text{otherwise} \end{cases}$$

Show that $k = \frac{6}{125}$ and find the mean of X [Ans: 2.5]

5. For each of the questions (a) to (d), find

(i) $E(X)$ (ii) $E(X^2)$ (iii) $\text{Var}(X)$ (iv) the standard deviation of x

(a) $f(x) = \frac{3}{8}x^2; 0 \leq x \leq 2$

(b) $f(x) = \frac{1}{4}(4 - x); 1 \leq x \leq 3$

(c) $f(x) = 4x^3; 0 \leq x \leq 1$

(d) $f(x) = \begin{cases} \frac{1}{4} & 0 \leq x \leq 2 \\ \frac{1}{4}(2x - 3) & 2 \leq x \leq 3 \\ 0 & \text{otherwise} \end{cases}$

[Ans: (a) (i) 1.5 (ii) 2.4 (iii) 1.5 (iv) 0.387

(b) (i) $11/6$ (ii) $11/3$ (iii) $11/36$ (iv) 0.553

(c) (i) $4/5$ (ii) $2/3$ (iii) $2/75$ (iv) 0.163

(d) (i) $1\frac{19}{24}$ (ii) $2\frac{1}{24}$ (iii) $479/576$ (iv) 0.912]

CHAPTER 18: BINOMIAL DISTRIBUTION

There are some probability situations that may result into only two outcomes, or even be reduced to only two. Such situations may include:

- i) when a baby is born, it may be either male or female
- ii) in a final football match, a team either wins or loses.

Other situations that are reduced to only two possible outcomes may include:

- i) a person taking a Pioneer bus may arrive either on time or not on time.
- ii) a company producing items that are either defective or not defective
- iii) a drug administered to a patient may be either effective or ineffective.

All the above mentioned situations are called binomial or Bernoulli experiments and the outcomes of a binomial experiment are classified as successes or failures.

For a situation to be described using a binomial model,

- a finite number, n , trials are carried out
- the trials are independent
- the outcome of each trial is deemed either a success or a failure
- the probability, p , of a successful outcome is the same for each trial

The discrete random variable, X , is **the number of successful outcomes in n trials**.

If the above conditions are satisfied, X is said to follow a binomial distribution. This is written

$$X \sim B(n, p)$$

Note: The number of trials, n , and the probability of success, p , are both needed to describe the distribution completely. They are known as the parameters of the binomial distribution.

Writing $P(\text{failure})$ as q where $q = 1 - p$

If $X \sim B(n, p)$, the probability of obtaining r successes in n trials is $P(X = r)$ where;

$$P(X = r) = {}^n C_r p^r q^{n-r} \text{ for } r = 0, 1, 2, 3, \dots, n$$

Example 1

A coin is tossed three times. Find the probability of getting exactly three heads

Solution 1

The problem can be solved by looking at the sample space, there are three ways of getting two heads i.e. {HHH, HHT, HTH, THH, TTH, THT, HTT, TTT }

The answer is $\frac{3}{8} = 0.375$

Solution 2

Looking at the problem above from the stand point of a binomial experiment, one can show that it meets the four requirements i.e.

1. there are only two outcomes for each trial, head or tail
2. there is a fixed number of trials, three
3. the outcomes are independent of each other (the outcome of one toss in no way affects the outcome of another toss)
4. the probability of success (heads) is $\frac{1}{2}$ in each case.

In this case ; $n = 3$, $X = 2$, $p = \frac{1}{2}$, $q = \frac{1}{2}$

Hence substituting in the formula gives;

$$P(2 \text{ heads}) = {}^3 C_2 \left(\frac{1}{2}\right)^2 \left(\frac{1}{2}\right)^1 = \frac{3}{8} = 0.375$$

Which is the same answer obtained by using the sample space

Example 2

In a particular population, 10% of the people have blood type B. If three people are selected at random from the population, what is the probability that exactly two of them have blood type B?

Solution

When three people are selected, $n = 3$, $p = 0.1$, $q = 0.9$

X is the number of outcomes in 3 trials, so $X \sim B(3, 0.1)$

$$\begin{aligned} P(X = r) &= {}^n C_r p^r q^{n-r} \\ P(X = 2) &= {}^3 C_2 0.1^2 0.9^1 \\ &= 0.072 \end{aligned}$$

Example 3

A biased coin is tossed 6 times. The probability of heads on any toss is 0.3. Let X denote the number of heads that come up.

Calculate:

- (i) $P(X = 2)$
- (ii) $P(X = 3)$
- (iii) $P(1 < X \leq 5)$

Solution

- (i) if we call heads a success, then X has a binomial distribution with parameters $n = 6$ and $p = 0.3$

$$\begin{aligned} P(X = 2) &= {}^6 C_2 (0.3)^2 (0.7)^4 \\ &= 0.324135 \end{aligned}$$

$$\begin{aligned} \text{(ii) } P(X = 3) &= {}^6 C_3 (0.3)^3 (0.7)^3 \\ &= 0.18522 \end{aligned}$$

$$\begin{aligned} \text{(iii) } P(1 < X \leq 5) &= P(X=2) + P(X=3) + P(X=4) + P(X=5) \\ &= 0.324 + 0.185 + 0.059 + 0.01 \\ &= 0.578 \end{aligned}$$

Example 4

A die is tossed three times. If X is the number of fives obtained. Find the probability that

- (i) No fives turn up
- (ii) 1 five
- (iii) 3 fives

Solution

$$X \sim B(n, p)$$

$$n = 3, p = 1/6, q = 5/6$$

$$\text{(i) } P(X = 0) = {}^3 C_0 \left(\frac{1}{6}\right)^0 \left(\frac{5}{6}\right)^3 = \frac{125}{216} = 0.5787$$

$$\text{(ii) } P(X = 1) = {}^3 C_1 \left(\frac{1}{6}\right)^1 \left(\frac{5}{6}\right)^2 = \frac{75}{216} = 0.34722$$

$$\text{(iii) } P(X = 3) = {}^3 C_3 \left(\frac{1}{6}\right)^3 \left(\frac{5}{6}\right)^0 = \frac{1}{216} = 0.0046296$$

Example 5

Hospital records show that of patients suffering from a certain disease, 75% die of it. What is the probability that of 6 randomly selected patients, 4 will recover?

Solution

Let X = number who will cover

$$X \sim B(n, p)$$

$n = 6$, $p = 0.25$ and $q = 0.75$ (failure i.e. they die)

$$\begin{aligned} P(X = 4) &= {}^6C_4(0.25)^4(0.75)^2 \\ &= 15 \times 0.0021973 \\ &= 0.0329595 \end{aligned}$$

Example 6

In the old days, there was a probability of 0.8 of success in any attempt to make a telephone call (this depended on the importance of the person making the call or the operator's curiosity).

Calculate the probability of having 7 successes in 10 attempts.

Solution

Probability of success, $p = 0.8$, so $q = 0.2$

X = success in getting through

$$n = 10, r = 7$$

$$P(X = r) = {}^nC_r p^r q^{n-r}$$

$$\begin{aligned} P(X = 7) &= {}^{10}C_7(0.8)^7(0.2)^3 \\ &= 0.20133 \end{aligned}$$

Example 7

A blind folded marks man finds that on average, he hits the target 4 times out of 5. If he fires 4 shots. What is the probability of

- (a) more than two hits
(b) at least three misses

Solution

$$n = 4, p = \frac{4}{5} = 0.8 \text{ and } q = 0.2$$

X = number of hits

$$\begin{aligned} \text{(a) } P(X > 2) &= P(X=3) + P(X=4) \\ &= {}^4C_3(0.8)^3(0.2)^1 + {}^4C_4(0.8)^4(0.2)^0 \\ &= 0.8192 \end{aligned}$$

(b) At least 3 misses means 3 misses or more

3 misses means one hit, and 4 misses means 0 hit

$$\begin{aligned} P(\text{at least 3 misses}) &= P(X=1) + P(X=0) \\ &= {}^4C_1(0.8)^1(0.2)^3 + {}^4C_0(0.8)^0(0.2)^4 \\ &= 0.0272 \end{aligned}$$

Example 8

A manufacturer of metal pistons finds that on average, 12% of his pistons are rejected because they are either oversize or undersize. What is the probability that a batch of 10 pistons will contain;

- (a) Not more than two rejects
(b) At least two rejects

Solution

Let X = number of rejects, in this case “success” means rejection

$$n = 10, p = 0.12 \text{ and } q = 0.88$$

(a) Not more than two rejects means two rejects or less i.e. $X \leq 2$

$$\begin{aligned} P(X \leq 2) &= P(X = 0) + P(X = 1) + P(X = 2) \\ &= {}^{10}C_0(0.12)^0(0.88)^{10} + {}^{10}C_1(0.12)^1(0.88)^9 + {}^{10}C_2(0.12)^2(0.88)^8 \\ &= 0.2785 + 0.37977 + 0.23304 \\ &= 0.89131 \end{aligned}$$

(b) At least two rejects means two rejects or more i.e. $X \geq 2$

We would work out all the cases for $X = 2, 3, 4, \dots, 10$. But it would be hectic. It is much easier using the tables or proceed as follows;

$$\begin{aligned} \text{Probability of at least 2 rejects} &= P(X=2) + P(X=3) + \dots + P(X=10) \\ &= 1 - P(X \leq 1) \\ &= 1 - [P(X = 0) + P(X = 1)] \\ &= 1 - [0.2785 + 0.37977] \\ &= 0.34173 \end{aligned}$$

Example 9

If a student randomly guesses at five multiple-choice questions, find the probability that the student gets exactly three correct answers if each question has five possible choices.

Solution

$n = 5, X = 3$ and $p = \frac{1}{5} = 0.2$ since there is one chance in five of guessing a correct answer
 $q = 0.8$

$$\begin{aligned} P(X = 3) &= {}^5C_3(0.2)^3(0.8)^2 \\ &= 0.05 \end{aligned}$$

Example 10

A certain survey found out that 30% of teenage consumers receive their spending money from part-time jobs. If five teenagers are selected at random, find the probability that at least three of them will have part-time jobs.

Solution

Let X = number having part-time jobs

$$n = 5, p = 0.3, q = 0.7$$

$$\begin{aligned} P(X \geq 3) &= P(X=3) + P(X=4) + P(X=5) \\ &= {}^5C_3(0.3)^3(0.7)^2 + {}^5C_4(0.3)^4(0.7)^1 + {}^5C_5(0.3)^5(0.7)^0 \\ &= 0.132 + 0.028 + 0.002 \\ &= 0.162 \end{aligned}$$

Example 11

The probability that a pen drawn at random from a box of pens is 0.1. If a sample of 6 pens is taken, find the probability that it will contain

- (i) No defective pens
- (ii) 5 or 6 defective pens

(iii) Less than 3 defective pens

Solution

$$n = 6, p = 0.1$$

let X = number of defective pens

$$(i) P(X = 0) = {}^6C_0(0.1)^0(0.9)^6 = 0.5314$$

$$(ii) P(X=5) + P(X=6) \\ = {}^6C_5(0.1)^5(0.9)^1 + {}^6C_6(0.1)^6(0.9)^0 \\ = 0.000054 + 0.000001 \\ = 0.000055$$

$$(iii) P(X < 3) = P(X \leq 2) \\ P(X \leq 2) = P(X=0) + P(X=1) + P(X=2) \\ = {}^6C_0(0.1)^0(0.9)^6 + {}^6C_1(0.1)^1(0.9)^5 + {}^6C_2(0.1)^2(0.9)^3 \\ = 0.5314 + 0.3543 + 0.0984 \\ = 0.9841$$

Note that some of the above probabilities can be obtained using the tables. The value of n is located from the table and its corresponding p (probability of success noted). The probability can be read off from the table for $r = 0, 1, 2, 3, \dots, n$

Using the above example, obtain $P(X = 0)$

Solution

$$n = 6, p = 0.1$$

Table

B (n, p) individual terms

n	r	Probability of success									
		0.01	0.05	0.1	0.15	0.2	0.25	0.3	0.35	0.5
6	0			0.5314							
	1			0.3543							
	2			0.0984							
	3			0.0146							
	4			0.0012							
	5			0.0001							
	6										

From the table $P(X=0) = 0.5314$ obtained by reading $n = 6, n = 6$ and $p = 0.1$

Then $P(X=1) = 0.3543$

$$P(X=2) = 0.0984$$

Example 12

A multiple choice question paper has 15 questions, each with 4 possible answers of which only one is the correct answer. Determine the probability that by mere guessing, one gets

- (i) Exactly five correct answers
- (ii) Five incorrect answers

Solution

$$n = 15, p = \frac{1}{4} = 0.25$$

let X = number of correct answers

(a) $P(X=5)$

From the table when $n = 15, r = 5, p = 0.25$

$$P(X = 5) = 0.1651$$

(b) $P(\text{five incorrect answers}) = P(\text{ten correct answers})$
 $= P(X=10)$

Using the tables $n = 15, r = 10, p = 0.25$

$$P(X = 10) = 0.0007$$

$$P(\text{five incorrect answers}) = 0.0007$$

Mean, Variance and standard deviation for the binomial distribution

The mean, variance and standard deviation of a variable that has the binomial distribution can be found by using the formulas

$$\text{Mean, } \mu = np$$

$$\text{Variance, } \sigma^2 = npq$$

$$\text{Standard deviation, } \sigma = \sqrt{\text{Var}(X)} = \sqrt{npq}$$

Example 1

A coin is tossed four times. Find the mean, Variance and standard deviation of the number of heads that will be obtained

Solution

$$n = 4, p = 1/2, q = 1/2$$

$$\text{Mean} = np = 4 \times \frac{1}{2} = 2$$

$$\text{Variance} = npq = 4 \times \frac{1}{2} \times \frac{1}{2} = 1$$

$$\text{Standard deviation} = \sqrt{1} = 1$$

Example 1

In Makerere university, it is known that $\frac{1}{3}$ of the students play volleyball. In a sample of 12 students, what is the expected value and standard deviation of the number of volley ballers?

Solution

Let X = number of volley ballers

$$X \sim B(n, p)$$

$$n = 12, p = \frac{1}{3}, q = \frac{2}{3}$$

$$\text{Mean} = np = 12 \times \frac{1}{3} = 4$$

$$\text{Standard deviation} = \sqrt{12 \times \frac{1}{3} \times \frac{2}{3}}$$

$$= 1.633$$

Trial questions

1. 30% of students in a school travel to school by bus. From a sample of ten students chosen at random, find the probability that
 - (a) Only three travel by bus
 - (b) Less than half travel by bus[Ans: (a)0.267 (b)0.850]
2. In a survey on washing powder, it is found that the probability that a shopper chooses Omo is 0.25. Find the probability that in a random sample of nine shoppers
 - (a) Exactly three choose Omo
 - (b) More than seven choose Omo[Ans: (a) 0.234 (b)0.000107]
3. The random variable X is $B(6, 0.42)$. Find
 - (a) $P(X = 6)$ (b) $P(X = 4)$ (c) $P(X \leq 2)$[Ans: (a) 0.00549 (b) 0.157 (c) 0.503]
4. An unbiased die is thrown seven times. Find the probability of throwing at least 5 sixes
[Ans: 0.002]
5. A fair coin is tossed six times. Find the probability of throwing at least four heads.
[Ans: 0.344]
6. In a test there are ten multiple choice questions. For each question, there is a choice of four answers, only one of which is correct. A student guesses each of the answers
 - (a) Find the probability that he gets more than seven correct
 - (b) If he needs to obtain over half marks to pass and each question carries equal weight, find the probability that he passes the test[Ans: (a)0.000416 (b)0.0197]
7. The probability that it will be a fine day is 0.4. Find the
 - (a) Expected number of fine days in a week
 - (b) The standard deviation in the week[Ans: (a) 2.8 (b)1.3]

CHAPTER 19: NORMAL DISTRIBUTION

The normal distribution is one of the most important distributions in statistics. Many measured quantities in natural sciences follow a normal distribution and under certain circumstances, it is also a useful approximation to the binomial distribution

The normal variable X is continuous and its probability density function $f(x)$ depends on its mean μ and the standard deviation σ , where

$$f(x) = \frac{1}{\sigma\sqrt{2\pi}} e^{-(x-\mu)^2/2\sigma^2}; \quad -\infty \leq x \leq \infty$$

This is very complicated and has been included just for reference. You **would not** be expected to remember it

To describe the distribution

$$\text{Write } X \sim N(\mu, \sigma^2)$$

Note that the description gives the variance σ^2 , rather than the standard deviation σ

The normal distribution curve has the following features

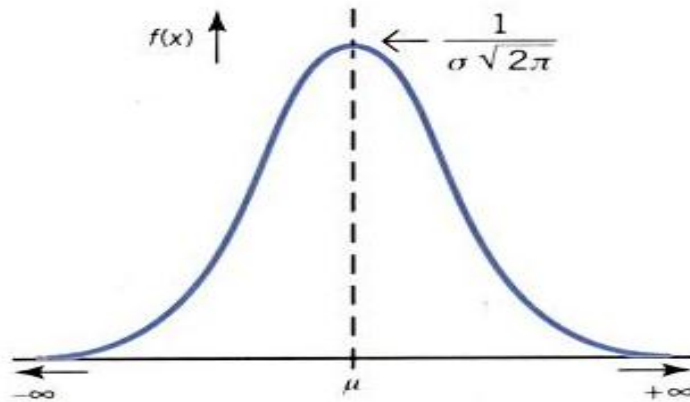

- It is bell shaped
- It is symmetrical about μ
- It extends from $-\infty$ to ∞
- The total area under the curve is 1
- The maximum value of $f(x)$ is $\frac{1}{\sigma\sqrt{2\pi}}$

Finding probabilities

The probability that X lies between a and b is written $P(a < X < b)$. To find the probabilities, you need to find the area under the normal curve between a and b

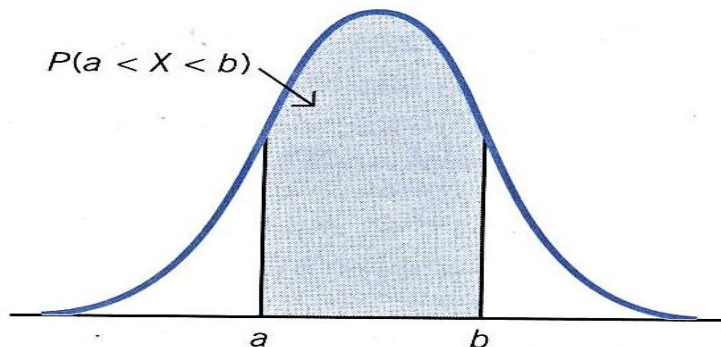

One way of finding areas is to integrate but since the normal function is complicated and very difficult to integrate, tables are used instead.

The standard normal tables

In order to use the same set of tables for all possible values of μ , and σ^2 , the variable X is standardized so that the mean is 0 and the standard deviation is 1. Note that the variance is the square of the standard deviation hence the variance is also 1. This standardized normal variable is called Z and $Z \sim N(0, 1)$

Using the standard normal tables for any random variable

Standardize X , where $X \sim N(\mu, \sigma^2)$

- Subtract the mean μ
- Then divide by the standard deviation, σ , to obtain ;

$$Z = \frac{X - \mu}{\sigma} \quad \text{where } Z \sim N(0, 1)$$

Example 1

The length of metal strips produced by a machine are normally distributed with mean length of 150 cm and standard deviation of 10 cm. Find the probability that the length of a randomly selected strip is shorter than 165 cm.

Solution

X is the length in centimeters of a metal strip

$$\mu = 150, \quad \sigma = 10, \quad X \sim N(150, 10^2)$$

You need to find the probability that the length is shorter than 165 cm i.e. $P(X < 165)$

To be able to use the standard normal tables, standardize the X - variable by subtracting the mean, 150, and then dividing by the standard deviation, 10.

$$X \text{ becomes } \frac{X-150}{10} = Z$$

$$\begin{aligned} P(X < 165) &= P\left(Z < \frac{165-150}{10}\right) \\ &= P(Z < 1.5) \end{aligned}$$

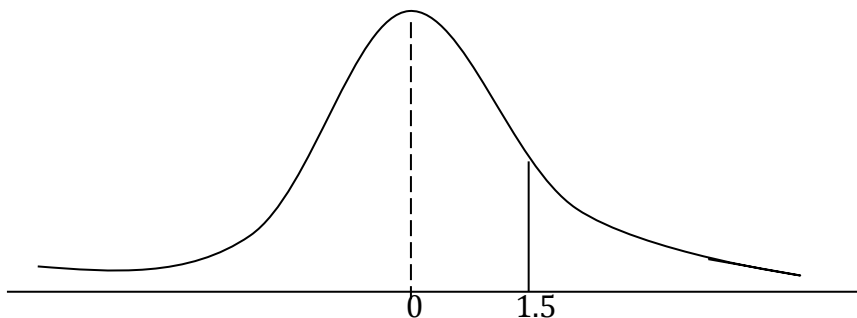

$$\begin{aligned} P(Z < 1.5) &= 0.5 + P(0 < Z < 1.5) \\ &= 0.5 + 0.4332 \\ &= 0.9332 \end{aligned}$$

Therefore the probability that the length is shorter than 165 cm is 0.9332

Example 2

The time taken by the milk man to deliver to kampale market street is normally distributed with a mean of 12 minutes and standard deviation of 2 minutes. He delivers milk every day. Estimate the number of days during the year when he takes

- (a) longer than 17 minutes
 (b) less than 10 minutes
 (c) between nine and 13 minutes

Solution

X is the time, in minutes, taken to deliver milk to market street

$$X \sim N(12, 2^2)$$

Standardizing X using $Z = \frac{X-\mu}{\sigma}$ i.e. $\frac{X-12}{2}$

$$\begin{aligned} \text{(a) } P(X > 17) &= P\left(Z > \frac{17-12}{2}\right) \\ &= P(Z > 2.5) \end{aligned}$$

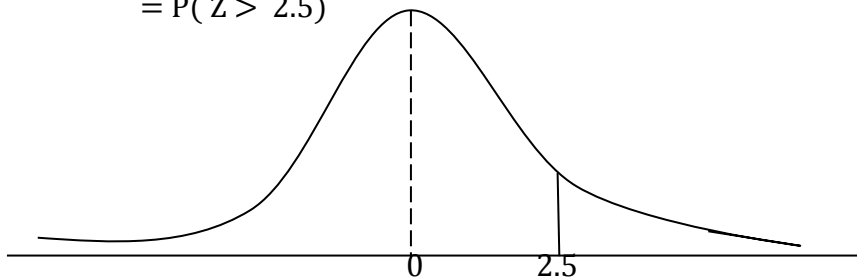

$$\begin{aligned} P(Z > 2.5) &= 0.5 - P(0 < Z < 2.5) \\ &= 0.5 - 0.4938 \\ &= 0.0062 \end{aligned}$$

To find the number of days, multiply by 365

$$365 \times 0.0062 = 2.263 \approx 2$$

On two days in the year, he takes longer than 17 minutes

$$\begin{aligned} \text{(b) } P(X < 10) &= P\left(Z < \frac{10-12}{2}\right) \\ &= P(Z < -1) \end{aligned}$$

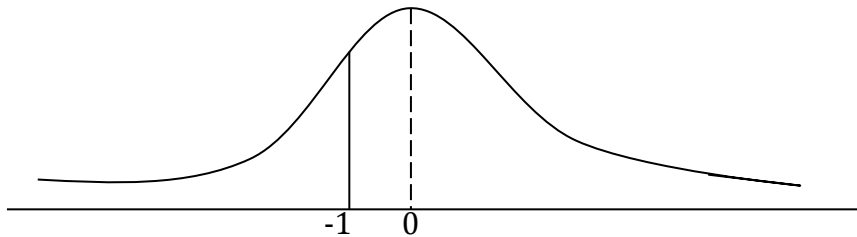

$$\begin{aligned} P(Z < -1) &= 0.5 - P(0 < Z < -1) \\ &= 0.5 - 0.3413 \\ &= 0.1587 \end{aligned}$$

$$\text{Now } 365 \times 0.1587 = 57.92 \approx 58$$

On 58 days in the year, he takes less than 10 minutes

$$\text{(c) } P(9 < X < 13) = P\left(\frac{9-12}{2} < Z < \frac{13-12}{2}\right)$$

$$= P(-1.5 < Z < 0.5)$$

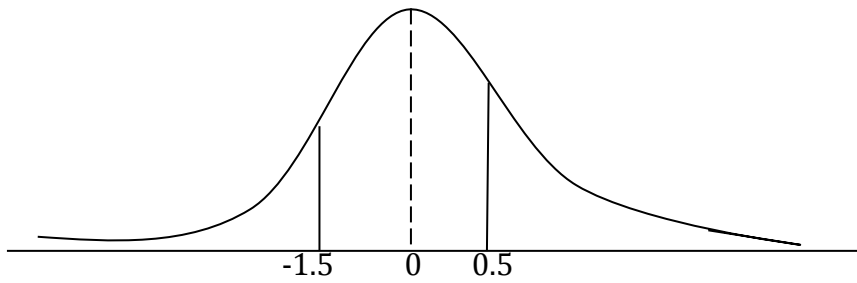

$$\begin{aligned} P(-1.5 < Z < 0.5) &= P(0 < Z < -1.5) + P(0 < Z < 0.5) \\ &= 0.1915 + 0.4332 \\ &= 0.6247 \end{aligned}$$

$$\text{Now } 365 \times 0.6247 = 228.01 \approx 228$$

On 228 days in the year, he takes between nine and 13 minutes

Example 3

A product sold in packets whose masses are normally distributed with a mean of 1.42 kg and a standard deviation of 0.025 kg.

- (a) Find the probability that the mass of a packet selected at random lies between 1.37 kg and 1.45 kg
 (b) Estimate the number of packets in an output of 5000, whose mass is less than 1.35 kg

Solution

X is the mass in kilograms of a packet

$$X \sim N(1.42, 0.025^2)$$

(a) $P(1.37 < X < 1.42)$

(b)

Standardizing using $Z = \frac{X-1.42}{0.025}$

$$P(1.37 < X < 1.42) = P\left(\frac{1.37-1.42}{0.025} < Z < \frac{1.45-1.42}{0.025}\right)$$

$$= P(-2 < Z < 1.2)$$

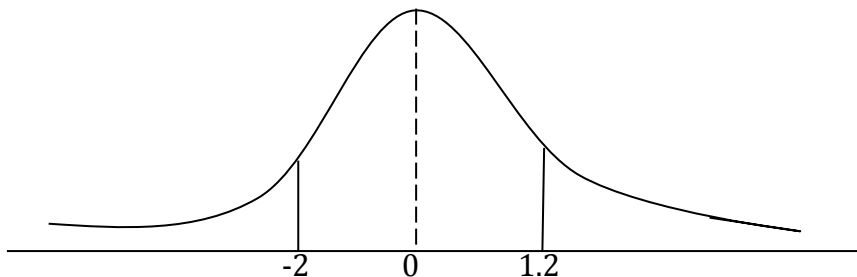

$$P(-2 < Z < 1.2) = P(0 < Z < -2) + P(0 < Z < 1.2)$$

=

$$= 0.8621$$

(c) $P(X < 1.35) = P\left(Z < \frac{1.35-1.42}{0.025}\right)$

$$= P(Z < -2.8)$$

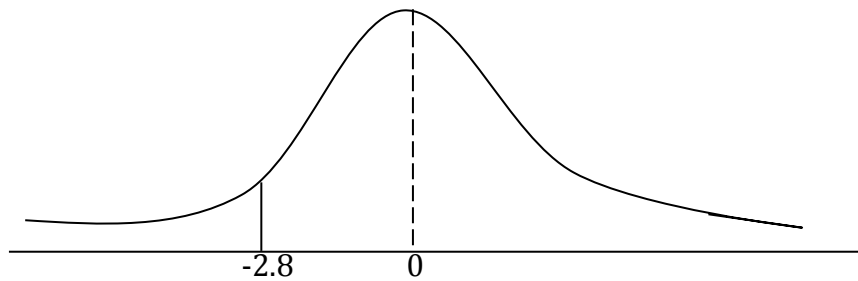

$$\begin{aligned} P(Z < -2.8) &= 0.5 - P(0 < Z < -2.8) \\ &= 0.5 - 0.4974 \\ &= 0.0026 \end{aligned}$$

Since there are 5000 packets, multiply the probability by 5000

$$5000 \times 0.0026 = 13$$

Therefore 13 packets have a mass less than 1.35 kg

Example 4

A machine used for filling bags with ground coffee, can be set to dispense any any required mean weight of coffee in the bag can be modeled by a normal distribution with a mean of 128 g and standard deviation of 1.95 g per bag. Calculate the percentage of bags that contain less than 125g.

Solution

X is the weight in grams of coffee in bag from machine

$$X \sim N(128, 1.95^2)$$

$$\begin{aligned} P(X < 125) &= P\left(Z < \frac{125-128}{1.95}\right) \\ &= P(Z < -1.538) \end{aligned}$$

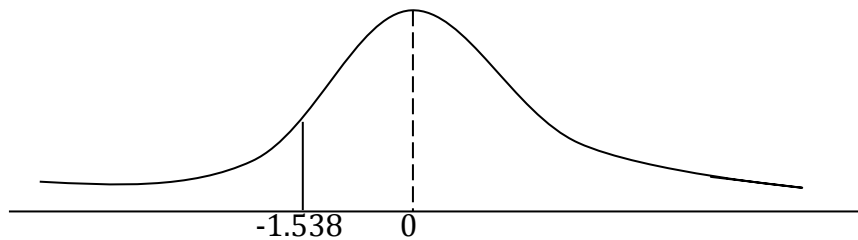

$$\begin{aligned} P(Z < -1.538) &= 0.5 - P(0 < Z < -1.538) \\ &= 0.5 - 0.4938 \\ &= 0.062 \\ &= 6.2\% \end{aligned}$$

6.2% of bags contain less than 125g

Example 5

The distribution of the masses of adult husky dogs may be modeled by the normal distribution with mean 37 kg and standard deviation of 5 kg. Calculate the probability that an adult husky dog has a mass greater than 30 kg.

Solution

X is the mass in kg of a husky dog

$$X \sim N(37, 5^2)$$

$$\begin{aligned} P(X > 30) &= P\left(Z > \frac{30-37}{5}\right) \\ &= P(Z > -1.4) \end{aligned}$$

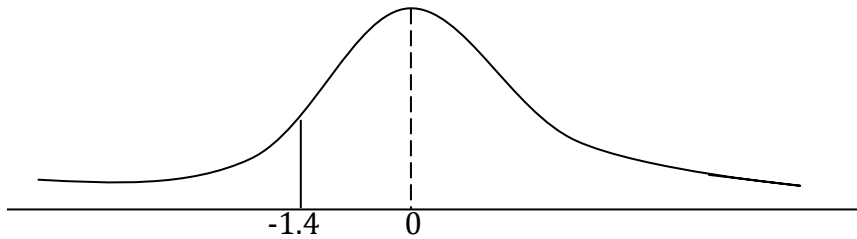

$$\begin{aligned} P(Z > -1.4) &= 0.5 + P(0 < Z < -1.4) \\ &= 0.5 + 0.4192 \\ &= 0.9192 \end{aligned}$$

Example 6

The marks of 500 candidates in an examination are normally distributed with a mean of 45 marks and standard deviation of 20 marks. Given that the pass mark is 41, estimate the number of candidates who passed the examination

Solution

X is the examination mark

$$X \sim N(45, 20^2)$$

$$\begin{aligned} P(X > 41) &= P\left(Z > \frac{41-45}{20}\right) \\ &= P(Z > -0.2) \end{aligned}$$

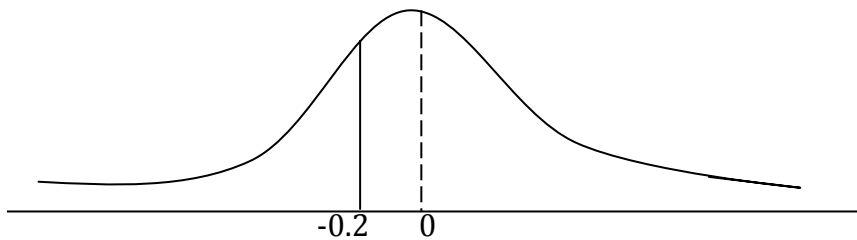

$$\begin{aligned} P(Z > -0.2) &= 0.5 + P(0 < Z < -0.2) \\ &= 0.5 + 0.0793 \end{aligned}$$

$$P(\text{pass}) = 0.5793$$

Since there are 500 candidates, to find the number of candidates who pass, multiply the probability by 500.

$$500 \times 0.5793 = 289.65$$

Therefore 290 candidates passed the examination

Trial questions

1. The masses of packages from a particular machine are normally distributed with a mean of 200 g and standard deviation of 2 g. Find the probability that a randomly selected package from the machine weighs

- (a) Less than 197 g
- (b) More than 200.5 g
- (c) Between 198.5 g and 199.5 g

[Ans: (a) 0.0668 (b) 0.4013 (c) 0.1747]

2. The heights of boys at a particular age follow a normal distribution with mean 150.3 and variance 25 cm . Find the probability that a boy chosen at random from his age group has a height
- (a) less than 153 cm
 - (b) more than 158 cm
 - (c) between 150 cm and 158 cm

[Ans: (a) 0.7054 (b)0.0618 (c) 0.4621]

3. The random variable X is distributed normally such that $X \sim N(50, 20)$. Find

- (a) $P(X > 60.3)$
- (b) $P(X < 59.8)$

[Ans: (a) 0.0106 (b)0.9857]

4. The masses of a certain type of cabbage are normally distributed with a mean of 1000g and standard deviation of 150 g. In a batch of 800 cabbages, estimate how many have a mass between 750 g and 1290 g. [Ans: 740]

5. The lifetime of a certain make of electric bulbs is known to be normally distributed with a mean life of 2000 hours and standard deviation of 120 hours. Estimate the probability that the life of such a bulb will be;

- (a) greater than 2150 hours
- (b) greater than 1910 hours
- (c) between 1850 hours and 2090 hours

[Ans: (a) 0.1056 (b) 0.7734 (c) 0.6678]

6. The manufacturers of a new model of a car state that, when travelling at 56 miles per hour, the petrol consumption has a mean value of 32.4 miles per gallon with standard deviation of 1.4 miles per gallon. Assuming a normal distribution, calculate the probability that a randomly chosen car of that model will have a petrol consumption greater than 30 miles per gallon when travelling at 56 miles per hour. [Ans: 0.957]

CHAPTER 20: LINEAR MOTION

Linear motion refers to motion in a straight line.

Displacement : it is the distance covered in a particular direction. it is a vector quantity.

Distance travelled = speed x time

$$S = v \times t$$

The gradient of the displacement time graph represents velocity

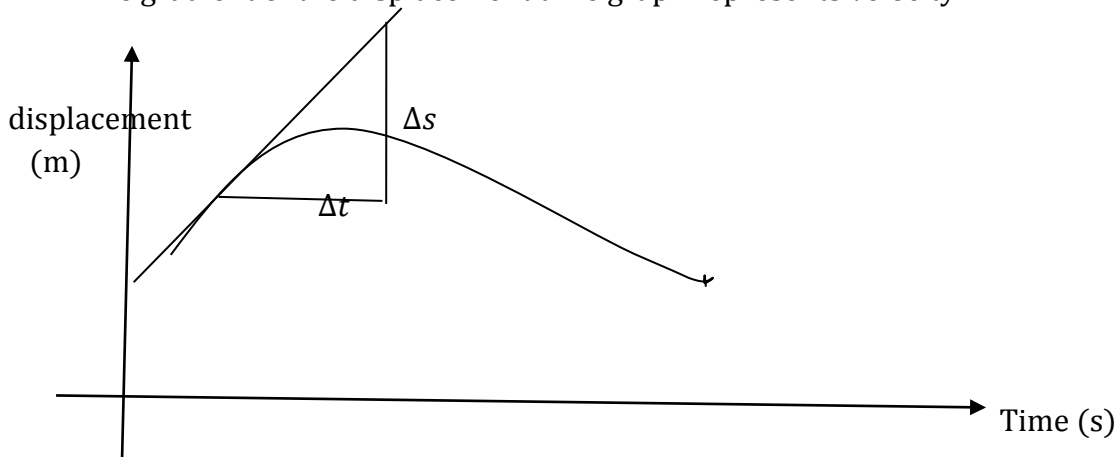

$$\text{Gradient} = \frac{\Delta S}{\Delta T} = \text{Velocity (ms}^{-1}\text{)}$$

Velocity:

This is the measure of the speed at which a body travels in a given direction.

The area under the velocity time graph represents displacement and the gradient of the velocity time graph represents acceleration.

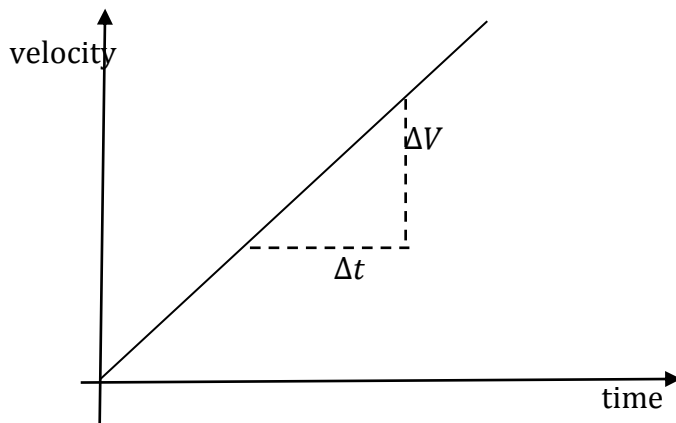

$$\text{Gradient} = \frac{\Delta V}{\Delta T}$$

$$\text{But acceleration} = \frac{\text{change in velocity}}{\text{time taken for the change}} = \frac{\Delta V}{\Delta T}$$

$$a = \frac{\Delta V}{\Delta T}$$

Note : Acceleration is the rate of change of velocity and negative acceleration means retardation or deceleration.

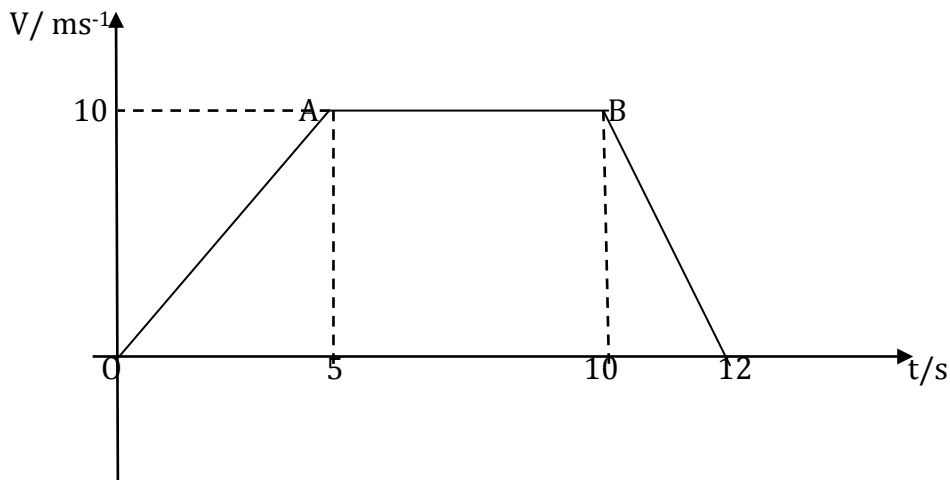
Example of a velocity time graph

- The starts at $t = 0$, from rest (i.e with zero velocity). From O to A , the velocity increases steadily until it reaches 10 m/s at time $t = 5\text{s}$. Since OA is a straight line, the acceleration is uniform or constant and equal to $\frac{10}{5} = 2\text{ms}^{-2}$. At A , acceleration ceases.
- From A to B , the body travels with uniform/constant velocity of 10ms^{-1}
- From B to C , the velocity decreases steadily and the body comes to rest again has a uniform retardation of $\frac{10}{2} = 5\text{ms}^{-2}$.
- Average speed = $\frac{\text{total distance covered}}{\text{total time taken}}$

The equations of linear motion

There are three equations of linear motions which are expressed in terms of initial velocity, final velocity, displacement/ distance, time and acceleration. The students are only required to memorise these equations and apply them to solve problems related to linear motion. Their derivation is not important at this stage.

$$\text{Equation 1 : } V = U + at$$

$$\text{Equation 2 : } S = Ut + \frac{1}{2}at^2$$

$$\text{Equation 3 : } V^2 = U^2 + 2aS$$

Example 1

A car starts from rest, accelerates at 0.8ms^{-2} for 10s and then continues at a steady speed for a further 20s . Draw a velocity time graph and find the total distance travelled.

Solution

$$U = 0, \quad t = 10\text{s}, \quad a = 0.8\text{ms}^{-2}, \quad v = ?, \quad S = ?$$

$$\text{From; } V = U + at$$

$$V = 0 + 0.8 \times 10$$

$$V = 8 \text{ ms}^{-1}$$

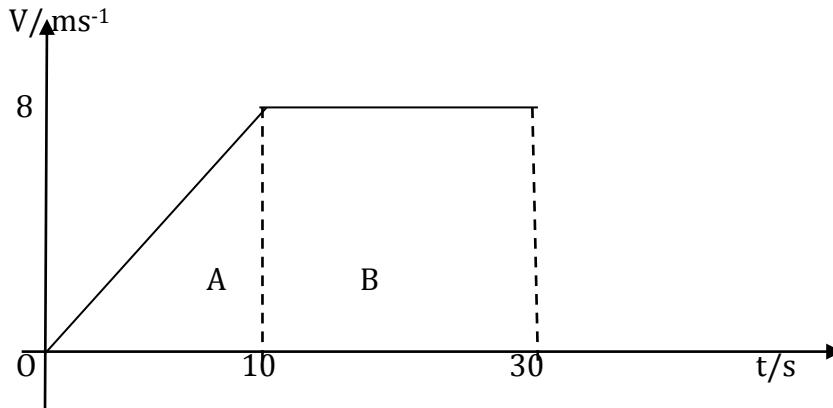

$$\begin{aligned}
 \text{Total distance covered} &= \text{Area under the graph} \\
 &= \text{Area A} + \text{Area B} \\
 &= \frac{1}{2} \times 10 \times 8 + 20 \times 8 \\
 &= 40 + 160 \\
 &= 200 \text{ m}
 \end{aligned}$$

Example 2

A car starts from rest, accelerating at 1 ms^{-2} for 10s. It then continues at a steady speed for a further 20s and decelerates to rest in 5s. Find

- (i) The distance travelled in m
- (ii) Average speed in ms^{-1}
- (iii) Time taken to cover half the distance

Solution

- (i) $U = 0$, $a = 1 \text{ ms}^{-2}$, $t = 10\text{s}$, $v = ?$
 $V = 0 + 10 \times 1$
 $V = 10 \text{ ms}^{-1}$

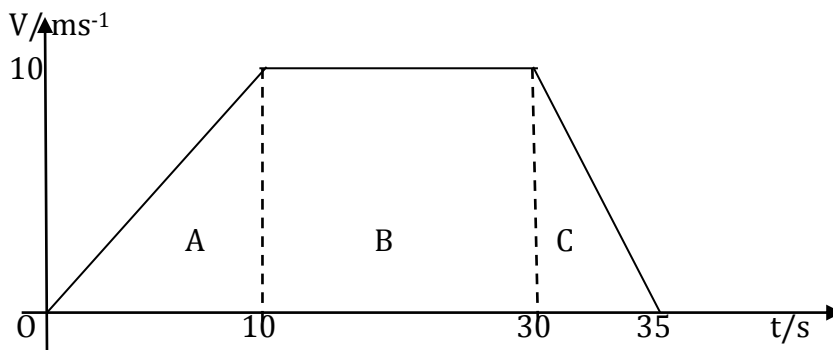

$$\begin{aligned}
 \text{Total distance covered} &= \text{Area under the graph} \\
 &= \text{Area A} + \text{Area B} + \text{Area C} \\
 &= \frac{1}{2} \times 10 \times 10 + 20 \times 10 + \frac{1}{2} \times 5 \times 10 \\
 &= 50 + 200 + 25 \\
 &= 275 \text{ m}
 \end{aligned}$$

- (ii) Average Speed = $\frac{\text{total distance covered}}{\text{total time taken}} = \frac{275}{35} = 7.857$
 (iii) Half the distance = $\frac{1}{2} \times 275 = 137.5$

$$\text{Time taken} = \frac{\text{distance}}{\text{average speed}} = \frac{137.5}{7.857} = 17.5s$$

Example 3

A body decelerating at 0.8ms^{-2} , a certain point with a speed of 30ms^{-1} . Find its velocity after 10s and the distance covered in that time.

Solution

$a = -0.8\text{ms}^{-2}$, $U = 30\text{ms}^{-1}$, $t = 10$, $V = ?$, $S = ?$

using the first equation of motion;

$$V = U + at$$

$$V = 30 + (-0.8)(10)$$

$$V = 30 - 8 = 22 \text{ms}^{-1}$$

Using the third equation of motion

$$V^2 = U^2 + 2aS$$

$$22^2 = 30^2 + 2 \times -0.8S$$

$$484 = 900 - 1.6S$$

$$-416 = -1.6S$$

$$S = \frac{416}{1.6} = 260m$$

Example 4

A particle moving along a straight line with uniform acceleration covers the first two consecutive distances of 100m and 140m in the time intervals of 20s and 40s respectively.

(a) Calculate the

- (i) Acceleration and initial velocity of the particle
- (ii) Total time taken before it comes to rest.

(b) Sketch the motion of the particle

Solution

Let the initial velocity and acceleration be u and a respectively

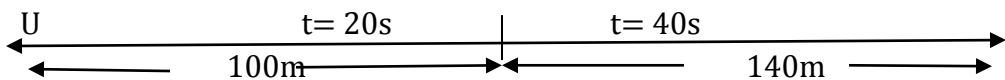

Total time = 60s

total distance = 240m

$$S = ut + \frac{1}{2}at^2$$

$$100 = 20u + \frac{1}{2}a (20)^2$$

$$100 = 20u + 200a \dots\dots\dots(i)$$

$$240 = 60u + \frac{1}{2}a (60)^2$$

$$240 = 60u + 1800a \dots\dots\dots(ii)$$

9 (i) - (ii) gives;

$$660 = 120u$$

$$u = 5.5\text{m/s}$$

$$100 = 110 + 200a$$

$$- 10 = 200a$$

$$a = \frac{-10}{200}$$

$$a = -0.05\text{ms}^{-2}$$

Example 5

A particle is moving in a straight line with a constant velocity of 60ms^{-1} for 3s. Then there is a constant acceleration of -3ms^{-2} for 5s.

- (a) Draw a velocity time graph for its motion
 (b) Find the distance it has travelled

Solution

- (a) For $U = 60\text{ms}^{-1}$, $t = 5\text{s}$, $a = -3\text{ms}^{-2}$

$$V = u + at$$

$$V = 60 + -3 \times 5$$

$$V = 45\text{ms}^{-1}$$

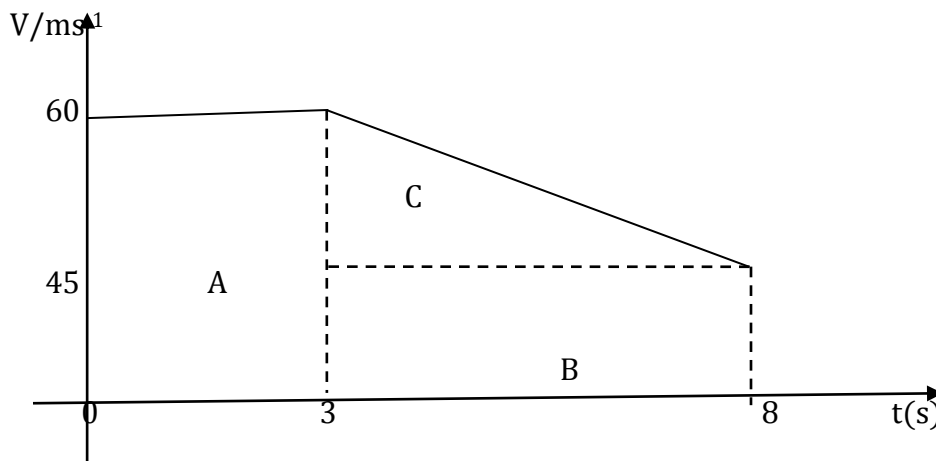

- (b) Total distance covered = Area under the graph
 = Area A + Area B + Area C
 = $(3 \times 60) + (5 \times 45) + \frac{1}{2} \times 5 \times 15$
 = $180 + 225 + 37.5 = 442.5\text{m}$

Example 6

A particle starts from rest, moving with a constant acceleration of 1.5ms^{-2} for 12 seconds. For the next 48s, the acceleration is $\frac{1}{8}\text{ms}^{-2}$ and for the last 10s it decelerates uniformly to rest.

- i) Sketch the velocity time graph for the particle's motion.
 ii) Find the distance travelled by the particle
 iii) Calculate the average velocity of its motion

Solution

- | | | |
|----|-----------------------|----------------------------------|
| i) | First acceleration | second acceleration |
| | $a = 1.5\text{m/s}^2$ | $u = 90\text{m/s}, v = ?$ |
| | $U = 0$ | $a = \frac{1}{8}$ |
| | $V = U + at$ | $t = 48$ |
| | $V = 1.5 \times 12$ | $v = 90 + \frac{1}{8} \times 48$ |

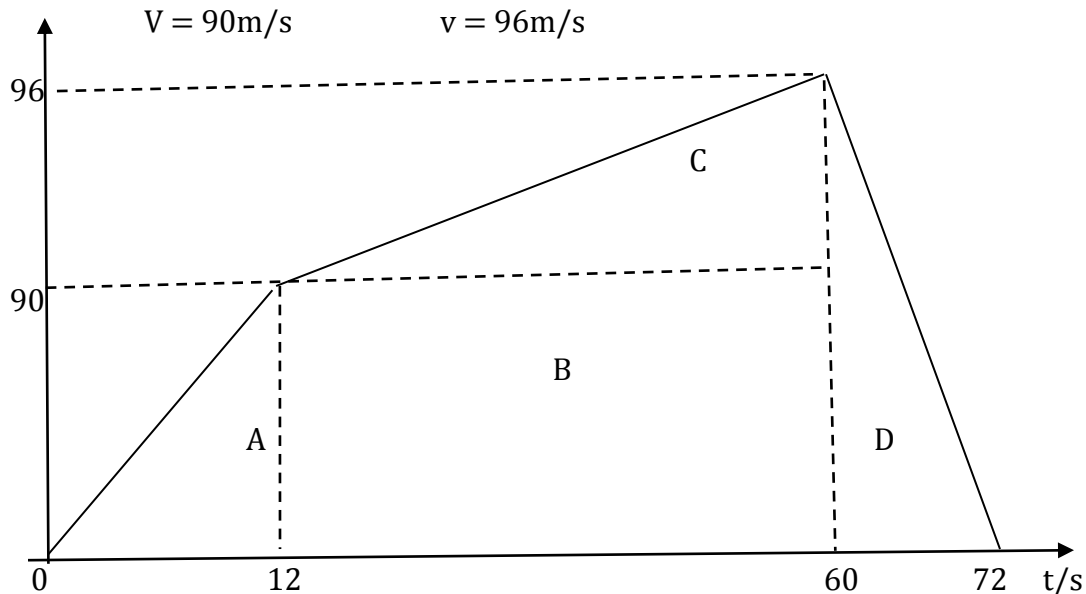

(i) Total distance covered = Total area under graph

$$\begin{aligned}
 &= \text{Area A} + \text{Area B} + \text{Area C} + \text{Area D} \\
 &= \left(\frac{1}{2} \times 12 \times 90\right) + (48 \times 90) + \left(\frac{1}{2} \times 48 \times 6\right) + \left(\frac{1}{2} \times 10 \times 96\right) \\
 &= 540 + 4320 + 144 + 480 \\
 &= 5484 \text{ m}
 \end{aligned}$$

(ii) Average speed = $\frac{\text{total distance covered}}{\text{total time taken}}$

$$\begin{aligned}
 &= \frac{5484}{70} = 78.34 \text{ ms}^{-1}
 \end{aligned}$$

Example 7

A particle starts from rest, moving with a constant acceleration of 1.5 ms^{-2} for 30s. For the next 60s, the acceleration is 0.3 ms^{-2} . For the last 25s, it decelerates uniformly to rest.

- Sketch the velocity time graph for the motion of the particle
- Find the acceleration of the particle during the last period of the journey.
- Determine the total distance travelled by the particle
- Find the average speed for the whole journey

Solution

- | | | |
|-----|---------------------------|---------------------------|
| (i) | First acceleration | second acceleration |
| | $a = 1.5 \text{ ms}^{-2}$ | $t = 60 \text{ s}$ |
| | $t = 30 \text{ s}$ | $a = 0.3 \text{ ms}^{-2}$ |
| | $U = 0$ | $u = 45 \text{ m/s}$ |

Using $V = U + at$

$$\begin{aligned}
 V &= 1.5 \times 30 \\
 V &= 45 \text{ ms}^{-1}
 \end{aligned}$$

$$\begin{aligned}
 V &= U + at \\
 V &= 45 + 0.3 \times 60 \\
 V &= 63 \text{ ms}^{-1}
 \end{aligned}$$

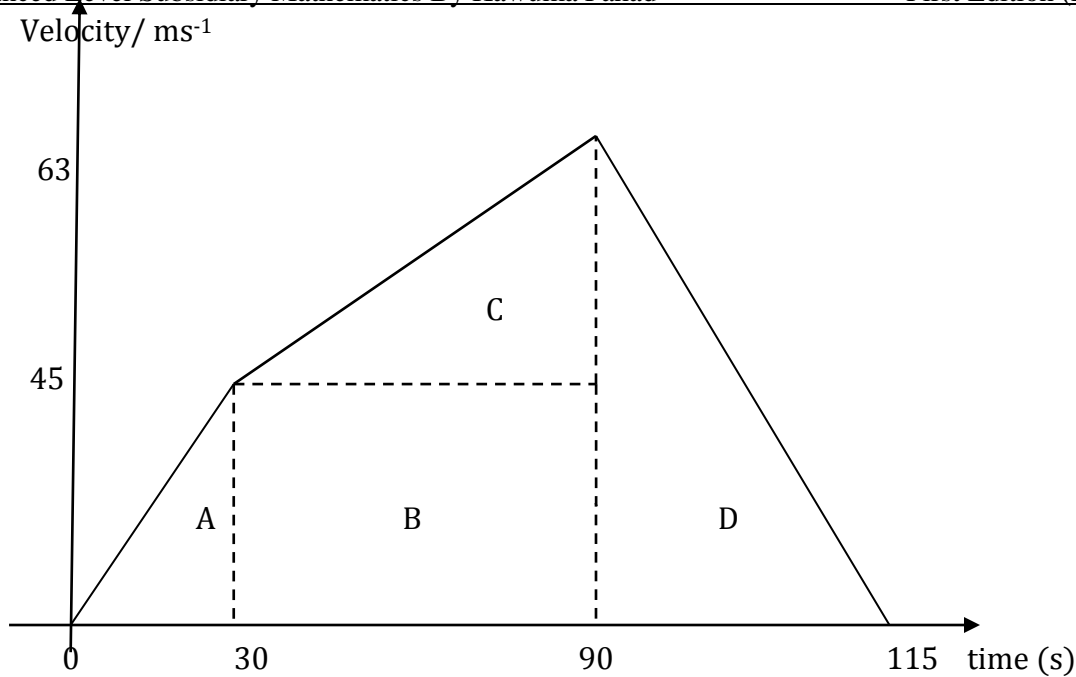

(ii) $u = 63\text{ms}^{-1}$, $V = 0$, $t = 25\text{s}$

$$a = \frac{v-u}{t}$$

$$a = \frac{0-63}{25}$$

$$a = -2.52\text{ms}^{-2}$$

(iii) Total distance travelled by the particle = total area under graph

$$= \text{Area A} + \text{Area B} + \text{Area C} + \text{Area D}$$

$$= \left(\frac{1}{2} \times 30 \times 45\right) + (60 \times 45) + \left(\frac{1}{2} \times 60 \times 18\right) + \left(\frac{1}{2} \times 25 \times 63\right)$$

$$= 675 + 2700 + 540 + 787.5$$

$$= 4702.5\text{m}$$

(iv) Average speed = $\frac{\text{total distance covered}}{\text{total time take}} = \frac{4702.5}{115} = 40.89 \text{ms}^{-1}$

Example 8

The table below shows the velocity of a particle during the course of its motion

t(s)	0	5	10	15	20	25	30
V(m/s)	0	4	8	8	8	7	6

Plot a graph of velocity against time and use it to find

- The retardation of the body during the last 10s
- The total distance travelled by the particle
- Describe the condition of the particle during the period 10s to 20s

Solution

(i)

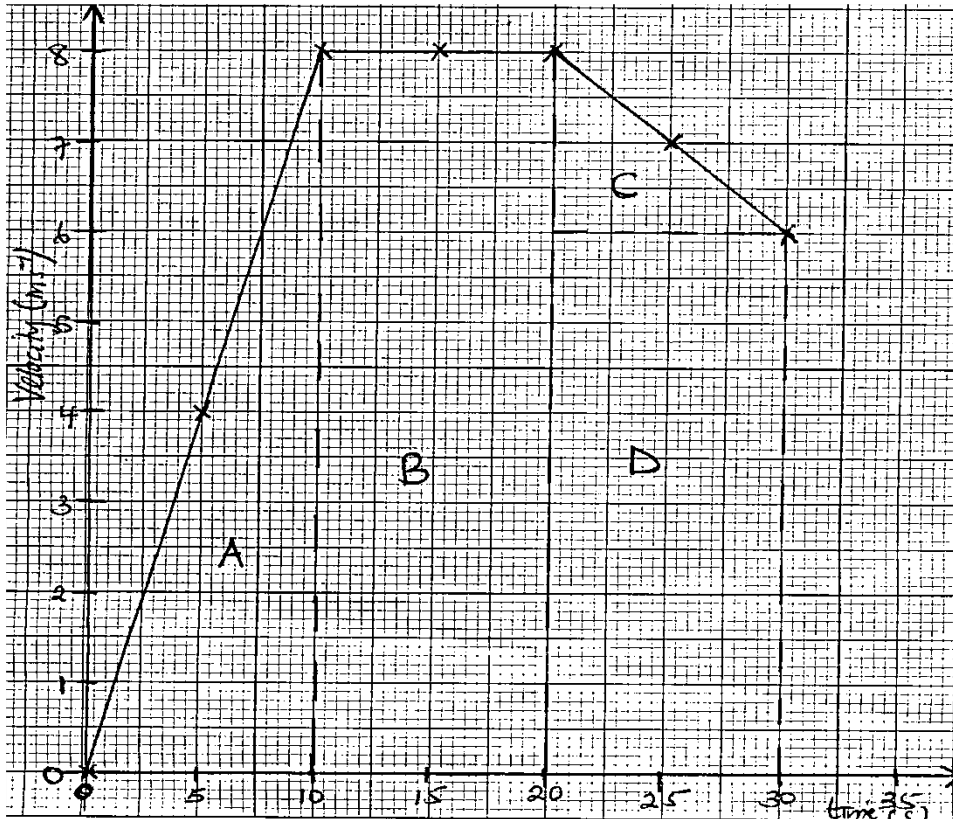

(ii) Total distance travelled by the particle = total area under graph

$$\begin{aligned}
 &= \text{Area A} + \text{Area B} + \text{Area C} + \text{Area D} \\
 &= \left(\frac{1}{2} \times 10 \times 8\right) + (10 \times 8) + \left(\frac{1}{2} \times 10 \times 2\right) + (10 \times 6) \\
 &= 40 + 80 + 10 + 60 \\
 &= 190\text{m}
 \end{aligned}$$

(iii) The particle travels with a constant velocity of 8ms^{-1} **Trial questions:**

- A particle travelling with an acceleration of 0.7 ms^{-2} passes a point 0 with speed 5 ms^{-1} . How long will it take to cover a distance of 250 m from? what will its speed be at this time ? (Ans: 20s, 20ms^{-1})
 - If particle passes a certain point with speed 5ms^{-1} and is accelerating at 3 ms^{-2} . How far will it travel in the next 25 ? How long will it take to travel 44 m from the start ? (Ans ; 16m, 4s)
 - A car starting from rest moves with a constant acceleration of $x\text{ ms}^{-2}$ 10s and travels with constant velocity for a further 10s and then retards at $2x\text{ ms}^{-2}$ to come to rest 300m from its starting point. Find the value of x (Ans : $x = \frac{12}{7}$ hint : sketch a v-t graph)
 - A motorist starting a car from rest accelerates uniformly to a speed of $V\text{ms}^{-1}$ in 10s . He maintains this speed for another 50s and then applies brakes and decelerates uniformly to rest. His deceleration is numerically equal to twice the acceleration
- (i) sketch a velocity time graph

- (ii) Calculate the time during which the deceleration takes place
 (iii) given that the total distance covered is 575m, calculate the value of V
 (iv) Calculate the initial acceleration [Ans: (ii) 5 s (iii) 10 ms^{-1} (iv) 1 ms^{-2}]
 5. Four points A,B,C and D lie on a straight road such that BC and CD are 448 cm and 576 cm respectively. A cat moving along this road covers each of these distances from A to D at 8s intervals with a constant acceleration

Find (i) the constant acceleration

(ii) Its speed at A to D

(iii) The distance AB

6. A motorist accelerates uniformly from rest at a rate of $a \text{ ms}^{-2}$ for 10s and then travels at a constant speed for 20s and slows down to rest at a constant retardation of $2a \text{ ms}^{-2}$. if the total distance is 550 m.

(i) Sketch the velocity time graph for the motion of the motorist

(ii) Find the value of a [Ans: 2 ms^{-2}]

(iii) Find the maximum speed attained by the motorist [ans: 20 ms^{-1}]

7. A body starts from rest and accelerates at 3 ms^{-2} for 4s. It then travels with a maximum velocity for a further 3s and it finally to rest with a uniform retardation after another 5s. By sketching a velocity time graph. Find the average velocity for the whole journey. [Ans: 7.5 ms^{-1}]

8. A car travels along a straight road between two trading centers P and Q. The car starts from rest at P and accelerates at 2.5 ms^{-2} until it reaches a speed of 40 ms^{-1} . It then travels at this steady speed for distance of 3,120m and then decelerates at 4 ms^{-2} to come to rest at Q.

(a) Sketch a velocity time graph for the motion of the car

(b) Determine the

(i) Total time taken for the car to move from P to Q

(ii) Distance from P to Q

(iii) Average speed of the car [Ans: 104 s, 3640 m, 35 ms^{-1}]

9. A body moves along a straight line uniformly increasing its velocity from 2 ms^{-1} to 18 ms^{-1} in a time interval of 10s. Find the acceleration of the body during this time and the distance travelled. (Ans : 1.6 ms^{-2} , 100m)

10. the table below shows the velocity of a particle during the course of its motion

Time (s)	0	5	10	20	30	60
Velocity (ms^{-1})	0	10	20	20	20	0

Plot a graph of velocity against time and use it to find the

(i). acceleration in the first 10s [2 ms^{-2}]

(ii). Total distance covered [800 m]

(iii) Describe the motion of the particle during the period $t = 10\text{s}$, $t = 30\text{s}$

11. A cyclist starting from rest accelerates uniformly until he reaches his maximum speed of 12 ms^{-2} . He continues at this steady speed for next 2.4km. He then applies brakes and decelerates to rest at a rate numerically equal to four times that of his acceleration. Sketch a velocity time graph.

Given that the total distance travelled by the cyclist is 2.52km, calculate.

(i) The time during which the acceleration takes place (Ans: 4 s)

(ii) The distance over which deceleration takes place (24 m)

(iii) The total time for which the cyclist is in motion (240 s)

CHAPTER 21: RESULTANT AND COMPONENTS OF FORCES**Resultant of two forces**

The resultant R of two forces P and Q is that single force which could completely take the place of the two forces. The Resultant R must have the same effect as the two forces P and Q .

When only parallel forces are involved. It is easy to find the resultant. For example.

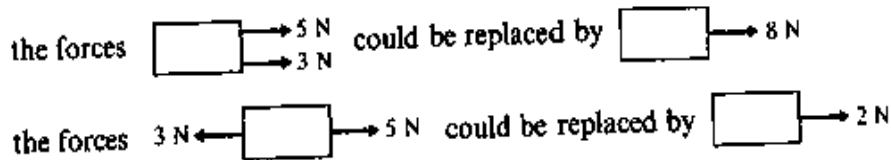
**Resolving a force: Components**

The component of the force F in any given direction is the measure of the effect of the force F in that direction.

Consider a force F acting at an angle θ to the x -axis as shown below. Let AB represent the force F and the angle $BXO = 90^\circ$, AX and AY represent the horizontal and vertical components of F , along the x and y axes respectively.

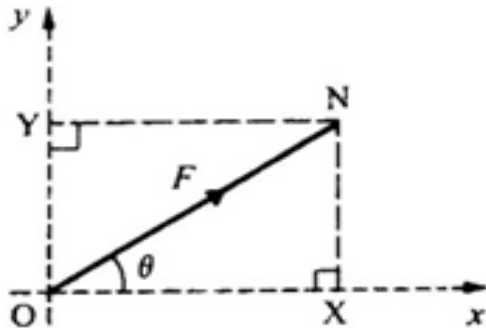

$$\frac{AX}{AB} = \cos \theta \quad \text{and} \quad \frac{AY}{AB} = \cos BAY$$

$$AX = AB \cos \theta \quad AY = AB \cos(90^\circ - \theta)$$

$$AX = F \cos \theta \quad AY = F \sin \theta$$

Hence the components are $F \cos \theta$ and $F \sin \theta$ along the x and y axes respectively

Note: The rule for finding the components may be stated as;

The component of force in any direction is the product of the magnitude of the force and the Cosine of the angle between the force and the required direction i.e. $F \cos \theta$ and $F \cos(90^\circ - \theta) = F \sin \theta$

Example 1

Find the components of the given forces in the direction of

- (i) The x -axis (ii) The y -axis

(a)

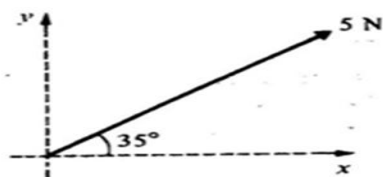

(i) Component along the x -axis = $5 \times \cos 35^\circ$
= 4.10 N

(ii) Component along the y -axis = $5 \times \cos(90^\circ - 35^\circ)$

$$= 5\cos 55^\circ \text{ or } 5\sin 35^\circ$$

$$= 2.87\text{N}$$

(b)

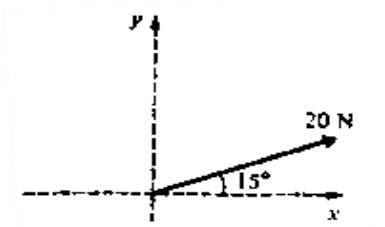

(i) Component along the x-axis = $20\cos 15^\circ$
 $= 19.3\text{N}$

(ii) Component along the y-axis = $20 \sin 15^\circ$
 $= 5.18\text{N}$

(c)

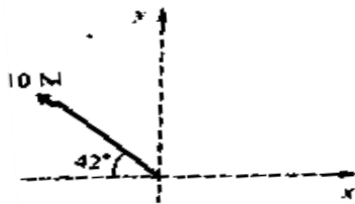

(i) Component along the x-axis = $10\sin 42^\circ$
 $= -7.43\text{N}$

(ii) Component along the y-axis = $10 \sin 42^\circ$
 $= 6.69\text{N}$

Example 2

Find the sum of the components of the given factors in the direction of

(i) The x-axis (ii) The y-axis

a)

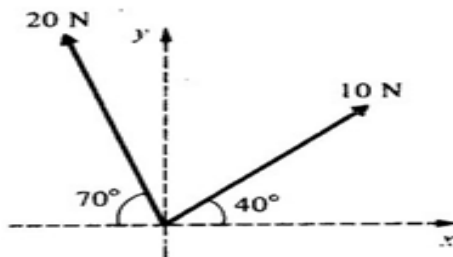

(i) Resolving along the x-axis
 $10\cos 40^\circ - 20\cos 70^\circ = 7.66 - 6.84$
 $= 0.82\text{N}$

(ii) Resolving along the y-axis
 $10\sin 40^\circ + 20\sin 70^\circ = 6.43 + 18.79$
 $= 25.22\text{N}$

b)

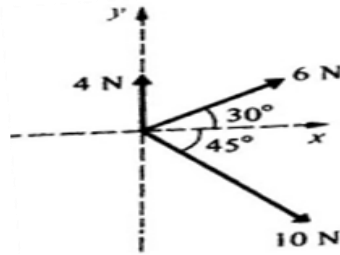
**Solution**

- (i) Resolving along the x-axis
 $6\cos 30^\circ + 10\cos 45^\circ = 5.20 + 7.07$
 $= 12.27\text{N}$
- (ii) Resolving along the y-axis
 $4 + 6\sin 30^\circ - 10\sin 45^\circ = 4 + 3 - 7.07$
 $= 7 - 7.07$
 $= -0.07\text{N}$

Note: When summing up components of the forces, due regard should be given to the directions of the components.

Again if x and y are the magnitude of the perpendicular components of a force AB , the magnitude of AB is given by;

$$AB = \sqrt{x^2 + y^2} \quad \text{and the direction of } AB \text{ is given by } \tan \theta = \frac{x}{y}$$

Example 3

Two forces of 7N and 24N act away from the point A and make an angle of 90° with each other. Find the magnitude and direction of their resultant.

Solution

First make a rough sketch

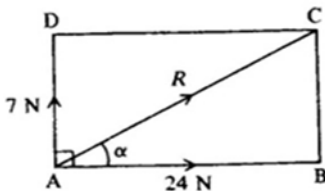

$$R^2 = 7^2 + 24^2 \quad (\text{Pythagoras theorem})$$

$$R^2 = 625$$

$$R = 25\text{N}$$

$$\tan \alpha = \frac{7}{24}$$

$$\alpha = 16.26^\circ$$

The resultant is 25N making an angle of 16.26° with the 24N force.

Example 4

Find the magnitude and direction of the resultant force

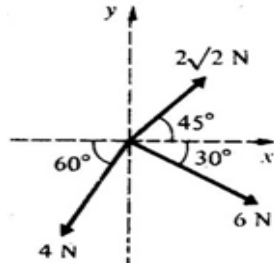
**Solution**

Resultant force horizontally

$$2\sqrt{2}\cos 45 - 6\cos 30 - 4\cos 60 = 2 - 5.20 - 2 \\ = -5.20\text{N}$$

Resultant force vertically

$$2\sqrt{2}\sin 45 - 6\sin 30 - 4\sin 60 = -1 - 3.464 \\ = -4.464$$

$$R = \sqrt{(-5.20)^2 + (-4.464)^2} \\ R = 6.85\text{ N}$$

Example 5

Find the resultant of the given forces, by finding the components of the forces in the direction of the x and y axes

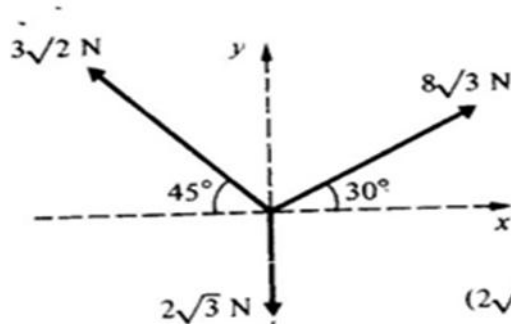
**Solution**

Components in the direction of x-axis

$$= 8\sqrt{3}\cos 30^\circ - 3\sqrt{2}\cos 45^\circ \\ = 8\sqrt{3} \times \frac{\sqrt{3}}{2} - 3\sqrt{2} \times \frac{\sqrt{2}}{2} \\ = 12 - 3 \\ = 9\text{ N}$$

Components in the direction of y-axis

$$= 8\sqrt{3}\sin 30^\circ + 3\sqrt{2}\sin 45^\circ - 2\sqrt{3} \\ = 8\sqrt{3} \times \frac{1}{2} + 3\sqrt{2} \times \frac{\sqrt{2}}{2} - 2\sqrt{3} \\ = (2\sqrt{3} + 3)\text{N}$$

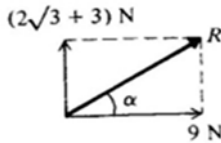

$$R^2 = 9^2 + (2\sqrt{3} + 3)^2$$

$R = 11.1$ N and the direction is at an angle α to the x-axis, where

$$\tan \alpha = \frac{(2\sqrt{3}+3)}{9}$$

$$\alpha = 35.69^\circ$$

The resultant is 11.1 N at an angle of 35.69° above the x-axis

Example 6

ABCD is a rectangle. Forces of 9 N, 8 N and 3 N act along the lines DC, CB and BA respectively, in the directions indicated by the order of the letters. Find the magnitude of the resultant and the angle it makes with DC.

Solution

Draw a diagram showing the forces

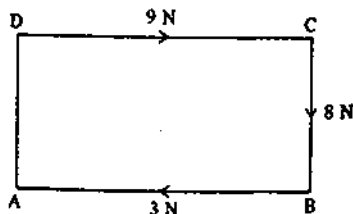

Resolving parallel to DC gives horizontal component = $9 - 3 = 6$ N

Resolving parallel to CB gives vertical component = 8 N

$$R^2 = 6^2 + 8^2$$

$$= 36 + 64 = 100$$

$$R = 10$$
 N

Drawing a diagram to show the two components

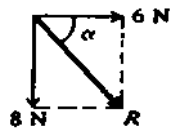

The direction is seen to be given by;

$$\tan \alpha = \frac{8}{6}$$

$$\alpha = 53.13^\circ$$

The resultant is 10 N making an angle of 53.13° with DC

Trial questions

1. ABCD is a rectangle. Forces $6\sqrt{3}$ N, 2 N and $4\sqrt{3}$ N act along AB, CB and CD respectively, in the direction indicated by the order of the letters. Find the magnitude of the resultant and the angle it makes with AB [Ans: 4 N, 30°]
2. ABCD is a rectangle. Forces of 8 N, 4 N, 10 N and 2 N act along AB, CB, CD and AD respectively in the directions indicated by the letters. Find the magnitude and direction of the resultant force. [Ans: 2.83 N, 45° with BA]

3. ABCD is a rectangle. Forces of 3 N, 4 N and 1 N act along AB, BC and CD respectively in the directions indicated by the order of the letters. Find the magnitude of the resultant and the angle it makes with AB. [Ans: 5.66 N, 45°]
4. Four forces of magnitude 2 N, 4 N, 3 N and 4 N act at a point in the directions whose bearings are 000° , 060° , 180° , 270° respectively. Calculate the magnitude of the resultant. [Ans: 1.49 N]
5. Each of the following diagrams shows a number of forces. Calculate the magnitude of their resultant.

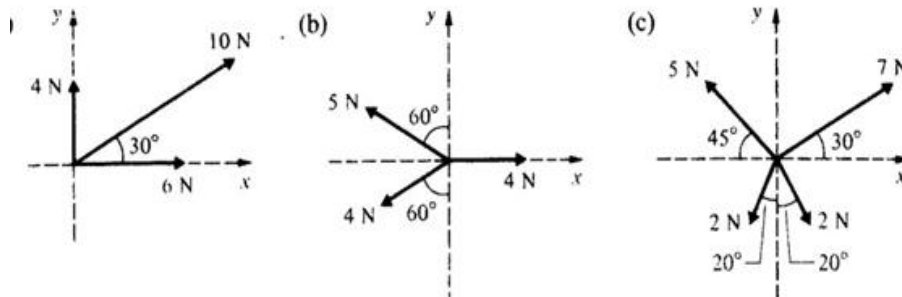

[Ans: (a) 17.2 N (b) 3.8 N (c) 4.1 N]

6. Find the magnitude and direction of the forces in the given diagrams below

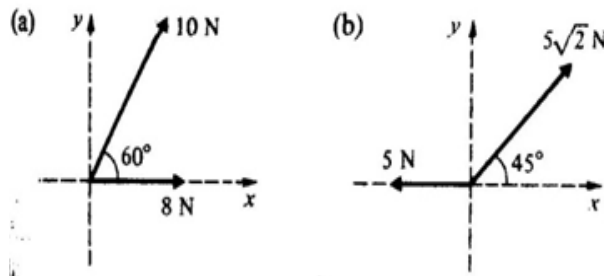

[Ans: (a) 15.6 N, 33.7° (b) 5 N, 90°]

7. ABCD is a square. Forces of 4 N, 3 N, 2 N and 5 N act along the sides AB, BC, CD and AD respectively in the directions indicated by the letters. Calculate the magnitude of the resultant and the angle it makes with AB. [Ans: 8.2 N, 76°]

CHAPTER 22: FRICTION

The frictional force is the force that acts to oppose the relative motion of two bodies in contact ie if one pushes the block on the table with a small force P, the frictional force F comes in to operation and opposes the possible movement.

Coefficient of friction

The magnitude of maximum frictional force is proportional to the normal reaction R .The friction constant is called the coefficient of friction , μ , for two surfaces in contact

$$F_{\max} = \mu R$$

For a perfectly smooth surface, $\mu = 0$

Consider a block of mass M kg resting on a horizontal table and a horizontal force P N is applied

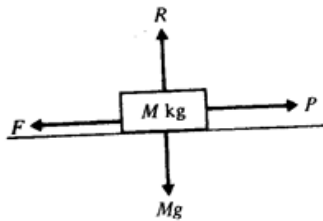

$$R = Mg$$

$$F = \mu Mg \quad \text{where } g = \text{acceleration due to gravity}$$

Example 1

1. Calculate the maximum frictional force which can act when a block of mass rests on a rough horizontal surface if the coefficient of friction is (a) 0.7 (b) 0.2

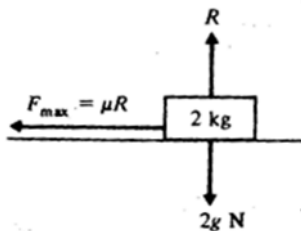
solution

There is no motion perpendicular to the plane

Resolve vertically: $R = 2g$

$$R = 2 \times 9.8$$

$$R = 19.6 \text{ N}$$

$$F_{\max} = \mu R$$

$$F_{\max} = 0.7 \times 19.6$$

$$= 13.72 \text{ N}$$

a) As before

$$R = 19.6 \text{ N}$$

$$F_{\max} = \mu R$$

$$F_{\max} = 0.2 \times 19.6$$

$$= 3.92 \text{ N}$$

Example 2

A block of mass 5 kg rests on a rough horizontal plane, the coefficient of friction between the block and the plane being 0.6. Calculate the frictional force acting on the block when a horizontal force P is applied to the block and the magnitude of P is

- (a) 12 N (b) 28 N (c) 36 N Also calculate the magnitude of any acceleration which may occur.

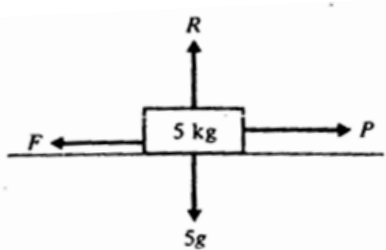
Solution

There is no motion perpendicular to the plane

$$\begin{aligned} \text{Resolve vertically: } R &= 5g \\ &= 49 \text{ N} \end{aligned}$$

The frictional force will act in the direction opposite to that in which the force P acts. The maximum value of frictional force is μR .

$$\begin{aligned} \mu R &= 0.6 \times 49 \\ &= 29.4 \text{ N} \end{aligned}$$

- (a) If $P = 12 \text{ N}$, then P is less than μR , so there is no motion

$$\begin{aligned} \text{Frictional force } F &= P \\ F &= 12 \text{ N} \end{aligned}$$

- (b) If $P = 28 \text{ N}$, then again P is less than μR and there is no motion

$$\begin{aligned} \text{Frictional force } F &= P \\ F &= 28 \text{ N} \end{aligned}$$

- (c) If $P = 36 \text{ N}$, then P is greater than the maximum value of frictional force, which is 29.4 N

Frictional force acting = 29.4 N, which does not prevent motion.

The block will move and the maximum value of μR will be maintained.

Using $F = ma$, the equation of motion is:

$$\begin{aligned} P - \mu R &= m \times a \\ 36 - 29.4 &= 5a \\ a &= 1.32 \text{ ms}^{-2} \end{aligned}$$

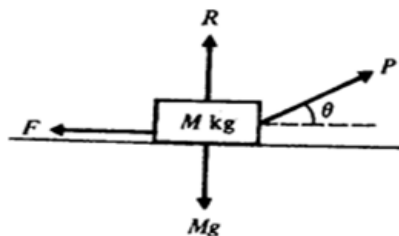
Applied force not horizontal

When a force on the block of mass M Kg is inclined at an angle θ above the horizontal, this has two effects;

- (i) The component of P in the vertical direction decreases the magnitude of the normal reaction R
- (ii) Only the component of P in a horizontal direction is tending to move the block

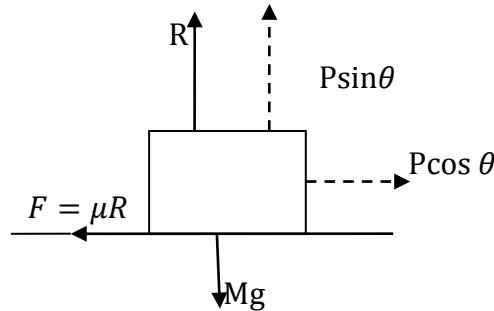

Resolving vertically: $R + P \sin \theta = Mg$

$$R = Mg - P \sin \theta \dots\dots\dots (i)$$

Resolving horizontally $P \cos \theta = F = \mu R \dots\dots\dots (ii)$

Example 1

A 10kg truck lies on a horizontal floor .This coefficient of friction between the truck and the floor is $\frac{\sqrt{3}}{4}$. Calculate magnitude of force P which is necessary to pull the truck horizontally if P is applied

- (i) Horizontally
- (ii) at 30° above the horizontal

solution

(a)

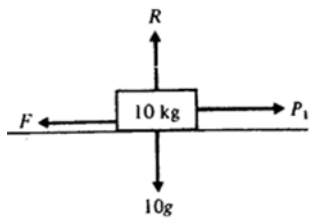

In the position of limiting equilibrium , $P_1 = F$

$$P_1 = \mu R$$

$$P_1 = \frac{\sqrt{3}}{4} \times 10g$$

$$P_1 = \frac{\sqrt{3}}{4} \times 10 \times 9.8$$

$$P_1 = 42.43 \text{ N}$$

For motion to take place, the applied force must exceed 42.43 N

(b)

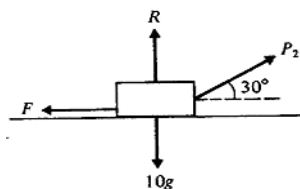

Resolving vertically; $R + P \sin 30^\circ = 10g$

$$R = 98 - P \sin 30^\circ$$

$$R = 98 - \frac{P}{2}$$

In the position of limiting equilibrium,

$$P \cos 30^\circ = \mu R$$

$$P \cos 30^\circ = \mu \left(98 - \frac{P}{2} \right)$$

$$P \times \frac{\sqrt{3}}{2} = 98 \mu - \frac{\sqrt{3}}{4} \times \frac{P}{2}$$

$$\frac{\sqrt{3}}{2} P + \frac{\sqrt{3}}{8} P = \frac{\sqrt{3}}{4} \times 98$$

$$P(5\sqrt{3}) = 2\sqrt{3} \times 98$$

$$P = 39.2 \text{ N}$$

Example 2

A box of mass 50kg is to be pushed along a rough floor by a force acting at the centre of its top surface. The force is in an angle of 60° to the horizontal. If the coefficient of friction is 0.25, calculate the least force which will move the box.

Solution

Let it be P

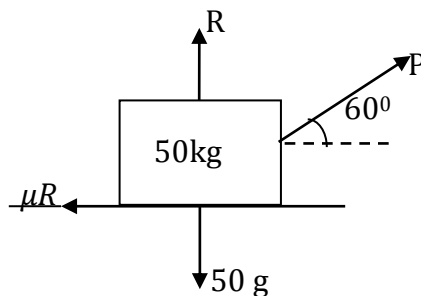

Resolving vertically ;

$$R + P \sin 60^\circ = 50g$$

$$R = 50g - P \sin 60^\circ$$

Resolving horizontally;

$$P \cos 60^\circ = \mu R$$

$$P \cos 60^\circ = 0.25 (50g - p \sin 60^\circ)$$

$$\frac{P}{2} = 12.5g - P \times \frac{\sqrt{3}}{2} \times \frac{1}{4}$$

$$\frac{p}{2} + \frac{\sqrt{3}}{8} p = 12.5 \times 9.8$$

$$P \left(\frac{1}{2} + \frac{\sqrt{3}}{8} \right) = 122.5$$

$$P (4 + \sqrt{3}) = 8 \times 122.5$$

$$P = \frac{980}{4 + \sqrt{3}}$$

$$P = 170.97 \text{ N}$$

Example 3

A particle of mass 2kg rests on a rough horizontal ground. The coefficient of friction between the particle and the ground is $\frac{1}{2}$. Find the magnitude of a force P acting up wards on the particle at 30° to the horizontal which will just move the particle.

Solution

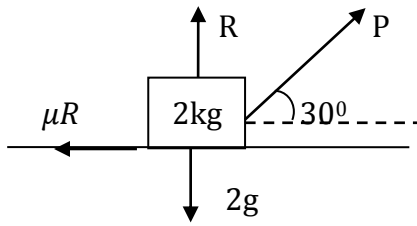

Resolving vertically;

$$R + P \sin 30 = 2g$$

$$R = 2g - P \sin 30$$

Resolving horizontally;

$$P \cos 30 = \mu R$$

$$P \cos 30 = \frac{1}{2} (2g - P \sin 30)$$

$$2P \times \frac{\sqrt{3}}{2} = 2g - P \times \frac{1}{2}$$

$$P\sqrt{3} + \frac{P}{2} = 19.6$$

$$P = \frac{19.6}{2.232}$$

$$P = 8.78 \text{ N}$$

Example 4

A parcel of mass 10kg rests on a lorry. When the lorry is accelerating at 1.5 m s^{-2} , the parcel is on the point of sliding back wards. What is the coefficient of friction between the parcel and the lorry?

Solution

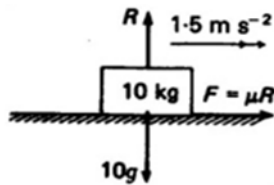

Vertically: $R = 10g$

From ; $F = 10 \times 1.5$

$$F = 15$$

$$\mu R = 15$$

$$\mu \times 10g = 15$$

$$\mu = \frac{15}{10 \times 9.8} = 0.153$$

Rough inclined plane

A body of mass $M \text{ kg}$ rests on a plane which is inclined at θ to the horizontal

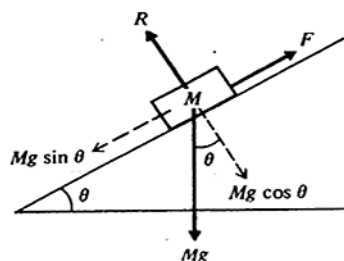

Resolving at right angles to the plane.

$$R = Mg \cos \theta$$

The component $Mg \sin \theta$ acting down the plane will cause motion unless the frictional force, F acting up the plane balances it.

At equilibrium $F = Mg \sin \theta$

$$F_{\max} = \mu R$$

$$F = \mu Mg \cos \theta = Mg \sin \theta$$

$$\mu = \tan \theta$$

Example 1

A body of mass 6kg rests in limiting equilibrium on a rough plane inclined at 30° to the horizontal. Find the coefficient of friction between the body and the plane.

Solution

since the body is on the point of moving down the plane, the friction force acts up the plane. The body rests on a plane which is inclined at θ to the horizontal.

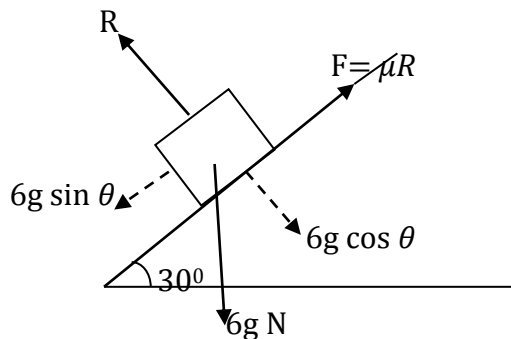

Resolving at right angles to the plane

$$R = 6g \cos 30^\circ$$

Resolving parallel to surface of the plane.

$$6g \sin 30 = \mu R$$

$$6g \sin 30 = \mu \times 6g \cos 30.$$

$$\mu = \frac{6g \sin 30}{6g \cos 30} = \tan 30$$

$$\mu = 0.577$$

Example 2

A mass of 10kg is placed on a plane inclined at an angle of 30° to the horizontal. What force parallel to the plane.

a) to hold the mass at rest

b) to make the mass move steadily up the plane [coefficient of friction between the mass and the plane is 0.4]

Solution

(a) As the block is just held at rest, it is on the verge of slipping down. Hence $F = \mu R$ acts upwards.

(b)

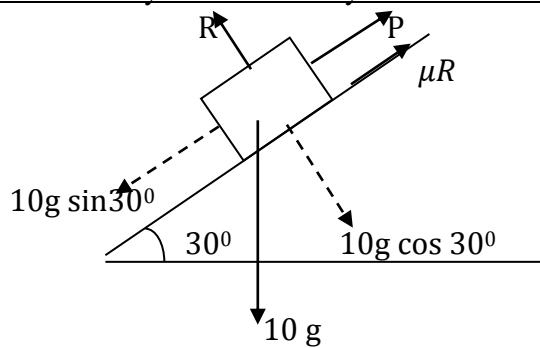

Resolving at right angles to the plane;

$$R = 10g \cos 30$$

Resolving parallel to the plane;

$$P + \mu R = 10g \sin 30$$

$$P + 0.4 (10g \cos 30) = 10g \sin 30$$

$$P = 10g \sin 30 - 4g \cos 30$$

$$P = 49 - 33.95$$

$$P = 15.5\text{N}$$

(b). If the mass is moving steadily up the plane, $F (= \mu R)$ acts down the plane

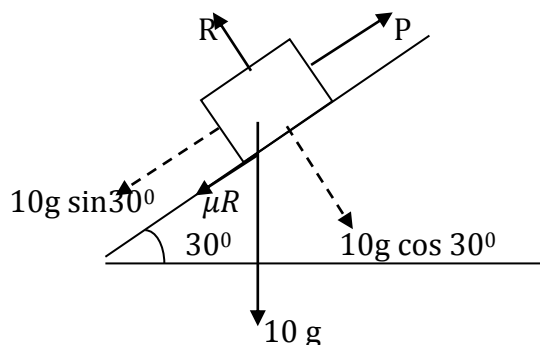

Resolving at right angle to the plane

$$R = 10g \cos 30$$

Resolving parallel to the plane

$$P = 10g \sin 30 + \mu R$$

$$P = 10 \sin 30 + 0.4 \times 10g \cos 30 .$$

$$P = 49 + 33.35$$

$$P = 82.95\text{N}$$

Example 3

A parcel of mass 2kg is placed on a rough plane which is inclined at 45° to the horizontal. The coefficient of friction between the parcel and the plane is 0.25. Find the force that must be applied to the force in the direction parallel to the plane so that

- (i) the parcel is just prevented from sliding down the plane
- (ii) The parcel is just on the point of moving up the plane
- (iii) The parcel moves up the plane with an acceleration of 1.5ms^{-2} . If it is prevented from sliding down the plane, find the frictional force that acts up the plane.

Solution

- (i) Let the force be P

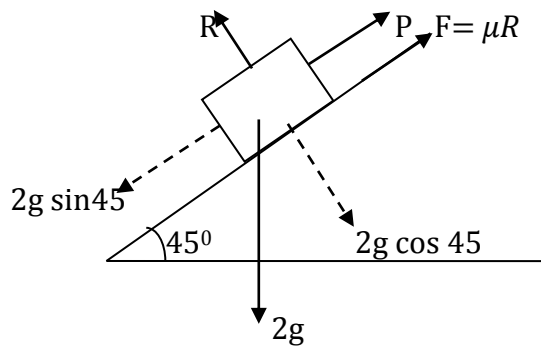

$$R = 2g \cos 45$$

Parallel to the plane;

$$P + \mu R = 2g \sin 45$$

$$P + 0.25 (2g \cos 45) = 2g \sin 45$$

$$P = 2g \sin 45 - 0.5g \cos 45$$

$$P = 10.39 \text{ N}$$

- (ii) On the point moving up the plane, the frictional force acts down the plane

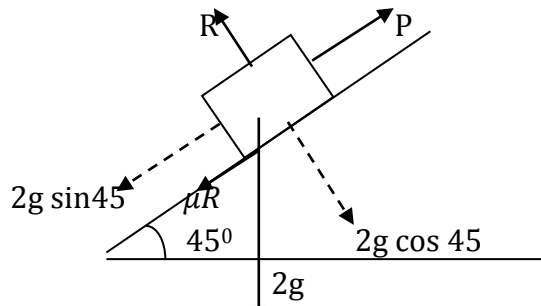

$$R = 2g \cos 45$$

$$P = 2g \sin 45 + \mu R$$

$$P = 2g \sin 45 + 0.25 (2g \cos 45)$$

$$P = 2g \sin 45 + 0.5g \cos 45$$

$$P = 13.86 + 3.46$$

$$P = 17.32 \text{ N}$$

- (iii) If the parcel moves up the plane,
then the resultant force, $F = \text{mass} \times \text{acceleration}$
Resultant force up the plane = $P - (2g \sin 45 + \mu R)$

$$\text{But } R \cdot F = ma$$

$$P - (2g \sin 45 + 0.25 \times 2g \cos 45) = 2 \times 1.5$$

$$P = 3 + 2g \sin 45 + 0.5g \cos 45$$

$$3 + 13.86 + 3.46$$

$$P = 20.32 \text{ N}$$

Trial questions

1. If a force of 10 N is just sufficient to move a mass of 2kg resting on a rough horizontal table, find the coefficient of friction [ans ; 0.51]
2. A block of mass 10kg is placed on an inclined plane of angle 30 to the horizontal where the coefficient of friction between plane and the surface is 0.5 Find

- (a) The force required to make the block begin to move up the plane
(b) Keep the block at rest
(c) Acceleration, of the block down the plane

[Ans a) 91.4N b) 6.6N c) 0.66m/s^2]

3. A block of mass of 5kg placed on an inclined plane of angle 60° to the horizontal is just at rest .Find the force parallel to the plane required to push the block up the plane of the inclination is reduced [Ans. 98N]

4.A box of mass 20kg starts from rest and slides down a slope inclined at 30° to the horizontal .If the coefficient of friction is 0.4,find the acceleration of the box

5.A particle is placed on rough plane inclined at angle θ to horizontal ,where $\tan \theta = \frac{3}{4}$ The coefficient of friction between the plane and the particle is 0.5 .The particle is rest under the action of a force F applied in an up ward direction parallel to the plane

- (a) Calculate the value of F when the particle is about to move down the plane
(b) Calculate the value of F when the particle is about to move up the plane

[Ans: a) 2 N b) 10 N]

CHAPTER 23: NEWTON'S LAWS OF MOTION**First law:**

A change in the state of motion of a body is caused by a force acting on the body otherwise.

Body at rest

If forces act on a body and does not move the forces must balance .Hence if a number of forces act on a body and it moves at rest, the resultant force in any direction must be zero

Example 1

A body is at rest when subjected to the forces on shown below .Find x and y

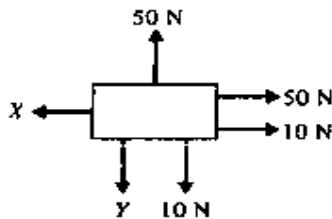
**Solution**

The horizontal forces must balance

$$X = 50 + 10$$

$$X = 60 \text{ N}$$

The vertical forces balance

$$Y + 10 = 50$$

$$Y = 40 \text{ N}$$

A body in motion

A body can only change its velocity, ie increase its speed, slow down or change direction, if a resultant force acts upon it .Thus if a body is moving with a constant velocity ,there can be no resultant force acting on it.

Example 2

A body moves horizontally at a constant speed of 5 m s^{-1} and is subjected to the forces shown .Find P and S.

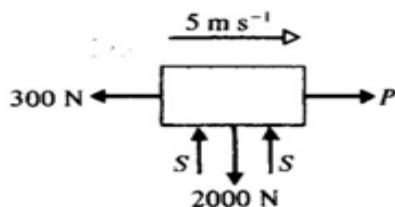

$$S + S = 2000 \text{ N}$$

$$S = 1000 \text{ N}$$

The horizontal velocity is constant

$$P = 300 \text{ N}$$

Second law

Newton's second law can be summarized by the equation $F = ma$ where f is the force on a body in mass of the body and a is the acceleration of the body produced in the direction of the applied force or resultant force.

Example 3

A body of mass 8kg is acted upon by a force of 10N . Find its acceleration.

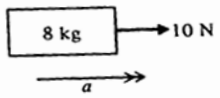
Solution

$$F = ma$$

$$10 = 8a$$

$$a = 1.25\text{ms}^{-2}$$

Example 4

Find resultant force that would give a body of mass 200g an acceleration of 10ms^{-2}

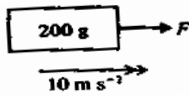
Solution

$$m = 200\text{g} = \frac{200}{1000} = 0.2\text{kg}$$

Using $F = ma$

$$F = 0.2 \times 10$$

$$F = 2\text{ N}$$

The force is 2 N

Example 5

A horizontal force of 0.6N acts on a body of mass 0.3kg . There is a resistance of 0.15N opposing the first force .What acceleration will be produced?

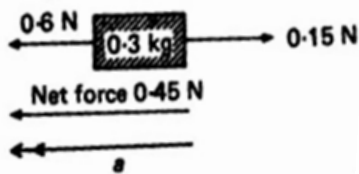
Solution

$$\text{Net force / Resultant force} = 0.6 - 0.15 = 0.45\text{N}$$

The acceleration will take place in the direction of the resultant force

$$F = ma$$

$$0.45 = 0.3a$$

$$a = 1.5\text{ms}^{-2}$$

Example 6

A car of mass 500 kg moves along a level road with an acceleration of 2ms^{-2} if it is exerting a forward force of 1100N ,what resistance is the car experiencing?

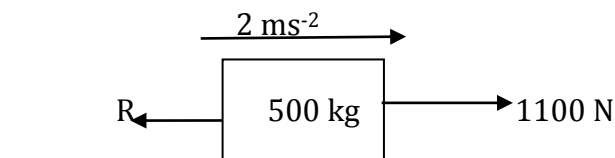

$$\text{Net force} = ma$$

$$\text{Net force} = 1100 - R$$

$$1100 - R = 500 \times 2$$

$$1100 - R = 1000$$

$$R = 100\text{N}$$

The car is experiencing a resistance of 100N

Example 7

A van of mass 2 tones moves along a level road against resistant of 700 N .If its engine is exerting a forward force of 2200N ,find the acceleration of the van.

Solution

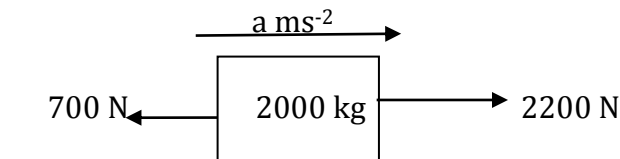

$$\text{Mass} = 2 \times 1000 \text{ kg} = 2000 \text{ kg}$$

$$\text{Net force} = ma$$

$$\text{Net force} = 2200 - 700 = 1500 \text{ N}$$

$$1500 = 2000a$$

$$a = 0.75 \text{ ms}^{-2}$$

Example 8

A box of mass 5 kg is lowered vertically by a rope .Find the force in the rope when the box is lowered with an acceleration of 4ms^{-2} .

Solution

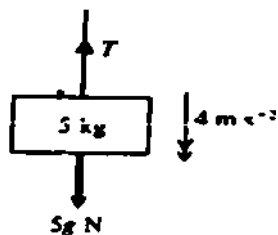

$$\text{Mass of box} = 5 \text{ kg}$$

$$\text{Weight of box} = 5g \text{ N}$$

$$\text{Resultant vertical force} = (5g - T) ; \text{down wards}$$

$$\text{Using } F = ma$$

$$5g - T = 5 \times 4$$

$$5 \times 9.8 - T = 20$$

$$T = 29 \text{ N}$$

The force in the rope is 29 N

Example 9

A pack of bricks of mass 100 kg is hoisted up the side of the house .Find the force in the lifting rope when the bricks are lifted with an acceleration of 0.25ms^{-2} .

Solution

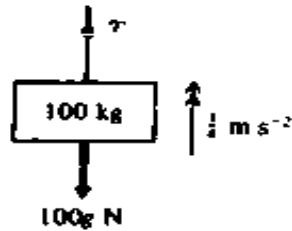

Mass of bricks = 100 kg

Weight of bricks = 100g N

The resultant upward force = $(T - 100g)$ N (since motion is upward)

$$T - 100g = 100 \times 0.25$$

$$T = 100g + 25$$

$$T = 100 \times 9.8 + 25$$

$$T = 1005 \text{ N}$$

Newton's third law

If two bodies are in contact, actually touching or connected by a string, rope or rod, they will have an effect on each other. Newton's third law states that if two bodies A and B are in contact, A will exert a force on B and B will exert an equal but opposite force on A, i.e. equal in magnitude but directed in the opposite sense along the same line.

1. Consider a box of mass M kg resting on a horizontal

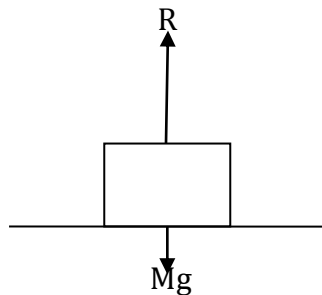

The box exerts a force on the floor and the floor reacts by exerting an equal but opposite force R

2. Consider a car pulling a caravan

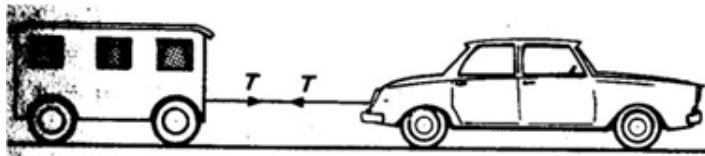

The pull of the car is transmitted through the tie rod to the caravan but the caravan equally pulls the car backwards.

3. Consider two masses suspended by a string over a frictionless (smooth) pulley

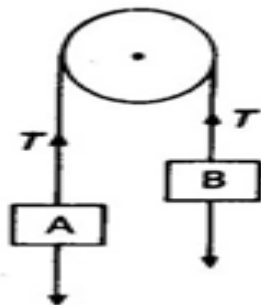

The string transmits a tension which pulls A upwards when considering A but pulls B up wards B upwards when considering B.

CONNECTED PARTICLES

Case 1

Consider a body of mass 3 kg at rest on a smooth horizontal table. This body is connected by a light string which passes over a smooth pulley at the edge of the table, to another body of mass 2 kg hanging freely.

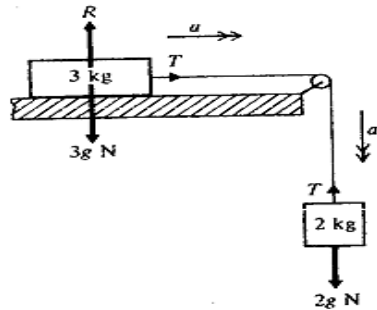

The 3 kg mass will not move in a vertical direction, so the vertical forces acting on it must balance.
 $R = 3g$

The horizontal force acting on the 3 kg mass is T.

Using $F = ma$ gives the equation of motion as:

$$T = 3a \dots\dots\dots(i)$$

The 2 kg mass moves vertically downwards

Using $F = ma$ gives the equation of motion as :

$$2g - T = 2a \dots\dots\dots(ii)$$

Solving equations (i) and (ii) simultaneously ie (i) + (ii);

$$2g = 3a + 2a$$

$$a = \frac{2}{5}g$$

$$a = 3.92 \text{ ms}^{-2}$$

Substituting for a into equation (i)

$$T = 3 \times 3.92$$

$$= 11.76 \text{ N}$$

Case 2

Particles of mass 4 kg and 2 kg are connected by a light string passing over a smooth fixed pulley . The particles hang freely and are releases from rest. Find the acceleration of the two particles and the tension in the string .

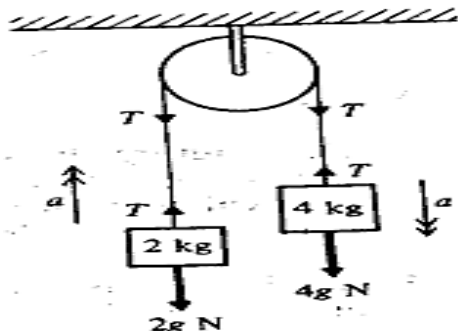

Let the acceleration be a and the tension in the string be T .

Using $F = ma$ gives;

for 2 kg : $T - 2g = 2a$ (i)

for 4 kg : $4g - T = 4a$ (ii)

adding equations (i) and (ii) gives;

$$2g = 6a$$

$$a = 3.27 \text{ ms}^{-2}$$

using (i); $T = 2a + 2g$

$$T = 2(3.27) + 2(9.8)$$

$$= 26.13 \text{ N}$$

A light inextensible string is placed over a smooth pulley. To the ends of the string are attached masses of 2 kg (A) and 1 kg (B) and both parts of the string are vertical. With what acceleration does the system move? What is the reaction at the axle of the pulley?

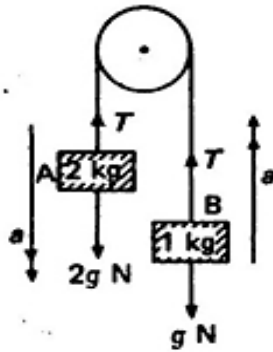

The 1kg mass accelerates upwards as the 2 kg mass accelerates downwards.

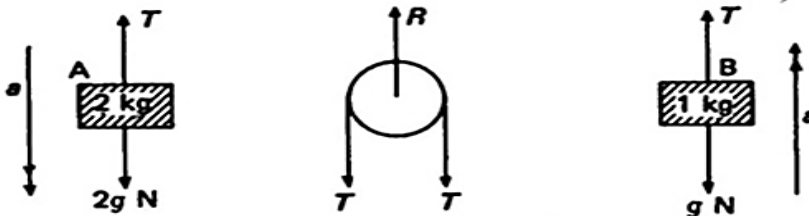

For mass A, since acceleration is downwards: $2g - T = 2a$ (i)

For mass B, acceleration upwards: $T - g = a$ (ii)

For the pulley, since it has no acceleration: $R = 2T$ (iii)

Now solve these equations for a , T and R

Equation (i) + (ii) gives;

$$g = 3a$$

$$a = 3.27 \text{ ms}^{-2}$$

From (ii) $T = a + g$

$$= 3.27 + 9.8 = 13.1 \text{ N}$$

From (iii) $R = 2T$

$$= 2(13.1) = 26.2 \text{ N}$$

Case 3

A body A rests on a smooth horizontal table. Two bodies of mass 2 kg and 10 kg, hanging freely, are attached to A by strings which pass over smooth pulleys at the edges of the table. The strings are taut. When the system is released from rest, it accelerates at 2 ms^{-2} . Find the mass of A

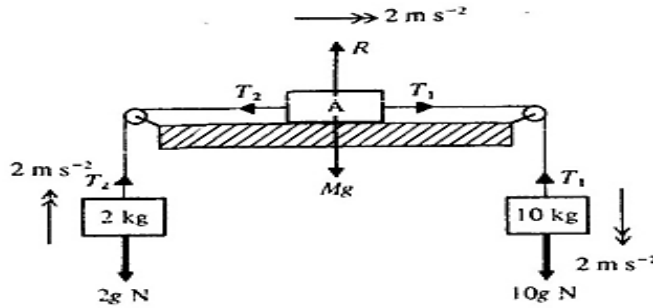

Let the mass of A be M kg. The tensions in the two strings will be different; let them be T_1 and T_2 .

Using $F = ma$ gives;

For 2 kg mass: $T_2 - 2g = 4$ (i)

For A: $T_1 - T_2 = 2M$ (ii)

For 10 kg mass: $10g - T_1 = 20$ (iii)

Adding equations (i), (ii) and (iii) gives

$$8g = 2M + 24$$

$$2M = 54.4$$

$$M = 27.2$$

The mass of the body A is 27.2 kg

Case 4

Consider three masses A, B, C connected by light inextensible strings as shown in the figure below where B is held on a rough horizontal plane whose coefficient of friction is 0.6. The pulleys are smooth.

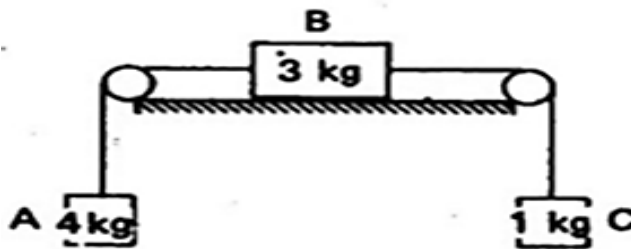

When B is released, what will be the acceleration of the masses?

Solution

The forces that act on the masses can be shown in the diagrams below

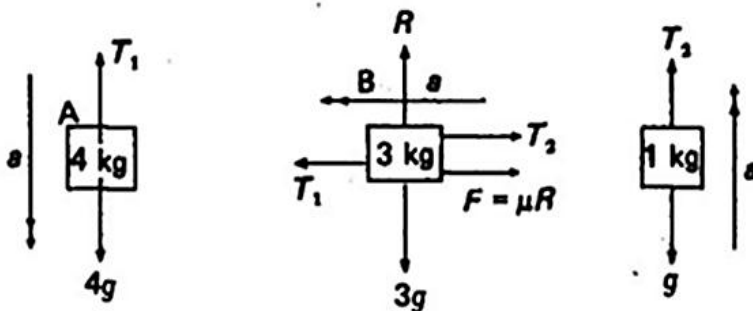

$$4g - T_1 = 4a \quad \text{.....(i)}$$

$F = \mu R$ (as B moves) and acts against the motion

$$R = 3g$$

$$F = 0.6 \times 3g = 1.8g$$

$$T_1 - (T_2 + F) = 3a \dots\dots\dots(ii)$$

$$T_2 - g = a \dots\dots\dots(iii)$$

From (i) $T_1 = 4g - 4a$

From (iii) $T_2 = g + a$

Substituting for T_1 and T_2 in (ii) gives;

$$4g - 4a - (g + a + 1.8g) = 3a$$

Which simplifies to $1.2g = 8a$

Giving $a = 1.47 \text{ ms}^{-2}$

Note: It is necessary to decide in certain problems in which direction the friction is going to act.

Case 5

The bodies shown are connected by a light string which passes over a smooth pulley. The 1 kg mass moves upwards while the 3 kg mass moves downwards. Calculate the tension T , the normal reaction R and the acceleration a .

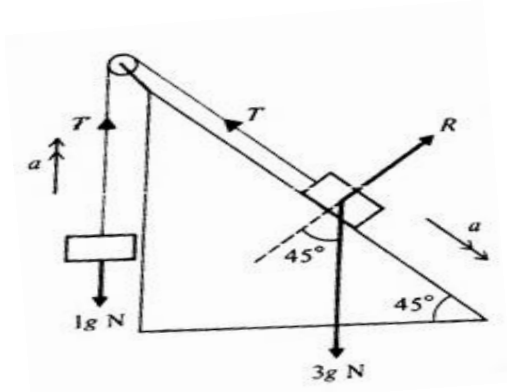

Applying $F = ma$ in a vertical direction for the 1 kg mass gives;

$$T - 1g = 1 \times a \dots\dots\dots(i)$$

Applying $F = ma$ down the plane for the 3 kg mass gives;

$$3g \sin 45^\circ - T = 3 \times a$$

$$3 \frac{\sqrt{2}}{2}g - T = 3a \dots\dots\dots(ii)$$

Adding equations (i) and (ii) ;

$$3 \frac{\sqrt{2}}{2}g - g = 4a$$

$$1.1213g = 4a$$

$$a = 2.747 \text{ ms}^{-2}$$

Substitute into equation (i);

$$T = g + 2.747$$

$$= 12.547 \text{ N}$$

Resolve at right angles to the surface of the plane, for the 3 kg mass (note that in this direction there is no acceleration)

$$R = 3g \cos 45^\circ$$

$$= 20.79 \text{ N}$$

The tension in the string is 12.5 N, the normal reaction is 20.8 N and the acceleration of both particles is 2.75 ms^{-2}

Trial questions

1. A block of mass 1 kg rests in equilibrium on a rough horizontal table under the action of a force P which acts at an angle of 30° to the horizontal as shown in the diagram below

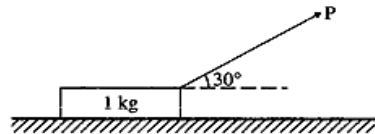

Given that the magnitude of P is 2.53 N, calculate

- (i) The normal reaction exerted by the table on the block
- (ii) The frictional force on the block

Given that the block is about to slip, calculate the coefficient of friction

[Ans: (i) 8.54 N (ii) 2.19 N ; 0.26]

2. A light inextensible string passes over a smooth fixed pulley and carries freely hanging masses of 800 g and 600 g at the ends. Find the acceleration of the system and the force on the pulley. [Ans: 1.4 ms^{-2} , 13.44 N]

3. A car of mass 900 kg tows a caravan of mass 700 kg along a level road. The engine of the car exerts a forward force of 2.4 kN and there is no resistance to motion. [Ans: 1.5 ms^{-2} , 1050 N]

4. A car of mass 900 kg tows a trailer of mass 600 kg by means of a rigid tow bar. The car experiences a resistance of 200 N and the trailer a resistance of 300 N. If the car engine exerts a forward force of 3 kN, find the tension in the tow bar and the acceleration of the system. [Ans: 1300 N, 1.67 ms^{-2}]

5. Each of the following diagrams shows two freely hanging masses connected by a light inextensible string passing over a smooth fixed pulley. For each system, find the

- (i) The acceleration of the masses
- (ii) The magnitude of the tension T_1
- (iii) The magnitude of the tension T_2

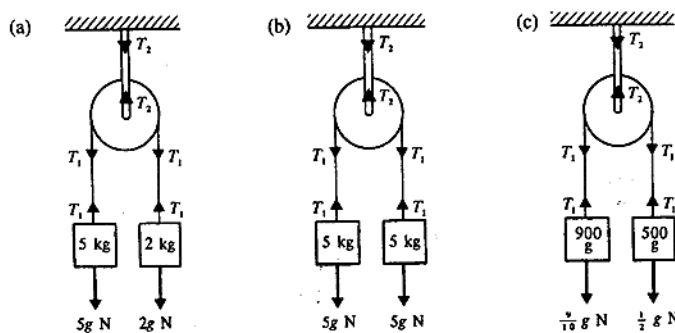

[Ans: (a) (i) 4.2 ms^{-2} (ii) 28 N (iii) 56 N (b) (i) 0 (ii) 49 N (iii) 98 N (c) (i) 2.8 ms^{-2} (ii) 6.3 N (iii) 12.6 N]

6. A body of mass 65 g lies on a smooth horizontal table. A light inextensible string runs from this body, over a smooth fixed pulley at the edge of the table to a body of mass 5 g hanging freely, With the string taut, the system is released from rest. Find

- (a) the acceleration of the system
- (b) the tension in the string
- (c) the distance moved by the 5 g mass in the first 2 seconds of motion

[Ans: (a) 0.7 ms^{-2} (b) 0.0455 N (c) 1.4 m]

7. Find the acceleration and tensions in the strings for the following systems

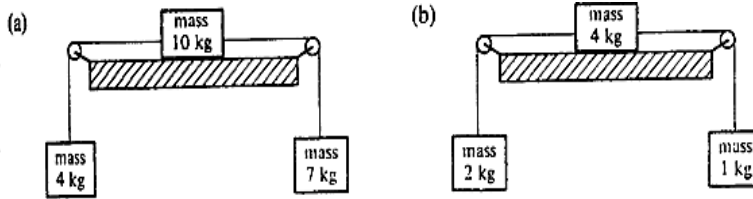

[Ans: 1.4 ms^{-2} , 44.8 N , 58.8 N (b) 1.4 ms^{-2} , 16.8 N , 11.2 N]

CHAPTER 24 : WORK, ENERGY AND POWER**WORK**

Work is defined as the (F) and the distance (S) moved in the direction of the force

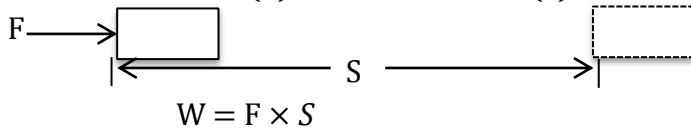

The unit of work is Joules (J)

Work done against gravity

In order to raise a mass m kg vertically at a constant speed, a force mg N must be applied vertically upwards to the mass.

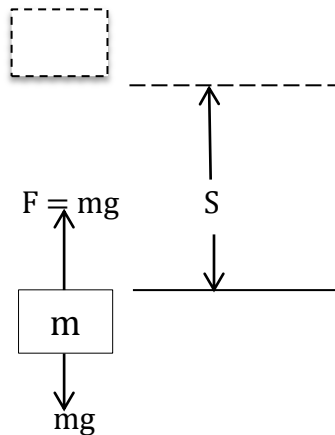

In raising the mass a distance, S metres, the work done against gravity will be given by;
Work done against gravity = mgS where g is the acceleration due to gravity

Example

Find the work done against gravity when an object of mass 3.5 kg is raised through a vertical distance of 6 m.

Solution

Vertical force required, $F = 3.5g = 3.5 \times 9.8 = 34.3$ N

And $S = 6$ m

Work done = $F \times S$

$$= 34.3 \times 6 = 205.8 \text{ J}$$

The work done against gravity is 205.8 J

General motion at constant speed

In order to move a body at a constant speed, a force equal in magnitude to the forces of resistance acting on the body has to be applied to the body.

Example 1

A block of wood is pulled a distance of 4 m across a horizontal surface against resistances totaling to 7.5 N. If the block moves at a constant velocity, find the work done against the resistances.

Solution

Let the pulling force be F

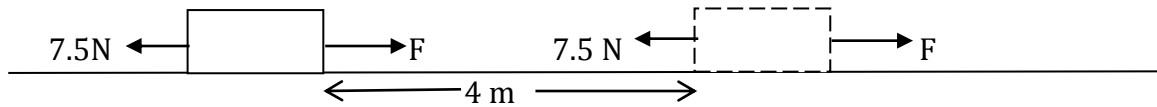

Resolving horizontally; $F = 7.5\text{ N}$

$$\begin{aligned}\text{Work done against resistances} &= \text{Force} \times \text{horizontal distance moved} \\ &= 7.5 \times 4 = 30\text{ J}\end{aligned}$$

The work done against the resistances is 30 J

Example 2

A horizontal force pulls a body of 2.25 kg a distance of 8 m across a rough horizontal surface, coefficient of friction is $\frac{1}{3}$. The body moves with a constant velocity and the only resisting force is that due to friction. Find the work done against friction

Solution

The frictional force is μR



Resolve vertically; $R = 2.25g = 2.25 \times 9.8 = 18$

$$\begin{aligned}\text{Work done against friction} &= \mu R \times \text{distance moved} \\ &= \frac{1}{3}(18) \times 8 = 58.8\text{ J}\end{aligned}$$

The work done against friction is 58.8 J

Work done against gravity and friction

When a body is pulled at a uniform speed up the surface of a rough inclined plane, work is done both against gravity and against the frictional force which is acting on the body due to the contact with the rough surface of the plane.

Example

A rough surface is inclined at $\tan^{-1}\left(\frac{7}{24}\right)$ to the horizontal. A body of mass 5 kg lies on the surface and is pulled at a uniform speed, a distance of 0.75 m up the surface by a force acting a line of greatest slope. The coefficient of friction between the body and the surface is $\frac{5}{12}$. Find;

- The work done against gravity
- The work done against friction

Solution

$$\theta = \tan^{-1}\left(\frac{7}{24}\right)$$

$$\tan \theta = \frac{7}{24}, \sin \theta = \frac{7}{25} \text{ and } \cos \theta = \frac{24}{25}$$

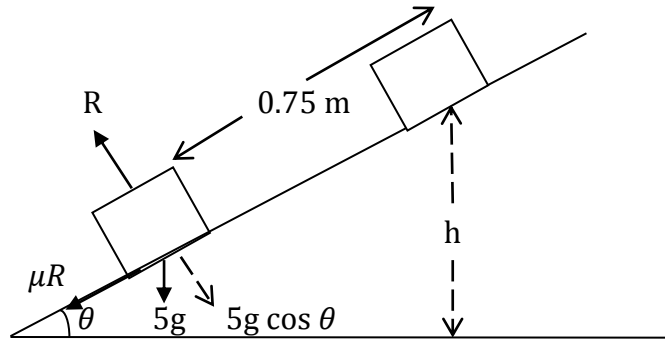

- (i) Work done against gravity = force \times vertical distance moved

$$\text{Since } \sin \theta = \frac{h}{0.75}$$

$$\text{Vertical distance moved, } h = 0.75 \sin \theta = 0.75 \times \frac{7}{25} = 0.21 \text{ m}$$

$$\text{Work done against gravity} = 5g \times 0.21 = 5 \times 9.8 \times 0.21 = 10.29 \text{ J}$$

The work done against gravity is 10.29 J

- (ii) Resolving perpendicular to the plane gives;

$$R = 5g \cos \theta = 5 \times 9.8 \times \frac{24}{25} = 47.04$$

$$\text{But frictional force} = \mu R = \frac{5}{12} \times 47.04 = 19.6 \text{ N}$$

$$\text{Work done against friction} = 19.6 \times 0.75 = 14.7 \text{ J}$$

Trial questions

- Find the work done against gravity when a body of mass 5 kg is raised through a vertical distance of 2 m. [Ans: 98 J]
- Find the work done against gravity when a body of mass 1 kg is raised through a vertical distance of 3 m. [Ans: 29.4 J]
- A body of mass 10 kg is pulled a distance of 20 m across a horizontal surface against resistances totaling to 40 N. if the body moves with uniform velocity, find the work done against the resistances. [Ans: 800 J]
- A surface is inclined at $\tan^{-1} \left(\frac{3}{4} \right)$ to the horizontal. A body of mass 50 kg lies on the surface and is pulled at a uniform speed a distance of 5 m up a line of greatest slope against resistances totaling to 50 N. find the;
 - Work done against gravity
 - Work done against the resistances [Ans: (i) 1960 J (ii) 250 J]

ENERGY

The energy of a body is a measure of the capacity which the body has to do work. When a force does work on a body, it changes the energy of a body. Energy can exist in a number of different forms, but we shall consider two main types; kinetic energy and potential energy

Kinetic energy

The kinetic energy of a body is that energy which it possesses by virtue of its motion. When a force does work on a body so as to increase its speed, then the work done is the measure of the increase in the kinetic energy of the body.

The quantity $\frac{mv^2}{2}$ is defined as the kinetic energy of mass m moving with velocity v . A body at rest therefore has zero kinetic energy.

Example 1

Find the kinetic energy of a particle of mass 0.25 kg moving with a speed of 6 m/s.

Solution

$$\begin{aligned}\text{Kinetic energy} &= \frac{1}{2}mv^2 \\ &= \frac{1}{2} \times 0.25 \times 6^2 \\ &= 4.5 \text{ J}\end{aligned}$$

The kinetic energy of the particle is 4 J

Example 2

A body of mass 4 kg decreases its kinetic energy by 32 J. If it initially had a speed of 5 m/s, find its final speed.

Solution

$$\text{Initial kinetic energy} = \frac{1}{2}mv^2 = \frac{1}{2} \times 4 \times 5^2 = 50 \text{ J}$$

$$\text{Final kinetic energy} = 50 - 32 = 18 \text{ J}$$

Let the final speed be V

$$\text{Then } \frac{1}{2}(4)V^2 = 18$$

$$V^2 = 9$$

$$V = 3 \text{ ms}^{-1}$$

The final speed of the body is 3 ms^{-1}

Example

A cricket ball of mass 400 g moving at 3 ms^{-1} and a golf ball of mass 100 g have equal kinetic energies. Find the speed at which the golf ball is moving.

Solution

$$\begin{aligned}\text{Kinetic energy of cricket ball} &= \frac{1}{2}mv^2 \\ &= \frac{1}{2}(0.4)(3)^2 = 1.8 \text{ J}\end{aligned}$$

$$\text{Kinetic energy of golf ball} = \frac{1}{2}(0.1)V^2$$

But kinetic energy of golf ball = kinetic energy of cricket ball

$$\frac{1}{2}(0.1)V^2 = 1.8$$

$$0.1V^2 = 1.8 \times 2$$

$$V^2 = \frac{3.6}{0.1} = 36$$

$$V = \sqrt{36} = 6 \text{ ms}^{-1}$$

The golf ball is moving at 6 ms^{-1}

Potential energy

The potential energy of a body is that energy it possesses by virtue of its position. When a body of mass m kg is raised vertically through a distance of h metres, the work done against gravity is mgh joules. The work done against gravity is the measure of the increase in the potential energy of the body i.e. the capacity of the body to do work is increased.

Example 1

Find the potential energy of a child of mass 48 kg when ascending a vertical distance of 2 m.

Solution

$$\begin{aligned}\text{Potential energy} &= mgh \\ &= 48 \times 9.8 \times 2 \\ &= 940.8 \text{ J}\end{aligned}$$

The potential energy is 940.8 J

Example 2

Find the potential energy gained by a ball of mass 0.075 kg at a distance of 32 m above the ground.

Solution

$$\begin{aligned}\text{Potential energy} &= mgh \\ &= 0.075 \times 9.8 \times 32 \\ &= 23.52 \text{ J}\end{aligned}$$

The potential energy is 23.52 J

Trial questions

Find the potential energy gained by;

1. A body of mass 5 kg raised through a vertical distance of 10 m
2. A man of mass 60 kg ascending a vertical distance of 5 m
3. A body of mass 20 kg above a vertical distance of 2 m from the ground.

[Ans: 1. 490 J 2. 2940 J 3. 392 J]

The principle of conservation of energy

Suppose we have a situation involving a moving body in which

- (a) There is no work done against friction, and
- (b) Gravity is the only external force which does work on the body (or against which the body has to do work)

The total mechanical energy possessed by the body will then be the total of its kinetic energy and its potential energy and by the principle of conservation of energy, this will be constant i.e.

$$\text{Total energy} = \text{kinetic energy (K.E)} + \text{potential energy}$$

Or total energy in the initial state = total energy in the final state

Example 1

The point A is vertically below the point B. A particle of mass 0.1 kg is projected from A vertically upwards with a speed of 21 ms^{-1} and passes point B with a speed of 7 ms^{-1} . Find the distance from A to B

Solution

We shall choose to measure the P.E from the level of of A. Let the distance from A to B be h metres

At A;

$$\text{K.E} = \frac{1}{2}mv^2 = \frac{1}{2}(0.1)(21)^2 = 22.05 \text{ J}$$

$$\text{P.E} = 0 \text{ J since } h = 0 \text{ at A}$$

$$\text{Total energy} = 22.05 \text{ J}$$

At B;

$$\text{K.E} = \frac{1}{2}mv^2 = \frac{1}{2}(0.1)(7)^2 = 2.45 \text{ J}$$

$$\text{P.E} = mgh = 0.1 \times 9.8 \times h = 0.98h \text{ J}$$

$$\text{Total energy} = (2.45 + 0.98h) \text{ J}$$

But from the principle of conservation of energy , total energy at A = total energy at B

$$\Rightarrow 2.45 + 0.98h = 22.05$$

$$0.98h = 22.05 - 2.45$$

$$0.98h = 19.6$$

$$h = \frac{19.6}{0.98} = 20 \text{ m}$$

The distance from A to B is 20 m

Example 2

The point A is 4 metres vertically above the point B. A body of mass 0.2 kg is projected from A vertically downwards with a speed of 3 ms^{-1} . Find the speed of the body when it reaches B

Solution

At A;

$$\text{K.E} = \frac{1}{2}mv^2 = \frac{1}{2}(0.2)(3)^2 = 0.9 \text{ J}$$

$$\text{P.E} = mgh = 0.2 \times 9.8 \times 4 = 7.84 \text{ J}$$

$$\text{Total energy at A} = 0.9 + 7.84 = 8.74 \text{ J}$$

At B;

$$\text{K.E} = \frac{1}{2}mv^2 = \frac{1}{2}(0.2)V^2 = 0.1V^2$$

$$\text{P.E} = 0$$

$$\text{Total energy} = 0.1V^2$$

Thus using the principle of conservation of energy; $0.1V^2 = 8.74$

$$V^2 = 87.4$$

$$V = \sqrt{87.4} = 9.34879$$

The speed of the body is 9.35 ms^{-1} when it reaches B

Trial questions

1. A body of mass 6 kg is released from rest and falls freely under gravity. Find the distance it has fallen when its speed is 7ms^{-1} .
2. A body of mass 20 kg is projected vertically downwards from a point A with speed 4ms^{-1} . The body passes through a point B, 5 m below A. Find the speed of the body at B.
3. A body of mass 5 kg is released from rest and falls freely under gravity. Find its speed when it has fallen a distance of 10 m.

[Ans: 1. 2.5 m 2. 10.68ms^{-1} 3. 14ms^{-1}]

POWER

Power is a measure of the rate at which work is being done. If 1 joule of work is done in 1 second, the rate of working is 1 Watt(W). Thus the unit of power is Watts (W)

$$\text{Power} = \frac{\text{workdone}}{\text{time taken}} = \frac{\text{Force} \times \text{distance}}{\text{time taken}} = \text{force} \times \frac{\text{distance}}{\text{time taken}} = \text{force} \times \text{velocity}$$

Example 1

Find the workdone by a force of 6 N in moving a body from A to B where $AB = 10\text{m}$ and also the average rate at which the force is working if it takes 5 seconds to move the body from A to B .

Solution

$$\begin{aligned} \text{Workdone by force} &= \text{force} \times \text{distance} \\ &= 6 \times 10 = 60 \text{ J} \end{aligned}$$

$$\begin{aligned} \text{Rate of working/Power} &= \frac{\text{workdone}}{\text{time taken}} \\ &= \frac{60}{5} = 12 \text{ W} \end{aligned}$$

The force does 60 J of work and its average rate of working is 12 watts

Example 2

Find the rate at which work is being done when a mass of 20 kg is lifted vertically at a constant speed of 5ms^{-1} .

Solution

$$\text{Work done} = \text{force} \times \text{distance}$$

But for body vertically above the ground, force = weight = mg

$$\text{Force} = 20 \times 9.8 = 196 \text{ N}$$

$$\begin{aligned} \text{Rate of doing work} &= \text{force} \times \text{velocity} \\ &= 196 \times 5 = 980 \text{ W} \end{aligned}$$

The rate at which work is being done is 980 W.

Trial questions

1. What is the rate at which work must be done in lifting a mass of 500 kg vertically at a constant speed of 3ms^{-1} ?
2. What is the average rate at which work must be done in lifting a mass of 100 kg a vertical distance of 5 m in 7 seconds?

[Ans: 1. 14700 W 2. 700 W]

BINOMIAL PROBABILITIES (DISTRIBUTION) $B(n,x)$, INDIVIDUAL TERMS Pr

n	r	x										
		0.01	0.05	0.10	0.15	0.20	0.25	0.30	0.35	0.40	0.45	0.50
2	0	0.9801	9025	8100	7225	6400	5625	4900	4225	3600	3025	2500
	1	0.0198	0950	1800	2550	3200	3750	4200	4550	4800	4950	5000
	2	0.0001	0025	0100	0225	0400	0625	0900	1225	1600	2025	2500
3	0	0.9703	8574	7290	6141	5120	4219	3430	2746	2160	1664	1250
	1	0.0294	1354	2430	3251	3840	4219	4410	4436	4320	4084	3750
	2	0.0003	0071	0270	0574	0960	1406	1890	2389	2880	3341	3750
	3		0001	0010	0034	0080	0156	0270	0429	0640	0911	1250
4	0	0.9606	8145	6561	5220	4096	3164	2401	1785	1296	0915	0625
	1	0.0388	1715	2916	3685	4096	4219	4116	3845	3456	2995	2500
	2	0.0006	0135	0486	0975	1536	2109	2646	3105	3456	3675	3750
	3		0005	0036	0115	0256	0469	0756	1115	1536	2005	2500
	4			0001	0005	0016	0039	0081	0150	0256	0410	0625
5	0	0.9510	7738	5905	4437	3277	2373	1681	1160	0778	0503	0312
	1	0.0480	2036	3280	3915	4096	3955	3602	3124	2592	2059	1562
	2	0.0010	0214	0729	1382	2048	2637	3087	3364	3456	3369	3125
	3		0011	0081	0244	0512	0879	1323	1811	2304	2757	3125
	4			0004	0022	0064	0146	0284	0488	0768	1128	1562
	5				0001	0003	0010	0024	0053	0102	0185	0312
6	0	0.9415	7351	5314	3771	2621	1780	1176	0754	0467	0277	0156
	1	0.0571	2321	3543	3993	3932	3560	3025	2437	1866	1359	0938
	2	0.0014	0305	0984	1762	2458	2966	3241	3280	3110	2780	2344
	3		0021	0146	0415	0819	1318	1852	2355	2765	3032	3125
	4		0001	0012	0055	0154	0330	0595	0951	0382	1861	2344
	5			0001	0004	0015	0044	0102	0205	0369	0609	0938
	6					0001	0002	0007	0018	0041	0083	0156
7	0	0.9321	6983	4783	3206	2097	1335	0824	0490	0280	0152	0078
	1	0.0659	2573	3720	3960	3670	3115	2471	1848	1306	0872	0547
	2	0.0020	0406	1240	2097	2753	3115	3177	2985	2613	2140	1641
	3		0036	0230	0617	1147	1730	2269	2679	2903	2918	2734
	4		0002	0026	0109	0287	0577	0972	1442	1935	2388	2734
	5			0002	0012	0043	0115	0250	0466	0774	1172	1641
	6				0001	0004	0013	0036	0084	0172	0320	0547
	7						0001	0002	0006	0016	0037	0078
8	0	0.9227	6634	4305	2725	1678	1001	0576	0319	0168	0084	0039
	1	0.0746	2793	3826	3847	3355	2670	1977	1373	0896	0548	0312
	2	0.0026	0515	1488	2376	2936	3115	2965	2587	2090	1569	1094
	3	0.0001	0054	0331	0839	1468	2076	2541	2786	2787	2568	2188
	4		0004	0046	0185	0459	0865	1361	1875	2322	2627	2734
	5			0004	0026	0092	0231	0467	0808	1239	1719	2188
	6				0002	0011	0038	0100	0217	0413	0703	1094
	7					0001	0004	0012	0033	0079	0164	0312
	8							0001	0002	0007	0017	0039
9	0	0.9135	6302	3874	2316	1342	0751	0404	0207	0101	0046	0020
	1	0.0830	2985	3874	3679	3020	2253	1556	1004	0605	0339	0176
	2	0.0034	0629	1722	2597	3020	3003	2668	2162	1612	1110	0703
	3	0.0001	0077	0446	1069	1762	2336	2668	2716	2508	2119	1641
	4		0006	0074	0283	0661	1168	1715	2194	2508	2600	2461
	5			0008	0050	0165	0389	0735	1181	1672	2128	2461
	6			0001	0006	0028	0087	0210	0424	0743	1160	1641
	7					0003	0012	0039	0098	0212	0407	0703
	8						0001	0004	0013	0035	0083	0176
	9								0001	0003	0008	0020
10	0	0.9044	5987	3487	1969	1074	0563	0282	0135	0060	0025	0010
	1	0.0914	3151	3874	3474	2684	1877	1211	0725	0403	0207	0098
	2	0.0042	0746	1937	2759	3020	2816	2335	1757	1209	0763	0439
	3	0.0001	0105	0574	1298	2013	2503	2668	2522	2150	1665	1172
	4		0010	0112	0401	0881	1460	2001	2377	2508	2384	2051
	5		0001	0015	0085	0264	0584	1029	1536	2007	2340	2461
	6			0001	0012	0055	0162	0368	0689	1115	1596	2051
	7				0001	0008	0031	0090	0212	0425	0746	1172

Where a space in the table is empty the probability is less than 0.00005.

BINOMIAL PROBABILITIES (DISTRIBUTION) $B(n,x)$, INDIVIDUAL TERMS Pr

n	r	x										
		0.01	0.05	0.10	0.15	0.20	0.25	0.30	0.35	0.40	0.45	0.50
10	8					0001	0004	0014	0043	0106	0229	0439
	9							0001	0005	0016	0042	0098
	10									0001	0003	0010
11	0	0.8953	5688	3138	1673	0859	0422	0198	0088	0036	0014	0005
	1	0.0995	3293	3835	3248	2362	1549	0932	0518	0266	0125	0054
	2	0.0050	0867	2131	2866	2953	2581	1998	1395	0887	0513	0269
	3	0.0002	0137	0710	1517	2215	2581	2568	2254	1774	1259	0806
	4		0014	0158	0536	1107	1721	2201	2428	2365	2060	1611
	5		0001	0025	0132	0388	0803	1321	1830	2207	2360	2256
	6			0003	0023	0097	0268	0566	0985	1471	1931	2256
	7				0003	0017	0064	0173	0379	0701	1128	1611
	8					0002	0011	0037	0102	0234	0462	0806
	9						0001	0005	0018	0052	0126	0269
	10								0002	0007	0021	0054
11										0002	0005	
12	0	0.8864	5404	2824	1422	0687	0317	0138	0057	0022	0008	0002
	1	0.1074	3413	3766	3012	2062	1267	0712	0368	0174	0075	0029
	2	0.0060	0988	2301	2924	2835	2323	1678	1088	0639	0339	0161
	3	0.0002	0173	0852	1720	2362	2581	2397	1954	1419	0923	0537
	4		0021	0213	0683	1329	1936	2311	2367	2128	1700	1208
	5		0002	0038	0193	0532	1032	1585	2039	2270	2225	1934
	6			0005	0040	0155	0401	0792	1281	1766	2124	2256
	7				0006	0033	0115	0291	0591	1009	1489	1934
	8				0001	0005	0024	0078	0199	0420	0762	1208
	9					0001	0004	0015	0048	0125	0277	0537
	10							0002	0008	0025	0068	0161
	11								0001	0003	0010	0029
12										0001	0002	
15	0	0.8601	4633	2059	0874	0352	0134	0047	0016	0005	0001	
	1	0.1303	3658	3432	2312	1319	0668	0305	0126	0047	0016	0005
	2	0.0092	1348	2669	2856	2309	1559	0916	0476	0219	0090	0032
	3	0.0004	0307	1285	2184	2501	2252	1700	1110	0634	0318	0139
	4		0049	0428	1156	1876	2252	2186	1792	1268	0780	0417
	5		0006	0105	0449	1032	1651	2061	2123	1859	1404	0916
	6			0019	0132	0430	0917	1472	1906	2066	1914	1527
	7			0003	0030	0138	0393	0811	1319	1771	2013	1964
	8				0005	0035	0131	0348	0710	1181	1647	1964
	9				0001	0007	0034	0116	0298	0612	1048	1527
	10					0001	0007	0030	0096	0245	0515	0916
	11						0001	0006	0024	0074	0191	0417
	12							0001	0004	0016	0052	0139
	13								0001	0003	0010	0032
14										0001	0005	
20	0	0.8179	3585	1216	0388	0115	0032	0008	0002			
	1	0.1652	3774	2702	1368	0576	0211	0068	0020	0005	0001	
	2	0.0159	1887	2852	2293	1369	0669	0278	0100	0031	0008	0002
	3	0.0010	0596	1901	2428	2054	1339	0716	0323	0123	0040	0011
	4		0133	0898	1821	2182	1897	1304	0738	0350	0139	0046
	5		0022	0319	1028	1746	2023	1789	1272	0746	0365	0148
	6		0003	0089	0454	1091	1686	1916	1712	1244	0746	0370
	7			0020	0160	0545	1124	1643	1844	1659	1221	0739
	8			0004	0046	0222	0609	1144	1614	1797	1623	1201
	9			0001	0011	0074	0271	0654	1158	1597	1771	1602
	10				0002	0020	0099	0308	0686	1171	1593	1762
	11					0005	0030	0120	0336	0710	1185	1602
	12					0001	0008	0039	0136	0355	0727	1201
	13						0002	0010	0045	0146	0366	0739
	14							0002	0012	0049	0150	0370
	15								0003	0013	0049	0148
	16									0003	0013	0046
	17										0002	0011
18											0002	

If the probability of success in a single trial is x the probability Pr of exactly r successes in n independent trials is given by the binomial or Bernoulli distribution $B(n, x_p)$:

$$Pr = \binom{n}{r} x^r (1-x)^{n-r}$$

CUMULATIVE NORMAL DISTRIBUTION $P(z)$											ADD										
Z	0	1	2	3	4	5	6	7	8	9	1	2	3	4	5	6	7	8	9		
0.0	0.0000	0040	0080	0120	0160	0199	0239	0279	0319	0359	4	8	12	16	20	24	28	32	36		
0.1	0.0398	0438	0478	0517	0557	0596	0636	0675	0714	0753	4	8	12	16	20	24	28	32	36		
0.2	0.0793	0832	0871	0910	0948	0987	1026	1064	1103	1141	4	8	12	15	19	22	27	31	35		
0.3	0.1179	1217	1255	1293	1331	1368	1406	1443	1480	1517	4	8	11	15	19	22	26	30	34		
0.4	0.1554	1591	1628	1664	1700	1736	1772	1808	1844	1879	4	7	11	14	18	22	25	29	32		
0.5	0.1915	1950	1985	2019	2054	2088	2123	2157	2190	2224	3	7	10	14	17	21	24	27	31		
0.6	0.2257	2291	2324	2357	2389	2422	2454	2486	2517	2549	3	6	10	13	16	19	23	26	29		
0.7	0.2580	2611	2642	2673							3	6	9	12	15	19	22	25	28		
0.8	0.2881	2910	2939	2967	2704	2734	2764	2794	2823	2852	3	6	9	12	15	18	21	24	27		
0.9	0.3159	3186	3212	3238	2995	3023		3051	3078	3106	3133	3	5	8	11	13	16	19	22	24	
1.0	0.3413	3438	3461	3485	3264	3289		3315	3340	3365	3389	2	5	7	10	12	15	17	20	22	
1.1	0.3643	3665	3686	3708			3508	3531	3554	3577	3599	3621	2	4	7	9	11	13	15	18	20
1.2	0.3849	3869	3888	3907	3729	3749	3770	3790	3810	3830			2	4	6	8	10	12	14	16	18
1.3	0.4032	4049	4066	4082	3925		3944	3962	3980	3997	4015			2	4	5	7	9	11	13	14
1.4	0.4192	4207	4222	4236	4099	4115	4131	4147	4162	4177			2	3	5	6	8	10	11	13	14
1.5	0.4332	4345	4357	4370	4251	4265	4279	4292	4306	4319			1	3	4	6	7	8	10	11	13
1.6	0.4452	4463	4474	4484	4382	4394	4406	4418	4429	4441			1	2	4	5	6	7	8	10	11
1.7	0.4554	4564	4573	4582	4495	4505	4515	4525	4535	4545			1	2	3	4	5	6	7	8	9
1.8	0.4641	4649	4656	4664	4591	4599	4608	4616	4625	4633			1	2	3	3	4	5	6	7	8
1.9	0.4713	4719	4726	4732	4671	4678	4686	4693	4699	4706			1	1	2	3	4	4	5	6	6
2.0	0.4772	4778	4783	4788	4738	4744	4750	4756	4761	4767			1	1	2	2	3	4	5	5	5
2.1	0.4821	4826	4830	4834	4793	4798	4803	4808	4812	4817			0	1	1	2	2	3	3	4	4
2.2	0.4861	4864	4868	4871	4838	4842	4846	4850	4854	4857			0	1	1	2	2	2	3	3	4
2.3	0.4893	4896	4898	4901	4875	4878	4881	4884	4887	4890			0	1	1	1	2	2	2	3	3
2.4	0.4918	4920	4922	4925	4893	4896	4900	4909	4911	4913			0	0	1	1	1	2	2	2	2
2.5	0.4938	4940	4941	4943	4927	4929	4931	4932	4934	4936			0	0	1	1	1	1	1	2	2
2.6	0.4953	4955	4956	4957	4945	4946	4948	4949	4951	4952											
2.7	0.4965	4966	4967	4968	4959	4960	4961	4962	4963	4964											
2.8	0.4974	4975	4976	4977	4969	4970	4971	4972	4973	4974											
2.9	0.4981	4982	4982	4983	4977	4978	4979	4979	4980	4981											
3.0	0.4987	4990	4993	4995	4984	4984	4985	4985	4986	4986											
					4997	4998	4998	4999	4999	5000											

The table gives $P(z) = \int_0^z \phi(z) dz$

If the random variable Z is distributed as the standard normal distribution N(0,1) then:

- $P(0 < Z < z_p) = P(\text{Shaded Area})$
- $P(Z > z_p) = Q = \frac{1}{2} - P$
- $P(Z > |Z_p|) = 1 - 2P = 2Q$

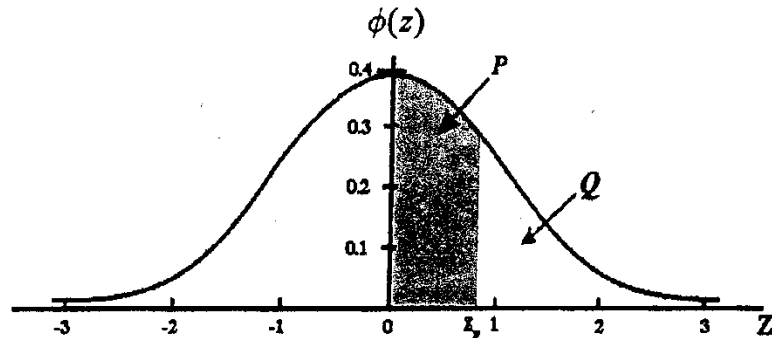

REFERENCES

Backhouse, J.K. (2011), Pure Mathematics, Pearson Education Limited, International, Harlow

S. Chandler, L. Bostock (1996), Mechanics and Statistics for Advanced Level

Smedley, R. and Wiseman, G. (1998), Introducing Pure Mathematics, Oxford University Press.

Thorning, A. J. and D.W.S. (1996), Understanding Mechanics, Oxford University Press, United Kingdom

Thorning, A.J. and D.W.S. (1996), Understanding Pure Mathematics, Oxford University Press, United Kingdom

J. Crawshaw and J. Chambers, A concise course in Advanced Level Statistics, Fourth Edition, Nelson Thornes

Core Mathematics for Advanced Level by L. Bostock and S.Chandler

Understanding statistics by Graham Upton and Ian Cook

A comprehensive Approach to Advanced level Statistics and Numerical Methods by Mukose Muhammad, Third Edition.