

ELECTRO-MAGNETISM

MAGNETIC EFFECT OF AN ELECTRIC CURRENT:

When current flows in a wire, a magnetic field is created around the wire.

The direction of magnetic field created is determined by the direction of current.

- ❖ If a straight vertical wire passing through the center of a card board held horizontally with iron fillings and current is passed through the wire, iron fillings sprinkled on the card board make concentric circles when the board is tapped.

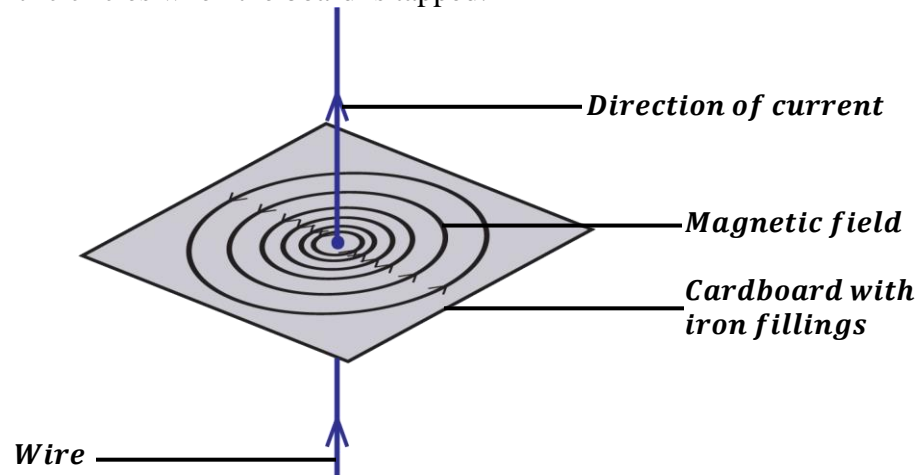

Experiment to show magnetic effect of an electric current using a compass needle.

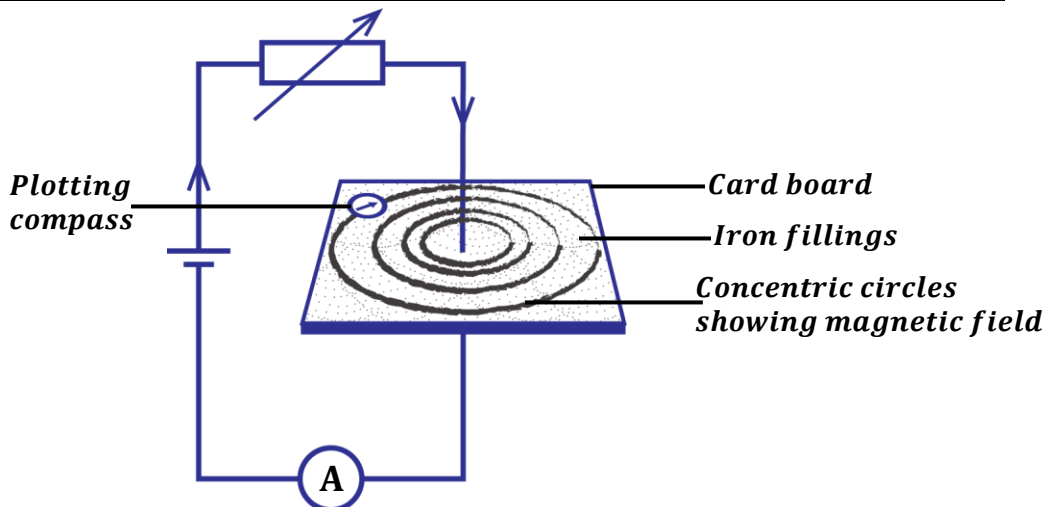

- A card board is held horizontally with a vertical copper wire passing through the centre of the card board.
- Iron fillings are sprinkled all over the card board and current is switched on.
- The card board is tapped and the iron fillings arrange themselves in series of concentric circles. This shows that a magnetic field has been created around the wire.
- A plotting compass is placed at different positions around the wire on the card board to determine the direction of magnetic field.



NOTE: The concentric circles are close to each other near the wire showing that magnetic force is stronger near the wire.

DIRECTION OF MAGNETIC FIELD AND CURRENT

The direction of the magnetic field around the wire can be determined by the following rules.

Right hand grip rule:

It states that if a wire is held in the right hand with the thumb pointing in the direction of current then the other fingers point in the direction of magnetic field.

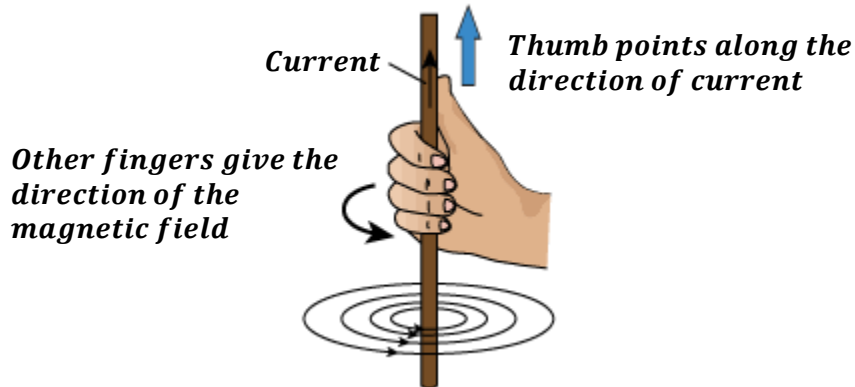

Maxwell's cork-screw rule:

It states that if the right hand is used to screw a screw a cork-screw along the wire in the direction of current, the direction of rotation of the screw gives the direction of magnetic field.

The direction of rotation gives the direction of the magnetic field

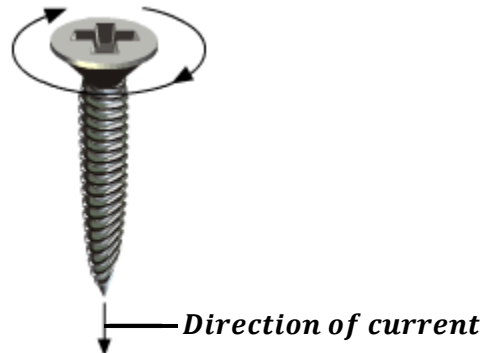

MAGNETIC FIELD PATTERN DUE TO A STRAIGHT WIRE CARRYING CURRENT.

(a) **Straight wire carrying current into a paper:**

We use a cross 

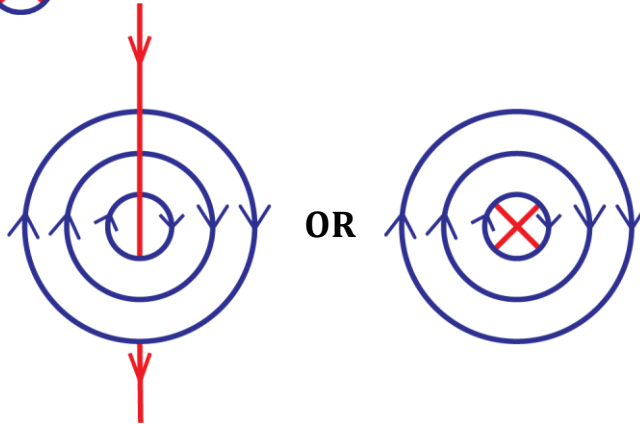

(b) **Straight carrying current out of paper:**

We use a dot 

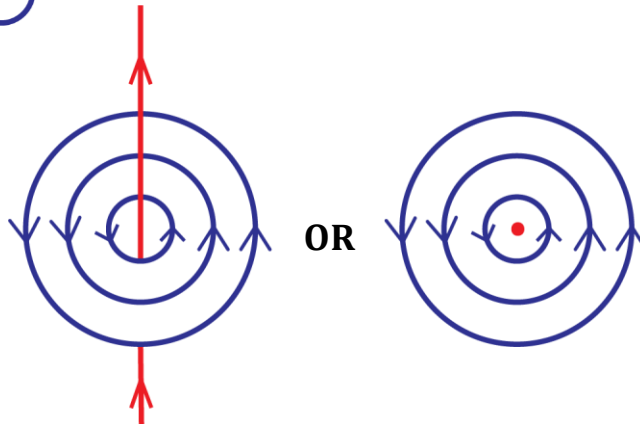

(c) **Two straight wires carrying current in the same direction:**

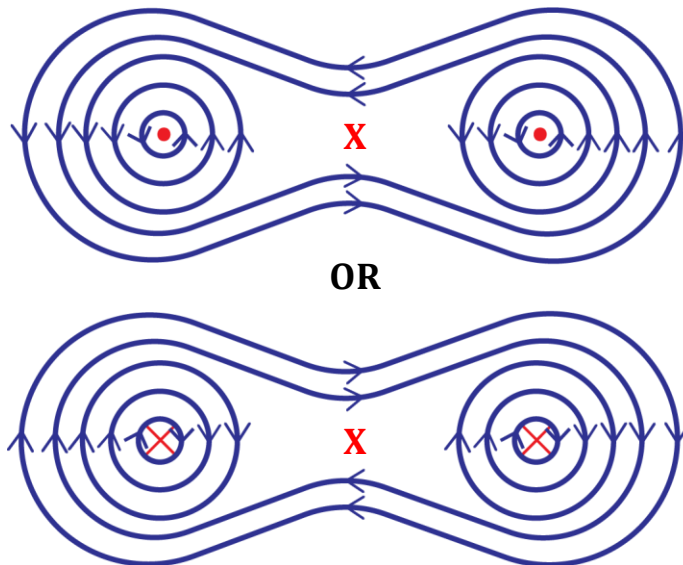

(d) Two straight wires carrying current in opposite directions:

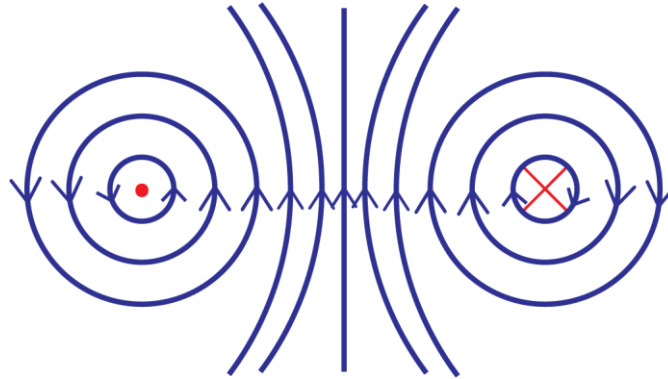

(e) Current due to a circular coil:

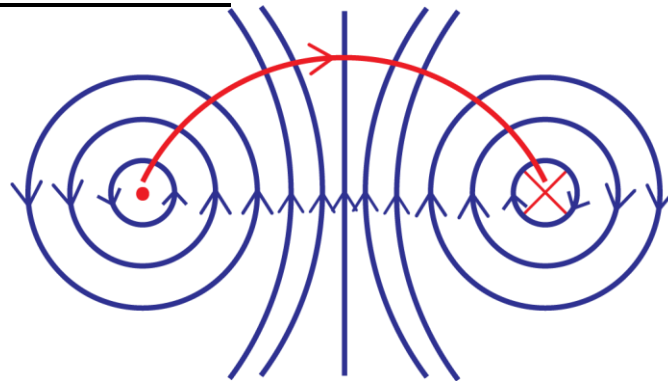

(f) Current due to a circular coil:

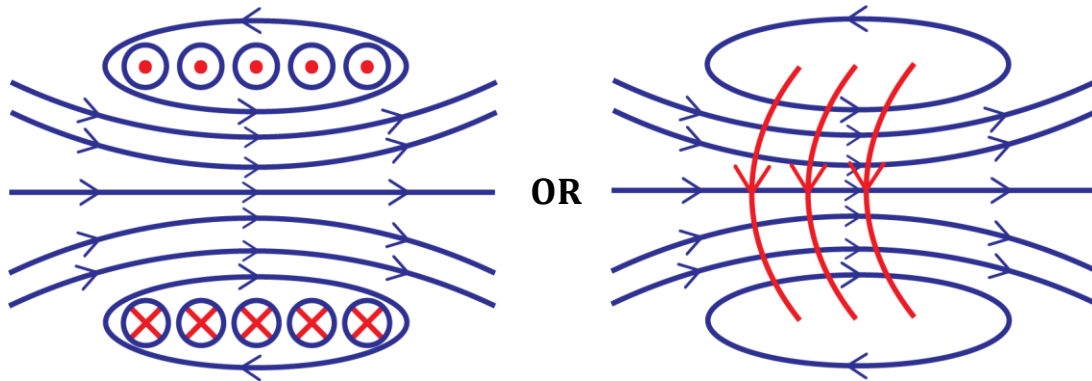

ELECTRO-MAGNETS

If a piece of iron is placed inside a solenoid, it becomes strongly magnetized when the current is flowing. When current is switched off, the iron loses its magnetism. Such a device is called an electromagnet.

Definition:

An electromagnet is a magnet produced when a magnetic material is placed in a solenoid carrying current.

Factors that affect the strength of an electromagnet:

- ❖ **Number of turns of the solenoid:**
Increasing the number of turns of the solenoid increases the strength of the electromagnet.
- ❖ **Amount of current flowing in the solenoid:**
Increasing the current flowing in the solenoid increases the strength the electromagnet.
- ❖ **Nature of magnetic material used:**
If soft iron is used, it has much strength because iron is easily magnetized and easily demagnetized.
- ❖ **Shape of magnetic material used:**
If the poles of the magnetic material are close to each other the electromagnet produced is stronger. A horse-shoe magnet produces a stronger electromagnet.

APPLICATIONS OF ELECTROMAGNETS

Electromagnets are frequently used in the following devices.

- Lifting magnets.
- Electric bells.
- Telephone receiver.
- Moving coil loud speaker.
- Magnetic relays.

LIFTING MAGNETS:

In steel industries, electromagnets are used for lifting and transporting heavy steel from one place to another in a factory.

The electromagnets are made of several coils of an insulated copper wire wound on a U-shaped soft iron so that an opposite polarity is produced.

The opposite adjacent poles increase the lifting power of the electromagnet.

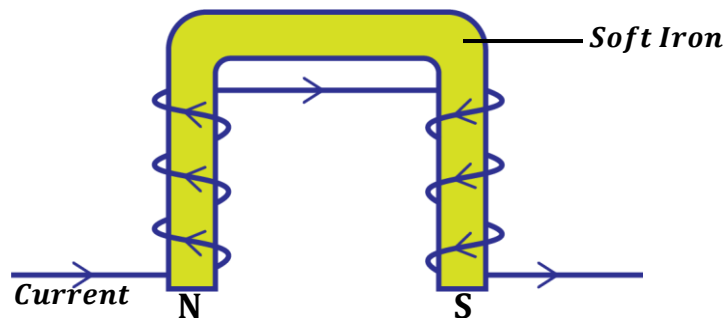

ELECTRIC BELL:
Structure:

It consists of a hammer, a gong, soft iron armature, contact adjusting screw, a push switch, steel spring and an electromagnet made of two coils wound in opposite directions on the iron cores.

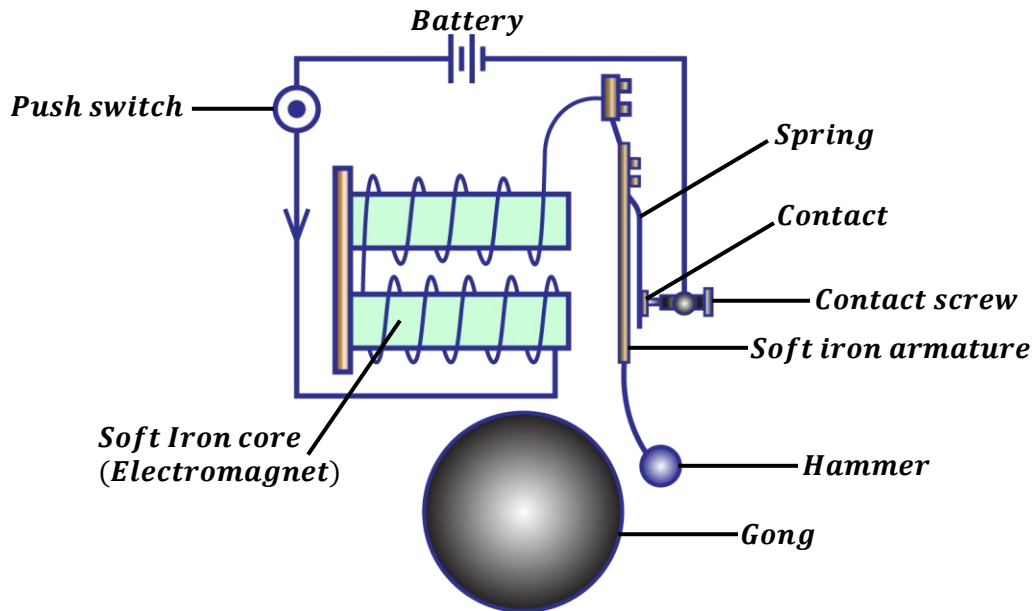
Mode of operation of an electric bell:

- When the switch is pressed, current flows in the circuit and magnetizes the soft iron core which becomes an electromagnet.
- The electromagnet attracts the soft iron armature which makes the hammer to hit the gong and a loud sound is heard.
- As the armature is attracted, the contact between the spring and the contact screw is broken thus cutting off the current.
- The electromagnet loses its magnetism and the spring returns back to its original position and makes the contact again.
- The process is repeated and the hammer hits the gong repeatedly making continuous ringing.

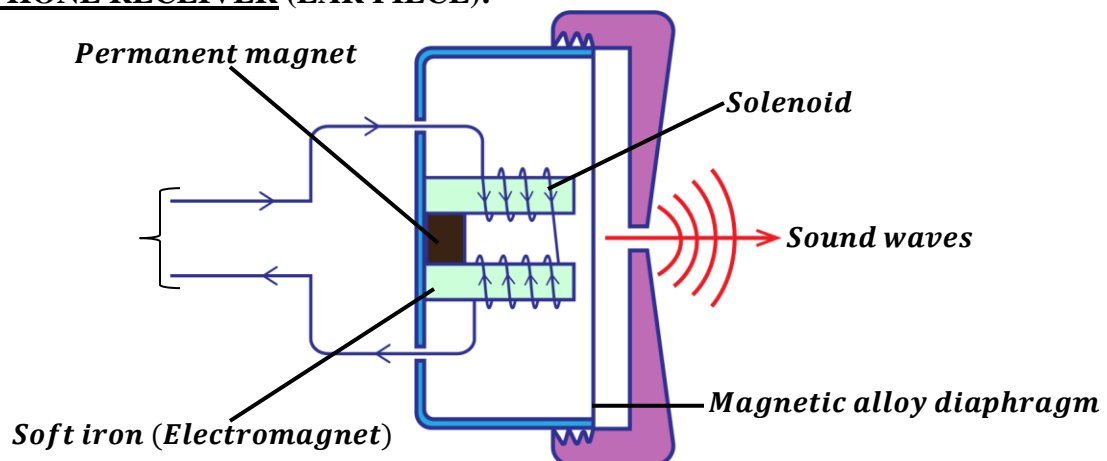
TELEPHONE RECEIVER (EAR PIECE):

- When a person speaks into a telephone microphone, sound energy is converted into electric current. The current produced is varying and has the same frequency as the sound from the person.
- When the current passes through the solenoid in the telephone receiver, the soft iron (electromagnet) is magnetized.
- The electromagnet produces a corresponding variation in the pull of the diaphragm.
- The diaphragm then vibrates and reproduces a copy of the sound produced by the person through the microphone.



MAGNETIC RELAY:

A magnetic relay is a switch which uses a small current in a primary circuit to turn on or off a larger current in the secondary circuit.

They are used in telephone circuits, traffic light circuits etc.

Mode of operation of a magnetic relay:

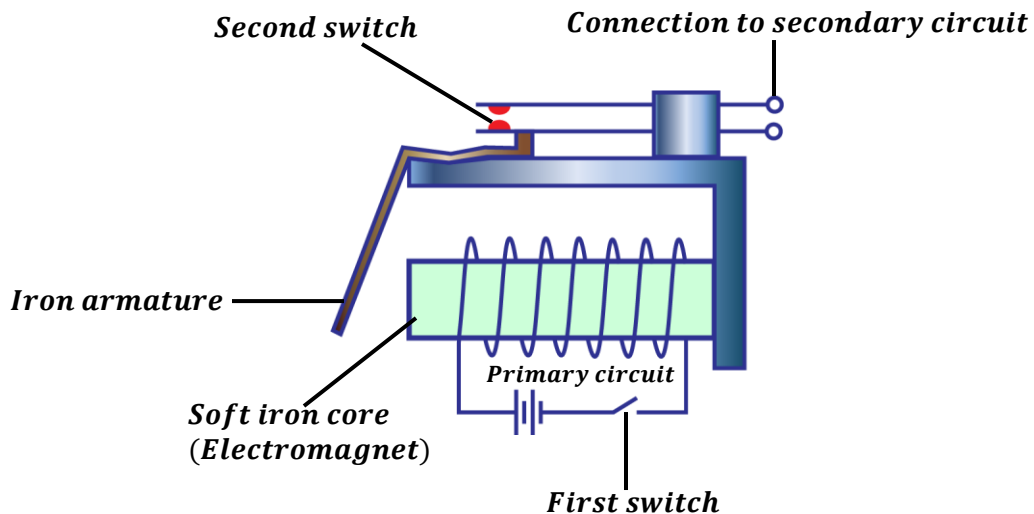

- The primary circuit supplies current to the soft iron (electromagnet).
- The soft iron gets magnetized and it then attracts the iron armature.
- As the armature is attracted, the contacts of the second switch are closed and current flows to the secondary circuit.
- When current in the primary circuit is switched off, the electromagnet loses its magnetism. This makes the iron armature to return back to its original position thus making the contacts of the second switch to become open again



CIRCUIT BREAKER:

This is an automatic switch that cuts off current in the circuit when current become too much.

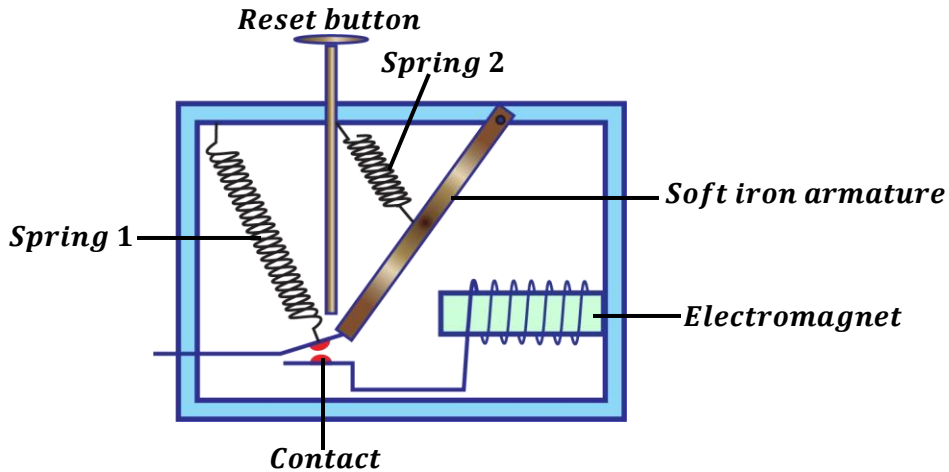

When current in the circuit increases, the strength of the electromagnet will also increase thus pulling the soft iron armature towards the electromagnet. As a result, spring 1 pulls the contact apart and disconnects the circuit immediately and current stops to flow. The circuit can be reconnected back using a reset button by pushing down in order to bring the contacts together.

**FORCE ON A CONDUCTOR CARRYING CURRENT IN A MAGNETIC FIELD
(MOTOR EFFECT)**

When a conductor carrying current is placed across a magnetic field, it experiences a force

How a force on a current carrying conductor occurs:

A magnetic field exists around a conductor carrying current. Therefore, when a conductor carrying current is placed across a magnetic field of a permanent magnet, the magnetic field due to the current in the conductor interacts with the magnetic field due to the permanent magnet. This interaction results in a force being produced on the conductor.

Magnetic field due to permanent magnet

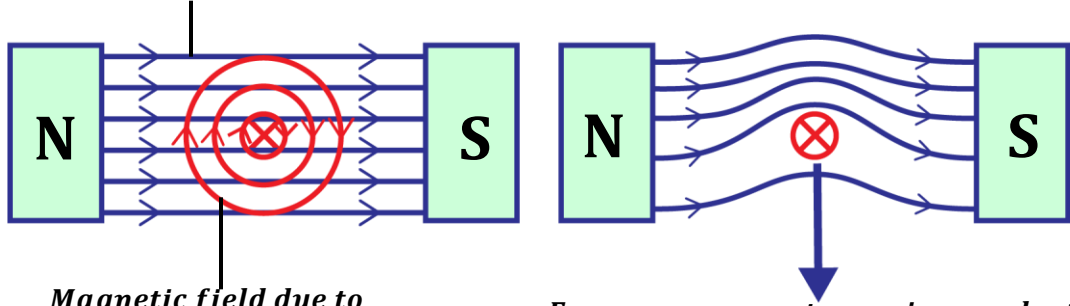

Magnetic field due to current carrying conductor

Force on a current carrying conductor

(a) Individual magnetic fields

(b) Combined magnetic fields



DIRECTION OF FORCE:

The direction of force exerted on a conductor can be found by using Fleming's left hand rule.

Fleming's left hand rule;

It states that if the left hand is held with the thumb, first finger and second finger placed at right angles to each other, the thumb points in the direction of force, the first finger points in the direction of magnetic field and second finger points in the direction of current.

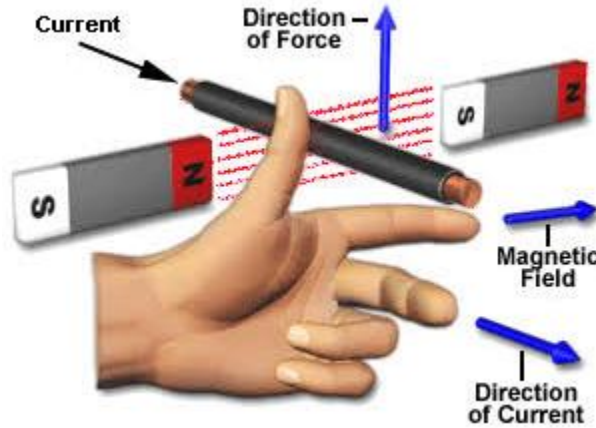
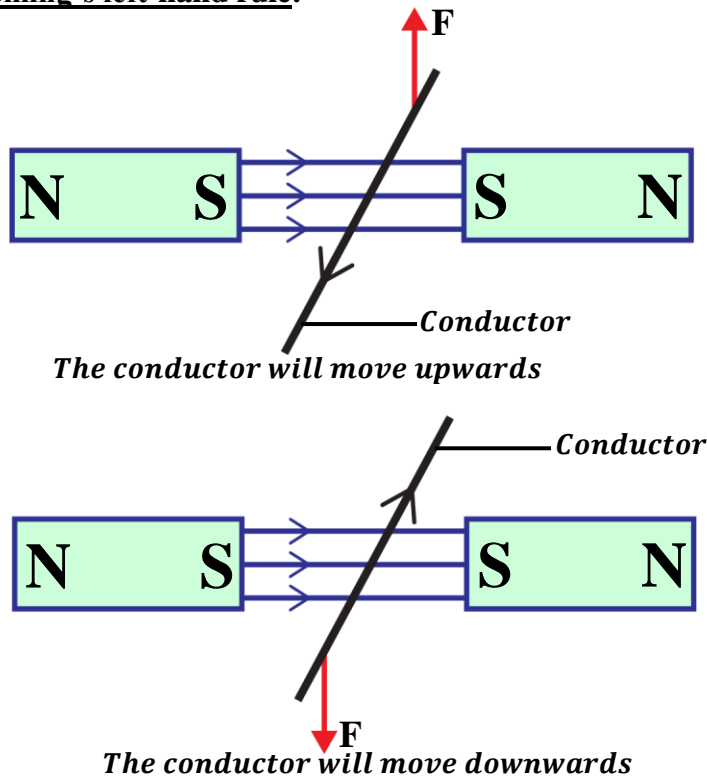
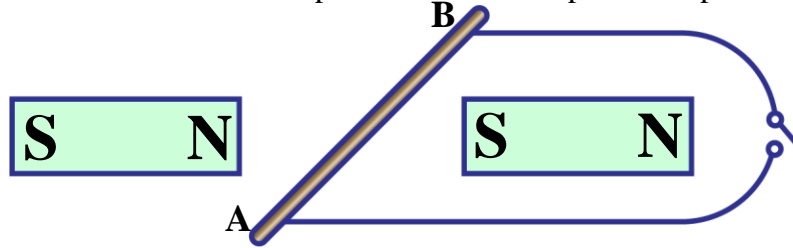

Illustration of Fleming's left-hand rule:



Example:

The diagram below shows a wire AB placed between the poles of a permanent magnet.



State what is observed when current flows in the wire using Fleming's left hand rule.

(i) In the direction AB.

The wire moves upwards

(ii) In the direction BA.

The wire moves downwards

Factors that affect magnitude of force on a current carrying conductor:

a) **Amount of current:**

Increasing the amount of current flowing in the conductor increases the magnitude of force created.

b) **Strength of magnetic field:**

Increasing the strength of magnetic field increases the magnitude of force created. This can be done by using a stronger magnet.

c) **Length of a conductor:**

Increasing the length of a conductor increases the magnitude of force created.

d) **Cross sectional area of a conductor:**

The larger the cross-sectional area of a conductor, the larger the force created.

NOTE:

When the magnetic field and current are parallel to each other, no force is exerted on the conductor.

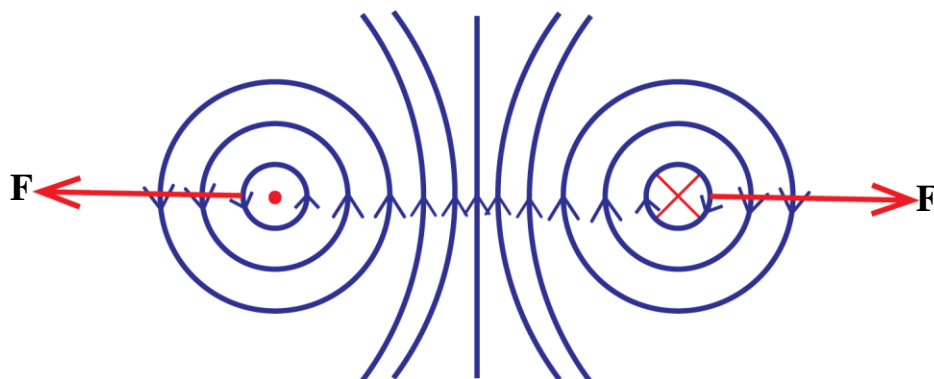
Force between two parallel conductors carrying current in opposite directions

The conductor repel each other



Force between two parallel conductors carrying current in the same direction

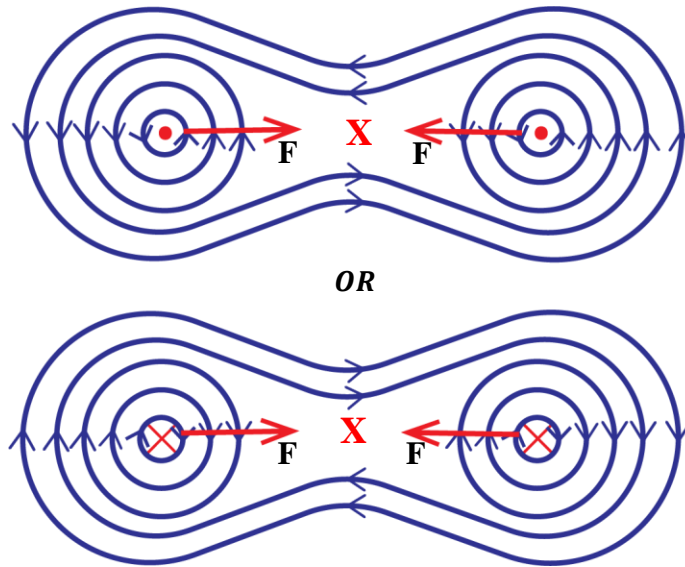

The conductor attract each other

APPLICATIONS OF MOTOR EFFECT

Force on a current carrying conductor can be applied in the following;

- Moving coil loud speaker
- D.C motor
- Moving coil galvanometer

MOVING COIL LOUD SPEAKER:

It consists of a light coil of wire known as a voice coil placed in a magnetic field provided by the permanent magnet.

Loud speakers can be used in; radios, Bluetooth speakers etc.

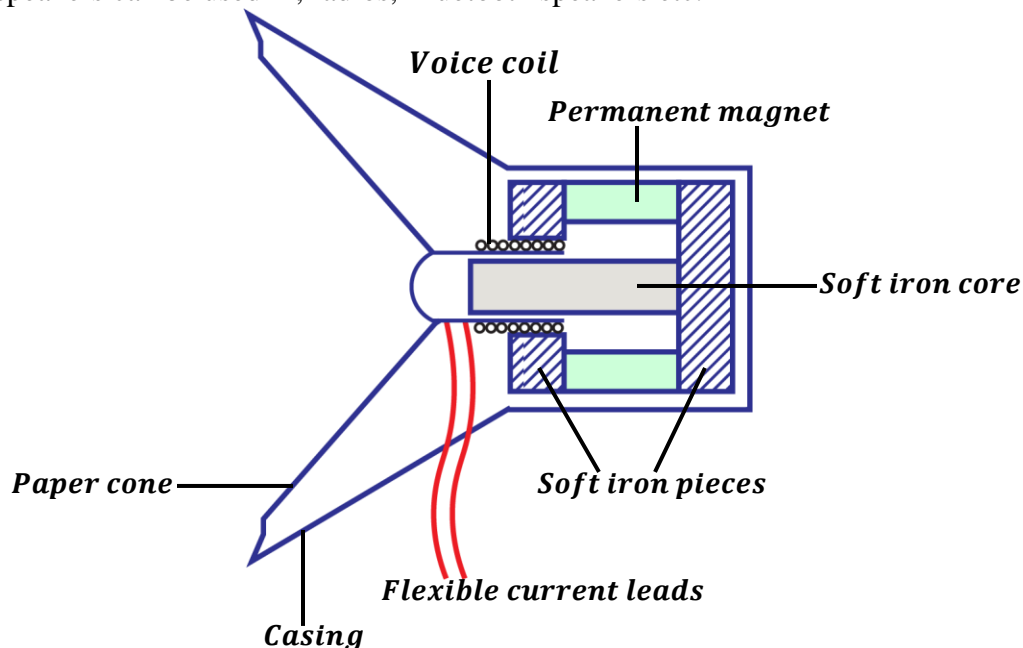

Mode of operation of a moving coil galvanometer:

- When varying current flows into the voice coil in a radial magnetic field of the permanent magnet, the voice coil experiences a varying force and vibrates at the same frequency as the current.
- This sets the paper cone to also vibrate at the same frequency as the current in voice coil.
- The vibration of the paper cone sets the air in contact with it to vibrate thus a loud sound is heard.

ELECTRIC MOTOR (D.C MOTOR)

The direct current motor converts electrical energy to kinetic energy.
They are used in; Printers, Fans, Water pumps etc.

Structure:

It consists of a rectangular coil which can rotate in a magnetic field provided by the permanent magnet. The ends of the coil are connected to two halves of a copper ring (split rings or commutators)

Two carbon brushes press against the commutators so that when the circuit is connected to a battery the coil rotates.

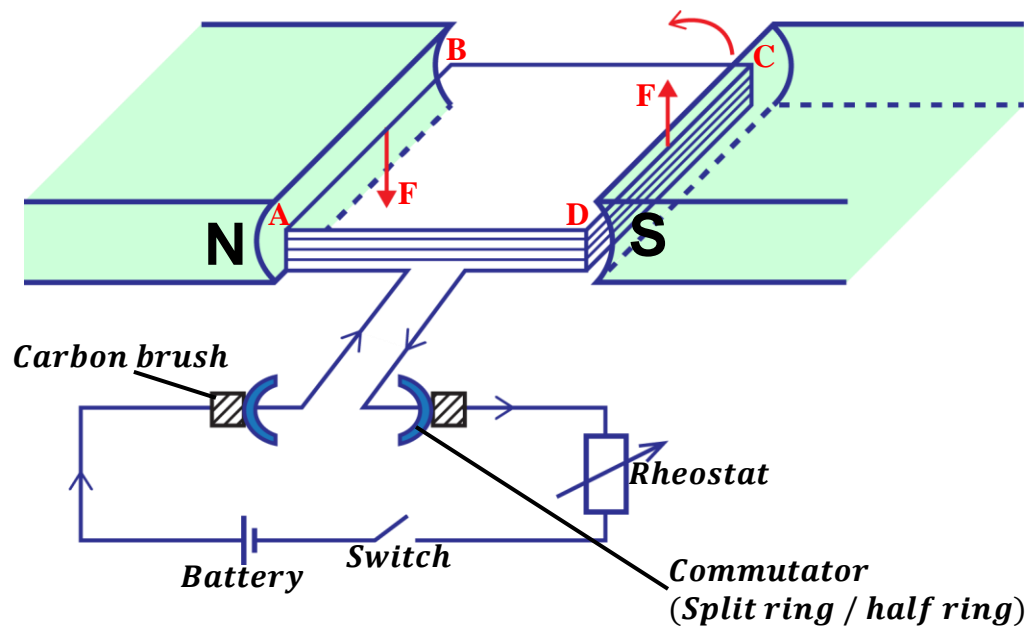
Mode of operation:

- When the switch is closed, current flows into the rectangular coil ABCD.
- Side CD experiences an upward force and side AB experiences a downward force according to Fleming's left hand rule.
- The two forces form a couple which causes the coil to rotate in the anticlockwise direction.
- When the coil rotates until it reaches the vertical position, the carbon brushes lose contact with the commutator and current is cut off.
- However, the coil continues to rotate and passes over the vertical position due to the momentum gained.
- The two commutators interchange contacts with the carbon brushes.



- This reverses the direction of current in the coil and the forces experienced by the sides of the coil.
- The coil continues to rotate as long as current is flowing.

Energy losses in an electric motor and how they are minimized.

ENERGY LOSS	HOW TO MINIMIZE IT
<ul style="list-style-type: none"> ▪ Energy loss due friction e.g. between carbon brushes and commutators. ▪ Energy loss due to heating effect in the coil due to resistance. ▪ Energy loss due to eddy currents. This is as a result of the changing magnetic flux in the coil. 	<ul style="list-style-type: none"> ▪ By lubricating i.e. oiling and greasing. ▪ By using thick copper wires of low resistance. ▪ By winding the coil on a laminated iron core.

Back emf of a motor;

When the coil cuts across the magnetic field of the permanent magnets, an emf is induced and acts in an opposite direction to the emf applied to rotate the motor.

The new emf induced is called **back emf**.

Let;

current through the armature = I_A

Initial emf applied to rotate the motor = E

Back emf induced = E_B

Resistance of the armature = R_A

Then;

$$\text{Current through the armature} = \frac{\text{Effective emf}}{\text{Resistance of the armature}}$$

$$I_A = \frac{E - E_B}{R_A}$$

$$\text{Efficiency of the motor} = \frac{\text{Power output}}{\text{Power input}}$$

$$\eta = \frac{I_A E_B}{I_A E} \times 100\%$$

$$\eta = \frac{E_B}{E} \times 100\%$$

The efficiency or strength of an electric motor can be increased by;

- Increasing current flowing through the coils.
- Increasing the number of turns in the coil.
- Using a stronger magnet to increase the strength of magnetic field.
- Winding the coil on a soft-magnetic material e.g. soft-iron.



Examples:

1. A motor whose armature resistance is 2Ω is operated on a 240V mains supply. Given the back emf in the motor is 220V.

Calculate;

- (i) the current through the armature.
 (ii) the efficiency of the motor.

$$\begin{aligned}
 & \text{(i)} \\
 R_A &= 2\Omega, \quad E = 240V, \quad E_B = 220V \\
 I_A &= \frac{E - E_B}{R_A} \\
 I_A &= \frac{240 - 220}{2} \\
 I_A &= \frac{20}{2} \\
 I_A &= 10A
 \end{aligned}$$

$$\begin{aligned}
 & \text{(ii)} \\
 \eta &= \frac{E_B}{E} \times 100\% \\
 \eta &= \frac{220}{240} \times 100\% \\
 \eta &= 91.7\%
 \end{aligned}$$

2. The current through the armature of an electric motor of resistance 6Ω is 2A. If the armature is connected to a 120V mains supply, calculate the efficiency of the motor.

$$\begin{aligned}
 R_A &= 6\Omega, \quad E = 120V, \\
 E_B &=?, \quad I_A = 2A, \quad \eta = ? \\
 I_A &= \frac{E - E_B}{R_A} \\
 2 &= \frac{120 - E_B}{6} \\
 E_B &= 120 - 12 \\
 E_B &= 108V
 \end{aligned}$$

$$\begin{aligned}
 \eta &= \frac{E_B}{E} \times 100\% \\
 \eta &= \frac{108}{120} \times 100\% \\
 \eta &= 90\%
 \end{aligned}$$

Exercise:

- A 240V vacuum cleaner motor takes a current of 0.6A. Find the efficiency of the motor if the useful mechanical power output is 72W. State how the rest of the energy is being wasted.
- An electric motor 90% efficient operates a water pump. If it raises 0.9kg of water through 20m every second, calculate;
 - Power output by the motor.
 - Back emf through the motor if the current through it is 5A.
 - Electric power supplied to the motor (power input).

MOVING COIL GALVANOMETER:

This is a device used to detect small currents and small potential differences (voltages)

Structure:

It consists of a rectangular coil wound on an aluminium former and placed over a cylindrical iron core. The coil rotates in the radial magnetic field provided by the poles of the permanent magnets. The radial magnetic field ensures that the coil is always perpendicular to magnetic flux. Current flows in and out of galvanometer through the hair springs. The hair springs also controls the rotation of the coil and the pointer.



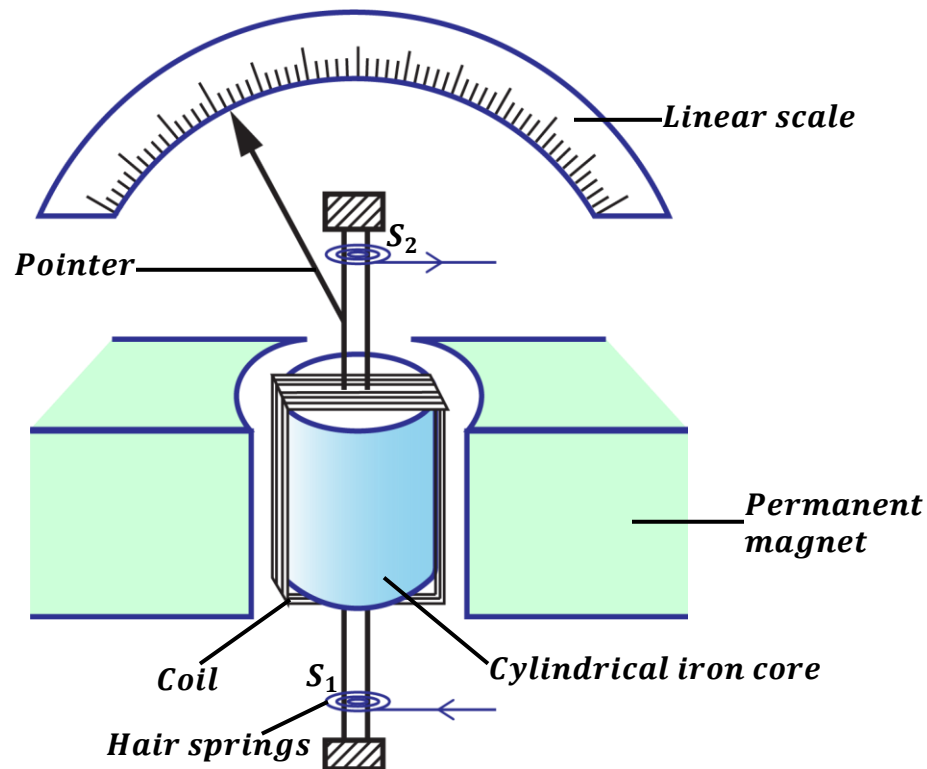

Mode of operation of a moving coil galvanometer:

- When current flows through the coil, the two vertical sides experience parallel opposite forces.
- The two forces form a couple which causes to rotate until it is stopped by the hair springs.
- As the coil rotates, the pointer deflects on the linear scale showing the amount of current flowing in the coil.
- When current stops flowing, the hair springs return the pointer to zero position on the scale.

SENSITIVITY OF A GALVANOMETER:

A galvanometer is said to be more sensitive if it can detect very small currents and very small voltages.

There are two types of sensitivity namely;

Current sensitivity: This is the deflection per unit current.

Voltage sensitivity: this is the deflection per unit voltage.

How to increase the sensitivity of a galvanometer.

- By using a strong magnet to provide a strong magnetic field.
- By increasing the number of turns on the coil.
- By using a coil of large cross sectional area.
- By using very weak hair springs.

Advantages of a moving coil galvanometer:

- It is used to measure both alternating and direct current.
- It has a linear scale.
- It is not affected by external magnetic fields.
- It is portable.



CONVERTING A GALVANOMETER INTO A VOLTMETER

Recall: A voltmeter has a high resistance so that no current can pass through it.

A galvanometer reads very small voltages in milli-voltages and can be converted into a voltmeter to read large voltages.

This can be done by connecting a **multiplier** in series with the galvanometer.

Definition:

A **multiplier** is a resistor of high resistance.

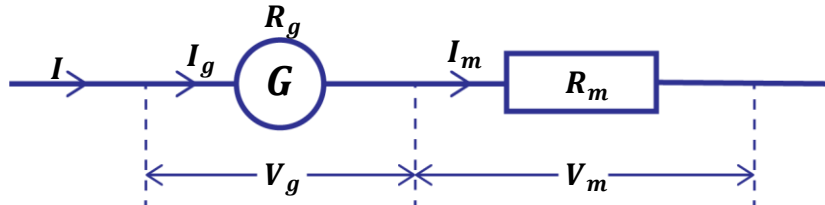

Total P.d = P.d across galvanometer + P.d across multiplier

$$V = V_g + V_m$$

But from Ohm's law $V_g = I_g R_g$, $V_m = I_m R_m$

$$V = I_g R_g + I_m R_m$$

Since the galvanometer and multiplier are in series, the current through galvanometer is equal to current through multiplier i.e. $I_g = I_m$

$$V = I_g R_g + I_g R_m$$

Examples:

1. A moving coil galvanometer of resistance 6Ω gives a full scale deflection of 15mA . How can it be converted to a voltmeter which can measure a maximum voltage of 5V ?

$$I_g = 15\text{mA} = \frac{15}{1000} = 0.015\text{A} \quad V = 5\text{V}$$

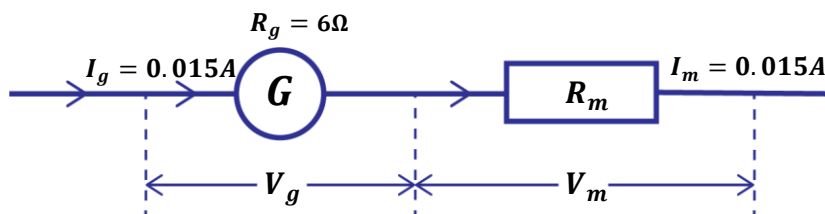

$$V = V_g + V_m$$

$$V = I_g R_g + I_m R_m$$

$$5 = 0.015 \times 6 + 0.015 \times R_m$$

$$5 = 0.09 + 0.015 R_m$$

$$\frac{5 - 0.09}{0.015} = R_m$$

$$R_m = 327.33\Omega$$

A multiplier of 327.33Ω should be connected in series with the galvanometer.



2. A moving coil galvanometer reads 0.05A at full scale deflection and has a resistance of 2Ω . Calculate the resistance that should be connected in series with the galvanometer so as to convert it to a voltmeter which reads 15V at full scale deflection.

$$I_g = 0.05A \quad V = 15V$$

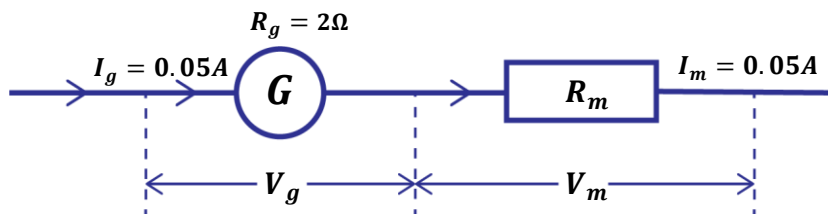

$$V = V_g + V_m$$

$$V = I_g R_g + I_m R_m$$

$$15 = 0.05 \times 2 + 0.05 \times R_m$$

$$15 = 0.1 + 0.05R_m$$

$$\frac{15 - 0.1}{0.05} = R_m$$

$$R_m = 298\Omega$$

A multiplier of 298Ω should be connected in series with the galvanometer.

CONVERTING A GALVANOMETER INTO AN AMMETER

Recall: An ammeter has a very low resistance so that a large current can pass through it. A galvanometer reads very small currents in milli-amperes and can be converted into an ammeter to read large currents.

This can be done by connecting a **shunt** in parallel with the galvanometer.

Definition:

A **shunt** is a resistor of low resistance.

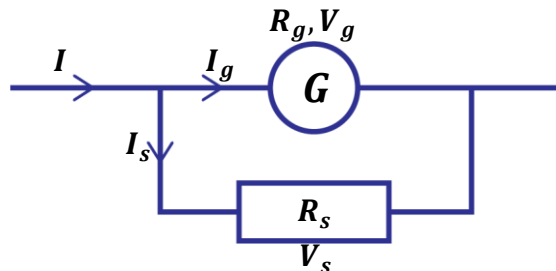

Total current = current through galvanometer + current through shunt.

$$I = I_g + I_s$$

$$I_s = I - I_g$$

Since the galvanometer and shunt are in parallel, the P.d across the galvanometer is equal to P.d across the shunt.

$$V_g = V_s$$

But from Ohm's law $V_g = I_g R_g$, $V_s = I_s R_s$

$$I_g R_g = I_s R_s$$

$$R_s = \frac{I_g R_g}{I_s}$$



Examples:

1. A galvanometer of resistance 20Ω gives a full scale deflection of 5mA . How can it be converted to an ammeter which can measure a maximum current of 2A ?

$$I_g = 5\text{mA} = \frac{5}{1000} = 0.005\text{A}$$

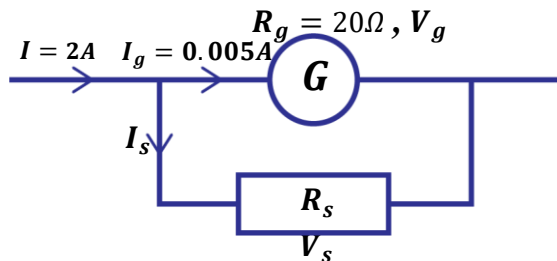

$$\begin{aligned} I &= I_g + I_s \\ I_s &= I - I_g \\ I_s &= 2 - 0.005 \\ I_s &= 1.995\text{A} \end{aligned}$$

$$\begin{aligned} V_g &= V_s \\ I_g R_g &= I_s R_s \\ 0.005 \times 20 &= 1.995 \times R_s \\ 0.1 &= 1.995 R_s \\ R_s &= \frac{0.1}{1.995} \\ R_s &= 0.05\Omega \end{aligned}$$

A shunt of resistance 0.05Ω should be connected in parallel with the galvanometer.

2. A moving coil galvanometer of resistance 4Ω gives a full scale deflection of 25mA . Calculate the value of the resistance required to convert it to an ammeter which reads 15A at f.s.d.

$$I_g = 25\text{mA} = \frac{25}{1000} = 0.025\text{A}$$

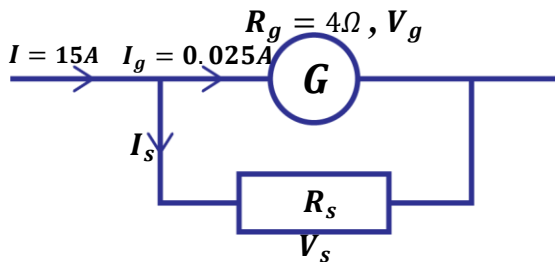

$$\begin{aligned} I &= I_g + I_s \\ I_s &= I - I_g \\ I_s &= 15 - 0.025 \\ I_s &= 14.975\text{A} \end{aligned}$$

$$\begin{aligned} V_g &= V_s \\ I_g R_g &= I_s R_s \\ 0.025 \times 4 &= 14.975 \times R_s \\ 0.1 &= 14.975 R_s \\ R_s &= \frac{0.1}{14.975} \\ R_s &= 0.006678\Omega \end{aligned}$$

A shunt of resistance 0.006678Ω should be connected in parallel with the galvanometer.

3. A moving coil galvanometer of internal resistance 4Ω gives a maximum deflection when a current of 2mA flows through it. A shunt of resistance 0.06Ω is used to convert the galvanometer into an ammeter.
- Find the current through the shunt.
 - The maximum current that can be measured by the set up.



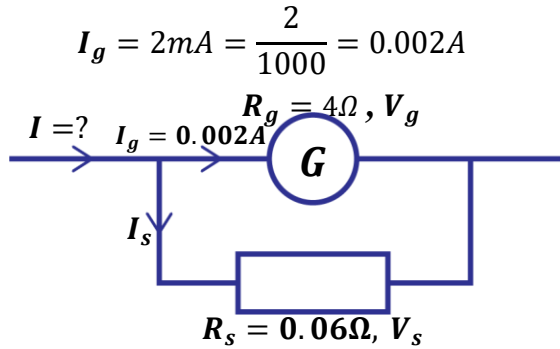

(i)

$$V_g = V_s$$

$$I_g R_g = I_s R_s$$

$$0.002 \times 4 = I_s \times 0.06$$

$$0.008 = 0.06 I_s$$

$$I_s = \frac{0.008}{0.06}$$

$$I_s = 0.133A$$

(ii)

$$I = I_g + I_s$$

$$I = 0.002 + 0.133$$

$$I = 0.135A$$

4. A moving coil galvanometer of resistance 5Ω and current sensitivity of 2 divisions per milliampere gives a full-scale deflection of 16 divisions.
- (i) Calculate current through the galvanometer.
- (ii) Calculate the voltage across the galvanometer if 1 division represents 2V.

(i)

Current sensitivity = 2div/mA
 Full scale deflection = 16divisions

$$\begin{array}{l} 2div \rightarrow 1mA \\ 16div \rightarrow I_g \end{array}$$

$$I_g = \frac{16}{2} = 8mA$$

(ii)

Voltage sensitivity = 1div/2V
 Full scale deflection = 16divisions

$$\begin{array}{l} 1div \rightarrow 2V \\ 16div \rightarrow V_g \end{array}$$

$$V_g = 16 \times 2 = 32V$$

EXERCISE:

- A moving coil galvanometer of resistance 4Ω gives a full scale deflection of 1.5mV. How can it be converted to voltmeter which can measure a maximum voltage of 2V?
Ans: [5329.3Ω]
- A moving coil galvanometer of resistance 10Ω gives a full scale deflection of 25mA. How can it be converted to an ammeter which can measure a maximum current of 2.5A?
Ans: [0.101Ω]
- A moving coil galvanometer of resistance 50Ω gives a full scale deflection of 5mV. How can it be converted to an ammeter which can measure a maximum current of 2A?
Ans: [0.0025Ω]
- Consider a full scale deflection when a current of 15mA flow through it. If the resistance of the galvanometer is 5Ω , find the magnitude of the resistance (multiplier) to be used for it to measure a maximum p. d of 15V
Ans: [995Ω]
- A moving coil galvanometer has resistance of 0.5Ω and full scale deflection of 2mA. How can it be modified to read current to voltage 10V
Ans: [4999 Ω]
- A moving coil galvanometer has resistance of 0.5Ω and full scale deflection of 2mA. How can it be adopted to read current 6A?
Ans: [1.67 × 10⁻⁴Ω]



7. Consider a moving coil galvanometer which has resistance of 5Ω and full scale deflection when a current of 15mA . A suppose a maximum current of 3A is to be measured using this galvanometer. What is the value of the shunt required.
Ans: [0.025 Ω]
8. A galvanometer of internal resistance of 20Ω and full scale deflection of 5mA . How can it be modified for use as;
(i) 1.0A ammeter
(ii) 100V voltmeter
Ans: (i). [1.05 Ω] (ii). [1980 Ω]
9. A milliammeter has a full scale reading of 0.01A and has resistance 20Ω . Show how a suitable resistor may be connected in order to use this instrument as a voltmeter reading up to 10V .
Ans: [980 Ω]

ELECTROMAGNETIC INDUCTION

When a conductor (e.g. wire) moves across a magnetic field such that it cuts the magnetic field lines (magnetic flux), an emf/current is induced in the conductor. Therefore, an emf is induced whenever magnetic flux changes and the induced emf causes current to flow.

Definition:

Electromagnetic induction is the process by which an emf is induced in the coil due to change in magnetic flux linking the coil.

Factors that determine the magnitude of induced emf/current:

- (i) **Number of turns;**
The magnitude of induced emf is increased by increasing the number of turns of the coil.
- (ii) **Strength of the magnet;**
The magnitude of induced emf can be increased by using a strong magnet to provide a stronger magnetic field.
- (iii) **Area of coil in magnetic field;**
The magnitude of induced emf is increased by placing a large area of coil into the magnetic field.
- (iv) **Rate at which magnetic flux changes;**
Increasing the speed of motion of a magnet in the coil increases the size of emf induced.



Direction of induced emf/current:

The direction of induced current can be found by Fleming's right hand rule.

It states that if the thumb, first and second fingers are placed at right angles to each other,

- thumb points in the direction of force (motion)
- the first finger points in the direction of magnetic field
- second finger points in the direction of induced current.

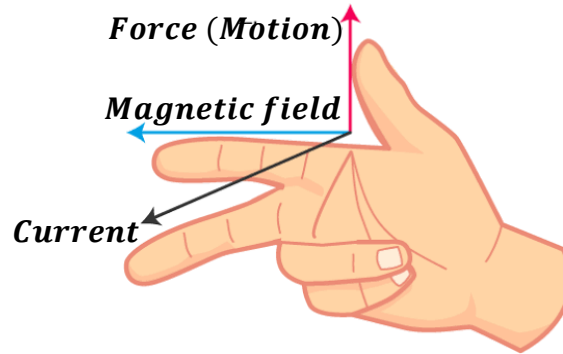

LAWS OF ELECTROMAGNETIC INDUCTION:

There are two laws of electromagnetic induction namely;

- Faraday's law
- Lenz's law

Faraday's law:

It states that the magnitude of induced emf in a coil is directly proportional to the rate of change of magnetic flux linking the coil.

Lenz's law:

It states that the induced current flows in a direction so as to oppose the change causing it.

Experiment to verify Lenz's law of electromagnetic induction:

Ends of a solenoid are connected to a galvanometer.

A magnet with its south pole facing towards the solenoid is moved into the coil and then pulled out.

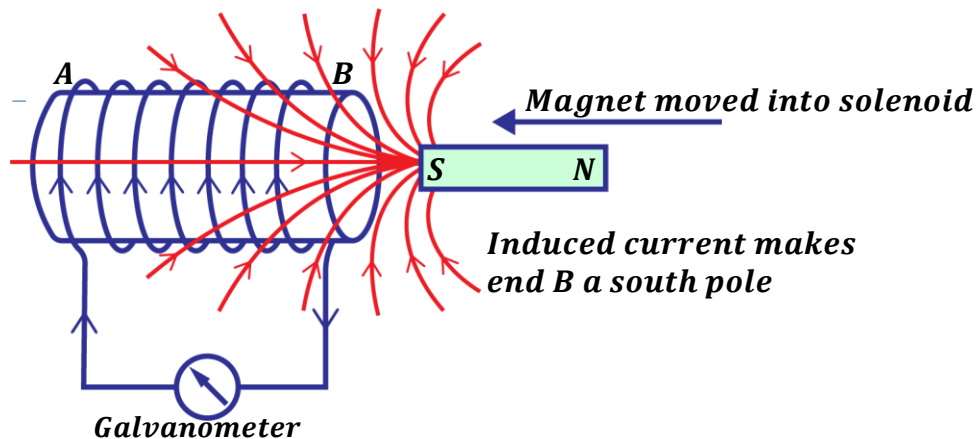

When a magnet is moved/plunged into the solenoid;

- **The galvanometer deflects to the left.** This is because current is induced in the solenoid and it flows in a clockwise direction to produce a South pole to oppose the approaching magnet. (**Fleming's right hand rule**)
- **The magnet is repelled by the solenoid.** This is because the induced current is flowing in the direction that makes end B of the solenoid to be a south pole.

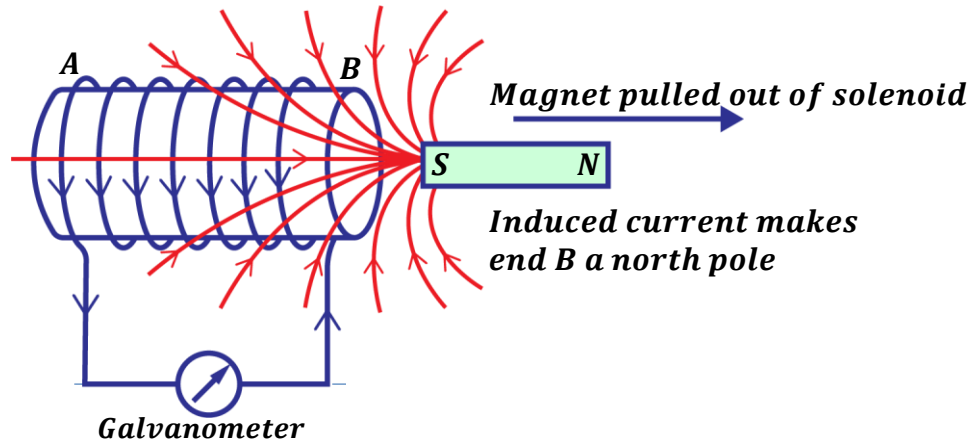

When a magnet is pulled out of the solenoid;

- **The galvanometer deflects to the right.** This is because current is induced in the solenoid and it flows in an anticlockwise direction to produce a North pole to oppose the leaving magnet. (**Fleming's right hand rule**)
- **The magnet is attracted by the solenoid.** This is because the induced current is flowing in the direction that makes end B of the solenoid to be a north pole.

Note: The speed of deflection of pointer on the galvanometer increases when the magnet is moved in and out at a faster rate.

Example:

1. The figure below shows a conductor connected to a galvanometer and placed in a magnetic field of two magnets.

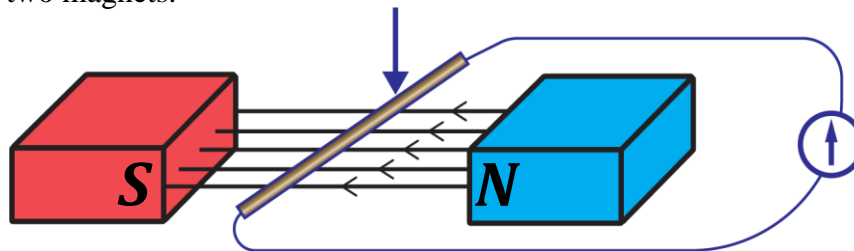

State what happens

- (a) When the conductor is moved down.
The galvanometer deflects to the left showing that current is induced in the conductor and it flows in clockwise direction.
- (b) When the conductor is moved up.
The galvanometer deflects to the right showing that current is induced in the conductor and it flows in anticlockwise direction.



- (c) when conductor is slowly moved up and then moved down faster
The galvanometer deflects to the right slowly and then to the left at a faster rate.
2. The figure below shows a magnet moved towards a cylindrical coil connected to a galvanometer.

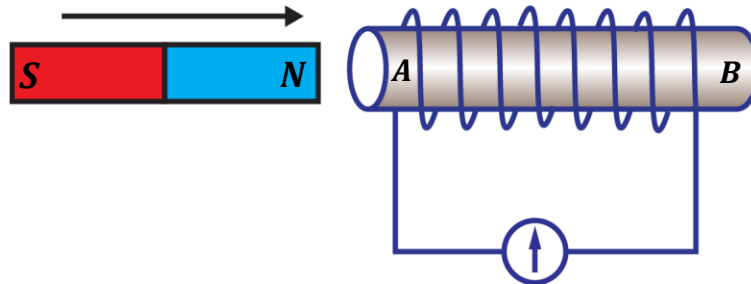

- (a) Explain what will be observed in the figure above.
The galvanometer deflects to the left because current is induced and it flows in a clockwise direction so that the end A is made a North pole to oppose the approaching magnet thus the magnet is repelled.
- (b) State how the magnitude of current induced in the figure above can be increased.
- *By increasing the number of turns of the coil.*
 - *By using a stronger magnet.*
 - *By increasing the speed at which the magnet is moving into the coil.*

APPLICATIONS OF ELECTROMAGNETIC INDUCTION

It is applied in;

- Generators
- Transformers

GENERATORS

A generator is a device that converts mechanical energy into electrical energy.

There are two types of generators namely;

- Direct current generator (dynamo)
- Alternating current generator (alternator)

D.C generator (Dynamo)

Structure:

It consists of the following;

- ❖ Permanent magnets which provide strong magnetic fields.
- ❖ An armature/ rectangular coil which rotates in the magnetic field.
- ❖ Carbon brushes which get current from split rings (commutators)



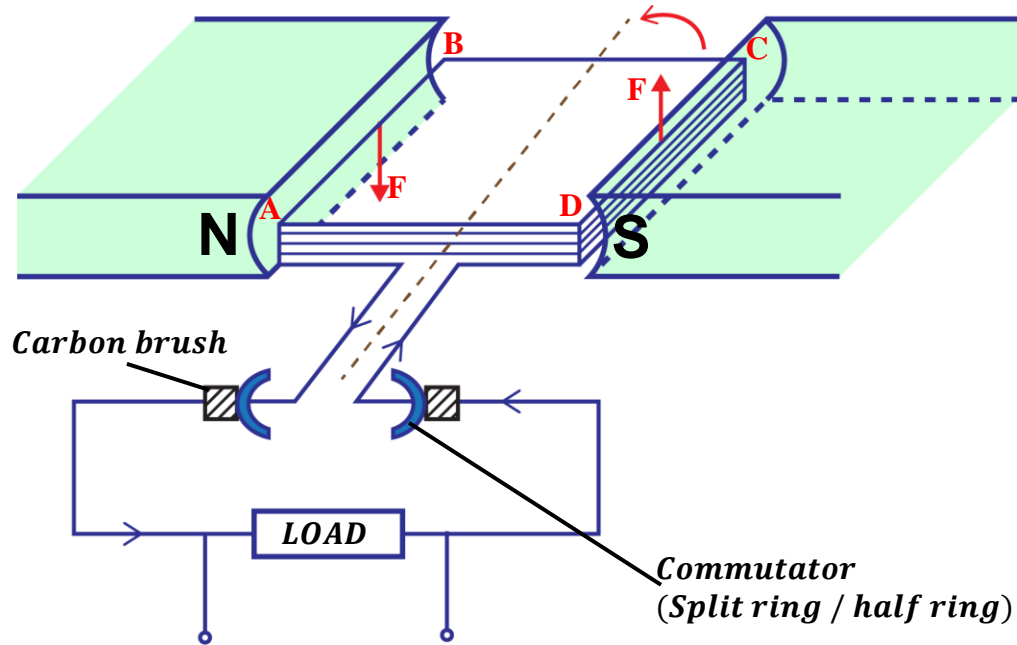

Mode of operation of a d.c generator

- When the rectangular coil ABCD rotates, the magnetic flux linking the coil changes and an emf is induced in the coil causing current to flow in the coil.
- When the coil passes over the vertical position, the split rings change contacts from one carbon brush to another. This reverses the direction of current in the coil.
- Therefore, the direction of current flowing through the load remains the same.

A graph of induced emf against time for a d.c generator.

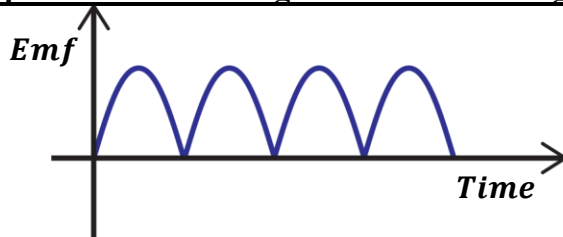

Note:

- The induced emf or current is maximum when the plane of the coil is horizontal. This is because cutting of the magnetic field lines is greatest at this point by the moving coil (*i. e.* 90°)
- The induced emf or current is minimum when the plane of the coil is vertical. This is because cutting of the magnetic field lines is minimum at this point by the moving coil (*i. e.* 0°)

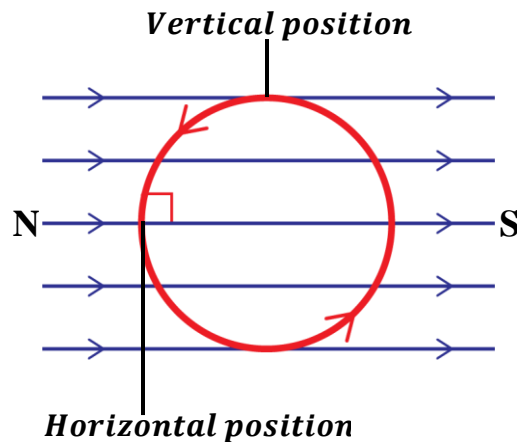

A.C generator (Alternator):

In A.C generators slip rings are used instead of split rings.

Note: A slip ring is a device that connects a stationary object (carbon brush) to a rotating object (rectangular coil)

Therefore, slip rings are always fixed.

Structure:

It consists of the following;

- ❖ Permanent magnets which provide strong magnetic fields.
- ❖ An armature / rectangular coil which rotates in the magnetic field.
- ❖ Carbon brushes which get current from the slip rings

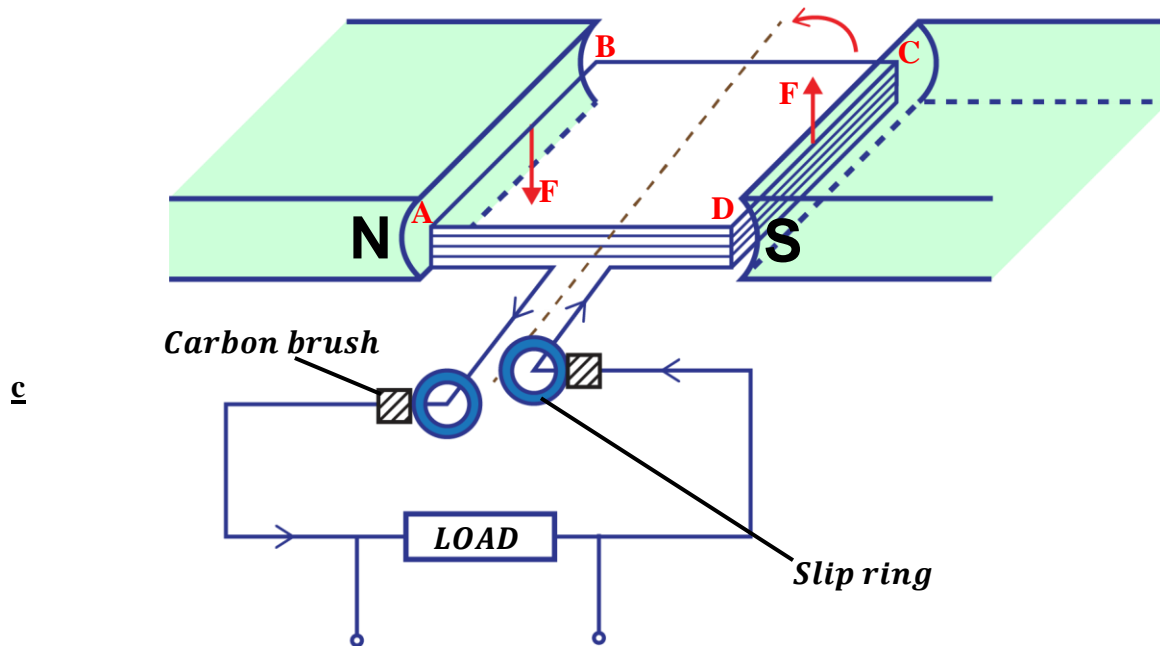

Mode of operation of an A.C generator

- When the rectangular coil ABCD rotates, the magnetic flux linking the coil changes and an emf is induced in the coil causing current to flow in the coil.
- When the coil passes over the vertical position, the slip rings change contacts from one carbon brush to another. This reverses the direction of current in the coil.
- Therefore, the direction of current flowing through the load also changes.

A graph of induced emf against time for an A.C generator.

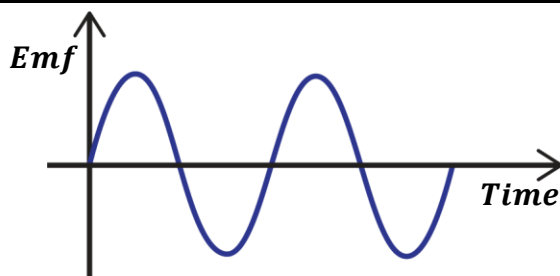

TYPES OF INDUCTION

There are two types namely;

- Self -induction
- Mutual induction

Self- induction:

This is the process by which an emf is induced in the coil due to changing current in the same coil.

The magnetic flux due to the current in the coil links that coil and if the current changes, the resulting flux change induces an emf in the coil itself.

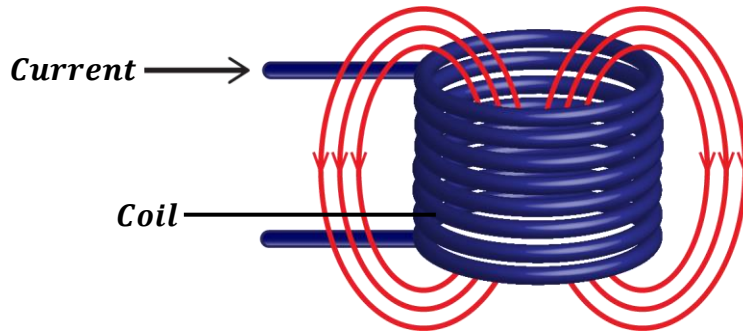

Mutual induction:

This is the process by which an emf is induced in the coil due to changing current in the nearby coil.

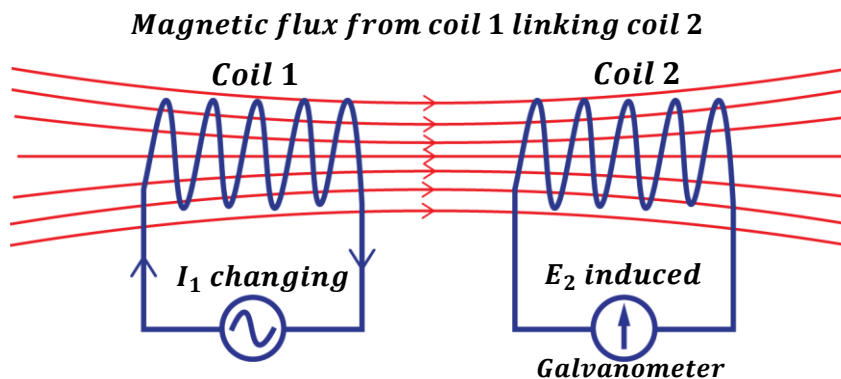

In mutual induction, emf is induced in coil 2 (secondary coil) due to change in current in coil 1 (primary coil).

This is applied in transformers



TRANSFORMERS

This is an electric device that is used to step up or step down voltage.

OR

This is an electric device that is used to increase or decrease alternating voltage.

Transformers are normally used in electrical appliances e.g. radio receivers, TV sets, battery chargers etc. where the input voltage has to be changed.

Structure of a transformer:

It consists of a laminated soft iron ring around which primary and secondary coils are wound. The soft iron ring concentrates the magnetic fields produced.

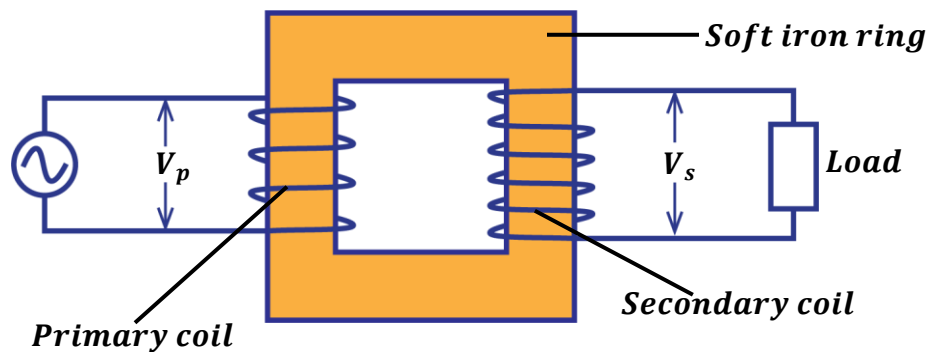

Mode of operation of a transformer:

- When alternating voltage V_p is applied to the primary coil, alternating current flows through the primary coil.
- The alternating current creates a changing magnetic flux in the primary coil which links up with the secondary coil.
- An emf V_s is induced in the secondary coil due to the changing magnetic flux.
- The induced emf depends on the number of turns in the secondary coil.

TYPES OF TRANSFORMERS:

There are two types namely;

(i) Step up transformer;

This is the type of transformer whose number of turns in the secondary coil is greater than the number of turns in the primary coil.

They are usually put at power and transmission stations.

(ii) Step down transformer;

This is the type of transformer whose number of turns in the secondary coil is less than the number of turns in the primary coil.

They are usually put near consumer places and in electrical appliances.



ENERGY/POWER LOSSES IN A TRANSFORMER

ENERGY LOSS	HOW IT IS MINIMIZED
(i) <u>Energy loss due to heating effect</u> (I^2R); <i>This is because of the resistance of the coils.</i>	By using low resistance thick copper wires.
(ii) <u>Energy loss due to eddy currents;</u> <i>Eddy currents are currents induced in the core due changing magnetic flux and they cause unnecessary heat.</i>	By using a laminated soft iron core.
(iii) <u>Energy loss due to hysteresis;</u> <i>This happens when magnetization of the core is reversed. So, if it is not easily magnetized and demagnetized, some power is wasted in overcoming internal friction.</i>	By using a soft iron core which can be easily magnetized and demagnetized.
(iv) <u>Energy loss due to flux leakage;</u> <i>This occurs when some magnetic flux fails to link up to the secondary coil.</i>	By using an E-shaped iron core so that all the flux in the primary coil links up to the secondary coil.

Uses of eddy currents:

- They are used in electromagnetic brakes.
- They are used to detect cracks in metals.

Transformer equations:

$$\frac{\text{Voltage in primary coil, } V_p}{\text{Voltage in secondary coil, } V_s} = \frac{\text{Number of turns in primary coil, } N_p}{\text{Number of turns in secondary coil, } N_s}$$

$$\boxed{\frac{V_p}{V_s} = \frac{N_p}{N_s}}$$

$$\text{Efficiency} = \frac{\text{Power output}}{\text{Power input}} \times 100\%$$

where Power output = power in secondary circuit = $I_s V_s$

Power input = power in primary circuit = $I_p V_p$

$$\boxed{\text{Efficiency} = \frac{I_s V_s}{I_p V_p} \times 100\%}$$

Definition:

An **ideal transformer** is a transformer where there are no energy losses.

Therefore, an ideal transformer is 100% efficient i.e. *power output = power input*

In real life situations, there is no transformer which is 100% efficient.



Examples:

1. A transformer is used to step down an alternating voltage from 240V to 12V. Calculate the number of turns on the secondary coil if the primary coil has 2000 turns.

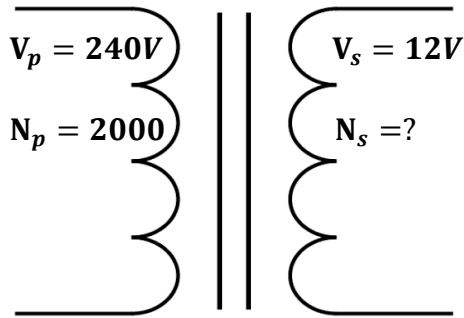

$$\frac{V_p}{V_s} = \frac{N_p}{N_s}$$

$$\frac{240}{12} = \frac{2000}{N_s}$$

$$N_s = \frac{2000 \times 12}{240}$$

$$N_s = 100 \text{ turns.}$$

2. A transformer whose efficiency is 80% has an output power of 12W. Calculate the input current if the input voltage is 240V.

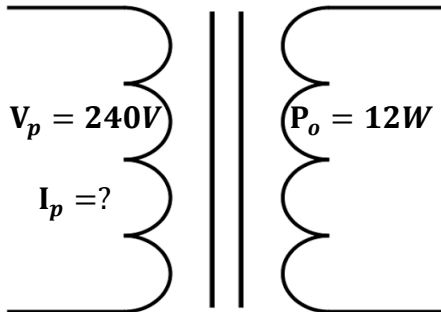

$$\text{Efficiency} = 80\%$$

$$\text{Efficiency} = \frac{\text{Power output}}{\text{Power input}} \times 100\%$$

$$80\% = \frac{12}{P_i} \times 100\%$$

$$P_i = \frac{12 \times 100}{80}$$

$$P_i = 15W$$

$$\text{Power input, } P_i = I_p V_p$$

$$15 = I_p \times 240$$

$$I_p = \frac{15}{240}$$

$$I_p = 0.0625A$$

3. A transformer is converted to 240V a.c mains. If the primary coil has 1200 turns and a resistor of 3Ω is connected to secondary coil of 60 turns.

Calculate;

- (i) p.d across the secondary coil.
(ii) current through the 3Ω resistor.

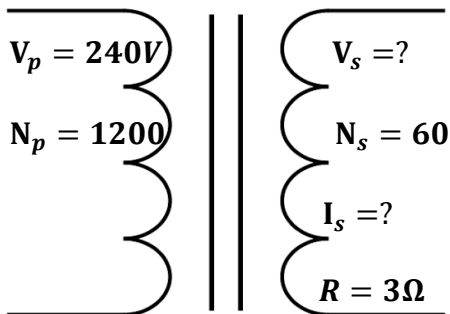

(i)

$$\frac{V_p}{V_s} = \frac{N_p}{N_s}$$

$$\frac{240}{V_s} = \frac{1200}{60}$$

$$V_s = \frac{240 \times 60}{1200}$$

$$V_s = 12V$$

(ii)

From ohm's law;

$$V_s = I_s R$$

$$12 = I_s \times 3$$

$$I_s = \frac{12}{3}$$

$$I_s = 4A$$



4. A transformer is designed to work on a 240V, 60W supply. It has 3000 turns in the primary and 200 turns in the secondary and it is 80% efficient. Calculate the current in primary and secondary coils.

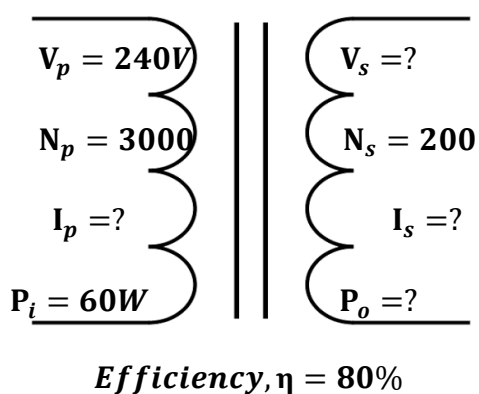

Current in primary coil

$$\text{power input} = I_p V_p$$

$$60 = I_p \times 240$$

$$I_p = \frac{60}{240}$$

$$I_p = 0.25A$$

$$\frac{V_p}{V_s} = \frac{N_p}{N_s}$$

$$\frac{240}{V_s} = \frac{3000}{200}$$

$$V_s = \frac{240 \times 200}{3000}$$

$$V_s = 16V$$

Current in second coil

$$\eta = \frac{P_o}{P_i} \times 100\%$$

$$\text{but } P_o = I_s V_s$$

$$80\% = \frac{I_s V_s}{P_i} \times 100\%$$

$$80 = \frac{I_s \times 16}{60} \times 100$$

$$I_s = \frac{80 \times 60}{16 \times 100}$$

$$I_s = 3A$$

5. A setup transformer is designed to operate from a 240V supply with delivery energy at 250V. If the transformer is 90% efficient, determine the current into the primary winding when the output terminals are connected to 250V, 100W lamp.

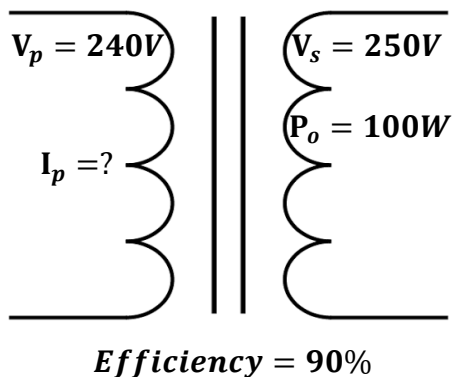

$$\text{Efficiency} = \frac{\text{Power output}}{\text{Power input}} \times 100\%$$

$$90\% = \frac{100}{P_i} \times 100\%$$

$$P_i = \frac{100 \times 100}{90}$$

$$P_i = 111.11W$$

$$\text{Power input, } P_i = I_p V_p$$

$$111.11 = I_p \times 240$$

$$I_p = \frac{111.11}{240}$$

$$I_p = 0.4629A$$

6. An electric power generator produces 24kW at 240V, the voltage is stepped up to 400V for transmission to a factory. The total resistance of the transmission wire is 0.5Ω.
- What is the ratio of number of turns in primary to number of turns in secondary is the transformer.
 - Find the power loss in transmission lines assuming both transformers are 100% efficient.



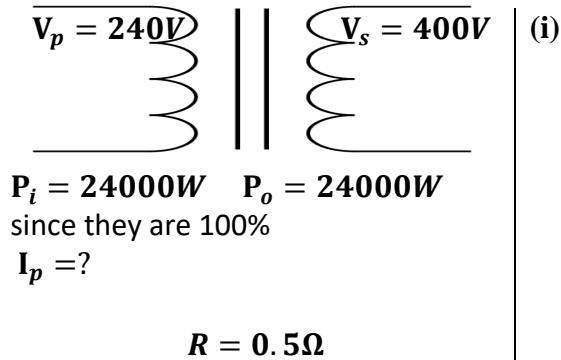

$$\frac{V_p}{V_s} = \frac{N_p}{N_s}$$

$$\frac{N_p}{N_s} = \frac{240}{400}$$

$$\frac{N_p}{N_s} = \frac{3}{5}$$

$$N_p : N_s = 3 : 5$$

(ii)

power output $P_o = I_s V_s$

$$24000 = I_s \times 400$$

$$I_s = \frac{24000}{400}$$

$$I_s = 60A$$

Power loss in wires

$$P = I_s^2 R$$

$$P = 60^2 \times 0.5$$

$$P = 1800W$$

7. A transformer is designed to operate at 240V main supply and deliver 9V. The current drawn from the main supply is 1A if the efficiency of the transformer is 90%. Calculate

- (i) maximum power output
(ii) power lost

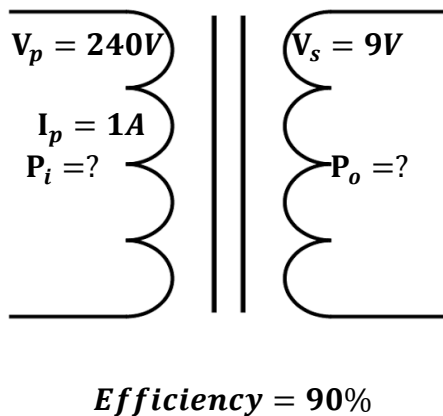

(i)

Power input, $P_i = I_p V_p$

$$P_i = 1 \times 240$$

$$P_i = 240W$$

$$\text{Efficiency} = \frac{\text{Power output}}{\text{Power input}} \times 100\%$$

$$90\% = \frac{P_o}{240} \times 100\%$$

$$P_o = \frac{90 \times 240}{100}$$

$$P_o = 216W$$

(ii)

powerlost = $P_i - P_o$

$$\text{powerlost} = 240 - 216$$

$$\text{powerlost} = 24W$$

EXERCISE:

- A transformer has 800 turns in its primary coil and 3200 turns in its secondary coil. If it is connected to an alternate voltage of 240V. What is the output voltage?
Ans: [960V]
- If one wishes to step down voltage from 240V to 10V, determine the number of turns in the secondary if the primary coil has 4800 turns.
Ans: [200 turns]
- A step up transformer is 80% efficient if the number of turns of the coil is 2400 turns and 500 turns. Given that the input voltage and the output current are 240V and 0.25A. Calculate the output voltage and input current.
Ans: [1152V, 0.015A]



4. Find the ratio of number of turns of the primary to the number of turns in the secondary, if the voltage of 12V is stepped up to 18V.
Ans: [2: 3]
5. A 3V, 6W bulb is connected to the secondary coil of a transformer whose input voltage is 12V. Given that the transformer is 90% efficient and the bulb works at full capacity. Calculate the current in the secondary coil and the current in the primary coil
Ans: [2A, 1.8A]
6. An electric power is generated at 11kV. Transformers are used to raise the voltage to 440V for transmission over long distances using cables. The output of transformers is 19800W and they are 90% efficient. Find the input current to the transformer and the output current to the cables.
Ans: [45A, 2A]
7. A transformer is designed to produce an output of 240V when connected to a 25V supply. If the transformer is 80% efficient, calculate the input current when the output is connected to a 240V, 75W lamp.
Ans: [0.3125A, 0.0375A]
8. An *a. c* transformer operates on a 240V mains. The voltage across the secondary which has 960 turns is 20V.
(i) find the number of turns in the primary coil.
(ii) if the efficiency of the transformer is 80% calculate the in the primary coil when a resistor of 40Ω is connected across the secondary.
Ans: [11520turns, 0.0521A]
9. A transformer whose secondary col has 60 turns and primary 1200 turns has its secondary connected to a 3Ω resistor if its primary is connected to a 240V *a. c* supply. Calculate the current flowing in the primary assuming that the transformer is 80% efficient.
Ans: [0.25A]
10. A transformer is designed to work on a 240V, 60W supply, it has 3000 turns in the primary and 200 turns in the secondary and its efficiency is 80%. Calculate the current in the secondary coil.
Ans: [3A]
11. An *a.c* transformer operates on 240V mains. It has 1200 turns in the primary and gives 18V across the secondary.
(i) find the number of turns in the secondary
(ii) if the efficiency of the transformer is 90% calculate the current in the primary coil when a resistor of 50Ω is connected across the secondary
Ans: [90turns, 0.03A]



ALTERNATING AND DIRECT CURRENT

Direct Current (D.C) is the current which flows in one direction only.
All batteries produce direct current.

Alternating Current (A.C) is current which flows in opposite directions periodically.
This means that the direction of current flowing in a circuit is constantly being reversed back and forth.

The electric current supplied to our homes is alternating current. This comes from power plants that are operated by the electric company.
AC can be converted to DC by using rectifier

Advantages of A.C over D.C

A.C is easy to generate.

A.C is easy to transmit to around the country with minimal power loss.

Alternating current can easily be stepped up and down for home consumption.

Disadvantages of A.C over D.C

A.C cannot be used to charge a battery.

A.C cannot be used in electroplating.

A.C cannot be used in electrolysis.

EXAMINATION QUESTIONS

- Define the term neutral point as applied to magnetism.
 - Briefly explain how a rod of steel can be magnetized using the single touch stroking method.
 - Briefly explain how the soft iron core causes power loss in a transformer.
 - What is a magnetic field.
 - Draw a diagram of the magnetic field pattern when a bar magnet is placed in the earth's magnetic field with its south pole facing the geographical north.
 - List four features of magnetic flux.
- Define the following terms as applied to magnetism.
 - Ferromagnetic material.
 - Neutral point.
 - The figure below shows an electromagnet made by a pupil in the laboratory. The electromagnet is to pick up and release a metal object.

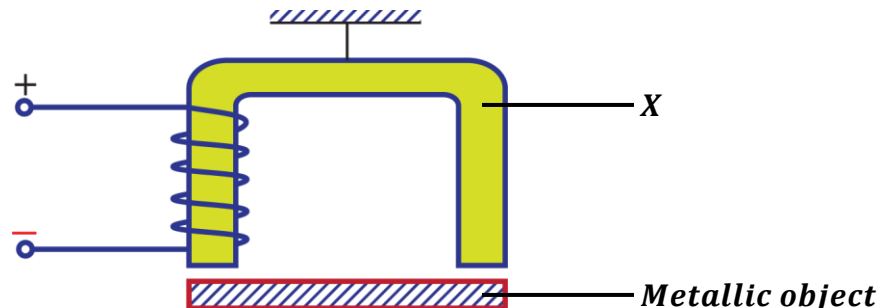

- i) Name a suitable material for X and explain why it is made from this material.
 - ii) Name two metals which a magnet will not attract.
 - iii) State two changes which a student could make so that a heavier metal object could be lifted by the electromagnet.
- c) A galvanometer of resistance 5Ω gives a full scale deflection for a current of 15mA . How may it be converted into?
- i) An ammeter reading up to 3A .
 - ii) A voltmeter reading up to 6V .

Ans: i) [$2.51 \times 10\Omega$] ii) [395Ω]

3. a) i) What is a magnetic field.
ii) State the law of magnetism.
- b) i) Explain with the aid of diagrams, how a steel bar can be magnetized by the single touch method.
ii) Sketch the magnetic field pattern around two bar magnets whose north poles face each other.
- c) With the aid of a labeled diagram, describe how a simple a.c generator works.
4. a) Describe briefly the structure and action of an a.c transformer.
- b) i) State any three causes of energy losses in a transformer.
ii) How are these losses reduced in a practical transformer?
- c) Explain why it is an advantage to transmit electrical power at high voltage.
- d) An electric power is generated at 11kV . Transformers are used to raise the voltage to 440kV for transmission over large distances using cables. The output of transformers is 19.8MW and they are 90% efficient. Find;
- i) The input current to the transformer.
 - ii) The output current to the cables.

Ans: i) [2kA] ii) [45A]

5. a) Explain how a piece of iron can be magnetized by the single touch method. Illustrate your answer with a diagram.
- b) How can you determine the polarity of a magnet?
- c) Explain why a magnet loses its magnetism when placed in a coil of a wire carrying an alternating current.
- d) Describe the motion of a beam of electrons directed midway between the north and south poles of a permanent magnet.
6. a) Describe with the aid of a labeled diagram, the structure and principle of operation of an a.c generator.
- b) An electric power generator produces 24kW at 240V a.c. The voltage is stepped up to 4000V for transmission to a factory, where it is then stepped down to 240V . The total resistance of the transmission wires is 0.5Ω .
- i) What is the ratio of the number of turns in the primary to the number of turns in the secondary of the step down transformer?
 - ii) Find the power lost in the transmission lines assuming both transformers are 100% efficient.

Ans: i) [$50:3$] ii) [18W]

- c) i) What power would have been lost if the same electric power had been transmitted directly to the factory through the same transmission wires without use of transformers.



ii) Comment on differences between the power losses in (b) (ii) and (c) (i) above.

Ans: i) [15kW]

7. a) i) Draw a labeled diagram to show essential parts of a d.c motor.
ii) Describe briefly how a d.c motor works.
- b) State three ways of increasing the torque of the motor.
- c) i) What factors make the efficiency of a motor less than 100%?
ii) How is each factor in (c) (i) above minimized?
- d) An electric motor of efficiency 90% operates a water pump. The pump raises 0.9kg of water through 10m every second.
i) What is meant by the term efficiency?
ii) State the energy changes which take place.
iii) Find the electrical power supplied to the motor.

Ans: iii) [100W]

8. a) i) What is a magnetic field?
ii) Draw a diagram of the magnetic field pattern between the north poles of two bar magnets placed near each other.
- b) Describe how you can plot the magnetic field around a wire carrying a current perpendicular to the plane of the paper.
- c) Draw a diagram to show what happens when two straight conductors placed vertically near each other carry a current in
i) The same direction.
ii) The opposite direction.
- d) Describe briefly two methods of magnetizing an iron rod.
- e) A transformer is designed to produce an output of 220V when connected to a 25V supply. If the transformer is 80% efficient, calculate the input current when the output is connected to a 220V, 75W lamp.

Ans: [3.75A]

9. a) State three factors on which the magnitude of the force exerted on a wire carrying a current in a magnetic field depends.
- b) With the aid of a labeled diagram, describe the action of a moving coil galvanometer
- c) A moving coil galvanometer has a coil of resistance 4Ω and gives a full scale deflection when a current of 25mA passes through it. Calculate the value of the resistance required to convert it to an ammeter which reads 15A at full scale deflection.

Ans: [6.68 × 10⁻³Ω]

10. a) With the aid of a diagram explain, the use of keepers to store magnets.
- b) i) Describe using a labeled diagram how a telephone receiver works.
ii) State two ways by which the strength of an electromagnet can be increased.
- c) i) A part from electrical method, mention two other methods of demagnetization.
ii) Explain how the above methods mentioned lead to magnetization.
- d) Describe how you would demagnetize a bar magnet by the electrical method.



11. a) What is a transformer
 b) The diagram below shows a model of a transformer in which the primary coil, P is connected to d.c and the secondary coil, S is connected to the galvanometer, G.

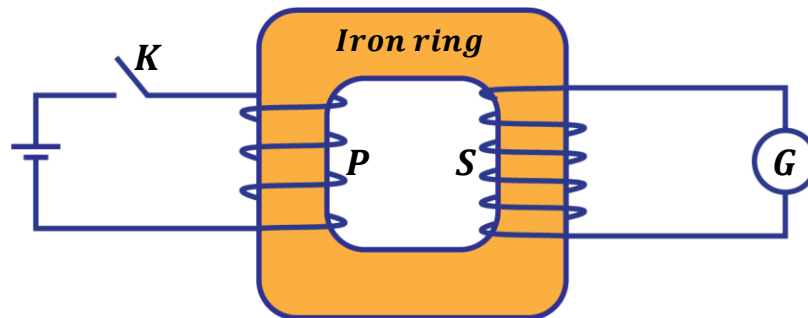

- What is observed just as the switch, K is closed.
 - What will be the effect of closing switch, K very fast in (i) above?
 - What is observed when the switch is left closed?
 - What is observed as the switch is opened.
 - What is observed if the d.c source is replaced by an a.c source of low frequency
- c) A transformer of efficiency 80% is connected to a 240V a.c supply to operate a heater of resistance 240Ω . If the current flowing in the primary circuit is 5A.
- Calculate the potential difference across the heater.
 - If the heater is cooled by oil of specific heat capacity $2,100Jkg^{-1}K^{-1}$ and the temperature of oil rises by 20° in 3 minutes, find the mass of oil used in cooling.

Ans: i) [48V] ii) [4.11kg]

12. a)
 - What is meant by a magnetic field.
 - Suggest any three characteristics of the magnetic field.
 b)
 - Describe in details how an iron bar can be magnetized by electrical method.
 - A galvanometer has resistance of 2Ω and gives a 50mA full scale deflection. Calculate the value of resistance that is used so that the meter reads current up to 2A.

Ans: ii) [5.13 × 10⁻²Ω]

- c) The diagram below is a transformer, study it and answer the questions that follow.

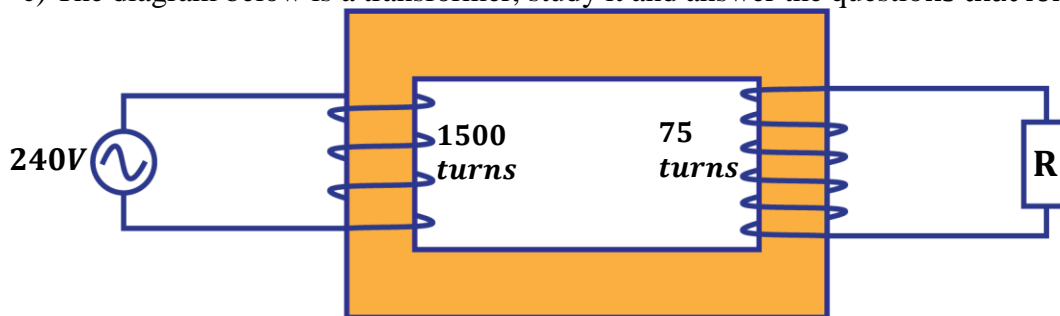

- Find the potential difference across R.
- If the current in the mains is 0.55A. What is the current in the secondary coil?
- With a reason name the type of the transformer.

Ans: i) [12V] ii) [11A]

13. a) State any two factors which determine the magnitude of a force exerted on a current carrying conductor.
 b) With the aid of a well labeled diagram, describe the structure and mode of action of a moving coil loud speaker.



- c) State the factors which determine the pitch and loudness of the sound produced by a moving coil loud speaker.
- d) A D.C motor has an armature resistance of 4Ω . If it draws a current of 10A when connected to a supply of 200V, calculate the
- Power wasted in the windings
 - Efficiency of the motor

Ans: i) [400W] ii) [80%]

14. a) The diagram below shows a coil connected to a centre-zero galvanometer, G.

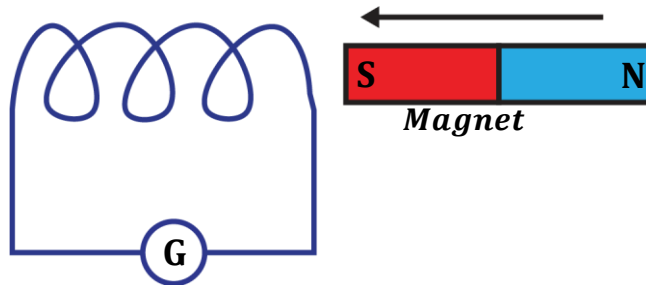

State and explain the deflection of the galvanometer needle when the magnet is

- Held stationary at one end of the coil
 - Moved slowly towards the coil
 - Left at rest inside the coil
 - Moved away from the coil
 - Moved quickly in and out of the coil about twice per second
- b) i) State four ways in which power is lost in a transformer
ii) How can the power loss be minimized in each case
- c) Distinguish between a d.c motor and a d.c generator
- d) An electric motor taking a current of 5A at 240V is connected by cable to a generator some distance away. If the p.d at the terminals of the generator is 250V, calculate
- The resistance of the cable
 - The power supplied by the generator and loss of power in the cable.
15. a) A bar magnet is placed with its axis along the magnetic meridian with its south pole pointing north.
- Sketch the magnetic flux pattern near the magnet in the earth's field.
 - With reference to the sketch, explain what is meant by a neutral point in a magnetic field
- b) i) Describe an experiment to determine the magnetic field pattern of a bar magnet using iron fillings.
ii) State one advantage and one disadvantage of the method in (b) (i).
- c) Describe how the earth's magnetic meridian may be determined.
- d) A galvanometer has a coil of resistance 8Ω and gives a full scale deflection when a current of 0.5mA is supplied. Calculate the resistance that can be used to convert it into an ammeter measuring up to 5A.

Ans: [8.0 × 10⁻⁴Ω]

16. a) i) What is a magnetic field
ii) State the law of magnetism
- b) i) Explain with the aid of a diagram how a steel bar can be magnetized by the single touch method.



- ii) Sketch the magnetic field pattern around two bar magnets whose north poles face each other.
17. a) With the aid of a labeled diagram describe how a simple ac generator works
 b) Explain with the aid of a diagram what happens when two vertical, parallel conductors are placed near one another and carry current in
 i) The same direction
 ii) The opposite direction
 c) i) Describe with the aid of a diagram, how a direct current generator works
 ii) State three ways of increasing the emf produced by the generator
18. a) What is meant by magnetic saturation
 b) Explain why freely suspended bar magnet swings until it points North South.
 c) With the aid of a diagram explain the use of magnetic keepers.
19. a) State any two factors which determine the magnitude of the emf induced in a coil rotating in magnetic field.
 b) i) Draw a diagram to show the construction of a step-down transformer
 ii) A transformer is used to step-up an alternating voltage from 20V to 240V. Calculate the number of turns in the primary coil if the secondary coil has 1200 turns.

Ans: [100 turns]

20. The figure shows a circuit

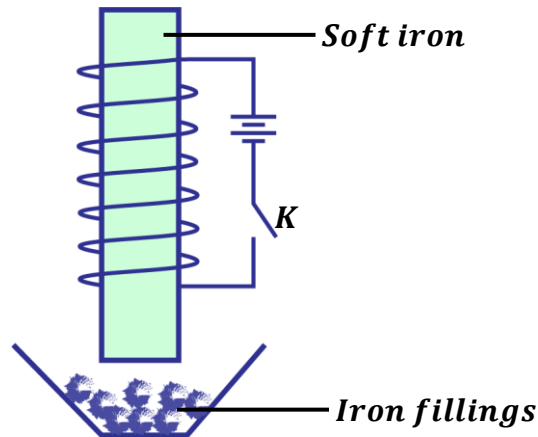

- a) Describe what is observed when the key, K, is closed
 (i) Closed
 (ii) Closed and then again opened
 b) State two ways by which the effect of what was observed in (a) (i) above can be increased.

