

NAME:..... STREAM:.....

456/1
MATHEMATICS
Paper 1
2025
 $2\frac{1}{4}$ hours

STUDENT INFORMATION				
RANDOM NUMBER				
PERSONAL NUMBER				

MENGO SENIOR SCHOOL
UGANDA CERTIFICATE OF EDUCATION
MOCK EXAMINATIONS 2025
MATHEMATICS

Paper 1

2 hours 15 minutes

INSTRUCTIONS TO CANDIDATES:

*This paper consists of **two** sections; **A** and **B**. It has six examination items.*

*Section **A** has **two** compulsory items.*

*Section **B** has **two** parts; **I** and **II**. Answer **one** item from each part.*

*Answer **four** examination items in all.*

*Any additional item(s) answered will **not** be scored.*

*All answers **must** be written in the answer sheets provided.*

Graph paper is provided.

Silent, non-programmable scientific calculators and mathematical tables with a list of formula may be used.

SECTION A

Answer **all** items in this section

ITEM ONE

Titus Junior School is planning a fund-raising day to build a small science lab. Their goal is to raise two million twenty thousand two hundred shillings only. Students from three classes, S.2, S.3, and S.4 are given targets in the ratio 2:3:5 based on their class size.

One of the sources of money was to be from selling items where each student in S.4 makes $1.3\overline{18}$ items, and there are 44 students in that class. Every item will be sold at UGX 1,000. Buyers who purchase more than 5 items get a 10% discount on each of the items in excess of 5 items.

In addition to items, the school canteen sells drinks and snacks where each bottle of drink costs 1200 UGX and each snack costs 700 UGX.

The flyer designed for the event displays the total number of items using the code written in ternary base as 111001 items. The number of items that were made by the S.4s was two seventh those that were made S.3s and the rest of the items displayed on the flyer were made by S.2s.

Tasks:

- a) Determine the difference between number of items that were made by S.2s and S.4s.
- b) Divide the target amount of money among S.2, S.3, and S.4 using the ratio 2:3:5 given that the class size was equivalent to the number of items made.
- c) If a buyer purchases 56 items, how much does he pay?
- d) If Mr.El-Shadai took 40,000 UGX to buy drinks and snacks for his friends, determine the maximum number of bottles of drinks and snacks that were bought if equal amounts of money were spent on each hence find the balance that he was given.

ITEM TWO

Anitah and Juliet are two teachers in Kiryatete village, Hoima district. Last year, they started a poultry farm project to enhance their income. On 1st January, 2024, they bought 150 birds and they wish to know how the population of birds changes after every one month. On consulting a specialist, they were told that the number of species they rear doubles by the end of every one month. In addition, they provided shelter to the birds by constructing a coop where they fixed poles at positions A(1,7), B(3,11),C(2,4) and D(5,10). They also bought 3 iron sheets and 15 poles at a total cost of Shs.165000, and these were not enough thus they ended up buying more 2 iron sheets and more 3 poles costing Shs.75000 altogether.

Tasks:

- a) Help Anitah and Juliet to estimate the population of birds on 1st May 2024 if 4% of the birds die at the beginning of every new month.
- b) When will the population of birds reach 4080?
- c) i) Determine the equation of a line connecting two poles A and B hence or otherwise justify whether poles C and D are parallel with A and B,
ii) If an electrician wants to put a pole at a position where a wire from B to D meets another wire from C to A, where should the pole be fixed?
- d) Determine the price of 8 poles and 7 iron sheets.

SECTION B

This Section has two Parts; I and II

Part I

Answer *one* item from this part

ITEM THREE

During inter-house athletics trials at Mengo Senior School, some S.4 students took part. The coach tracked their performance during the races and also observed their participation across different events.

From the records, Apolot and Teretha participated in both the 100m and 200m races, Teretha and Magembe took part in the 200m and 400m races, Atwine and Collins only participated in 100m race, Ninsiima and Vashty took part in 100m and 400m races but did not take part in 200m race. However, Kokan who is a well-known star had an injury and did not participate in any of the races. Meanwhile, the coach monitored Magembe and Teretha's performances during the 400m sprint using a tracking equipment and according to the data; Magembe started from rest and increased his speed steadily for 8seconds until he reached 8m/s, he kept the pace for 32seconds and then steadily increased and covered the remaining distance in 10seconds. Teretha also started from rest and increased her speed steadily and reached 10m/s after 20 seconds, she maintained this speed for 25seconds and reduced her speed gradually to cover the remaining distance in 20seconds.

Tasks:

- a) With the aid of a clear diagram, help the coach to find out who took part in;
 - i) at least two races
 - ii) at most one race
- b) i) Based on the Coach's data, if Magembe and Teretha set off at the same time; who of the two reached earlier than the other and with which speed did he/she reach at the end point?
 - ii) determine the time and the position when they were running at the same pace.
- c) Do you support schools to involve S.4 students in athletics, why?

ITEM FOUR

During a school health week, the science club conducted a survey on the average number of hours students sleep per night. They recorded data from 100 students and grouped the responses as follows.

Sleep Duration(hours)	3.0 – 3.9	4.0 – 4.9	5.0 – 5.9	6.0 – 6.9	7.0 – 7.9	8.0 – 8.9
Number of students	8	14	25	35	12	6

They found out that all those students that sleep for less than 4.5 hours over dose in class, those that sleep for more than 6.8 hours don't perform well and those whose sleeping time is between the average and most likely number of hours are always stress free and very active in class.

Unfortunately, Mr.Ssenteza, the secretary, of the club lost one of the papers where they had written the total time in hours spent by students of the previous year while sleeping on a particular day. All he could remember was that it was a four-digit number where if the digits are arranged, their median was equal to the range but it was twice the smallest digit which was equal to the difference between the middle two digits. He also noted that the product of the two smallest digits would yield the biggest digit.

Tasks:

- a) Help the science club to determine the number of students who:
 - (i) Dose in class.
 - (ii) Don't perform well
 - (iii) Are very active in class
- b) Determine the probability that a student chosen at random sleeps for at least 6hours.
- c) Help Mr. Ssenteza to recall the four-digit number if it is the smallest even number that can be formed by the digits.

Part II

*Answer **one** item from this part*

ITEM FIVE

Mr.Muyanja has a piece of land in Namayumba that he reserved for cattle keeping. He intends to install a dam at a point that is equidistant from all corners of the land. The land is in triangular form with angles in the ratio 4:3:5 and one side measuring 700m.

However, due to increased insecurity, he intends to gazette the land with barbed wire passing through all the corners of the land.

Given that Mr.Muyanja is a civil servant earning a gross pay of ten million, five hundred thousand one shillings per month and is entitled to the following monthly allowances

Children: Shs.15000 for each child aged 12 years and below, Shs.12000 for each child between 15 years and 18 years inclusive.

Lunch: Shs.2000 per day, transport: Shs.110000 per months, medical: $\frac{1}{25}$ of the gross monthly income per month, marriage: $\frac{1}{10}$ of the gross monthly income per month and housing: $\frac{1}{100}$ of the gross annual income per annum.

Mr. Muyanja is married with five children aged 18 years, 11 years, 21 years, 24 years and 10 years. The following income tax structure is followed to follow up the taxes one has to pay.

Taxable Income (Shs.)	Tax rate (%)
30000 and less	Free
30001-130000	8.0
130001-260000	14.5
260001-380000	23.0
380001-490000	28.5
490001-590000	35.0
Above 590000	42.5

Tasks:

- a) Help Mr. Muyanja to determine the distance from the dam to any of the corners of the land.
- b) If he will gazette the land on condition that his net income is at least Shs.4000000, justify whether he will gazette the land hence determine the total cost of the barbed wire needed if 1 meter costs Shs.20000, correct your answer to the nearest hundreds.

ITEM SIX

Albert and Samson organized to meet for a swimming competition. They live 120 km and 100 km away from the swimming pool on bearings of 060° and 320° respectively. They resolved that Albert will use a straight direct route to pick Samson from his home using his car before proceeding to newly renovated pool. The deep side of the pool is 4 m deep while the shallow end is 1.5 m deep as shown below.

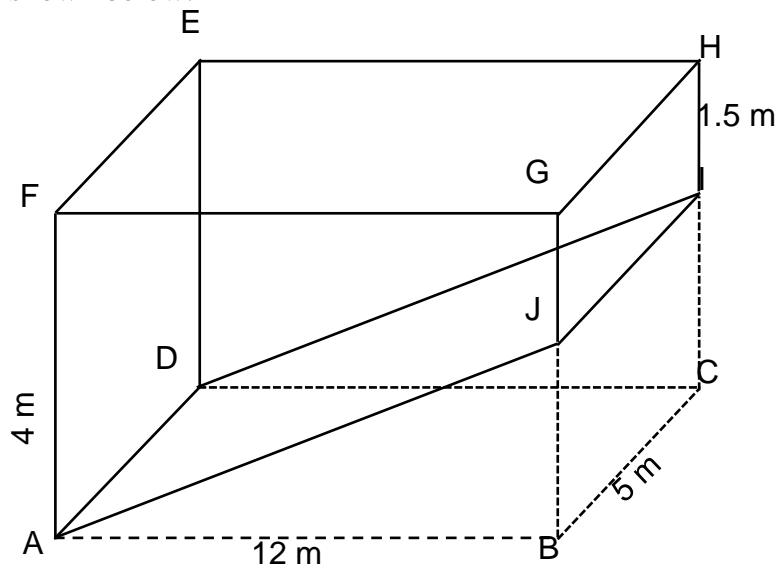

The view of the pool from a helicopter is shown below consisting of two concentric circles with the inner circle circumscribing the rectangular surface of the pool.

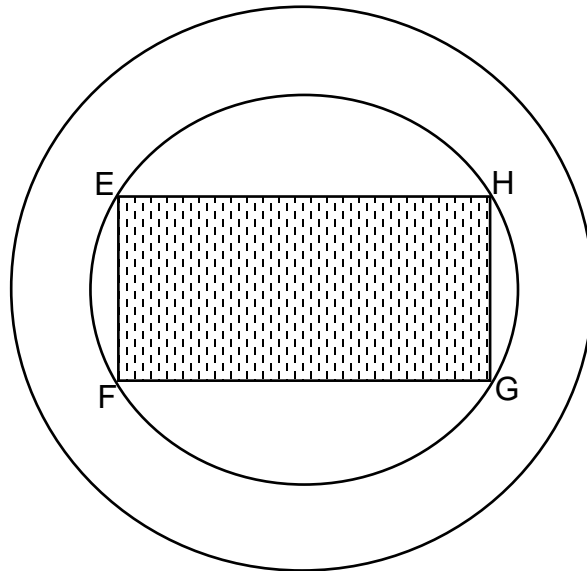

The radius of the outer circle is twice that of the inner one. The un shaded area outside the pool but not exceeding the bigger circular boundary had to be tiled before the competition date using rectangular tiles of dimensions 2 cm by 1.5 cm.

Tasks:

- (a) Help to determine the distance and direction that Albert had to take to pick Samson.
- (b) Recommend the minimum number of tiles required to do the tiling job.
- (c) The inclination of pool above horizontal is recommended to be less than 11.5° to minimize slipping for learners. Is the pool fit for learners or not?
- (d) 2 tins of chlorine water are required to treat 250 litres of water. Help to determine the minimum number of tins required to treat the water in the pool filled with untreated water.

END