

**535/1**  
**PHYSICS**  
**Paper 1**  
**(Theory)**  
**July, 2025**  
**2 ½ hours**



**MATIGO EXAMINATIONS BOARD**

**MOCK EXAMINATIONS**

**Uganda Certificate of Education**

**PHYSICS**

**Paper 1**

**(Theory)**

**2 hours 30 minutes**

**INSTRUCTIONS TO CANDIDATES**

*This paper consists of **two** sections; **A** and **B** It has **seven** examination items.*

*Section **A** has **three** compulsory items.*

*Section **B** has **two** parts; **I** and **II**. Answer **one** item from **each** part.*

*Answer **five** items in all.*

*Any additional item(s) answered will not be scored.*

*All answers **must** be written in the booklets provided.*

## SECTION A

*Attempt all items in this section*

### Item 1

The aspiring member of parliament of your constituency has organised a health camp in your area to sensitise the people about the different health issues related to seeing complications experienced by people **and** also to specifically donate some equipment to the boda-boda riders for use on their motorcycles in a bid to reduce accidents on the roads.

During the presentations, different reactions and observations are made by some of the attendants and noted by the aspiring member of parliament.

- ONE attendant noticed that the projections on the large screen in front are not clearly seen when he is in front and close to the screen but they become clear when he steps behind yet the hall is well lit and the projections are appropriate.
- Most of the people are complaining that the presenters are not heard clearly as the sound seems confused and unclear.
- ONE boda-boda rider requested for some mirrors to use while riding and in the front light system as the ones originally on the motor cycle were spoilt when it fell.
- Some people attending are worried that the sound produced by the loud speakers in the hall could pose risks to their ears.

**Figure 1** shows the electrical wave signal that produces the sound wave and **figure 2** shows the rarefactions and compressions produced by the sound wave heard. **Figure 3** shows some of the equipment available for donation.

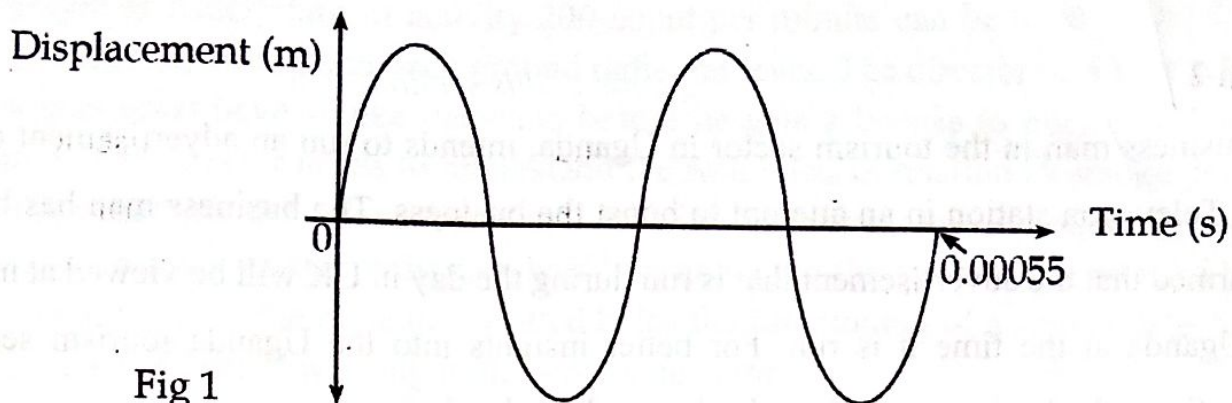

Fig 1

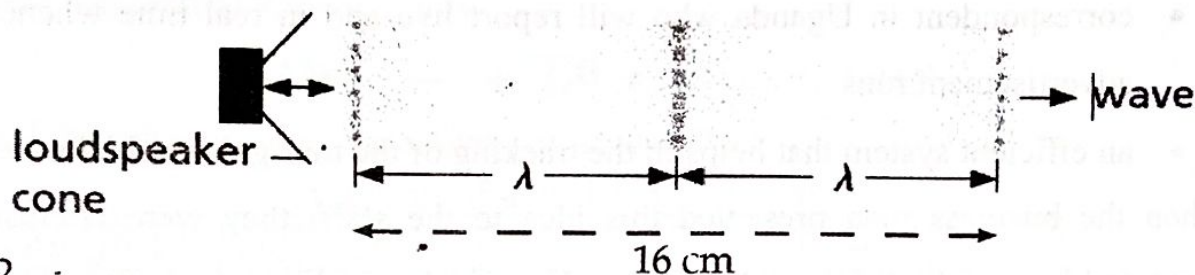

Fig 2

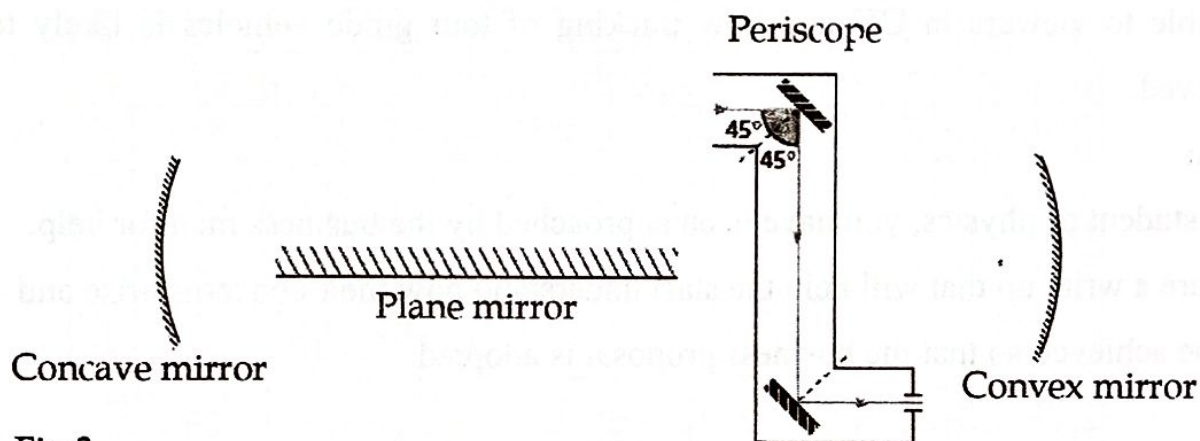

Fig 3

**Hint:** Audible frequency range = 20 - 20000 Hz

Use speed of sound in air =  $330 \text{ ms}^{-1}$

**Task:**

As a student of Physics, help the aspiring member of parliament to:

- understand the attendant's problem and how it can be solved.
- understand why the sound seemed confused and unclear
- select the most appropriate equipment to donate to the boda-boda rider.
- understand whether the sound produced posed risks to the attendants' ears.

## Item 2

A business man in the tourism sector in Uganda, intends to run an advertisement on a UK Television station in an attempt to boost the business. The business man has been informed that the advertisement that is run during the day in UK will be viewed at night in Uganda at the time it is run. For better insights into the Uganda tourism sector attractions, the business man has also been advised to have:

- correspondent in Uganda who will report live and in real time whenever the advertisement runs.
- an efficient system that helps in the tracking of the tour guide vehicles.

When the business man presented this idea to the staff, they were confused and wondered how night in UK is day time in Uganda, how a live broadcast in Uganda is possible to viewers in UK and how tracking of tour guide vehicles is likely to be achieved.

### Task:

As a student of physics, you have been approached by the business man for help. Prepare a write up that will help the staff understand how their concerns arise and can be achieved so that the business proposal is adopted.

## Item 3

*Smoke detectors are increasingly becoming an important device in domestic kitchens, public buildings like school dormitories, hotels and offices. The material used in smoke detectors is Americium-241 because it emits a highly ionising radiation. If you open a smoke detector to replace a battery, you may see a yellow and black hazard sign below:*



A sample of Americium of activity 200 count per minute can be used in the detector until its activity reduces to back ground radiation level. The director of a new school in your area must have smoke detectors before he gets a license to operate a boarding section. The director needs to understand the following in relation to smoke detectors as mentioned in the above context: Ionising radiation, the radiation emitted by Americium, back ground radiation, half-life, how long the sample will be used before it is replaced, how the radiation emitted helps the functioning of a smoke detector and why there is a hazard warning in the smoke detector.

The half-life of Americium =  $(1.92 \times \text{the half-life of P})$ .

The decay equation of Americium is

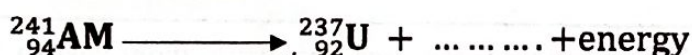

The graph below represents, the activity of isotope P.

A graph of activity against time

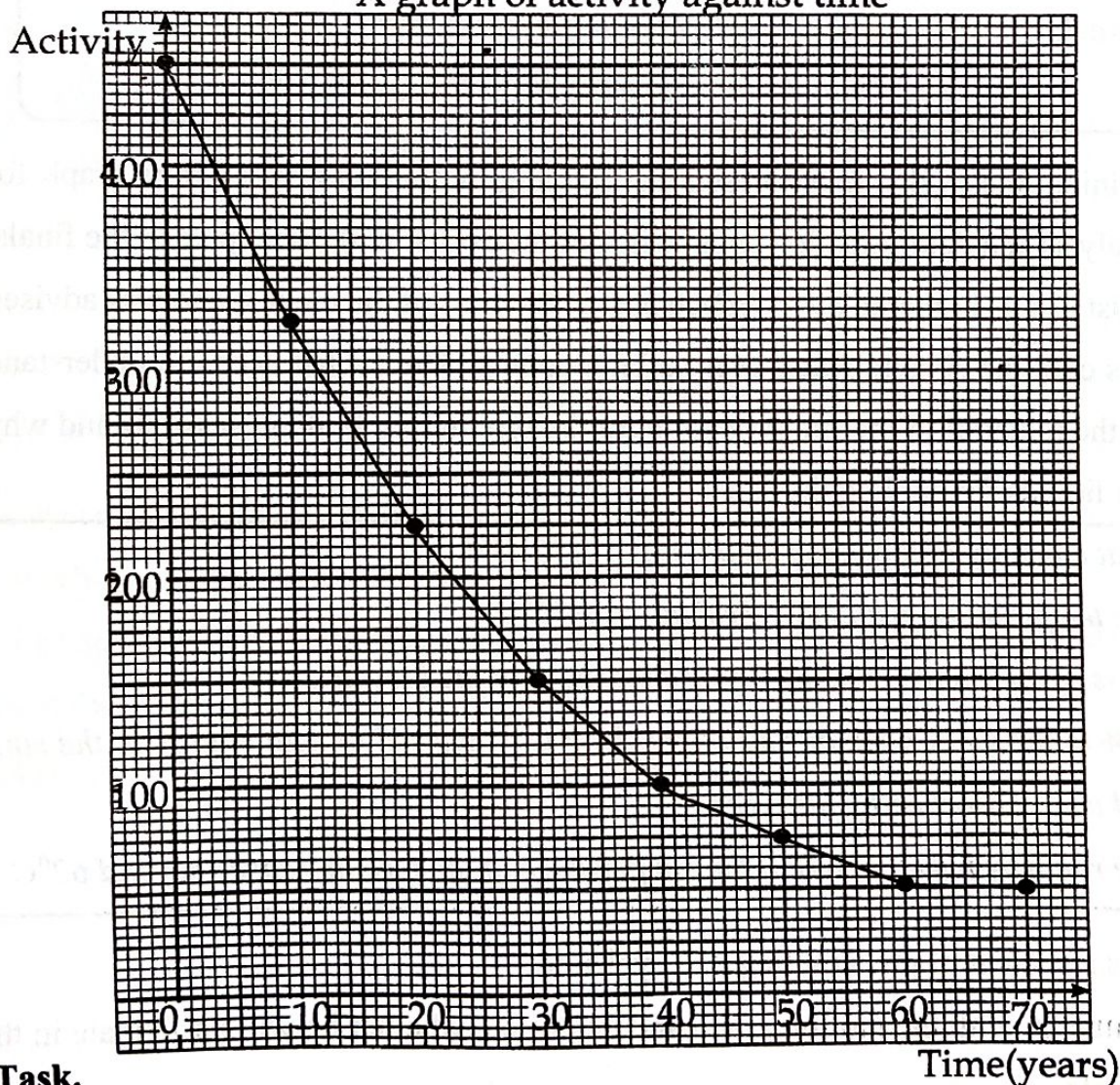

**Task.**

Help the school director with all the information in regard to the challenges faced.

## SECTION B

### PART 1

*Answer one item from this part*

#### Item 4

The organizers of bicycle racing competitions have set a distance of **5000 m** and an average speed of **10 ms<sup>-1</sup>** as the minimum standards for participation in the final competitions. During the training session, a certain racing cyclist's journey is in three stages.

*Stage 1: The cyclist accelerates uniformly from rest to 12 ms<sup>-1</sup> in 20 s.*

*Stage 2: The cyclist cycles at 12 ms<sup>-1</sup> for a distance of 4800 m.*

*Stage 3: The cyclist decelerates uniformly to rest.*

*The whole training journey takes the cyclist 500 s.*

After training, the cyclist must present the training motion on a speed time graph for quick analysis and determination about whether the cyclist will participate in the finals. The cyclist is also bothered by too much heat in the rims of the bicycle and was advised to always cool the rims in water every after stopping. The cyclist needs to understand whether the material of the rim will not burn the tyre during braking sessions and why not other liquids for cooling the rims.

*Heat capacity of the material of tyres = 210 JK<sup>-1</sup>*

*The temperature just before braking = 48°C.*

*Mass of the cyclist = 65 kg, Ignore the mass of the bicycle.*

*20% of the work done during the braking is converted to heat energy in the rims and is all absorbed by the tyres.*

*The rim may burn the tyre if the temperature of the tyre increases beyond 62°C*

**Task:** As a student of physics, help the cyclist to:

- (a) come up with the motion graph and determine whether he will participate in the finals.

- (b) understand the source of heat in the rims and why water is the best for cooling the bicycle after braking.
- (c) Determine whether the rim material will not burn the tyres.

**Item 5**

In a certain ware house, the system that is used to lift a packing case of goods from the ground to a higher level is shown in **figure 4**.

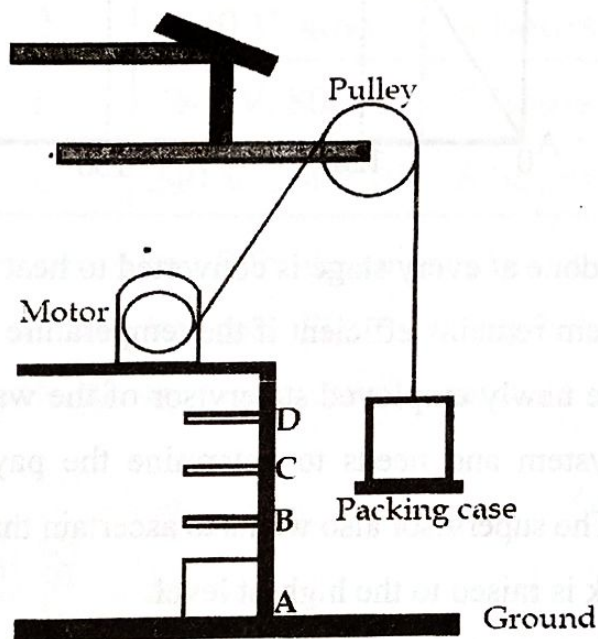
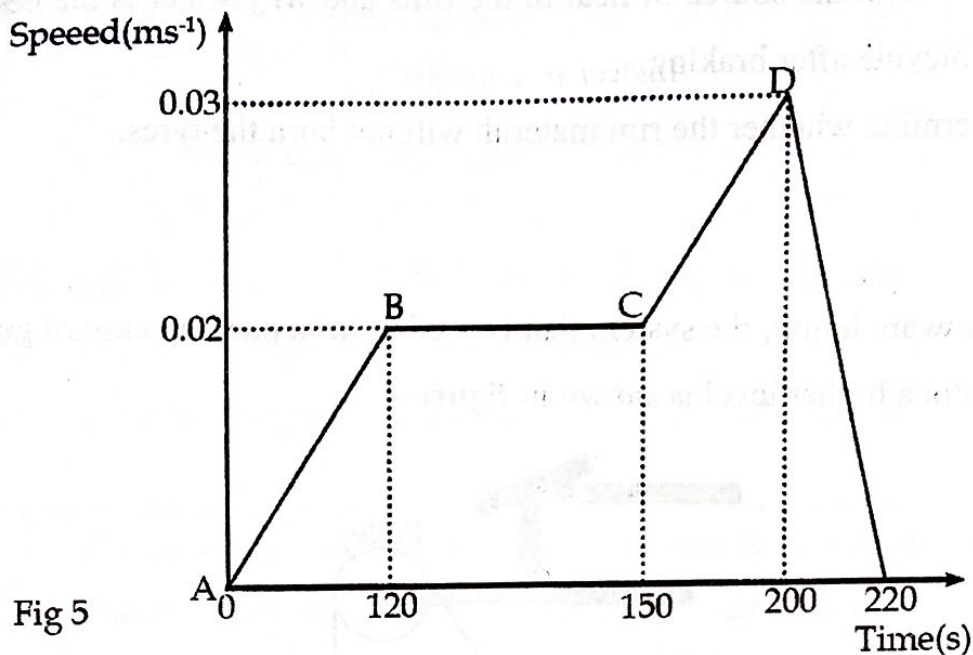

Fig 4

The system is monitored by a computer software that presents the motion of the pack from which analysis is made before payment to the worker is done. Payment is based on the useful work done at every stage where the pack may be required and Ugsh.10,000 is paid for every 1,000 J of useful work.

**Figure 5** shows the motion of a pack of 850 kg worth of goods.



30% of the total work done at every stage is converted to heat energy at the pulley and motor points. The system remains efficient if the temperature change does not exceed 20°C at the points. The newly employed supervisor of the ware house is bothered by the working of the system and needs to determine the payment of the worker as presented in figure 5. The supervisor also wants to ascertain that the system will remain efficient when the pack is raised to the highest level.

As a student of physics, help the supervisor:

- Understand how the system lifts the pack of goods from lower to higher levels.
- Why the motor and pulley points gain extra heat when the system is working and how this may be minimised.
- Whether the system remains efficient.
- Compute the worker's payment.
- Briefly describe one other application of such a system in daily life.

**Hint:** Heat capacity of the material of at the motor point = 480 JK<sup>-1</sup>

## PART II

*Answer one item from this part.*

### Item 6

A salon owner intends to have a provision for the electrical appliances shown in **table 1** in one of the rooms in the building.

Appliance	Number of items	Rating	Run time per day	1 KWh costs sh. 1000
Bulb	2	240 V, 40W	9 hours	
Fan	1	240 V, 800W	5 hours	
Heater	1	240 V, 1000 W	6 hours	

She contacted two electricians **A** and **B** for the circuit plans so that she could pick the one who will do a good job at a less cost. **Figures 6** and **7** show the circuit plans as presented by the two electricians and their respective costs are indicated.

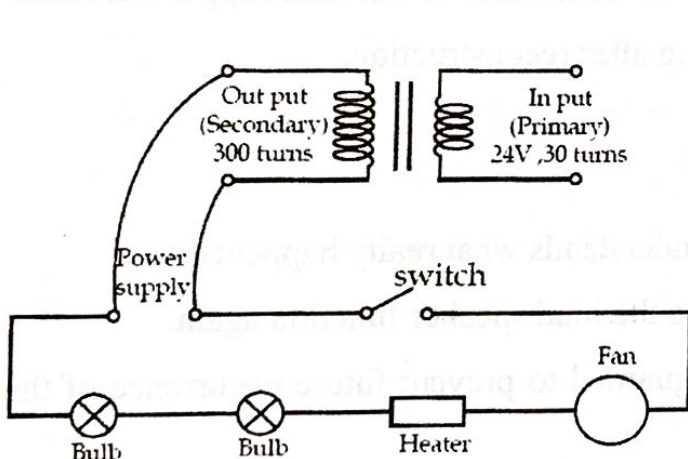

**Fig 6**  
Presented by A at sh. 300,000

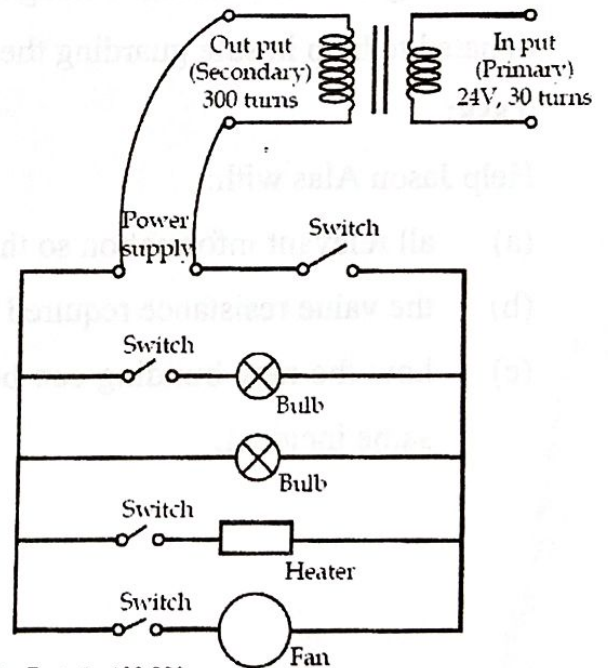

**Fig 7**  
Presented by B at sh. 400,000

Apart from the switch, both electricians included a new device the owner had not thought of. The salon owner intends to spend a maximum of sh. 400,000 on the appliances every 30 days.

She is confused and needs help in understanding the importance of the new device, how it works and whether it is needed in her case, how to select the best circuit plan, and whether her budget will run these appliances as planned.

**Task:**

Help the salon owner with all the relevant information that will help her in resolving all the challenges she is faced with.

**Item 7**

“Out of nowhere, we heard like a thunderstorm” witness Jason Alas said. “It was like really, really loud”. “And all of a sudden, the building housing the offices was on fire burning.” “I really don’t understand what happened”. After the incident, Jason Alas donated a faulty loud speaker rated 108 W, 240 V for use in community mobilisation for building materials in an attempt to rebuild the burnt building. It was later discovered that the loud speaker needed a small size resistor that could allow a current not exceeding 13 A to function well again. Two darkened rods of iron and copper were also donated to help in safe guarding the building after reconstruction.

**Task:**

Help Jason Alas with:

- (a) all relevant information so that he understands what really happened.
- (b) the value resistance required to make the loud speaker function again.
- (c) how the new building can be safe guarded to prevent future occurrence of the same incident.

**END**