

KAMSSA SENIOR SIX SELF STUDY WORK

GENERAL PAPER

DAY 1

SECTION A

Merged by; Musamali Joel MUSESE SSS

2023/10/19

It usually consists of topics based in the following areas, one could be historical, environment, social media, social life, politics, economical aspects, literature, language, Art and craft / culture, science, diseases etc.

MARKS FOR SECTION A

Spellings	05
Grammatical / expressions	10
Definitions	05
Content	30
TOTAL	50

Every point in the content takes three marks. A candidate is expected to mention a point with a sentence explain the point and give **examples** relating to the point.

M – Mention

E – Explain

E – Examples

SECTION A

TERMINOLOGIES USED IN SECTION A QUESTIONS

Account for: Give reasons for something with explanations e.g. Account for the rampant drug abuse in high schools.

Discuss:

It means carefully analyse and examine an issue. Be complete and give details if there are two sides to talk about and give a balanced conclusion. E.g. Discuss the increase in number of teenage pregnancy.

Assess: It means to examine closely with a view of measuring or weighing up a particular situation. Consider a balanced way; strength and weakness for points for and against. E.g. Assess the impact of swamp reclamation on the environment.

Analyse; It means to study in depth, identifying and describing in details e.g. Analyse the role played by youths in the development of your country.

Justify; Means to prove, make a case or give reasons for the decision or conclusion or take an effort to convince e.g. polygamy should be Abolished Justify the statement.

Examine; Look at an idea or situation from both sides. Draw critically a personal opinion.

To what extent; Here we show much a given expression or situation or factor contributes to the occurrence of a final event. The factor in this case may not be the only factor leading to the occurrence of the event therefore other factors must be considered.

Why; Here we give reasons for or purpose for an event or situation.

Trace: Here we describe in a narrative from the progress, development or sequence of events from the point of origin.

Describe; In this case we give a recount, characterise or relate in sequence or stay form.

Evaluate; Here we carefully upraise the issue at hand sitting both hands i.e. advantage and disadvantages, reasons for and against bring out views of authority as well as your personal judgement.

Illustrate; Means demonstrating or classifying a problem or situation by explaining either using figures, diagrams or specific examples.

Explain; Here we clearly interpret and spell out the materials giving reasons for important features or development.

Compare; Here we look for the characteristics that are similar but we should also put in to account the point of difference.

ESSAY WRITING

An essay is a piece of writing presenting a certain topic or an argument, expressing the writer's knowledge, views and opinions of the topic.

It does not require a title and therefore does not require subtitles. In many cases, students tend to express their "views" or "points" by writing subtitles however this is punishable by awarding of a zero.

General paper essays are argumentative. There are decisions of certain topics and mature reasoning is expected at this level following the rubric of the question.

When writing the general paper essay, the following are important.

- Choose the question you know something about in other words choose a question that you familiar with.
- Identify the key terms. This means you know what begins an essay (definition).
- List down all the possible points answering the question.
- Reflect and get the top quality points.

NB:

We aim at getting quality points therefore start with the best quality points. Make sure that the points are stated with the most notable ingredients.

An essay comprises of three basic parts and that is; introduction, body, conclusion.

CHARACTERISTICS OF AN INTRODUCTION

There must be a definition of the key words or terms

Contextualisation of key terms to the Uganda situation

Link the introduction to the body.

NB: The introduction must be in one traditional paragraph and it carries marks.

Sample of an introduction

QUESTION

“Politics is a dirty game” Discuss

Politics is the act of leading and influencing a given group of people in a society. In Uganda today, there are various political parties due to the fact that Uganda is a multi-party nation with democracy. These political parties include National Resistance Movement (NRM), Democratic Party (DP), Uganda people’s Congress (UPC).

BODY

The body comprises the core of the student’s argument.

It has the point or points of discussion of the topic at hand.

Each point must have a separate or independent paragraph.

The paragraph marks the beginning of the new points so there is no need of numbering of bulleting.

Do not skip lines as this will be considered disjointed work which may or will lead to loss of marks.

Each point must start with a topical statement. A topical statement is the sentence where the argument is clearly stated bearing in mind the question at hand.

Do not hide the points / arguments. State it in black and white in the first sentences of the paragraph.

Always strength your points by explaining in details in relation to the question.

CONCLUSION

The function of the conclusion is that it restarts the main argument.

It reminds the reader of the strengths of the argument that is, it reiterates the most important evidence supporting the argument.

Make sure, however, that your conclusion is not simply repetitive summary as this reduces the impact of the argument you have developed in your essay.

The conclusion should match the introduction in terms of the ideas presented and the argument put forward.

HIV / AIDS

EXAMPLE

What are the causes and effects of HIV/ AIDS?

HIV is Human Immune Deficiency Virus which causes a disease called Acquired Immune Deficiency Syndrome and this disease can generally lead to death and other health problems in case one misuses the drugs given to him or her. The cause of HIV / AIDS and effects may include the following;

HIV / AIDS is transmitted through sharing sharp objects with an infected person and here most people who are infected with HIV/AIDS in most cases want to spread the disease so they decide to use sharp objects such as razorblades, safety pins among others and share them with the people who are not affected knowingly.

Having unprotected sex where by a person who is not affected with the disease has sexual intercourse with a person who is affected especially this is among old men who cheat on their wives and later on the contract the disease so they also want to spread the disease through lying school going children especially the girls thus ending of spreading the disease.

Unfaithfulness among partners where by one or both partners do not trust in themselves. In most cases one of the partner may be having the disease and may not express him or herself thus end up spreading the disease to the fellow partner.

Permissiveness is yet another cause of HIV / AIDS where people below the age of eighteen (18) do whatever they feel like at any one time hence end up having sex with unprotected people thus contracting HIV /AIDS.

Improper handling of the umbilical cord of the mother during birth. If the mother is HIV positive, the blood of the mother may end up mixing with that of the baby hence the baby also ends up contracting the disease.

PACKAGE 1

Choose one question below and write an essay of between 500-800 words.

1. Examine the causes and effects of landslides in Uganda.
2. Explain the challenges of teaching vernacular in lower primary classes in Uganda.

DAY 2

1. **Analyze the causes and suggest solutions to the problem of Human Trafficking in Africa. (50 marks)**

Human trafficking refers to the action or practice of illegal transporting of people from one country or area to another typically for the purposes of forced labor or sexual exploitation.
Or

Human trafficking involves recruitment, harboring or transportation of people into a situation of exploitation through the use of violence, deception or coercion and forced to work against their will. People can be trafficked for many different forms of exploitation

such as forced labor, forced prostitution forced begging, forced criminality, domestic servitude, forced marriage and forced organ removal.

Causes

- ✓ Law enforcement that lacks the training to cooperate with neighboring countries in order to prevent and interrupt this crime.
- ✓ Leaving a place of poverty to gain wealth
- ✓ Political conditions.
- ✓ War
- ✓ Social and cultural practices.
- ✓ Lack of education
- ✓ Demand for cheap labor/demand for sex
- ✓ Lack of Human rights for vulnerable groups
- ✓ Lack of legitimate economic opportunities
- ✓ Conflict and natural disasters
- ✓ Human trafficking generates a large profit
- ✓ Lack of safe migration options
- ✓ Existence of human traffickers
- ✓ Immigrants that are attempting to reach Europe, the Middle East and Italy.

Solutions

- Every nation needs to build its own regulatory platform against money laundering
- Adoption of global standards is important. We need to learn lessons from how the international community has come together to combat the smuggling of refugees across the Mediterranean.
- Intelligence gathering and a concerted effort to identify unusual payments or employment conditions.
- Laws and regulations are an important step but they are useless if they are not working.
- African countries need to work together to develop and implement new monitoring techniques specifically tailored to detecting human trafficking.
- Judicial reforms that would allow victims to demand strong penalties for traffickers
- Rehabilitation of trafficking victims.
- Assess the needs in your country.
- Form partnerships
- Be careful not to disempower the survivors.

MA

Definition- 05 marks

Content-any five causes 5 points 3 marks @, any five solutions 5 points 3 marks@=30 marks

General Expression-10 marks

Spelling-05 marks

(A total of 50 marks)

ACTIVITY 2

Choose one question below and write an essay of between 500-800 words.

1. Analyse the major causes of refugees in the great lakes region and suggest the solutions to avert it.

2. Analyse the merits and demerits of private schools in Uganda.

DAY 3

2. "Human beings have been solely responsible for environmental degradation." Discuss.
(50 Marks)

Environmental degradation refers to the decline in the quality and characteristics of the natural surroundings of man which includes: animals, land, water, forests and plant species.

Or

It refers to the deterioration of the available renewable and non renewable natural resources. These resources lose the quality and quantity and gradually disappear. Examples include; forests, swamps.

Human beings have a bigger contribution towards environmental degradation in Uganda. However, there are other factors

Human beings contribution

- Poor farming methods like over grazing which destroys the grasslands lead to soil erosion.
- Over cultivation /use of land in densely populated areas like Kigezi.
- Swamp reclamation by man to give way for settlement
- Clearing of forests/deforestation to provide timber, charcoal, firewood.
- Rapid industrialization especially in urban centers leads to air pollution/dangerous gases emitted.
- Poor garbage /industrial waste disposal pollute land/soil.
- Mining/quarrying activities affect the environment for example Tororo.
- Construction of roads along steep slopes leads to soil erosion and landslides.
- Poor fishing methods like over fishing, use of poison.
- Cars /vehicles emit nitrogen oxide and carbon dioxide into the atmosphere.

Other factors responsible for environmental degradation

- ✓ Heavy rainfall/floods/el nino rains
- ✓ Natural factors such as drought which affects man, crops animals for example Karamoja.
- ✓ Hail storms that destroy crops.
- ✓ Earth quakes destroy agricultural land and kill people.
- ✓ Volcanic eruptions, mass wasting and landslides.
- ✓ Weeds (water hyacinth) pests and diseases also affect the environment.

MA

Definition- 05 marks

Content- any 6 points 3 marks@ as human beings are responsible for environmental degradation, other factors 4 points 3marks@ = 30 marks

General Expression- 10 marks

Spelling- 05 marks (A total of 50 marks)

ACTIVITY 3

Choose one question below and write an essay of between 500-800 words.

Neat work is a must.

1. Discuss the causes of conflicts in Africa and how they can be solved.

4. Discuss the contribution of smoking to your community.

DAY 4

3. Elaborate on the key causes and effects of the current practice of Female Genital Mutilation (FGM) in some African countries. (50 marks)

Mutilation (FGM) in some African countries

FGM is the practice, tradition in some cultures of partially or totally removing the external genitalia of girls and young women for non-medical reasons. It is illegal in many countries.

Causes

- Low levels of literacy, "it is what others do and what we have always done."
- Social pressure and a desire not to stand out as a rebel are a powerful force.
- In some societies women who have not undergone through FGM are not allowed to handle food and water because they are unclean and seen as a health risk to others.
- It is a way of preparing a girl for marriage and adult life.
- In some cultures, people believe that an uncut clitoris will grow to the size of a penis or that FGM makes a woman more fertile.
- FGM is linked to virginity and being faithful in marriage
- Femininity and modesty can be a key factor in some societies, a woman is perceived to be cleaner and more beautiful if her genitalia are cut.

Effects

- ✓ Violates a person's right to health, security and physical integrity.
- ✓ One is subjected to torture.
- ✓ FGM is a cruel culture.
- ✓ It leads to death as one is denied a right to life.
- ✓ One is subjected to inhuman or degrading treatment.
- ✓ Severe pain, possibly leading to loss of consciousness.
- ✓ Urine retention and other urinary problems.
- ✓ Open sores in the genital area.
- ✓ Bleeding.
- ✓ Bacterial infection.
- ✓ Damage to nearby genital tissue.
- ✓ Higher rate of childbirth complications
- ✓ Increased risk of new born deaths.
- ✓ Infertility.

MA

Definition-05 marks

Content-causes 05 points 3 marks, effects – 05 points 3 marks @=30 marks

General Expression-10 marks

Spelling-05 marks

(A total of 50marks)

ACTIVITY 4

Choose one question below and write an essay of between 500-800 words.

Neat work is a must.

1. Elaborate on the low level of technology in undeveloped countries of Africa.
2. Elaborate on the rampant political turmoil a factor of moral decadence in Uganda?

DAY 5

4. Explain the challenges faced by Uganda's Education system and suggest possible solutions to these challenges. *(50 marks)*

The system of Education in Uganda has a structure of 7years of Primary education, 6years of Secondary education (divided into 4years of lower secondary and 2years of upper secondary and 3-5 years of post-secondary education). The government of Uganda recognizes education as a basic human right and continues to strive to provide free education at primary and secondary levels to all children.

Challenges facing Uganda's education system

- Inadequate budgetary resources.
- Capacity gaps in education
- Social and cultural practices.
- Inadequate physical infrastructure
- Inadequate sports facilities and equipment
- High level of teacher and student absenteeism
- Weak school level management structures
- Inadequate availability of learning materials and large class sizes
- Lack of accommodation for teachers in rural –hard to reach areas.
- Poor remunerations
- Teenage pregnancy
- High school dropout rate

Solutions

- ✓ Creating a functioning scheme of service that links teacher and all education officials' promotion to performance
- ✓ Overhauling the entire teacher payroll system so that teachers are paid on time and the so called 'ghost teachers' are removed.
- ✓ Investing in inspection and ensuring that the follow up is rigorous
- ✓ Pay teachers a decent salary
- ✓ Need to construct classrooms and teachers quarters.
- ✓ Cost sharing model in which both parents and the government contribute to the funding of education.
- ✓ Pupils or students with a passing mark can be promoted
- ✓ Recruitment of teachers
- ✓ Overhauling the curriculum of education in order to have hands on skills as it will keep learners in school.

MA

Definition- 05

Content-challenges any 5 points@3, any possible solutions any 5points@3marks = 30 marks

General Expression= 10 marks

Spelling= 05 marks

(A total of 50 marks)

ACTIVITY 5

Choose one question below and write an essay of between 500-800 words.

Neat work is a must.

1. Examine the causes and likely consequences of drug addiction
(50 marks)
2. Examine the challenges facing the African culture today.
(50 marks)

SECTION B

It consists of two numbers that is comprehension and logic. Comprehension is an English prose passage which tests the students' ability to re-express themselves in continuous form of the material supplied.

It also tests knowledge and understanding of common English usage.

The logic will test the student's ability to interpret information, logic tests and give logical and scientific reasoning.

LOGIC QUESTION. (QUESTION 5)

EXAMPLE

5. Three prison warders are escorting three prisoners for treatment in Jinja hospital but they have to cross the lake from Bugungu prisons. The canoe they have to use can only carry two people at a time. Of the three prisoners, only one is strong enough to row the boat and is the one trusted by warders, the two prisoners are very ill. The regulations do not allow the prison warders to be out numbered by the prisoners at either side of the lake.

Questions.

- a) Study the information above and draw a pattern of possible travel of the parties involved across the lake. (15 marks)
- b) Account for the overwhelming numbers of prisoners in Ugandan prisons. (10 marks)
- c) Analyze the challenges facing Ugandan prisons. (10 marks)
- d) What has the government done to reduce on crimes in Uganda today? (5 marks)

SPGE = 10

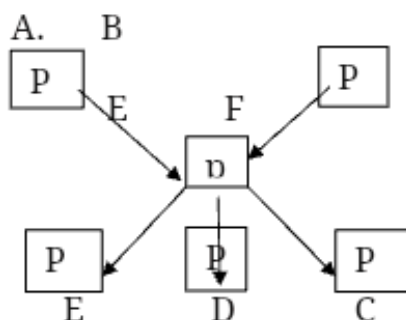

F is the driver

He took the parties across the lake following the alphabetical order A, B, C, D, E respectively one at a time. (15 marks)

B. Account for the overwhelming numbers of prisoners in Uganda prisons.

- ✓ Unemployment
- ✓ The number of young people often young men involved in theft on streets is the rise
- ✓ Increased consumption of narcotics and the potential for these youngsters to graduate to hardcore and violent crimes as they are.
- ✓ Environment of where the children are raised.
- ✓ Poverty
- ✓ Political persecution
- ✓ Hatred and enmity in society.

(Any 5 points) 10 marks

C. Challenges facing Ugandan Prisons

- ✓ Poor feeding
- ✓ Congestion
- ✓ Poor health facilities
- ✓ Denial of a right to vote
- ✓ Delayed appeals in courts
- ✓ Unfair criminal justice system
- ✓ Torturing and threatening of suspects
- ✓ Police does not properly investigate cases.

(Any 5 points) 10 marks

D. What can the government do to reduce on crimes in Uganda?

- ✓ Improve on the health facilities within the prison.
- ✓ Day care centers and maternity clinics should be put in place for the female inmates.
- ✓ Judges should respond to all appeals and cases.
- ✓ Prerogative of mercy given by the President should be given to old inmates to decongest the prisons.
- ✓ Increase the pay to inmates when working out of the prisons
- ✓ Increase the number of judges
- ✓ Torture should be stopped henceforth
- ✓ Construct more prisons to meet the current increasing population
- ✓ Provide decent meals and mattresses.

(Any 5 points) 5marks

SPGE=10 marks

ACTIVITY 6

5. Read the following and answer the questions which follow.

The ministry of Ethics and Integrity is conducting a seminar in Hotel Adolphus designed to help companies improve efficiency in the work place and also reduce corruption. Global Tech Ltd is following five participants to the seminar.

The warden in charge of accommodation is putting the five participants on Block – level which has 5 rooms in a row labeled D2 –A, D2 –B, D2 –C, D2 –D, D2 – E. The best of the rooms is D2 –A and the worst is D2 – E which has toilets and washroom next to it. The following information has been availed to enable him locate the rooms

Turyabe Silver joined the company fresh from the University. He had worked for some years to earn enough money to pay his university tuition. He graduated when he was 27 years old. He is a quiet character, doesn't make friends easily. He had worked for 6 years in the company before Mande Musisi came in.

Muganda Oscar is a decade older than Turyabe and is soon to be retired. He has a large family and is very corrupt man who only thinks about amassing as much wealth as possible before he retires. He joined the company 5 years after Mande Musisi came in.

Mande Musisi is a couple of years younger than Zabedi. They are good friends who work in the same office. He is cautious and serious young man who often cautions his friend Zabedi about his life style. He has spent 15 years with the company.

Zabedi Caliph is a half –caste, play boy type who joined the company in his S.6 vacation when he was 18 years old. He is a handsome man, a womanizer with many girlfriends. He has worked for the company double the time that Muganda Oscar has.

Opio James is responsible for recruiting people in the company. He is also in charge of processing their retirement package. He joined the company as a young trainee of 20 years, a couple of years before Zabedi joined the company.

Questions

(a) The warden made a list (list 1) based on the ages of the five participants in descending order. Whom did he allocate the:

- (i) Best room?
- (ii) The worst room?

(b) He gave the list to his secretary to type and she reversed his decision unintentionally. Whom did he allocate the following rooms in her list? (list 2).

- (i) Room D2 –B?
- (ii) D2-E?

Who remained in the same room on both list 1 and list 2?

(c) A few days later the warden was bribed by one of the participants to be allocated the best room. He therefore made a third list (list 3) based on the number of years which the participants had worked for the company.

- (i) Who called him and bribed him?
- (ii) How were the rest of the rooms allocated?

(d) (i) Explain the causes of corruption in Uganda's society today.

(ii) What are its effects in society?

ACTIVITY 6

5. Study the information below and answer the question.

Bright star S.S. is one school that recorded many cases of crime in the year 2016. This situation was mostly reported in the five boys' dormitories. These included Elgon, Muhavura, Everest, Kirimanjaro and Rwenzori. The situation was so bad that the students threatened to stage a strike if the administration did not intervene. In response to this the school administration was prompted to formulate a committee to investigate the matter and later find solutions to the problem. The investigations were held basing on the following allegations.

Elgon harbored smokers, thieves and boys who took alcohol.

Rwenzori: had lost some of its furniture due to fights and also had obscene speaking boys who liked drinking Waragi.

Muhavura had cases of theft. Some of the boys not only sneaked out of the school to take alcohol but also slept with village girls and used obscene language.

Everest had a few cases of theft

Kirimanjaro had cases of smoking, use of obscene tongue and frequent fights. After through investigations the committee confirmed the following:

Elgon had cases of theft and alcoholism

These were boys in Rwenzori dormitory who had injuries from previous fights while others had drinking problems, smoked and also used obscene language.

Muhavura had cases of boys who had once been caught sleeping with village girls in the dormitory toilets. Some smoked and hurled insults at the wardens.

Everest had theft, cases of fights and a few boys who took alcohol.

Kirimanjaro had some boys who had once sneaked into the girls dormitories to meet their girlfriends.

Questions:

- a) Draw a table showing the findings of the committee. (10 mks)
- b) Give the dormitories that were
 - i) Most affected by indiscipline cases. (01 mk)
 - ii) Least affected by indiscipline cases. (01 mks)
- c) Suggest how schools should effectively handle indiscipline cases by students. (13 mks)
- d) How should students avoid getting themselves involved in crime while at school?

DAY 7
COMPREHENSION
EXAMPLE

Read the passage below and answer the questions that follow.

In class seven, about 100 mostly bare — footed pupils, some without uniform and others dressed in rags, squeeze themselves on a bench in the classroom. They crane their necks to catch glimpse of teacher reading an English essay from a text book.

According to the Ministry of Education, each pupil is entitled to a text book or at worst three pupils are supposed to share a text book during a lesson. But at Bundikkanga Primary School in Bundibugyo District, things are different. "We have one text book for the whole class, so I read for them so that everyone gets chance to use it." The English Language teacher says.

Consequently, more than 90% of his pupils hardly speak English. At the 2009 Primary Leaving Examinations, the School had no first grade. Over 100 pupils were in P.7, but only 40 pupils sat the examinations. The teacher adds that, about 60 pupils drop out. Some get married, others were eliminated because they did not pass the mock examinations and others dropped out due to lack of interest in School.

According to Bundibugyo District Education Office, (BDEO), the District got 66 pupils in first grade at 2009 PLE, out of over 2000 pupils who sat for examinations. Over 600 pupils were either ungraded or failed. Bundibugyo District Education Officer says, the District has not succeeded in getting 80 students in first grade for **almost a decade**. An average of over 2,000 candidates sit for PLE annually and their performance continue to **deteriorate**.

Since the District suffered war at hands of allied Democratic Front. Some parents no longer value education. "The war ended 10 years ago but scars are still felt. Parents no longer value education because many children were not studying during the war even though the government put temporary schools there," adds the BDEO.

The Education Ministry carried out a survey and discovered that over 90% of parents were not interested in children's education but instead had prioritized business, luxurious items and early marriage. During the cocoa harvesting season, three quarters of the children do not report to school because they are helping parents to harvest cocoa.

One Headmaster of a renowned primary school says, an average of 90 pupils out of 530 report to school during the cocoa harvesting season. The situation was made worse when the district administration and communities chose the 15th and :30th of every month for cocoa harvesting. The pupils stay at home and this has affected their studies. In the past, there were only two cocoa harvesting seasons through out the year but due to the changes in the weather, cocoa harvesting is very season. Due to high price of cocoa, many pupils **abscond** from school.

The dropout rate is over 80% annually. Many girls dropout to get married. Out of 100 girls who join primary one, only seven or five sit for PLE. In 2009, six girls sat for PLE out of 40 pupils. The drop out Rate in the district stands at 28% and the dropout rate for primary three

and five, are about 70%. "During the market days, many pupils do not report to school. They instead go to the market to do business," says one parent. This problem is **compounded** by teacher absenteeism. The inspector of schools for Bughendera county states that almost 55% of district is on hilly terrain. It is almost impossible to inspect schools in mountains. Even if you have a vehicle, you have to walk for hours. "We are **overstretched** and yet are paid poorly. Some teachers are absent because they go to other places to look for alternative income. If we stay at the station and wait for salary, we are likely to starve. The government should increase our salary. A teacher who preferred anonymity says. "

The BDEO acknowledges the teachers' problems but says: "why did these teachers accept to teach in the first place if they knew the money is little. We have sent our inspectors on the ground and are getting results." While the area needs at least 1,280 teachers, we have about 1000; the BDEO says the public **service ceiling requires** them to recruit only 1,040 teachers.

"It is almost impossible to **recruit and retain** teachers. We recruit teachers from out side the district because there are no qualified teachers in the district. When they come here, they find the environment harsh and after a few months, they run away," adds the BDEO. The teachers and pupils have their concern saying lack of meals at school is hindering education. "When I am hungry, I cannot concentrate. i walk over 20 kilometers to and from school, yet when I arrive there is no lunch," says one pupil.

BDEO says they are implementing the education act 2007 that states; every child aged six years and above must be at school. "Through the local chiefs and leaders, we are mobilizing all children to go to school," explains the BDEO. They are also **sensitizing** the parents to support their children with uniforms, food, and **career guidance**. The teachers are supposed to be at school when while police are supposed to implement the rules.

Adapted from The New Vision, May 26, 2010.

Questions;

- a) Suggest a suitable title for the passage. (2 marks)
- b) Explain the causes of pupils' irregular attendance of school as stated by the author. (8 marks)
- c) In not more than 100 words, summarize the reasons for poor performance in Bundibugyo district. (10 marks)
- d) Explain the meanings of the following words and phrases as used in the passage, using your own words wherever possible.
 - i. catch a glimpse
 - ii. almost a decade
 - iii. Deteriorate
 - iv. Abscond
 - v. Compounded
 - vi. Overstretched
 - vii. public service ceiling
 - viii. recruit and retain

- ix. Sensitizing
x. Career guidance (20 marks)
SPGE = 10 marks

6a) Suggest a suitable title for the passage.

- Hurdles of performance
- Craving for performance
- Cry for better performance
- Dream for better performance (2marks)

b) Explain the causes of pupils' irregular attendance of school as stated by the author.

- Others are eliminated because they did not pass the mock examination
- Many have no interest in education
- Pupils' drop out due to marriage (8marks).

c) Reasons for poor performance in Bundibugyo district

- Parents no longer value education due to the war effect.
- Parents prioritized business, luxurious items and early marriage.
- During the Cocoa harvesting season, three quarters of the children do not report to school.
- The district chose 15th and 30th of every month for cocoa harvesting.
- High price of cocoa pushes many to abscond from school
- Teacher absenteeism
- The district sits on a hilly terrain so inspection becomes difficult.
- Poor pay
- It is impossible to recruit and retain teachers.
- Lack of meals is hindering education.

(The summary should be written in one paragraph of continuous English), it should carry a title and one should mind of the word limit. (10 marks) 1 mark for each point

d) Explain the meanings of the following words and phrases as used in the passage.

i) Catch a glimpse; See/look briefly

ii) Almost a decade; for a long period

iii) Deteriorate; Become worse /to grow worse

IV) Abscond; To flee/ to withdraw/to depart secretly/to hide from

v) Compounded; Added on /combined with

vi) Overstretched; Make excessive demands/ to make someone to do more than they can do or should

vii) Public service ceiling; Number of employees who are meant to be employed in a district putting in mind the number of pupils in a school.

viii) Recruit and retain; Appoint and stay with an employee for some time.

ix) Sensitizing; Awareness /make people know/known

x) Career guidance; Advice and information about careers that helps individual especially young people decide on a career and pursue it.

2marks@

SPGE- 10 marks

ACTIVITY 7

6. Read the passage below and answer the questions which follow:

Liberal feminists wish to give women the same rights as men in political, economic and social life, and thus to make human rights work in women's favor; they also favor equality of opportunity. But they would argue that even in liberal societies which promise equal opportunity there is over or *covert discrimination*. Or else institutions and practices are constructed according to male norms in such a way that women are in practice unequal and discriminated against. Sex discrimination occurs where gender is brought into an appointments process or any other allocation process in an *arbitrary* or irrelevant way. Because of sex discrimination legislation, Britain has changed from a society in which, thirty years ago, jobs were strongly gendered to a society where it is illegal for job advertisements to express any preference for male or female employees. Critics of this development would say that it is *rational* and necessary to allocate some jobs on the basis of sexual differences such as physical strength- for example men make better miners. To concede that sex or gender differences are sometimes relevant would lead to the *endorsement* of an equal but in some respects different approach; such a move is strongly criticized by the more radical feminists who claim that the concept of difference itself always relates to a male norm or to the 'normal male' as Mendes argues.

Discrimination in employment is a key issue for liberal feminists since it makes nonsense of equality of opportunity. Despite the existence of sex discrimination laws, the allocation of jobs (or other benefits) according to gender- neutral criteria will not guarantee equality if the nature of the work is already 'gendered', and even gender- neutral criteria may be covertly discriminatory. Suppose an apparently neutral job specification requires that the successful applicant will spend a week every month in America on business and one of the selection criteria is therefore that ' applicants must be free to travel'. Is this indirectly a discriminatory criterion and a gender biased job, because women with family responsibilities could not take on such a work? If so, should such jobs be out- looked because of their inbuilt discrimination, or *radically transformed* by say, job sharing? Similar questions have been asked about parliamentary jobs because MP's *notoriously eccentric* hours of work are incompatible with family obligations.

The argument against discriminatory, gender- biased criteria can be extended to call into question the entire idea of qualifying criteria for any kind of work. In the mid 1970's, I sat on a university working party to monitor possible discrimination in the employment of women academics, who were severely under- represented among the permanent staff at the time. Among other issue, we considered whether the normal expectation that applicants for lectureship should have a PhD was discriminatory. Some people argued that since fewer women (at that time) took higher degrees, because they had married and had children after their first degree, the requirement of a PhD was indirectly discriminatory. It was not a gender- neutral criterion.

Should we then conclude that if women cannot compete on equal terms in a particular arena, we should change the rules of the competition? Liberal feminists would be

reluctant to agree to such a radical conclusion, since they believe in merit as well as in equality of opportunity, an alternative to changing the rules of the competition is to adopt a policy of positive discrimination (which Americans, less pejoratively, call ‘*Affirmative action*’). In the above example, this would require appointment boards to view an intelligent woman without a PhD as no less appointable than an equally intelligent man (or indeed, another woman); it also threatens to **subvert the notion** of appropriate job qualifications. Critics argue that positive discrimination in favor of some is always discrimination against others- also, that it is unjust to appoint a woman on the basis of her membership to a group or category (i.e. because she is a woman) rather than on her personal merit. How then can liberal feminists *cope with the conundrum* those equal opportunities for women in a gendered society may only be achieved through positive discrimination in favor of the less well qualified, which means less than equal opportunities for men? In such a context, implementation of this liberal principle appears self-defeating...

Equal opportunities are not achieved simply by making all jobs equally open to both sexes, because women may be less well qualified, or less free to adapt to the job’s requirements because of family ties. Moreover, some feminists argue, work is a male defined activity, defined so as to make women appear unsuitable for work. Radcliffe Richard puts the case: “if women had been fully involved in the running of society from the starts, they would have found a way of arranging work and children to fit each other... the modest, *reformist demand* for liberal equality logically takes liberal feminists beyond equal employment legislation and commits them to advocating either a radical restructuring of work to fit in with family life or a radical restructuring of family life, motherhood and childhood.

Questions

- a) Suggest a suitable title for the above passage.
- b) What does the author mean by?
 - i. “... Jobs were strongly gendered?”
 - ii. “In such a context, implementation of this liberal principle appears self-defeating...”
- c) In about 100 words, describe the views of the liberal feminists on gender equal opportunities in society.
- d) Explain the meaning of the following words and phrases in the passage, using your own words as much as possible:
 - i. Covert discrimination (02 Marks)
 - ii. Arbitrary (02 Marks)
 - iii. Rational (02 Marks)

iv. Endorsement	(02 Marks)
v. Radically transformed	(02 Marks)
vi. Notoriously eccentric	(02 Marks)
vii. Affirmative action	(02 Marks)
viii. Subvert the notion	(02 Marks)
ix. Cope with the conundrum	(02 Marks)
x. Reformist demand	(02 Marks)
Spelling and Grammatical Expressions (SPGE) =	(10 Marks)

ACTIVITY 8

GENERAL PAPER S101/1
2 HOURS 40 MINUTES

INSTRUCTIONS TO CANDIDATES:

- (i) A total of 2 hours and 40 minutes includes 10 minutes for you to study the questions before you begin your answers.
- (ii) Answer **two** questions in all, choosing **one** from Section **A** and **one** from Section **B**.
- (iii) Answers to each question must begin on a fresh answer booklet and should be handed in separately.
- (iv) Explain your points with relevant examples please.

SECTION A.

1. Discuss the importance of a national language to your country and show how the obstacles to the formation of a national language should be overcome.
2. The recent discovery of oil reserves in Uganda is a curse to the country. Comment.
3. Examine the causes and consequence of the increasing murder cases in Uganda today.
4. To what extent have scientists helped Uganda to achieve economic development?

SECTION B

5. Study the information provided below and answer the questions that follow.

In a village called Nyamihuuka, there are five young women and men eligible for marriage. Controversy has risen due to a failure by these youths to choose partners from amongst themselves. A council of elders has been convened to resolve this matter using the following criteria.

- All the eligible men and women must be married off.
- Any youth eligible for marriage is free to join the group at any stage in search of a partner. This may lead to the displacement of an individual in the group.
- The outcome of the criteria laid down by the elders is considered final.
- The young man with the best attributes is paired with the young woman ranked highest on the list. This order of merit is followed until the attributes agreed upon by the elders for the young men and the corresponding weights are shown below:

Attributes	Weight
Willingness to pay bride price	4
Bravery	1
HIV/AIDS test (negative)	6
Wealth	3
Education (minimum 'O' Level)	5
Physical appearance	2

- Zepha is an ugly wealthy businessman but he is a miser and illiterate. He has vowed to fight bride price. He is HIV positive.
- Xavier is a very handsome university graduate, but he is coward and lazy. He is yet to take the HIV/AIDS test.
- Vincent has a farm with fifteen Friesian cows. He has attained an 'O' level certificate. He lost one eye while fighting off a lion that had attacked his cows. He is HIV negative.
- Willy has twenty-five cows of the local breed. He is illiterate but handsome, hardworking and a good hunter. He has refused to take HIV/AIDS test.
- Y oash comes from a wealthy family and has completed senior six. He is HIV/AIDS negative.

All the young men unless otherwise stated, are willing to pay bride price if it is affordable. The young women have been ranked by the elders in a descending order of merit as follows:

- Brenda
- Esther
- Cathy
- Allen
- Diana

Questions:

- a) Following the elders' criteria, determine which young man will marry: which young lady in the village,
- b) If a sixth young man, Quinto, shows up with the following attributes: handsome, newly qualified teacher and HIV negative, how would he affect the pairing in the group?
- c) Why should HIV/AIDS testing be a priority during marriage arrangements?
- d) Examine the relevance of bride price in your community.

6. Read the passage below and answer the questions which follow using your own words wherever possible.

Until quite recently domestic violence had been an open secret in our society, as in many others. Gradually we have come to understand that families can live in a state of fear for years, while one member, not always the husband and father, becomes more and more emotionally and physically abusive. Often, it is not until someone sustains particularly shocking injuries, or dies, that the truth about abuse becomes known.

The abusers can be fathers or mothers, brothers or sisters; the victims may be young or old. The circumstances that allow violence to develop in a family and become part of its structure are only partly understood.

In many cases, the power and freedom once given exclusively to men is a big part of the problem. In other cases, the poor emotional development suffered by many men can be a factor.

The poverty that can come with unemployment can cause problems, particularly for men. Often violence is an outlet for their feelings of isolation, powerlessness, and inadequacy. Women and children can pay an especially high price for his violence born of frustration.

Some people never have the opportunity to observe closely a family that works well. To other people, this is the most natural thing in the world; but to some, it's a mystery. Some people may grow up in a family with emotional or money worries; when they start their own family, they may well duplicate the problems of their first family. Women who have babies they don't want or are not ready for and men who think they'd better settle down can find that the romantic fantasies on television and in the movies have little to do with real life. These women and men can become tyrants or victims in their own domestic hells; when children are involved it can seem that there is no way out.

A researcher in criminology at the University of Melbourne, Ms. Ruth Frances, says her researcher showed that 67 per cent of men who committed domestic violence had seen it in their own parents, and 63 per cent had been abused as children.

A sign of hope, however, could be seen in the number of men under 39 who, she says, 'are more likely to turn up at Community Health Centers and say, "I'm being violent and I need help to stop it". This assumes, however, that they have a properly resourced Community Health Centre to go to. How much money is being saved 'rationalizing Community Health Services'? The cost may well be spent many times over in police, hospital, refuge, legal and prison services.

Do men know what they're getting into when they start a relationship, and when they have children? What if their childhood family was a place of fear and violence/how do they learn how to act? What if it costs money to resource such family education? Are you prepared to pay?

Perhaps part of the solution for more successful families is to teach children what it takes to live successfully within a family – give them the chance to experience as much positive interaction as they can both inside and outside their own families.

Play grounds for young children and guided activity groups for adolescents seem an obvious idea for establishing good habits of cooperation and undertaking.

People often ask why women stay in abusive relationships. Why would a woman stay in a situation where she was regularly hurt; where the attacks become worse? The answers are not straight forward. Money may be one explanation. If the husband is working, he provides money for his partner and children to buy basic necessities. She may have few employable skills, and may lack confidence and experience of work.

Some women believe they need a man to make their lives complete; that they are worthless without one, and that this is more important even than life itself.

Some courts have recently begun to accept the existence of a syndrome where women, often married to their tormentors, may accept year after year of physical abuse, mental cruelty and rape from the men they live with. One day, without warning the women may erupt out of her passive state and kill the man. The courts are left to decide a just response.

Repeated acts of violence, altering very often with phases of kindness and loving behavior; commonly leave the battered woman in a psychological condition described as 'learned helplessness'. She cannot predict the occurrence of acute outbreaks of violence. This often reinforced by financial dependence, children and feelings of guilt.

Questions:

- a) Suggest a suitable title for this passage.
- b) (i) Why according to the passage is it very necessary to have Community Health Care Services to deal with the problem of those violent in their homes (use one sentence).

(ii) What is meant by "cannot predict the occurrence of acute outbreaks of violence".

- c) In not more than 120 words summarise the causes of abuse in homes and why women stay in abusive relationships.
- d) Explain the meaning of the following words and phrases as used in the passage.
- i) Open secret
 - ii) Shocking injuries
 - iii) Partly understood
 - iv) Mystery
 - v) Duplicate
 - vi) Romantic fantasies
 - vii) Domestic hells
 - viii) Positive interaction
 - ix) Syndrome
 - x) Learned helplessness.

ACTIVITY 9

S101/1 GENERAL PAPER

2 HRS 40 MINS

INSTRUCTIONS:

- The total time of 2 hours and 40 minutes includes ten minutes for you to study the questions before you begin your answers.
- Answer two questions which must be chosen as follows: One question from Section A and one question from Section B.
- Answers to each question must begin in a fresh answer booklet which should then be fastened together.
- You are advised to divide your time equally between the two questions.
- All questions carry equal marks.
- Any additional question(s) answered will not be marked.

SECTION A

Answer one question from this section.

Answers should be between 500 and 800 words in length.

1. Discuss the causes and effects of land wrangles in your country.
2. To what extent is juvenile delinquency in your country attributed to parental negligence?
3. Explain the causes of teenage pregnancies in your community and suggest possible solutions.
4. Assess the challenges women face in the development of your country.

SECTION B

Answer one question from this section.

5. Study the information below and answer the question.\

STRIDE HIGH SCHOOL WAKISO is one school that recorded many cases of crime in the year 2016. This situation was mostly reported in the five boys' dormitories. These included Elgon, Muhavura, Everest, Kilimanjaro and Rwenzori. The situation was so bad that the students threatened to stage a strike if the administration did not intervene. In response to this the school administration was prompted to formulate a committee to investigate the matter and later find solutions to the problem. The investigations were held basing on the following allegations.

Elgon harbored smokers, thieves and boys who took alcohol.

Rwenzori: had lost some of its furniture due to fights and also had obscene speaking boys who liked drinking Waragi.

Muhavura had cases of theft. Some of the boys not only sneaked out of the school to take alcohol but also slept with village girls and used obscene language.

Everest had a few cases of theft

Kilimanjaro had cases of smoking, use of obscene tongue and frequent fights. After thorough investigations the committee confirmed the following:

Elgon had cases of theft and alcoholism.

These were boys in Rwenzori dormitory who had injuries from previous fights while others had drinking problems, smoked and also used obscene language.

Muhavura had cases of boys who had once been caught sleeping with village girls in the dormitory toilets. Some smoked and hurled insults at the wardens.

Everest had theft, cases of fights and a few boys who took alcohol.

Kilimanjaro had some boys who had once sneaked into the girls' dormitories to meet their girl friends.

Questions:

- e) Draw a table showing the findings of the committee. (10 mks)
- f) Give the dormitories that were
 - iii) Most affected by indiscipline cases. (01 mk)
 - iv) Least affected by indiscipline cases. (01 mks)
- g) Suggest how schools should effectively handle indiscipline cases by students. (13 mks)
- h) How should students avoid getting themselves involved in crime while at school? (15 mks)

6. Read the passage below and answer the questions that follow, using your own words wherever possible.

There is another feature of present-day society which has played a part in the development of a counseling profession. It is instability generated by the rapid changes that have been occurring in our ways of life. Sociologists as well as poets have labeled this an 'age individual, factors ranging all the way from broken homes to the threat of atomic annihilation. It is true that it would be very difficult to prove that this age is more anxious than previous periods. There are no statistics which permit us to compare the incidence of even more impossible to gauge the comparative frequencies of neuroses and the lesser varieties of disequilibrium. Nevertheless, in the books we write and the pictures we paint there is much to suggest that the prevailing mood of our time is one of uncertainty and apprehension.

The most serious of the social instabilities for the individual, if the conclusions of psychiatrists and other mental health workers are sound, is the threat to the family. Among the clients who come to a counselor with personal problems, a very considerable proportion are children of divorced parents. Sometime during their childhood, long before emotional growth was completed, they have been confronted with problems of conflicting loyalties that would have strained even the capacities of maturity. The counseling process constitutes for them a new opportunity to think the whole thing through and assimilate the experience and its consequences in their later development.

If divorce itself were the only problem, however, our task would be considerably easier than it is. It is the emotional conflicts that lie at the back of these break-ups rather than the separations themselves which unsettle children. Naturally, not all persons seeking psychotherapy are the products of divorce, but most if not all of them reflect in their attitudes the strains to which their children homes were subject. For every marriage that ends in the divorce courts there are probably several more which generate tensions almost as severe. Children in these homes have had to learn to cope with bitterness, hatred, neglect and confusion and to put up some sort of defenses against the anxiety such attitudes bring.

It goes without saying that social problems are not to be solved by counseling alone. Many agencies and organizations are concerned with the family and are attempting to improve on unsatisfactory situation there. To the extent that long-range educational programmes aimed at improving family relations succeed, counseling to ameliorate the effects of bad family situations will become less necessary. For the present, however, home difficulties are a major source of problems for workers in three type of setting. Child guidance clinics are attempting to help the children themselves at the time when their problems are most acute. Marriage counselors have developed a specialized service for men and women who wish to try to salvage their relationship rather than to break it off. General counseling agencies in schools, even when their principal function is to help students make good educational and vocational choices, also help individuals to understand and modify emotional attitudes that have grown out of home environments.

Many other social problems of our time are reflected in the insecurities clients bring to counselors. The rapidity with which urbanization has proceeded has brought into the

incredibly complex city environment large numbers of individuals whose upbringing has not prepared them to cope with it. Threats of war, and actual wars in which our country is involved... not only add to the complexity of the task of career planning, but also face young men and women with difficult choices among conflicting values. The constant threat of unemployment arising from technological changes hangs over men and women most of whom have no control over their own jobs. The emphasis a competitive society places on success inevitably produces anxiety in persons who cannot be sure that they are 'winners'.

While the counselor, as a citizen, may be vitally concerned with these social problems in their entirety, it is particular aspects of them, often not the most important that confront him in his day to day work. The possibility of sudden death and destruction does not seem to produce as much anxiety as do the minor worries about one's own immediate future. Will I be drafted this year or not? Shall I enlist now or wait? What good will it do me to study this term if I am not going to be allowed to finish my education anyway? It is through such questions that the trouble international situation makes its impact on the individual: will I ever be able to get my grades up high enough so that I will be admitted to medical school? How can we keep up our country club membership and the social activities that go with it unless I can make up our country club membership and the social activities that go with it unless I can make more money? How can I ever face mother if her sorority doesn't pledge me? How can I get over my inferiority complex? Wherever I go I never feel good as other people. It is such problems that our competitive economic and social system raises for each person. They may seem trivial by comparison with the larger social issues, but they are the stuff individual human experience.

Questions:

- a) Suggest an appropriate title for the passage.
- b) Explain what the author means by:
 - i) 'conflicting loyalties'.
 - ii) 'but they are the stuff of individual human experience'.
- c) In not more than 100 words, give a summary of the problems a counselor has to deal with.
- d) Explain the meanings of the following words and phrases as used in the passage using your own words wherever possible.
 - i) annihilation
 - ii) gauge the comparative frequencies
 - iii) of uncertainty and apprehension
 - iv) assimilate
 - v) lie at the back of
 - vi) ameliorate
 - vii) salvage
 - viii) principal function
 - ix) technological changes
inferiority complex

ACTIVITY 10

GENERAL PAPER

2HOURS 40 MINUTES

INSTRUCTIONS:

- Answer two questions which must be chosen as follows. One question from Section A and one question from Section B.
- Each section should be written on its own answer sheet.
- All questions carry equal marks.

SECTION A

Choose one question from this section.

1. Assess the impact of mobile phones on the Ugandan society.
2. To what extent have human rights been observed in Uganda?
3. "Uganda would be better off without foreign aid." Discuss.
4. Account for the moral degeneration of the youth in your society.

SECTION B

Answer one question from this section

5. Study the following information carefully and answer the questions which follow:

PART I

A second year student of Diploma in computer science has a course schedule running from September through June. In this period, he must take a course in Windows, four courses in Word Perfect, Lotus 1 and 2, and Financial Accounting 1, 2 and 3.

There are some guiding regulations:

- i) Each course is one month long and must always be taken alone.
- ii) Windows can only be taken after Lotus 1 has been taken.
- iii) Lotus 2 can only be taken after Windows has been taken.
- iv) Financial Accounting courses cannot be taken in consecutive months.
- v) Word Perfect 1 and 2 must be taken in consecutive months.
- vi) Word Perfect 3 and 4 must be taken in consecutive months.

Questions:

- (a) In which pairs of months can the student take the two Lotus courses?
- (b) If the student takes Word Perfect courses in September and June, in which months, other than September and June, will it be impossible to take a Lotus course?

(c) Make a schedule in which the student takes the two Lotus courses, one Word Perfect course, and one Financial Accounting course from September to January.

(d) When does a student who wishes to complete both Lotus courses before taking any Financial Accounting course take Word Perfect?

PART II

The American units of money are the dollar and the cent and one dollar = 100 cents. The symbol for the dollar is \$. Therefore \$24.60 means 24 dollars and 60 cents. The rate of exchange to the pound (the symbol for the pound is £) is £2.40 which means that for every £ 1 changed into dollars, you receive 2 dollars and 40 cents.

The French unit of money is the Franc and Centre. 1 Franc = 100 Centre. The rate of exchange is 1375 Francs for £1.

Recently the French introduced a heavy Franc which is equal to 100 of the old Francs. The Uganda unit of money is the shilling. The exchange rate is 1680 shillings for £1.

Questions:

- (a) How many shillings are needed for;
 - (i) One old Franc?
 - (ii) One new Franc (the heavy Franc)?
 - (iii) The dollar (\$)?
- (b) How many Heavy Francs are there in?
 - (i) One pound (£1)?
 - (ii) One dollar (\$)

6. Read the passage below and answer the questions that follow using your own words wherever possible.

Education is both a fundamental right and an essential means of enjoying other human rights. It allows economically, social and culturally marginalized people and groups to break out of the cycle of poverty and exclusion, to play a useful role in society, and to develop a sense of their own dignity.

A number of international instruments focus specifically on the objectives that education should be aiming at, despite the fact they limit themselves to formulating or re-stating general principle instead of identifying a precise content of education. Of course, the weakness of **international legislation** is explained, as it is in any branch of the law, by their relative newness, and by the fact that attention has been focused on them only recently. However, it is worth noting that unlike certain features involved in attaining the right to education (e.g. actually putting an education system in place), non-discrimination cannot be achieved '**progressively**' but needs to be immediately and fully guaranteed, and apply uniformly to all states, whatever their level of development.

The numerous factors that have a negative influence on education in respect to racial discrimination and racial intolerance include the historical circumstances, the social and economic conditions of groups and minorities, their cultural deprivation, the prejudices of dominant groups, the status of minority and majority languages, the political will of the government and of the groups themselves, the inadequacy of the resources, and the absence of intercultural dialogue.

It is not realistic to act on these factors, and imagine that this will immediately have the anticipated result. In fact, some of these factors have nothing to do with education, and require a major input and vast resources on the part of the state and the international community. Meanwhile, others do not call for large resources, but instead need long term action because they touch on matters that by definition evolves slowly and not always along a linear path.

Responsibility for the education process falls on the whole of society, and not the state. Several players, including the family, the media, civil society, religious groups, the private sector and NGO's help to shape children's mind. Combating racism and intolerance in a school environment is also a matter of conviction and representatives of various religious sects need to be brought together at national and international level. The state has a major responsibility for overseeing the whole of the public and private education system so that it can detect *de facto* and *de jure* acts of racial discrimination and manifestation of religious intolerance and ban them and possibly suppress them. States need to adopt precise measures and ensure that they are being implemented effectively, especially with regard to the minimum age for commencing employment, so as to protect vulnerable groups, particularly of an ethnic and religious nature, from dropping out of school early.

Whatever may be said in their favour, separate education systems are not in a position to promote the integration of minorities and immigrant communities although in some scenarios they are able to protect the rights of ethnic and religious minorities. The state has obligations with regard to recognizing qualifications issued by these schools, and for a range of services (e.g. financial help with teacher training, the upkeep of buildings, and awarding subsidies and grants to students) which, when no offer should be provided on a non-discriminatory basis.

Without exception, and irrespective of what they are called (e.g. separate schools, separate classes or minority schools), separate systems of education must not be administered in a way that they impede these groups from understanding the majority group, particularly its language, culture and religious beliefs.

Reforms, no matter how well conceived, will fail if teaching staff are not well trained or sufficiently committed to combating discrimination. To put it in another way, the role of the teacher cannot be reduced to that of a technician tasked with carrying out laid down procedures, but of a professional able to determine the most appropriate and effective pedagogical approach in a given situation. In particular, it is the duty of teaching staff to help to alleviate tensions between pupils, ensure that school curricula take account of the diversity of group, and promote a plural and tolerant form of education and a non-discrimination culture.

The recruitment of teachers must take account of the specific needs of plural societies and reflect their ethnic variety. Moreover, intercultural education and the fight against xenophobia, racial prejudices and intolerance need to be incorporated into initial and follow-up teacher training courses.

Education must develop a positive representative of oneself and others. Changing the content of text books. (e.g. History, Geography, Language, Literature, General culture, and

Civic and Religious education, Stories of children and Strip cartoons) must impact on all education curricula whose content is likely to shape the minds of children and adolescents and their future representation of others. Any historical facts (or simply observations), tendentious explanations and insinuations that might **exacerbate tensions** or create a negative representation of others, must be withdrawn, and replaced with fresh teaching materials that stress the unity of humankind and the amazing range of its human components and encourage respects between different ethnic religious and linguistic groups.

Multicultural (or pluricultural) schools that are premised on taking account of racial and/religious diversity and on drawing up specially adapted curricular are not enough in themselves if we want to deliver and an education in tolerance. If we do not want to devalue or over value different cultures, **and thereby avoid a sense of hegemony**, fear and intolerance, we need to gradually introduce a form of intercultural education based on a comparative perception of the various cultures, while at the same time taking account of specific local features.

Inter-cultural education cannot be imposed by administrative fiat. The path to tolerance and a positive understanding of others will be long and hazardous. Teachers have a key educational role, and they must have the tact needed to encourage students to have a spirit of inquiry and avoid the sometimes inconclusive outcomes of intercultural education. It would be wrong to expect pupils to respond in a uniformly positive way to the effects of intercultural schooling. Objective factors which as the influence of tradition, history and religion, and social cohesion play a role; they also have a major influence on whether the implementation of this policy succeeds or fails.

The issue of human rights must have a place in education curricula. What it comes down to though is how human rights can be better taught. The pedagogical dimension of this area of education is decisive in relation to the quality of the message received by pupils and students. First and foremost, as the committee of the Elimination of Racial Discrimination human rights and issues of racial discrimination, must be taught in a multidisciplinary way so that racism cannot claim a scientific basis.

Standards should be set with a view to adopting interpretative rules that make it easier for states to understand exactly what strategy they need to adopt with **regard to non-discriminatory, tolerant education**. In particular, this work should focus on the development of education curricular and course books in history and other sensitive subjects, the teaching of which is likely to shape pupils' minds in respects of their perceptions of cultures and civilizations that are different from their own UNESCO has a key role to play in urging states to adopt appropriate measures in order to examine, and possibly amend, legislation that might be discriminatory in the field of education because of religious beliefs or language.

There is also a need to strengthen control mechanisms through agreements and instruments. Education is the fundamental human right that is necessary for other rights to be fully exercised. It therefore seems entirely logical to draw out all the legal implications of this in relation to the existence of appropriate appeal mechanism and the effective protection of this right.

Questions:

- (a) Suggest a suitable title for this passage.
- (b) In your own words explain what you understand by the author's definition of education.
- (c) In not more than 100 words, show how society and the state can help shape the education system.
- (d) Explain the meaning of the following words and phrases as they are used in the passage;
 - (i) Marginalized people and groups,
 - (ii) International legislation,
 - (iii) "Progressively"
 - (iv) Prejudices of dominant groups,
 - (v) A linear path,
 - (vi) Vulnerable groups,
 - (vii) Exacerbate,
 - (viii) A sense of hegemony,
 - (ix) Hazardous,
 - (x) Civil society

ACTIVITY 11

GENERAL PAPER S101

TIME: 2 HOURS 40 MINUTES

INSTRUCTIONS:

- The total time of 2 hours and 40 minutes includes 10 minutes for you to study the questions before you begin your answers.
- Answer **two** (2) questions which must be chosen as follows: one question from Section **A** and one question from Section **B**.
- Answers to each question must begin in a fresh answer booklet and should be handed in separately.
- You are advised to divide your time equally between the two questions.
- All questions carry equal marks.

SECTION A

Choose **one** question and write an essay of between **500** and **800** words.

1. Explain the causes of military coups in Africa. Suggest measures to deal with this problem.

2. Discuss the causes and effects of human trafficking in your country.
3. Assess the importance of wetlands in Uganda and suggest measures which should be taken to protect wetlands.
4. To what extent has the television promoted crime among the youth in your community?

SECTION B

5. Read the information below and answer the questions that follow.

A group of seven people belonging to an organization called “Brain Trust” had a debate on the motion: “**Production of Cigarettes should continue**”.

Members were: Boa, Rudi, Kameo, Loka, Tim, Waako and Tema.

The following conditions were to be fulfilled:

- All participants to sit in a single line.
- The Chairman takes the middle seat.
- Proposers and opposers take opposite sides from the Chairman.
- First speakers must be seated next to the Chairman.

The following prevailed during the debate:

- Tim was the first speaker. He spoke about the advantages of smoking.
- Tim and Tema had conflicting ideas.
- Tema was seated to the left hand side of Waako.
- Boa was seated between Tema and Loka.
- Rudi was seated between Tim and Kameo.

Questions:

- (i) Draw a simple table to show the sitting arrangement.
 - (ii) Who was the Chairman of the debate?
 - (iii) Who is likely to have discussed the disadvantages of smoking?
 - (iv) List the names of the proposers starting with the one seated next to the Chairman.
 - (v) List all the names of opposers starting with the one seated furthest from the Chairman.
 - (vi) Do you think Boa and Loka had conflicting ideas? Give a reason for your answer.
 - (vii) Write **TRUE** or **FALSE**:
 - (a) Loka was the last speaker.
 - (b) Kameo and Boa had conflicting ideas.
 - (c) Tim and Rudi had similar lines of argument.
 - (d) Boa disagreed with Tim.
 - (e) Boa was the first speaker to propose.
 - (f) Because the debate had equal number of participants on each side, it ended in a draw.
6. **Read the passage below and answer the questions that follow.**

As is usual in any romantic theory, we find the name of Byron conspicuous. The Byronic hero in his successive metamorphoses has filled- and also written- more books than the tongue can tell. He is volcanic, extreme in all things, magnificent in sin. He is adored of woman (or, conversely he is misunderstood and betrayed by women and retires into lofty isolation and the pageant of his bleeding heart). With the help of modern psychology, he has developed complexes and neuroses. At times, to be sure, he evinces a spasmodic and spectacular goodness, but this is a manifestation of his superb energy and must never, according to the theory, be confused with the goodness of good people.

Early in the nineteenth Century, this theory got tangled up with Napoleon and also with far-reaching consequences, with German philosophy. Students of the history of philosophy point to the doctrines of Fichte. From this source come the Superman, the Master Race, Prussianism, and Hitler. Until there was an actual outbreak in war, we did not resent this kind of thing because the ideas were not very different from ones that we had been brought up on. Not many of us were fooled by Hitler as a person. A bad egg if ever there was one. Yet there was something comic about him, we are such a good-natured people that we find it hard to realize that funny things can be dangerous.

Furthermore, we saw that Hitler and his friends had energy, and we rather admired them for it. We didn't blame them for not wanting to be bullied. We were inclined to discount the stories of domestic terrorism. Even after the war began in Europe, we felt a certain respect for Prussian competence and efficiency. We were genuinely confused by the romantic theory of evil. The thing that awoke us up was not the badness of the egg but the terrific consequences of the things that particular egg did. When the war is over, unless I miss my guess, we are likely to be again misled into the same confusion of values.

There is still a third modern theory of evil, and this I shall call the scientific theory. According to this, there is no such thing as sin. Human beings are merely very complicated mechanisms, and they are what they are because of the regular operation of heredity and environment, economic law, vitamin deficiency, hypertrophy of the glands, or whatever else you happen to believe in. Hitler is a paranoiac, and the whole German nation is suffering from a secondary, or induced, paranoia. Exponents of this theory remind us that science doesn't judge; it only explains. You can't blame Hitler for being a paranoiac any more than you blame poison ivy for being poisonous. Some day science will tell us what to do about it, but what if that day doesn't come soon enough?

Here are three ways of looking at the evil in human nature – the sentimental, the romantic, and the scientific. Each one of them has qualities that commend it to the American temperament. Our good heartedness makes us like the first; our energy and independence incline us to the second; everything that is scientific in our education and training prepares us for the third. The fact that they are often contradictory doesn't worry us. Whatever our characteristic American virtues are, logic isn't one of them. We share with the other English-speaking peoples a genius for living happily with contradictions, anomalies, and compromises. And where does it all get us?

Let me return momentarily to Milton. Far be it from me to say that he knew all the answers, but he knew some of them. He knew that ambition leads to cruelty and terror, he knew that the human race can be saved only by goodness, the goodness of God in man. He knew that the forces of Hell are real and are everywhere and always. He saw them in his imagination, surging and seething and boiling up onto this earth. Theologies, to be sure, are transitory, far more transitory than poetry. So far as *Paradise Lost* is purely theological, it may be obsolete, but as an analysis of good and evil, it teaches a lesson that we still need to learn. Over the theology of the poem towers Satan, incarnate evil, the arch fiend, the destroyer, and on his head sits horror plumed.

I should like to finish this with a noble peroration on the splendours of American goodness, secure in its native right and triumphant over evil in all its forms, but I shall be on much safer ground if I merely sum up what I have said already. Taking us by and large, we have a considerable faith in goodness and good people. That faith is probably greater than we realize, and in this respect we are lucky, because a faith in the goodness of men is the one thing that democracy cannot do without. Beyond that we are entangled in a lot of familiar notions about good and evil, accepting now one and now another, never following any of them to their logical conclusions. We can get through this war, I am sure, on our faith in ourselves and our native goodness. It is after the war that we are going to run into trouble. Shall we look at Germany as a nation of beautiful souls, temporarily misled in their emotions but presently to return to an idyllic existence of Beethoven, beer, and Grimm's fairy tales? Or as a Byronic hero-nation, magnificent in sin, romantic in its defiant energy, and then tragic in its defeat? Or as the victim of an unfortunate environment, needing merely a treatment in international economic therapy?

Or shall we really get down to the roots of good and evil and wrestle with our theories until we bring them into some kind of working conformity, not only with one another but with fact?

Questions:

- (a) Suggest a suitable title for this passage. (02 mks)
- (b) What does the author mean by?
 - (i) "funny things can be dangerous"? (03 mks)
 - (ii) "living happily with contradictions"? (03 mks)
- (c) In not more than 100 words, summarise the theories of the evil in human nature. (12 mks)
- (d) Explain the meaning of the following words and phrases as used in the passage, using your own words wherever possible.
 - (i) Conspicuous
 - (ii) Lofty isolation
 - (iii) Domestic terrorism
 - (iv) Complicated mechanisms
 - (v) Temperament
 - (vi) Obsolete
 - (vii) Familiar notions

- (viii) Defiant energy
- (ix) Economic therapy
- (x) Working conformity

(20 mks)

Spelling and Grammatical Expressions (SPGE)

(10 mks)

END

ACTIVITY 12

S101 GENERAL PAPER

INSTRUCTIONS TO CANDIDATES:

The total time of **2 hours** and **40 minutes** includes **ten** minutes for you to study the questions before you begin your answers.

Answer **two** questions, which **must** be chosen as follows: **one** question from section **A** and **one** question from section **B**.

Answers to each question **must** begin in a fresh answer booklet, which should then be fastened together.

You are advised to divide your time equally between the **two** questions

All questions carry **equal** marks

Any additional question (s) attempted will **not** be marked.

SECTION A

Answer **one** question from this section.

Answers should be between 500 and 800 words in length.

1. Account for the persistent increase in the level of unemployment in Uganda. (50 marks)
2. “Microfinance institutions are more exploitative than redeeming to Ugandan entrepreneurs.” Discuss. (50 marks)
3. Examine the causes and effects of prevalent high levels of corruption on the Ugandan society. (50 marks)
4. To what extent is the government responsible for the land disputes in Uganda? (50 marks)
5. Four countries namely; Uganda, Angola, Senegal and Liberia were in the same group G for World cup qualifiers.
Each team had to visit each of the teams in the group on home and away basis.

Points were awarded as shown below.

Result	Points
Any win	3
Any draw	1
Any	0

It was further observed that

- (i) Each team won at least a game.
- (ii) Uganda won all of its games except a 1 – 1 draw with Senegal and 0 – 2 defeat from Angola.
- (iii) Angola drew only once with a 0 – 0 against Senegal and only won once while from away.
- (iv) Liberia got no point from away.
- (v) In history Senegal can either win or loose while at home.
- (vi) The game for Liberia V's Senegal ended 0 – 2.

Questions

- (a) Find the number of points for each team. (16 marks)
- (b) Account for the low levels of sports activities in Uganda. (08 marks)
- (c) In what ways has sports betting affected the lives of the youth in your society. (08 marks)
- (d) Examine the role played by the sports sector in the development of an economy. (08 marks)

Spellings and grammatical expressions (SPGE) (10 marks)

6. Read the passage below and answer the questions following it with your own words wherever possible.

Since the end of the cold war, a major concern has been the problems caused when

stated falling that is, when governments fall apart or become incapable of maintaining peace within their own boarders. In recent years, international peace keeping troops have been dispatched to Somalia and Haiti to help restore order in these countries and the world has witnessed mass killings in Rwanda and random violence on the streets of Monrovia, the capital city of Liberia.

Each of these civil conflicts has produced streams of refugees into neighbouring countries.

What were the roots of these conflicts, and why are so many occurring today? No single cause or theory can fully explain why societies fall into disorder, and it is unrealistic to expect human behaviour to follow predictable laws as physical systems do.

A group of researcher led by university of Toronto political scientist Thomas Hommer-Dixon hypothesizes that one frequent characteristic of societies vulnerable to internal conflicts is scarcities of such critical natural resources as fresh water, farmland, forests and fisheries. As people compete for access to these resources, some gain more than their share, while others become increasingly marginalized.

Misunderstanding the complex interplay of factors involved in such conflicts, those affected may blame historic or traditional enemies in other ethnic groups. Governments face escalating demands to mediate the resulting tensions.

Decisive action may be hampered by a shrinking tax base, perhaps because the dominant (usually wealthier) factions have influenced tax policy to their own benefit. At some point, the pressure on the weak and resource-poor governments becomes too much and they collapse.

Homer – Dixon and his colleagues contend that the growth of population contributes to the under-lying environmental scarcities in at least three important ways: through subdivision and depletion and degradation of the resource base. As greater numbers of people divide a fixed quantity of fresh water or crop land, for example, the amount available to each person shrinks.

To the extent the resource is renewable, its total size may remain the same, but less is still available to each person.

To the extent the resource is not renewable and even water and land can become non-renewable resources when they are used beyond critical thresholds of renew ability the same process can cause resource depletion or degradation. In any combination of the three impacts, natural resources become less available as the number of people needing them increases.

The same set of impacts can result as well from increases in per capital consumption by a stable population. Most frequently population and consumption patterns interact to increase the use of natural resources more rapidly together than either would force by itself. Especially in the presence of other key ingredients in history of ethnic strife, inequitable divisions of power and wealth, an ongoing economic crisis, for example this process can set the stage for acute conflict.

This explanation may fit most closely the circumstances of many developing countries, which are more likely than wealthier countries to feel the impacts of environmental scarcity and less able to compensate for resource scarcities through trade or substitution. Elements of the theory, however, may apply to wealthier countries as well.

Population growth increases the demands for the kinds of services that all governments must provide.

The more rapid the growth in numbers of people in demand, the need to expand basic infrastructures like roads, water supply,, hospitals and schools, for example become especially acute. When the number of dependent children is high relative to that of the working adults, these demands can become excessive in relation to the revenues governments derive from taxes.

The crowding that accompanies population growth inevitably multiplies the rate of basic human interaction. To maintain order societies, require some degree of regulation or other forms of mediation in the words of Fred Charkas Ukle.

More often than not, higher densities will lead to more government. More crowding means more people will bump into one another; people nowadays demand that the government interfere even more of an unintended consequence of (population) growth will be more government.

Where governments are neither resourceful nor effective, however, the tendency may be not toward bigger government but simply towards governmental breakdown.

By Thomas Homer. Dixon.

American Association for the Advancement of Science

Questions

- (a) Suggest an appropriate title for the passage.
- (b) (i) How does the author view resource distribution in society?
(ii) What does Fred Charles Ikle mean by more government?
- (c) In not more than 100 words, summarise how population growth affects developing countries.
- (d) Explain the meaning of the following words and phrases as used in the passage.
 - (i) Predictable laws
 - (ii) Complex interplay
 - (iii) Critical thresholds
 - (iv) Key ingredients
 - (v) Hypothesis's
 - (vi) Underlying
 - (vii) Stable population
 - (viii) Acute conflict
 - (ix) Inevitable
 - (x) Mitigate

END

ACTIVITY 13

GENERAL PAPER

INSTRUCTIONS TO CANDIDATES:

The total time of 2 hours and 40 minutes includes ten minutes for you to study the questions before you begin your answers.

Answer two questions, which must be chosen as follows: one question from section A and one question from section B.

Answers to each question must begin in a fresh answer booklet, which should then be fastened together.

You are advised to divide your time equally between the two questions.

All questions carry equal marks.

Any additional question (s) attempted will not be marked.

SECTION A

Answer one question from this section.

Answers should be between 500 and 800 words in length.

7. What is the role played by performing artists in the development of your community? (50 marks)
8. Assess the role of traditional healers in Uganda today. (50 marks)
9. Account for the occurrence of terrorism attacks on African countries today.

What steps can be taken to reduce on the rate of these attacks? (50 marks)

10. Is mob justice the right way of punishing criminals? (50 marks)

SECTION B

Answer **one** question from this section.

11. Mr. Okombo is the class teacher of senior six in a certain government school. A science class at the advanced level consists of only four students and the available subjects are Physics, Chemistry, Biology and Mathematics.

These four science subjects are done by all the four students. Teachers handed in students' marks without indicating the names of students as shown below in percentages:

Physics:	60, 53, 28 and 33
Biology:	36, 38, 67 and 52
Mathematics:	52, 30, 18 and 48
Chemistry:	18, 38, 46 and 20

These results were for the four students; Annet, Cissy, Evelyn and Bonny. The class teacher called all the subject teachers and realized the following:

- (i) A student is considered to have passed a science subject if scored 30% and above.
- (ii) Annet's marks were ending with a common number in all of the four subjects but had two science subjects with equal marks.
- (iii) All students who failed Mathematics also failed Physics.
- (iv) A mark divisible by 11 was scored by the best student in Chemistry.
- (v) Evelyn was about to fail Mathematics.
- (vi) Bonny was the best student in Physics but he scored 15 more marks in Biology than Mathematics.
- (vii) Students who failed Chemistry scored almost equal marks in Biology.
- (viii) Cissy's marks in Mathematics exceeded Evelyn's marks in Chemistry by 2.

Questions:

- (a) Draw a table indicating each student's score in the four science subjects. (16 marks)
- (b) Identify;
 - (i) a student who scored 52% in Biology. (01 mark)
 - (ii) the best student in Chemistry. (01 mark)

Turn Over

- (c) Account for the increased poor performance of students in the science subjects in government schools. (12 marks)
- (d) What measures should be done by the government of your country to improve on students' performance in the science subjects. (10 marks)
12. Read the passage below carefully and answer the questions that follow. (50 marks)

One of the remarkable facts in the terrible history of famine is that no substantial famine has ever occurred in a country with a democratic form of government and relatively free press. They have occurred in ancient kingdoms and in contemporary authoritarian societies and in modern technocratic dictatorships, in colonial economies governed by imperialists from the north and in newly independent countries of the south run by despotic national leaders or by intolerant single parties.

The act of repression not only assails our human dignity and sensibilities but also exact a toll in terms of human lives and economic activity. Despotism wreaks such economic, social and human devastation that is impossible to measure. Consider the impact on economic activity for example. Generally, countries laboring under deposition perform less well economically. A government run by a depot cannot make decisions which millions of people must make. If two heads are better than one, then certainly a million heads are better than two.

To be sure, impressive rates of economic growth are possible under authoritarian or despotic regimes. China and the Asian Tigers are often cited as examples, but there is a caveat. Exceptions do not make the rule; a final day of reconciling eventually arrives. In an interview, Korea's former President and Late Kim Dae Jung, hit the nail right on the head.

"Many of the leaders of Asian society have been saying that military dictatorship was the way and democracy was not good for their nations. They concentrated only on economic development and building a government around a strong leader who controls economic policy. I believe that the fundamental cause of the financial crisis, including here in Korea, is because of placing economic development ahead of democracyif we had true democracy in Korea, then the collusive intimacy between business and government and corruption would not have been as great here. And the wealth would not have been allocated to only a few people. Usually the dictatorship or authoritarian style of government lies to the people" (The Washington Post, Jan 9, 1998, Page A1)

In a dictatorship, the normal order of things and even common sense have been turned completely upside down. There is no freedom of speech, no rule of law and state institutions are packed with sycophants and praise – singers. Professionalism disappears from the security forces and the civil service. Fealty to the despot counts more than competence or efficiency. Promotions and job security depend upon who can shout the loudest praise to the despot.

Infrastructure, such as roads, bridges, schools, telecommunications and ports, begin to crumble because contracts are awarded by the despot to family members, cronies and loyal supporters. To sustain the heavy patronage doled out to supporters, the despot may impose heavy taxation and tariffs. Prices - especially food and fuel prices - start to shoot up. The public might vent its outrage in street protests. The despot may brutally clamp down on these street protests and take drastic measures to prevent future price hikes. The hikes are blamed on foreign saboteurs. Property rights are scoffed at commercial properties of businessmen alleged to be “anti - government” may be confiscated or seized for distribution to the poor masses in the name of social justice. Such was the case in many countries where for more than a decade despotic regimes organized ruthless thugs to violently seize white commercial farmlands. To be sure, inequitable distribution of land may be a legitimate issue in some African countries, where whites, who comprise about 10 per cent of the population, own about 90 per cent of the best farmland. But the issue is not resolved through barbaric and violent invasion of commercial farmlands.

The economic casts of Africa’s senseless wars and conflicts are incalculable. First and foremost is the wanton destruction they wreak. Infrastructure is reduced to rubble. Roads, bridges, communication equipment are bombed by combatants, houses and building destroyed.

Second, the conflicts uproot people, forcing them to flee the general atmosphere of insecurity and war. Most of the refugees are women, and children but women constitute about 80 percent of Africa’s peasant farmers. Refugees fleeing conflict do not produce food crops. Since 1970 agricultural output has been growing at less than 1.5 per cent - less than the rate of population growth. Consequently, food production per capita declined by 7 percent in the 1960s, by 15 percent in the 1970s, and by 8 percent in the 1980s. Over the postcolonial period 1961 to 1995, “Per Capita food production in Africa dropped by 12 percent, whereas it advanced by leaps and bounds in developing countries in Asia” (The Economist, 7 September 1996; P. 45). Thus, conflicts have a direct impact on Africa’s agricultural production and partly explain why Africa, with all its rich natural endowments, cannot feed itself and imports 30 percent of its food needs. Back in the 1960s, Africa not only fed itself but exported food as well.

Third, conflicts create an “environment” inimical to development and deter investment. Up until 2000, Africa was not an attractive place to invest. Between 1990 and 1995 the net yearly flow of foreign direct investment into developing countries quadrupled to over \$ 90 billion; Africa’s share of this fell to only 2.4 percent. According to the World Bank, in 1995 a record \$ 231 billion in foreign investment flowed into the Third World. Singapore by itself attracted \$ 5.8 billion, while Africa’s share was a paltry 1 percent or \$ 2 billion - less than the sum invested in Chile alone (The Economist, 9 November 1996, 95). According to Algerian President Abdul-Aziz Bouteflika, Algeria’s civil war that started in 1991 has killed 100,000 and caused \$ 20 billion in economic losses” (The Washington Times, July 14, 2001; P. A5)

The crisis in Zimbabwe, for example, has cost Africa dearly. Foreign investors have fled the region and the South African rand has lost 25 percent of its value since 2000. According to The Observer (London) (September 30, 2001) Zimbabwe's economic collapse had caused \$ 37 billion worth of damage to South Africa and other neighbouring countries. South Africa has been worst affected, while Botswana, Malawi, Mozambique, and Zambia have also suffered severely

(slightly adopted from "The Devastation" By Prof. George Ayittey.

Published: June 6, 2012)

Questions:

- (e) What is the central argument of the writer? (02 marks)
- (f) (i) Give the perceived advantages of despotic leadership. (03 marks)
- (ii) What is meant by, "fealty to the despot counts more than competence or efficiency"? (03 marks)
- (g) In about 100 words, summarise the effects of despotism on African nations. (12 marks)
- (h) Briefly explain the meanings of the following words and expressions as used in the passage. (20 marks)
- i) intolerant single parties.
 - ii) exacts a toll.
 - iii) collusive intimacy.
 - iv) sycophants.
 - v) patronage doled out.
 - vi) vent its outrage.
 - vii) saboteurs.
 - viii) leaps and bounds.
 - ix) natural endowments.
 - x) inimical to development.

END

ACTIVITY 14

S101/1 GENERAL PAPER

Instructions to candidates:

- (i) Answer two questions which must be chosen as follows: one question from section A and one question from section B
- (ii) You are advised to divide your time equally between the two questions
- (iii) All questions carry equal marks

SECTION A:

Answer one question from this section. Answers should be between 500 and 800 words in length

1. To what extent is Africa's economic stagnation a result of bad leadership? (50 marks)

2. Discuss the respects and ways in which religion has become an opium to the people. (50 marks)
3. What are the causes and effects of female Genital Mutilation (F.G.M) in some selected parts of Africa? (50 marks)
4. Present an essay about the loopholes associated with Bride – price as a cultural practice. (50 marks)

SECTION B:

Answer one question from this section.

5. Study the information below and answer the questions that follow.
The police crime report for the last five years shows the crime rate is still high. In 2009, police handled 103,592 crimes, 99,917 crimes were handled in 2010, 99321 crimes were committed in 2011, 100,465 crimes were handled in 2012 and 99,959 in 2013.
Source: daily Monitor 8th April 2014

Questions:

- (a) (i) Draw a bar graph to represent the above information. (6 marks)
- (ii) Calculate the percentage increase or decrease of the crimes committed every year. (8 marks)

The police annual crime report for the year 2013 shows that murder cases increased from 8,076 in 2012 to 9598 in 2013, defilement cases increased from 8,076 in 2012 to 9,598 in 2013. Domestic violence cases increased from 2,793 to 3,426. The report also shows rape cases increased from 530 in 2012 to 1,042 in 2013 and 641 people died in traffic accidents in 2013 as compared to 224 in 2012.

Most defilement cases were reported in the districts of Iganga, Mbale and Kamuli (all in Eastern Uganda) while Kampala registered higher cases of domestic violence.

- (b) Calculate the percentage increase of the various crimes in 2013. (10 marks)
- (c) Account for the increased crime rate in Uganda. (6 marks)
- (d) (i) In your view, why is the defilement rate high in Eastern Uganda as opposed to other parts of Uganda? (6 marks)
- (ii) Why is domestic violence high in Kampala? (4 marks)

6. Read the passage below and answer the questions using your own words whenever possible.

Most parents think that the child is too young to understand that they are quarrelling as he is too young to comprehend the reason for the discord. What most parents are not aware of is that, innocent children are definitely aware of the fighting between the parents and quite often believe that parents are fighting because of them.

Each child is a unique human being with a complex set of emotions and sensibilities. Each child's reaction is individualistic too. There is no set or definite Pattern as to how a child will react to the warring parents. Undoubtedly, whatever the reaction might be, the child would be hurt by the disagreement between the parents.

Some children might just withdraw and become total introverts, others might show maturity much beyond their years. There might be a third reaction altogether, making some children revolt and become unmanageable. They end up being rude and cruel to other children around them, turning into bullies. They do not follow any set rules of society. Research done in the field of child Psychology has proved that the children who see the violation interaction between their parents seem to be surrounded by troubles all their lives. They are through all their growing years constantly living with the fear that if their parents separated, from their siblings, or have only one parent around them.

Similarly, in cases when a divorce takes place and where one parent gets remarried, the child believes that the union might break as well. He does not let himself get too close to the step parent in such cases. It is true that the fighting between the spouses is essentially a physical, mental and emotional torture for the child. It might physically affect the health and growth of the child as well. Even a normal child could start stammering, or his development might be hampered.

In their innocence, the children might spill the details of the parents' constant fighting among the relatives and friends, thereby creating embarrassment for the parents. If they feel they are not getting due care and affection from both of their parents, they might turn to strangers for it. They often become vulnerable to the negative sections of society who might abuse their trust. Imagine a situation where a child says to a stranger or a relative, "you love me so much but my own mother does not love me at all"

When parents fight constantly, the child feels a physical, mental, emotional and social separation and therefore suffers. His understanding of "Marriage" gets distorted and when this child reaches adulthood, the fear of marriage sets deep in his Psyche. Marriage to him becomes not a balanced equation of love and trust, but something that would bring fights and discord in their lives. It is every parent's moral duty to take full responsibility for the child's physical and mental development.

Questions

- (a) Suggest an appropriate title for the passage. (2 marks)
- (b) What major misconceptions do parents have about children? (6 marks)
- (c) In not more than 100 words, give a summary of the effects of fighting between parents on the children. (12 marks)
- (d) Explain the meanings of the following words and phrases as used in the passage using your own words wherever possible.
 - (i) Individualistic
 - (ii) Definite pattern
 - (iii) Introverts
 - (iv) Essentially
 - (v) Spill
 - (vi) Negative sections
 - (vii) Psyche
 - (viii) Balanced equation
 - (ix) Discord in their lives
 - (x) Moral duty.

(20 marks)

(SPGE 10 marks)

ACTIVITY 15

GENERAL PAPER

INSTRUCTIONS:

- *Answer two questions which must be chosen as follows;
One question from section A and one question from section B.*
- *Answers to each question must begin on a fresh answer sheet or page.*
- *You are advised to divide your time equally between the two questions.*

SECTION A:

Attempt one question from this section.

Answers should be between 500 and 800 words in length.

1. With illustrations, examine the causes and effects of the refugee problems in Uganda.
2. To what extent has the Mass media influenced the morals among the youth in Uganda.
3. Discuss the reasons why unemployment is a menace to Uganda.
4. "Dialogue other than militarism is the best way to resolve political conflicts." Discuss.

SECTION B:

Attempt one question from this section.

5. Study the information provided in (i) and (ii) carefully and then answer the questions which follow.

(i) A grocer will offer a particular kind of fruit for sale only on the day it is delivered.

The delivery schedule is the same each week.

The grocer's store is open for business Monday through Saturday only.

Bananas are delivered only every other business day.

Oranges are delivered every business day.

Passion fruits are delivered on two non-consecutive business days, but not on Monday, Friday or Saturday.

Lemons are delivered on the same days as bananas also on Saturdays.

Pineapples are delivered only on the two consecutive days on which lemons are delivered.

Answer the following questions, showing how you arrive at your answers in each case.

- (a). what is the minimum number of days on which both lemons and passion fruits are purchase?
- (b). on which days are the fewest kinds of fruits mentioned above, for sale?
- (c). if each delivery of bananas during a week were delayed one day, but all other deliveries are made according to schedule, on what days would bananas, oranges and passion fruits be purchased on the same day?
- (d). On days when lemons and oranges are delivered, which fruit(s) is (are) also delivered?
- (ii). What are the best ways in which fruit farming in Uganda can be modernized?

6. Read carefully the following passage and answer the questions that follow, using your own words wherever possible.

In the matter of girls, I was different from most boys of my age. I admired girls a lot, but they terrified me. I did not feel that I possessed the peculiar gift or accomplishments that girls like in their male companions—the ability to dance, to play football, to cut up a bit in public, to smoke, and to make small talks. I couldn't do any of these things successfully and seldom tried. Instead I stuck with the accomplishments I was sure of: I rode my bicycle sitting backwards on the handlebars, I made up poems, I played selections from "Aida" on the piano. In winter I tended goal in the hockey games on the frozen ponds in the Dell. None of these tricks counted much with the girls. In the four years I was in the Mount Vernon High School, I never went to a school dance and I never took a girl to a drugstore for a soda or to the Westchester Playhouse or to Proctor's. I wanted to do these things but did not have the nerve. What I finally did manage to do, however, and what is the subject of this memoir, was far brassier, far gaudier. As an exhibit of teen-age courage and ineptitude, it never fails to amaze me in retrospect. I am not even sure it wasn't un-American.

My bashfulness and backwardness annoyed my older sister very much, and at about the period of which I am writing she began making strong efforts to stir me up. She was convinced that I was in a rut, socially, and she found me a drag in her own social life, which was brisk. She kept trying to throw me with girls, but I always bounced. And whenever she saw a chance she would start the phonograph and grab me, and we would go charging around the parlour in the toils of one-step, she gripping me as in a death struggle, and I

hurling her finally away from me through greater strength. I was a skinny kid but my muscles were hard, and it would have taken an unusually powerful woman to have held me long in the attitude of the dance.

One day, through a set of circumstances I have forgotten, my sister managed to work me into an afternoon engagement she had with some others in New York. To me, at that time, New York was a wonderland largely unexplored. I had been to the Hippodrome a couple of times with my father, and to the Hudson-Fulton celebration, and to a few matinees; but New York, except as a setting for extravaganzas, was unknown. My sister had heard tales of tea-dancing at the Plaza Hotel. She and a girlfriend of hers and another fellow and myself went there to give it a try. The expedition struck me as a slick piece of arrangement on her part. I was the junior member of the group and had been roped in, I imagine, to give symmetry to the occasion. Or perhaps mother had forbidden my sister to go at all unless another member of the family was along. Whether I was there for symmetry or for decency I can't remember, but I was there.

The spectacle was a revelation to me. However repulsive the idea of dancing was, I was filled with amazement at the set-up. Here were tables where a fellow could sit so close to the dance floor that he was practically on it. And you could order cinnamon toast and from the safety of your chair observe girls and men in close embrace, swinging along, the music playing while you ate the toast, while the dancers so near to you that they almost brushed the things off your table as they jogged by. I was impressed. Dancing or no dancing, this was certainly high life, and I knew I was a scene miles and miles ahead of anything that took place in Mount Vernon. I had never seen anything like it, and ferment must have begun working in me that afternoon.

Incredible as it seems to me now, I formed the idea of asking Parnell's Sister Eileen to accompany me to a tea-dance at the Plaza. The plan shaped up in my mind as an expedition of unparalleled worldliness calculated to stun even the most blasé girl. The fact that I did not know how to dance must have been a powerful deterrent, but not powerful enough to stop me. As I look back to the affairs, it's hard to credit my memory, as I sometimes wonder, if in fact, the whole business isn't some dream that has gradually gained the status of actuality. A boy with any sense, wishing to become better acquainted with a girl who was of "special interest", would have cut out for himself a more modest assignment to start with—a soda date or a movie date—something within reasonable limits. Not me. I apparently became obsessed with the notion of taking Eileen to the Plaza and not to any damned old drugstore. I had learned the location of the Plaza, and just knowing how to get to it gave me a feeling of confidence. I had learned about cinnamon toast, so I felt able to cope with the waiter when

he came along. And I banked heavily on the general splendor of the surroundings and the extreme sophistication of the function to carry the day, I guess.

Question:

- (a) Suggest a suitable title for the passage.
- (b) What, according to the passage, were the expected qualities in male companions?
- (c) In not more than 100 words, show how the writer is socially transformed.
- (d) Explain the meaning of the following words and phrases as used in the passage, using your own words wherever possible:
 - (i) Small talk
 - (ii) Tended goals
 - (iii) Have the nerve
 - (iv) Stir me up
 - (v) Afternoon engagement
 - (vi) Roped in
 - (vii) For decency
 - (viii) Powerful deterrent
 - (ix) Gained the status of actuality
 - (x) Extreme sophistication.

ACTIVITY 16

GENERAL PAPER

INSTRUCTIONS TO CANDIDATES:

The total time of 2 hours and 40 minutes includes ten minutes for you to study the questions before you begin answering.

*Answer **two** questions which must be chosen as follows: one question from section **A** and **one** question from section **B**.*

Answers to each question must begin in a fresh answer booklet which should then be fastened together.

You are advised to divide your time equally between the two questions.

All questions carry equal marks

*Any additional question(s) attempted will **not** be marked.*

SECTION A

*Answer **one** question from this section.*

Answers should be between 500 and 800 words in length.

1. To what extent is the Education system responsible for the current high rate of unemployment in Uganda? (50 marks)

4. "Poverty is the primary cause of underdevelopment in Uganda." discuss. (50 marks)

3. Account for the rampant cases of cohabitation and suggest measures to curb the trend. (50 marks)
 4. "The AMISOM intervention in Somalia is a clear indicator that African states can independently solve their political problems." Discuss. (50 marks)

SECTION B

5. **Carefully study the information given below and answer the questions that follow.**

In Blaster Academy, all round excellence is a virtue. Given their educational programmes, many a company, or institution eagerly awaits the release of the final year results. This stems from the fact that top performers are always enlisted on various scholarship programmes by architectural, graphic, investment and social based organizations.

To grade the students, the Educational Programmes Directorate that runs the school follows these guidelines:

1- There are only four grades in the academy; G, D, M and O.

2- The letters denote an assessment of a candidate's performance; thus, G-Genius, D-Distinguished, M-Magnificent, O-Ordinary.

3- Each of the grades has a mark range as follows; Excellent-90+, Good-80+, Commendable-70+, Tried-55+, Repeat-0+. Aggregate scores for the mark ranges in descending format are; 5, 4, 3, 2 and 1 respectively.

4- A candidate is assessed on the basis of average aggregate scores [A.A.S], so, an AAS of 1-1.5 earns one grade G, 1.6-2.4 grade D, 2.5-3.4 grade M, and 3.5+ grade O.

5- The subjects up for contest are; Economics, Computer and Mathematics.

6- Of the final mark, class assignments [C.A] and tests [T] constitute 15 and 30 percent respectively.

7- The pass mark for each paper is 70% besides which, a lower mark automatically earns one an Ordinary grade. The scores of each candidate were as below;

	ECONOMICS				COMPUTER				MATHS	
	I	II	C.A	T	I	II	C.A	T	I	II
Atim Georgine	70	100	98	53	95	100	79	100	93	83
Ddamba Darius	90	58	96	99	97	69	94	100	87	100
BembaWycliffe	98	60	100	95	89	92	75	99	100	74
Zaria Leila	100	95	79	97	99	83	85	78	76	100

Nakalema	94	81	98	100	88	79	87	96	100	75
Drusilla										

- All tests done were for paper II of each subject, while C.As were for paper I.
- Paper I in economics covers business skills such as accounting and finance, while the CA deals with community development projects.
- Paper II deals with environmental impact assessment, creativity, labour, industrial and agricultural issues.
- Paper I-computer covers office skills such as MS Office while paper II deals with computer based graphics and audio software packages like Cinema 4D and Logic Platinum.

[a] Calculate the final score of each candidate (20 marks)

[b] The grading is based on points thus: G-16, D-15, M-13 and O-10. Which student was the;

(i) best

(ii) worst? (02 marks)

[c] In which papers were students expected to fare better and why? (04 marks)

[d] Each student only qualifies for one course. Allocate students to the following courses;

(i) Architecture

(ii) Film Editing

(iii) Community Development

(iv) Investment Authority. (08 marks)

[e] What are the merits and demerits of the Blaster Academy grading system?

Spelling, grammar and expression

– (10 marks). (50 marks)

6. Read the following passage and answer the questions that follow

It would be naïve to think that possessing a doctorate in psychology or a degree in medicine is a guarantee that a professional is capable of treating every client requesting services. Mental health professionals are guided by standards that specify that they possess the skills needed to treat people who approach them for professional services. In other words, they should have the intellectual competence to assess, conceptualize, and treat clients whom they accept into

treatment. Furthermore, they need to be emotionally capable of managing the clinical issues that emerge in treatment.

Consider how inappropriate it would be for a clinician without any training or experience in the treatment of people with severe eating disorders to advertise that he is opening a specialty practice in treating women with anorexia nervosa. Obviously, he would be practicing in a field in which he lacks the competence to treat people with specialized treatment needs, and his behavior would be unethical. In a case such as this, the **absurdity** is evident. However, there are other cases in which the clinician may have the training and experience, but not the **emotional competence**, to deal with certain kinds of clinical issues. Mental health professionals are expected to conduct regular self-scrutiny, in which they make an effort to objectively evaluate their competence to carry out their work. When faced with prospective clients whose needs are beyond the clinician's competence, a referral should be made or the clinician should obtain appropriate supervision. Self-assessment of emotional competence is a bit more difficult, in that it can be difficult to recognize the depth or extent of one's own problems. Astute clinicians regularly seek out the advice of senior or peer consultants to help them make such evaluations. Competency is a **multifaceted phenomenon** that includes a clinician's sensitivity to people of diverse backgrounds and the clinician's effort to understand and acquire knowledge about individuals from differing backgrounds.

Assuming that the clinician has the intellectual and emotional competence to treat, the next set of issues pertains to obligations within the treatment context. Although it would be **unusual to have a legalistic contract for therapy**, experts in the field recommend some form of therapeutic understanding. In other words, clinicians should provide clients with the information they will need to make decisions about therapy. There are several key elements in the sound therapeutic contract. At the outset of therapy, clinicians should discuss goals of treatment, the process of therapy, the client's rights, the therapist's responsibilities, the treatment risks, the techniques that will be used, financial issues, and the **limits of confidentiality**. When these matters have been discussed, the client gives informed consent, an indication that he or she has participated in setting the treatment goals, understands and agrees to the treatment plan, and knows the clinician's credentials. Generally, clients are given a written statement containing this information. In cases in which a risk is involved in treatment, such as when medication or electroconvulsive therapy is recommended, the client should understand the possible short-term and long-term side effects. The clinician has a responsibility to ensure that the client is made aware of these issues, is given answers to these questions, and is given the opportunity to refuse treatment.

This process has some complications. Psychotherapy is an **imprecise procedure**. The clinician's job, however, is to give a best estimate at the onset of therapy and to provide further information as therapy proceeds. Most people are able to discuss these matters with the clinician and to make an informed choice. However, what happens when prospective clients are unable to understanding the issues in order to make informed consent? This is the case with people who are out of touch with reality, people who are mentally retarded, and children.

In these cases, the clinician must work with the individual's family or other legally appointed guardians. The clinician must make every effort to ensure that client's rights are protected.

Part of the informed consent process involves informing the client that what takes place in therapy is private. Confidentiality, long regarded as a sacred part of the clinician-client relationship, refers to the principle that the therapist must safeguard disclosures in therapy as private. Why is confidentiality so important? In order for clients to feel comfortable disclosing **intimate details**, they need to have the assurance that the clinician will protect this information. In fact, safeguards against the disclosure of confidential information exist within the laws of most states.

The content of therapy is legally considered **privileged communication**. In the context of the courts, privileged communication differs from the general notion that the public is entitled to relevant evidence pertaining to a case. However, there are certain kinds of cases in which the court is entitled to information shared within the therapy context. For example, in certain kinds of child custody cases, a judge may deem that therapy information is crucial in order to protect the welfare of the child. Other exceptions to privilege involve cases in which a defendant is using mental disability as a defense in a criminal trial; in this kind of case, the court would likely rule that the defendant **has waived the psychologist-client privilege as it relates to the defendant's mental state at the time of the alleged crime**. Along similar lines, an exception to privilege applies in a case in which a psychologist is appointed by a court to determine whether the defendant is competent to stand trial; obviously, the psychologist would be expected to share findings from such an evaluation with the court. However, the psychologist would not necessarily have blanket permission to share all that was communicated during the evaluation; the psychologist cannot disclose any statements by the defendant regarding the offence, unless the individual gives **explicit permission**.

As you can see, the work of a mental health professional involves many challenges in cases in which there is a legal aspect. For the most part, the legal system is committed to protecting the **sanctity** of private communication between a mental health professional and a client who has turned to that professional for help. In some instances, however, the client's rights must be overlooked for the good of society and the welfare of other people, such as children, who might be at a risk of harm.

There are some important exceptions to the principle of confidentiality, such as cases involving abuse. Every state requires some form of **mandated reporting** by professionals when they learn first-hand of cases involving child abuse or neglect. Abuse, which may be physical or sexual, is defined as an act by a caretaker that causes serious physical or emotional injury. Neglect is characterized as the intentional withholding of food, clothing, shelter, or medical care. In recent years, many states have expanded mandated reporting statutes to include a wider range of vulnerable people, such as those who are handicapped or developmentally disabled as well as impaired elders who cannot otherwise protect themselves. One variation of mandated reporting that has been enacted in some states is the requirement to report self-

neglect of older persons (60 or older) who are not attending to essential needs for food, clothing, safe and secure shelter, personal care, and medical needs.

Clinicians as well as teachers and other health professionals are required by law to notify the appropriate authorities about cases in which vulnerable individuals are being abused or neglected. The purpose of mandated reporting is to protect victims from continuing abuse and neglect, to initiate steps towards clinical intervention with the abused individual, and to deter, punish, and rehabilitate abusers.

Another exception to the principle of confidentiality involves instances in which the clinician learns that a client is planning to hurt another person. In such cases, the clinician has a duty to warn (sometimes referred to as "duty to protect"). This means that the clinician is required to inform the intended victim that the client plans to harm him or her.

(Slightly adapted from: Abnormal Psychology, Clinical Perspective on Psychological Disorders.)

Questions:

- (a) Suggest a suitable title for the above passage. (02 marks)
 - (b) What does the author mean by:
 - (i) "...unusual to have a legalistic contract for therapy..." (04 marks)
 - (ii) "...has waived the psychologist-client privilege as it relates to the defendant's mental state at the time of the alleged crime..." (04 marks)
 - (c) In about 100 words, validate the call for concessions to privacy. (10 marks)
 - (d) Explain the meaning of the following words and phrases in the passage, using your own words as much as possible:
 - (I) absurdity (02 marks)
 - (ii) Emotional competence (02 marks)
 - (iii) multifaceted phenomenon (02 marks)
 - (iv) limits of confidentiality (02 marks)
 - (v) imprecise procedure (02 marks)
 - (vi) intimate details (02 marks)
 - (vii) privileged communication (02 marks)
 - (viii) explicit permission (02 marks)
 - (ix) sanctity (02 marks)
 - (x) mandated reporting (02 marks)
- Spelling, grammar and expression – (10 marks).

(50 marks)

End

Merged by; Musamali Joel MUSESE SS
2023/10/19

